

KINZE

ROW CROP

PLANTERS

SUPERIOR ACCURACY AND EFFICIENCY



KINZE
EUROPE

THE STORY OF KINZE



Everyone knew young Jon Kinzenbaw had a gift. But no one could have predicted his business would grow into one of the largest, agricultural equipment manufacturers in North America.

Back in 1965, a 21-year old farm boy from Victor, Iowa with an ability to “fix things” opened his own welding shop, with a small bank loan and \$25 in his pocket.



Jon Kinzenbaw, Founder and CEO of Kinze Manufacturing Inc.

- 1965**
Jon Kinzenbaw opens Kinze Welding in Ladora, IA
- 1969**
Anhydrous applicator is first mass-produced product
- 1971**
First two-wheeled grain cart
- 1975**
Patented rearward folding planter
- 1983**
Split-row system with push row units
- 1985**
Patented lift and rotate folding planter
- 1999**
Evolution Series row unit and 3000 series planters introduced

The Overnight Revolution

The event that really changed Kinze, and farming, was a conversation Jon had with farmers in 1975. After hearing some of his friends complain about the amount of time they wasted constantly dismantling and loading their planters onto drop-bed trailers, Jon invented a rear-folding planter toolbar.

And planting changed forever.



- 2010**
New corporate headquarters in Williamsburg, IA
- 2013**
4900 planter with electric drive meters
- 2013**
Kinze opens a manufacturing facility in Lithuania
- 2014**
First 100th planter were delivered to European customers
- 2018**
First Blue Vantage monitor was built
- 2020**
Kinze True Speed meters introduced
- 2027+**
More innovations to come...

TODAY'S KINZE

Kinze is still privately held by the Kinzenbaw family. The company's world headquarters and manufacturing facilities span more than 30 acres under one roof. As a market leader in innovating, durable and high-quality planters and grain carts, Kinze continues to reinvest into the future with state-of-the-art facilities and manufacturing equipment.

In 2013, Kinze opened its first production plant abroad in Lithuania. The new facility manufactures Kinze row crop planters for the European markets. Opening the Lithuanian facility not only allowed Kinze to provide better and faster service to our European customers, but it also freed up production capacity in the Williamsburg Iowa plant.



Kinze Manufacturing Inc., Williamsburg, IA, USA



Kinze Europe, UAB, Vilnius, Lithuania

KINZE ACCURACY BOOSTS PROFITS FOR ALL YOUR CROPS

Seed depth, singulation, seed spacing, and seed-to-soil contact, are the four planter functions that affect crop performance, yields, and ultimately, revenue.

REALITY OF SKIPPED SEEDS

You only have one chance to put seed properly in the ground. Seed singulation, spacing, depth, and soil contact must all be done correctly to maximize germination, plant growth, yield, and profit (see page 4 for additional information).*

*Pioneer study, "Planting Outcome Effects on Corn Yield"

THE SPLIT ROW ADVANTAGE

Are you planting soybeans, rapeseed, or other narrow-row crops? With a single Kinze planter you can quickly and easily convert from wide to narrow rows and benefit from the increased accuracy and precise depth control that a Kinze planter provides.

CORN



Do you want an additional 70 000 € in revenue per 1 000 hectares in corn? Because corn yield is reduced 77 kg for every 1% in skips, you can tremendously increase your profit by switching to a faster and more accurate Kinze planter and improve singulation by 4.5%.

See how Kinze planter accuracy can potentially increase your revenue.
www.Kinze-Europe.com/resources/profit-calculator

SUNFLOWERS



Planting sunflowers? There is no need for different meters — simply change the meter seed disc and start planting. Improvement in singulation of 4% to 6% is typical when using the Kinze True Rate vacuum meter.

RAPSEED AND SOYBEANS



Reduce input costs and increase yield by planting with a precision split row planter. With improved accuracy and precise depth control germination is improved and yields are maximized.



Actual field results show that by planting rapeseed using Kinze split row technology, and using 35% LESS seed, rapeseed yields have improved 0.5 tonnes per hectare. This calculates out as an increase of 185 € profit per hectare, or 185 000 € per 1 000 hectares!

THE KEYS TO MORE PROFIT

Seed depth, singulation, seed spacing, and seed-to-soil contact, are the four planter functions that affect crop performance, yields, and ultimately, revenue.

SEED DEPTH

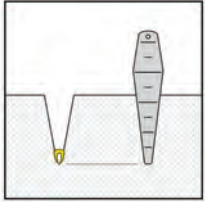

Correct and consistent seed depth is very important for proper seed germination and healthy root development. A kernel of corn, for instance, absorbs about 30% of its weight in water to properly germinate, and requires a proper planting depth for consistent moisture. Nodal roots must be established at the proper depth to reduce early season root lodging and improve drought tolerance.

SEED SPACING

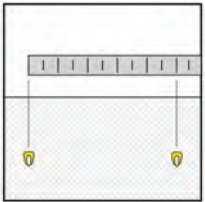

Greatest yields are realized when seeds are equally spaced and not competing for sunlight, moisture, and nutrients. While a seed meter may have a high rate of singulation, that does not ensure seeds are being equally spaced in the row. The measurement of how well a meter is releasing seed, and the variation of seed spacing that results, is called the Coefficient of Variation (COV).



Good COV



Poor COV

SINGULATION

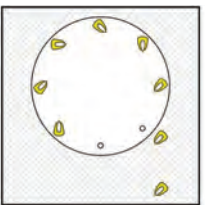

Singulation is the isolation of a single seed so it can be dropped into a seed trench without skips or doubles. When seeds are skipped, there are spaces where no seed is planted, and for every 1% drop in singulation, there will be a yield loss of 77.25 kg* per hectare. Doubles are created when two seeds are planted where there should only be one, which compromises the plant's performance due to sharing of sunlight, moisture, and nutrients.

*Pioneer population study, 2016

SEED-TO-SOIL CONTACT

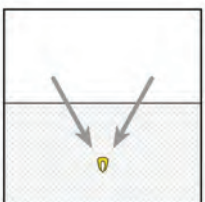

Many factors affect seed-to-soil contact including: soil conditions, planter hitch height, closing wheel alignment, closing wheel pressure, and closing wheel design. Making sure the planter is properly adjusted and the proper closing wheels are selected for the soil type are critical for good seed-to-soil contact for maximum and uniform emergence.

RESULTS FROM OUR CUSTOMERS

SPLITROW AND MULTI-CROP PLANTING ADVANTAGES

“We have used a Kinze planter since last year to plant both sunflowers and corn. Last year we were incredibly pleased with this planter because it puts the seed exactly where it needs to be, at the right depth and the right spacing. Leading to uniform emergence. On our farm we use a Kinze 3605 with 31 rows on 35 cm row spacing and 16 rows on 70 cm row spacing. We can work both at 35 cm and 70 cm by raising or lowering the front row units. Our reasons for choosing Kinze are that we can use the latest technology and sow directly, without prior soil preparation (no-till) and switch to liquid fertilizers. It is also quite versatile; it can sow many different types of crops, thus covering all the crop types we need.”

~ Amalia Pascu (Romania)

REPEAT CUSTOMER

“From 2011 we switched to no-till farming. We were using Kinze planter from a neighboring cooperative and because we'd gotten a lot of experience from it with the crops and establishing growth, we bought our Kinze planter in 2013, an eight-row Kinze 3500 twin row. I can't imagine us changing the technology, like we'll always be using the Kinze; this mechanism is so excellent for planting. It works so well, we've been very satisfied with it.”

~ Robert Dohál (Slovakia)

SIGNIFICANT IMPROVEMENTS OF THE FARMING PRACTICES

“When considering our options in the market, we found that Kinze planters perfectly met all our needs. The planter's ability to meet the necessary parameters played a pivotal role in our decision to invest in Kinze. After extensive market research, no other models matched Kinze's ability to fulfill their specific needs. The comprehensive capabilities and exceptional quality of Kinze products made it the ideal choice for us. With a focus on precision and efficiency, the Kinze planter consistently achieved high-quality results across multiple crops, including rapeseed, wheat, barley, sunflower, and corn.”

~ Ion Moroi (Moldova)

ACCURATE AND SIMPLE TO OPERATE

“We looked for a planter that meets the following requirements: accuracy of planting, precise delivery of set seed rate, and the planter had to be simple to transport, operate, and maintain.

We planned to plant more than three thousand hectares of sunflower and corn this year. The planter did the job well. We will definitely recommend this planter to other farms because it ensures all that is needed for high-quality planting and easy operation.”

~ Andriy Pasos, Agricultural Firm Luga-Nova (Ukraine)

HIGH YIELDS WITH NO-TILL TECHNOLOGY

“We have a Kinze 12R planter and utilize the no-till technology, which saves a lot of fuel, time and labor costs. Our soils are weak, and in order to be profitable we cannot produce at high costs. With the Kinze planter, we planted 1 500 hectares of rapeseed, sunflower and corn and we are very happy with the yields.”

~ Vesko Pishchiiski, Tanyo Enchev Agricultural Cooperative (Bulgaria)

PLANTER DISPLAY UNIT

BLUE VANTAGE

Simple. Accurate. Intuitive.

Blue Vantage® is the industry's easiest-to-use dedicated planter display. Designed by Kinze and exclusive to Kinze planters, this innovative, clean, and streamlined display provides simple, accurate, and intuitive planter control for high-productivity planting. Factory presets remove the labor and guesswork from setup, while a dedicated planting screen provides all critical information at one glance during planting. Built-in diagnostics provide easy and efficient troubleshooting.

- Only 3 clicks are required to start planting with the rugged and simple-to-use touch-screen
- A single screen displays all critical information, and factory presets eliminate setup guesswork
- See clearly behind the planter with up to 4 rear-facing cameras
- Remote viewing of the Blue Vantage screen when logged into a Blue Connect account
- Adjust prescription map populations after importing them -directly from the plant screen
- Supports planting wheat with True Rate & True Speed vacuum seed meters
- The Blue Connect data solution has no unlock codes and you, the farmer, always own the data

Plant Screen

Shutoffs:
Tap for manual shutoffs and toggle automatic shutoffs

Row-by-Row Graph:
Includes population, singulation, and down force information

Center / Field Zoom:
Toggle between full-field or tractor-centered zoom levels

Hectares & Speed:
Displays hectares planted during current session, current task, current speed, bulk fill scale & Blue Connect information

Data Layer Legend:
Displays legend for planter swath and adjustable bar graph

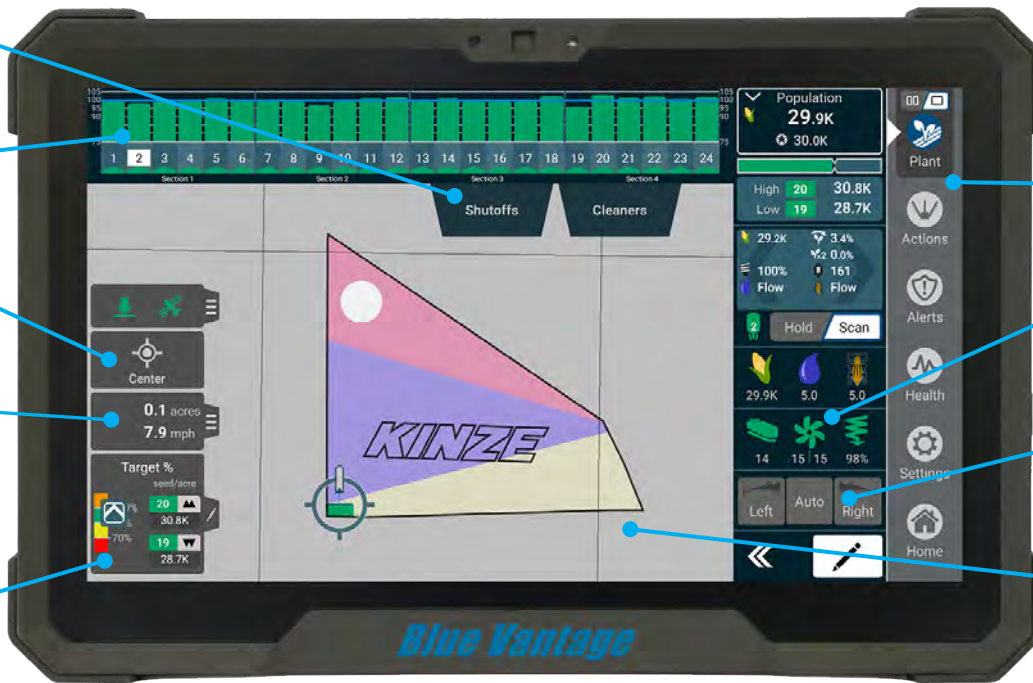

Navigation Bar:
For easy display navigation

Pressures:
Monitor and adjust fan pressure and down force settings

Side Bar:
Customizable side bar displays most used information

Touch Screen:
With pinch zoom control

All plant screen map layers can be viewed in single- or split-screen mode and enable you to monitor two planting maps at the same time. A simple touch of the PLANT icon toggles the screen between modes.

Shared Mapping (Map Sync®)



Split Screens



Blue Drive and Blue Vantage availability

Model	Row Configuration
3505	8 Row 70 cm*
3605	12 Row 70 cm*
3605	16 Row 70 cm*
4805	24 Row 70 cm

* Split row option available

BLUE CONNECT

A remote cloud-based data storage solution for planting and field data.

- Blue Connect and the Blue Vantage display exchange data whenever Blue Vantage has a customer-supplied internet connection and is signed into a free Blue Connect account.
- No unlock codes are required since it is included with the Blue Vantage display - and the farmer always owns the data.
- Enables remote viewing of the display by customers and dealers, and performing wireless software updates. Setting up a Blue Connect account is fast, easy, and completed right from the display.
- The shared mapping feature Map Sync® enables two or more planters equipped with Blue Vantage displays to share planting coverage data in the same field at the same time.
- Enables sharing of logged data with John Deere Operations Center™ and Ag Leader AgFiniti®

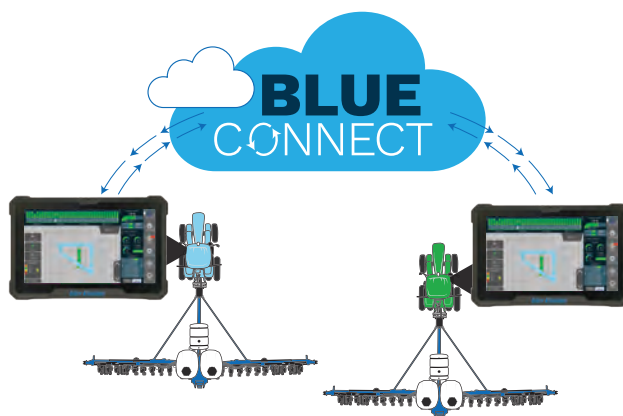

Climate FieldView

Add a **FieldView™ Drive adapter kit** and an iPad, and the Cab App to upload data to your FieldView account. Check for compatibility at support.climate.com.

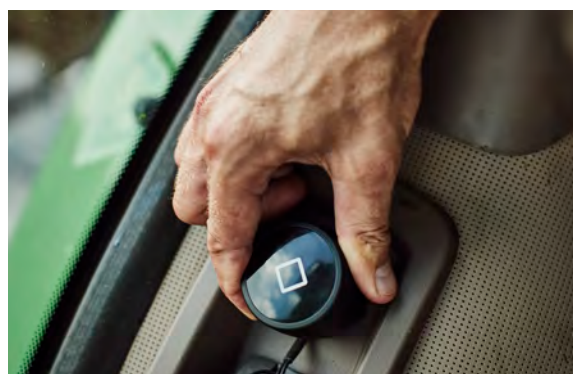

BLUE DRIVE TRUE Confidence.

Blue Drive® is a Kinze designed electric drive system that is simple, reliable and accurate, giving you confidence during the planting season. The industry-exclusive design is used throughout the planter and delivers enhanced section control and accurate seed placement, ensuring maximized profitability.

PATENTED
Ethernet
technology

- **Ethernet connectivity provides reliable, faster connection** and speeds for quick software updates and troubleshooting
- **Designed to be easily updated with software upgrades** and additional features that require no costly unlock codes.
- **Kinze Blue Drive electric drive equipped planters** are covered by an industry leading **2-year hitch pin to closing wheel warranty**

HIGH SPEED PLANTING SOLUTION

TRUE SPEED

Accurately achieve results at TRUE higher speeds.

Accurately plant at speeds from 5-19 km/h with the **True Speed**® high speed meter and plant up to twice the number of hectares in a day versus a conventional meter.* By controlling the seed from the seed disc to placement in the seed trench, precise singulation and seed spacing are achieved regardless of seed size, shape, or coating. Industry leading low seed release point delivers superior spacing accuracy for precise seed positioning in the row.

*Subject to equipment, seed type and field conditions

- Easily replaceable industry leading wear components are long life and low cost — saving time and money
- A single, no-adjust singulator is all that is needed for planting corn, sugar beets, milo, cotton, and oil sunflowers
- Self-aligning delivery tube flighted belt does not stretch, or require removal after the planting season
- All access to the meter and delivery tube are tool-less for easy and efficient crop change-overs and maintenance
- Quick changeover of seed type is aided by a pivoting meter mount with lock-up, and easy to remove seed discs

True Speed high speed meter seed discs



Soybean
92 Cell



Soybean
46 Cell



Corn
32 Cells



Sugar beets/milo
46 Cells



Cotton
46 Cells



Oil Sunflower
23 Cells



Rapeseed/Canola
104 Cells



Wheat/barley
210 Cells

Accuracy at your speed to maximize field efficiency and planting performance at speeds from 5-19 km/h.

	8 km/h	11,3 km/h	16 km/h	19,3 km/h
Hectars/hour (24 row planter)	10,5 ha/h	14,6 ha/h	20,6 ha/h	24,7 ha/h
Hectars/hour (16 row planter)	6,8 ha/h	9,7 ha/h	13,8ha/h	16,6 ha/h
% efficiency increase	-----	29%	50%	60%

True Speed availability¹

Model	Row Configuration
4805	24 row 70 cm
3605	16 row 70 cm ²
3605	12 row 70 cm ²
3505	8 row 70 cm ²

¹available on bulk fill only
²available with split row option





No adjust singulator
One singulator for all crop types requires no adjustment

Unique meter orientation
Perpendicular meter orientation provides seamless seed handoff from disc to delivery tube

Unique seed disc paddle design
Provides positive load-in and holds the seed for precise handoff to delivery belt



Kevlar reinforced belt
Wear components designed for long life and lower cost of ownership. Seed delivery belt has 600+ row hectares of wear life per row and removal is not required at end of season.

Lowest release points in the industry
For superior Coefficient of Variation (COV)



Brush wheel

- Keeps seed in control with a positive handoff from the seed disc to the delivery belt
- Longer life and low cost replacement provides lower cost of ownership

HIGH PERFORMANCE

TRUE RATE VACUUM METER

Accurately plant a variety of seeds at a TRUE metered rate.

The **True Rate**® vacuum meter, with its wide selection of easy-to-change seed discs, can plant at speeds up to 13 Km/h*. The durable and easily serviceable design requires only one singulator for easy operation, optimum performance, and low cost of ownership.

*As field conditions allow

- **Consistent seed drop** from the 3 o'clock position regardless of planter speed or population
- **Singulation accuracy is easy to maintain** using just one easily adjusted singulator
- **Vacuum levels remain constant** with an engineered long-life polymer seal
- **Improved COV, especially on slopes**, from tapered edge seed disc design
- **Quick crop changeover** facilitated by simple removal of meter cover and seed disc

True Rate meter seed discs



Corn & Large Sweet Corn
40 Cells



Soybean
120 Cells



Soybean
60 Cells



Wheat
231 Cells



Edible Beans
(Pinto, Great Northern)
60 Cells



Edible Beans
(Black, Turtle, Navy & Popcorn)
60 Cells



Sugar beet/Milo
60 Cells



Cotton
60 Cells



Sunflower (2,3,4) & Small Sweet Corn
40 Cells



Long lasting seal
Made from thermoplastic silicone

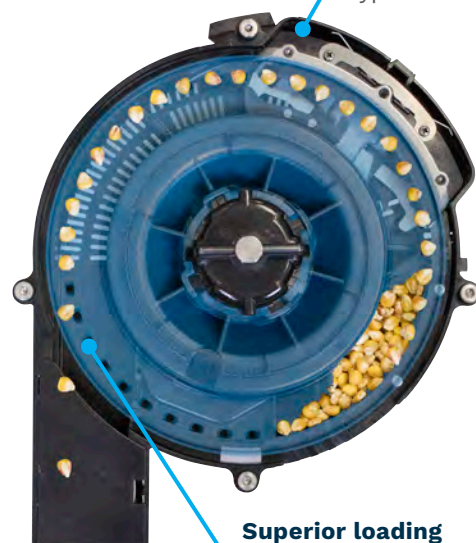

Easy adjust singulation
One adjustable seed singulator for all seed types and sizes

Superior loading

- Seed pool shape promotes 100% clean out
- Seed channel ensures every seed cell is loaded, preventing skips

MECHANICAL METERS

Brush Meter

Seeds are singulated in formed end-pockets and retained by a brush along the housing perimeter

The proven Kinze brush meter provides a low-maintenance and accurate meter solution for high volume crop populations, that is easy to clean, operate and maintain. Changing seed discs require no tools; low maintenance and low cost durable brushes.

Brush meter seed discs

Color-coded seed discs allow you to plant different crops, seed sizes and populations.



Brush meter seed discs

Soybean



60 Cells

48 Cells

Milo/Grain Sorghum



30 Cells

60 Cells (small high-rate)



60 Cells (large high-rate)

30 Cells (large)

Cotton



30 Cells

36 Cells (large)

48 Cells (high-rate)

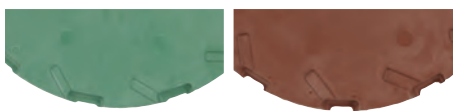

12 Cells (small)

12 Cells (hill drop)

Finger pick-up meter

Mechanical meter solution for mid-range seed size and planting speed of 6.4-9.6 km/h.



Brush and seed bump design improves singulation of the seed

Specially-designed seed release opening in the finger wheel carrier plate prevents bounce back when seed is delivered to the conveyor belt

TRUE DEPTH

HYDRAULIC DOWN FORCE

Automatically hit your TRUE target depth to increase yields.

True Depth® hydraulic down force removes the guesswork from down force settings. It maintains a consistent seed depth for optimum emergence and root development along with minimizing sidewall compaction. During conventional or no-till planting, gauge wheel load is constantly measured, and automatically and instantly adjusts the down force, or up-lift, for individual row. A large diameter hydraulic cylinder rod and cast load link make True Depth more durable than competitive systems and maintain a low cost of ownership.

- **Confidently handle challenging conditions** using the large-diameter hydraulic cylinder rod
- **Cost of ownership is lowered** due to cylinders that can be easily rebuilt
- **Long wear from durable cast** load link with fully potted and sealed electronics
- **Operation is simple** and maintenance is kept low with a single valve-per-row design
- **Simple system operation** is integrated into the Blue Vantage display
- **Provides lift assist** to aid in raising push row units into locked position



True Depth display

- True Depth map showing applied force as planted
- True Depth controls are integrated into the Blue Vantage display

True Depth offers lift assist on a split row planter, making it easier to raise your push row units for storage and when switching from beans to corn. This decreases the effort required to lock-up the row units by 30%, reducing operator fatigue and adjustment time.

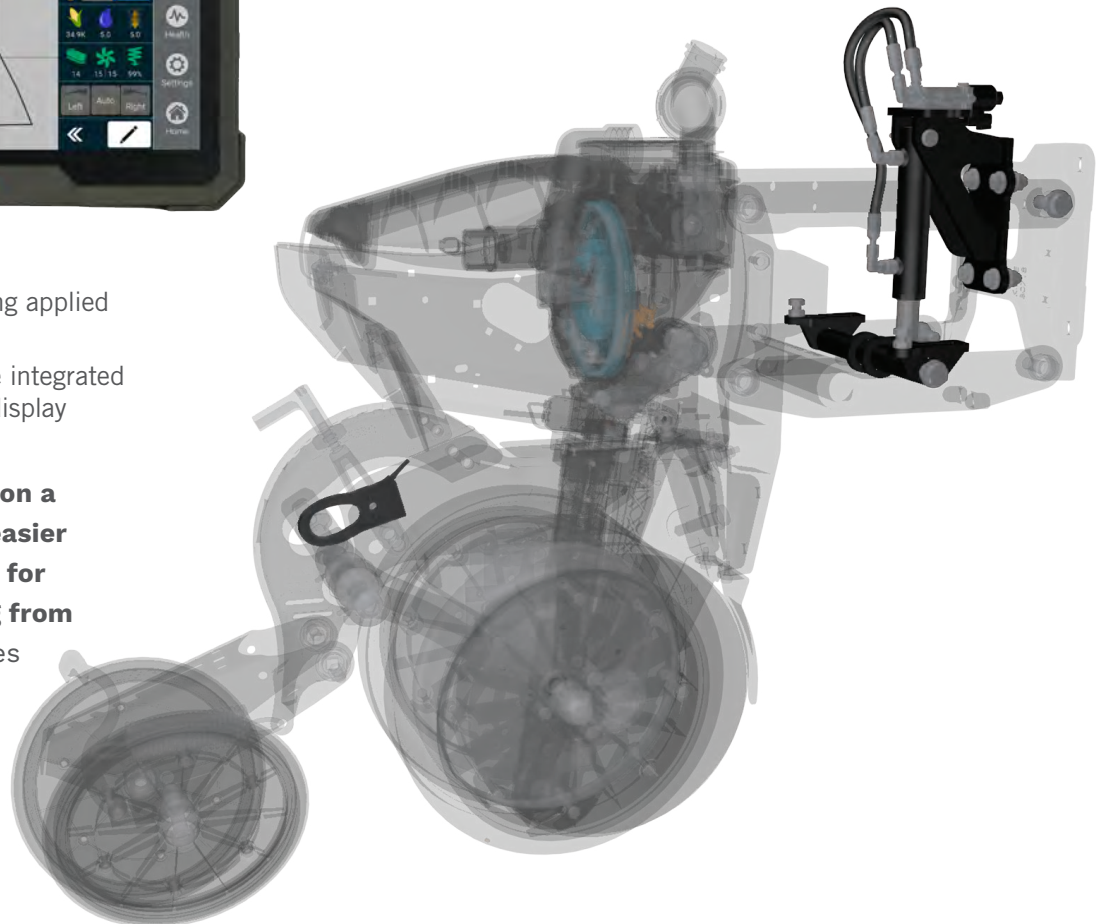

True Depth availability:
4805, 3605 and 3505

Liquid and Dry Fertilizer

Fertilizer availability

Model	Size	Seed Hopper Style	Liquid Fertilizer Capacity	Dry Fertilizer Capacity
3005	8 Row	Row Unit	1 140 L - (2) 570 L tanks	1 600 L - (2) 800 L tanks or 1 000 L - (4) 250 L tanks
	6 Row	Row Unit	1 140 L - (2) 570 L tanks	750 L - (3) 250 L tanks
3035	8 Row	Row Unit	1 140 L - (2) 570 L tanks	1 000 L - (4) 250 L tanks
3205	12 Row	Row Unit	1 515 L - (2) 575 L tanks	-
3505	8 Row	Bulk Fill ¹ 1 760 L	1 140 L ² - (2) 570 L tanks	-
	8 Row	Row Unit	1 140 L ² - (2) 570 L tanks	1 600 L ³ - (2) 800 L tanks
	6 Row	Row Unit	1 140 L ² - (2) 570 L tanks	750 L - (3) 250 L tanks
3605	16 Row	Bulk Fill ¹ 2 820 L	1 515 L - (2) 757 L tanks	-
		Row Unit	2 270 L - (4) 567 L tanks	2 820 L - (2) 1 410 L tanks or 2 000 L - (8) 250 L tanks
	12 Row	Bulk Fill ¹ 2 820 L	1 515 L - (2) 757 L tanks	-
		Row Unit	2 270 L - (4) 567 L tanks	2 820 L - (2) 1 410 L tanks or 1 500 L - (6) 250 L tanks
4805	24 Row	Bulk Fill 4 230 L	2 280 L - (2) 1 140 L tanks	3 020 L - (1 tank)
		Bulk Fill 1 760 L	-	6 130 L - (1 tank)
		Row Unit	3 800 L - (2) 1 900 L tanks	5 150 L - (1 tank)

* 1Fertilizer option not compatible with split row option, 2Fertilizer with split row or twin row are in-furrow only, 3Dry Fertilizer not available with twin row option

Fertilizer pump options

- » John Blue piston pump option with flow dividers*
 - » Hydraulically driven centrifugal pump (4805) to allow section shut-off and variable rate capability
- » Diaphragm-style pump available on Blue Vantage 3605 and 3505 machines, along with a high accuracy control valve, enable a wide range of application rates at low to high speeds

*Option includes pump mounting bracket, sprockets, drive components and flow divider.

Fertilizer tube in-furrow - Liquid

Maximize fertilizer investment with drop tubes behind seed tubes to deliver liquid fertilizer directly in the furrow. Very low fertilizer flow rate for pop-up applications. For any tillage situation—used with low fertilizer rates and lower salt content fertilizers.

Notched single disc openers - Liquid or Dry

Notched 40 cm diameter blade with adjustable down pressure – depth range 2.5 cm - 10 cm for no-till and conventional tillage. Optional depth gauge wheel for conventional till situations.

Heavy duty single disc openers - Liquid

45.75 cm diameter blade with adjustable down pressure – depth range 5 cm - 12.75 cm for no-till or conventional tillage, harsh conditions, higher application rates, and rocky soil.

Double disc openers - Liquid or Dry

38 cm diameter V-blade with adjustable coil spring down pressure. Accurate fertilizer placement. For conventional tillage & planting at speeds up to 10 km/h.

Closing Wheels



Spiked



Rubber "V"



Cast iron "V"

Row Unit Attachments

Coulter Mounted Residue Wheel

- » 31 cm free-floating diameter dual wheel system
- » 12 curved tines with interlocked or staggered mountings
- » 11 depth settings in 6 mm increments - easily adjustable
- » Requires no-till counters
- » Fairly aggressive
- » Work well in no-till and minimum-till



Spoked gauge wheels

Improved planting performance in wet conditions with easy-adjust, spoked gauge wheels equipped with long-life steel scrapers.



No-till Coulters

- » 40 cm diameter blades
- » From 19 to 25 mm
- » 3 shape option for different soil conditions



Granular chemical hoppers

Complete planting, fertilizer, AND insecticide application in one pass.



Row unit hoppers

On planters not equipped with bulk fill hoppers, durable row unit hoppers are available in two sizes.



4005 | 105 liter high-capacity row unit hopper



4005 and 3005 | 66 liter row unit hopper

Insecticide and granular chemical options available on 3005 and 4005.

Bulk fill seed delivery

More seed types. More seed sizes. More seeding rates. The 05 Series bulk fill entrainer delivers the variety of seeds you plant during a busy planting season. It's an air pressurized bulk fill seed delivery system, requiring no mechanical agitation, with capacities up to 4 230 L. The system handles various seed sizes, higher populations, and supports planting speeds up to 19 km/h. Shut off gate enables easy service or cleanout for seed remaining in the hoppers.

Electronic scale package

Bulk fill seed hoppers are weighed individually allowing operator to see weight per hopper and hectares remaining to empty. Package includes a catwalk mounted remote scale display for even filling. Bulk fill scales are required for the active weight transfer feature.



Increased crop compatibility

- Corn
- Beans
- #4 sunflowers
- Confectionery sunflowers
- Grain sorghum
- Cotton
- Canola
- Sweet corn
- Sugar beets
- Hemp
- Cover crops

THE KINZE SEED TUBE COUNTS EVERY SEED



- » High-definition, two-piece, optical seed sensor
- » Monitors multiples, skips and spacing at higher population rates
- » Automatically self-calibrates for dust
- » Instant response to population changes
- » Large seed tube minimizes seed bounce within the tube, ensuring consistent seed spacing

Hydraulic weight transfer

Hydraulic weight transfer distributes the weight from the center of the planter evenly across all rows, resulting in higher yields from less pinch row compaction.

On planters equipped with a bulk fill scale package and Blue Drive electric drive, the hydraulic weight transfer becomes ACTIVE. The weight of the bulk fill hoppers is constantly monitored, and the amount of weight transfer changes based on how much seed is in the hoppers.

Three ways field compaction reduces yield:

-  Reduces oxygen to the plant roots
-  Reduces water to plant roots
-  Restricts root development

Yield loss from pinch row compaction

The middle 6 rows of the planter next to the transport tires.

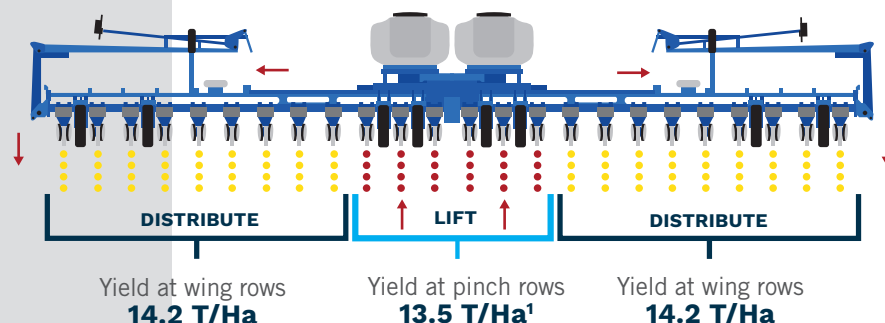

¹Data based on research from Beck's Hybrids 2014 Practical Farm Research report, available at www.beckshybrids.com.

Displays



BLUE VANTAGE

- » Built in diagnostics
- » Camera options
- » Integrated down force screens
- » Shared mapping

AG LEADER® INCOMMAND™

- » Tablet-like interaction
- » Split screen view
- » Advanced planter control



KPM III

- » Easy to use
- » Economical
- » Real-time results by row or average of the entire planter
- » Displays skips, multiples, singulation, planting rate graphs, speed and more

DISPLAY AVAILABILITY*

Model	Blue Vantage	KPM III	AG LEADER
3005	-	●	-
3035	-	●	-
3205	-	●	●
3505	●	●	-
3605	●	●	●
4805	●	-	●

*Because of ongoing technological advances, visit www.Kinze-Europe.com for the most current information on displays and monitors

Meter drives and clutches

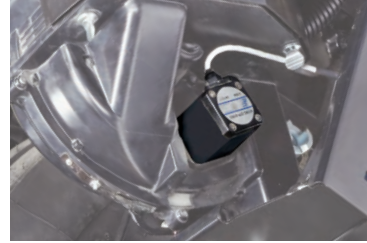

Blue Drive electric drive

No drive shafts, no chains, no clutches and no gearboxes. Available with True Speed & True Rate meters only.

Ground contact drive

Smooth, reliable and easy to operate. Uses spring-loaded tires. No clutches. No chains to remove for transport.



Electric row clutches

Clutch control, up to 36 rows, in two or three row sections. Stop seed flow by turning off seed meters (and planter sections) based on field mapping and previously planted areas.

Point row clutches for half-width planting

For ground contact drive
(Not required for electric drives).



Meter options*

Model	True Speed high speed meter	True Rate vacuum meter	Mechanical meter
3005	-	●	●
3035	-	●	●
3205	-	●	●
3505	●	●	-
3605	●	●	-
4805	●	●	-

Drive options*

Model	Blue Drive electric drive	Ground contact drive
3005	-	●
3035	-	●
3205	-	●
3505	●	●
3605	●	●
4805	●	●

*Not all features are available with all configurations. Visit www.Kinze-Europe.com/planters or your local dealer for details.

SPLIT ROWS

PLANT YOUR MAJOR CROPS WITH ONE PLANTER

Plant your major crops with a Kinze split row planter for greater accuracy. The unique combination of parallel toolbars and the Kinze exclusive push row units enable better residue flow and seed placement than other narrow row options. Plant narrow row no-till soybeans between last season's corn stalks to maximize emergence and minimize tire tread wear. Easily lock up the front row units to plant 70 cm wide row crops with the same planter.

EVEN ROW, SPLIT ROW OPTION



Planting 35 cm no-till beans between last season's cornstalks? Get more accurate seed placement and depth, a smoother planter ride, and continue to function at full planter width saving you time with the Kinze even row push unit. Decrease tire wear and tear by running tractor tires between last season's corn rows.

Exclusive Push Row Units

Available on rigid frame 3005 model and all pivot fold models.



Spring-Loaded Over-Center Row Unit Lock-Ups

Easily switch from split rows to standard width rows in minutes.

SPLIT ROW AVAILABILITY*

Model	Size	Split Row Spacing	Even Row Option
3005	6 Row 70 cm	35 cm	-
3005	8 Row 70 cm	35 cm	-
3505	8 Row 70 cm	35 cm	●
3605	12 Row 70 cm	35 cm	●
3605	13 Row 70 cm	35 cm	●

*Not all features are available with all configurations. Visit www.Kinze-Europe.com or your local dealer for details.

No-Till Wheat

Image below planted with Kinze split row technology on the left, conventional seed drill on the right; wheat planted with split row is visibly stronger because of more oxygen and nutrients compared to the wheat planted with the conventional seed drill.

Bioteks - Bulgaria, Orechovica



SPLIT ROW ADVANTAGES

Better Trash Flow

Kinze's exclusive push row units and parallel bar design allow for better residue flow resulting in better seed placement accuracy than other narrow row planters. Perfect for narrow row crops like soybeans, sunflowers, and rapeseed.

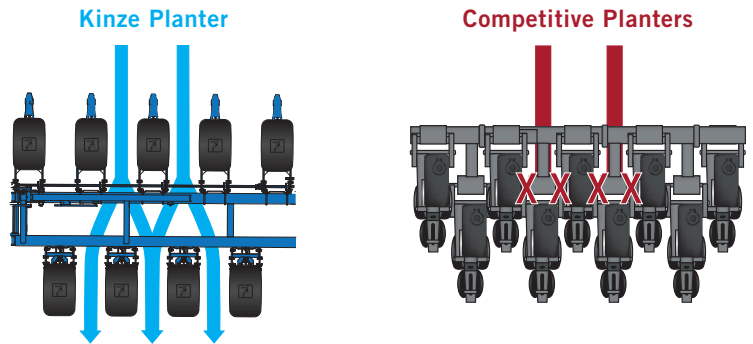

Split Row Sunflowers Out-Perform Traditional Row Spacing

In a 2017 study conducted by North Dakota State University, split row planted sunflowers out-yielded those planted in traditional wide rows by an average of 338 kg (0.338 tonnes) per hectare. At an average price of 300 € per tonne for sunflowers, this equates to 101 € more profit per hectare.*

*North Dakota State University study, "2017 Oil Sunflower Spacing & Seeding Rate Trial at Minot"

NO-TILL ADVANTAGE¹



Excellent
Erosion Control

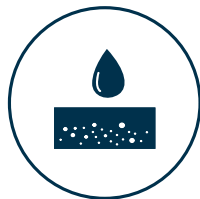

Soil Moisture
Conservation



Minimum Fuel
& Labor Costs



Builds Soil
Structure & Health

No-Till Soybeans Out Yield Conventional Tillage

Averaged over three years, in 4 out of 6 studies, soybeans averaged yield differences that ranged from 25 to 94 kg/ha.²

¹University of Nebraska-Lincoln, Institute of Agriculture and Natural Resources, CropWatch
²Farm Progress

No-Till Wheat

Planted with Kinze 3605 at 35 cm
with liquid fertilizer
-Moldova, Cupcini

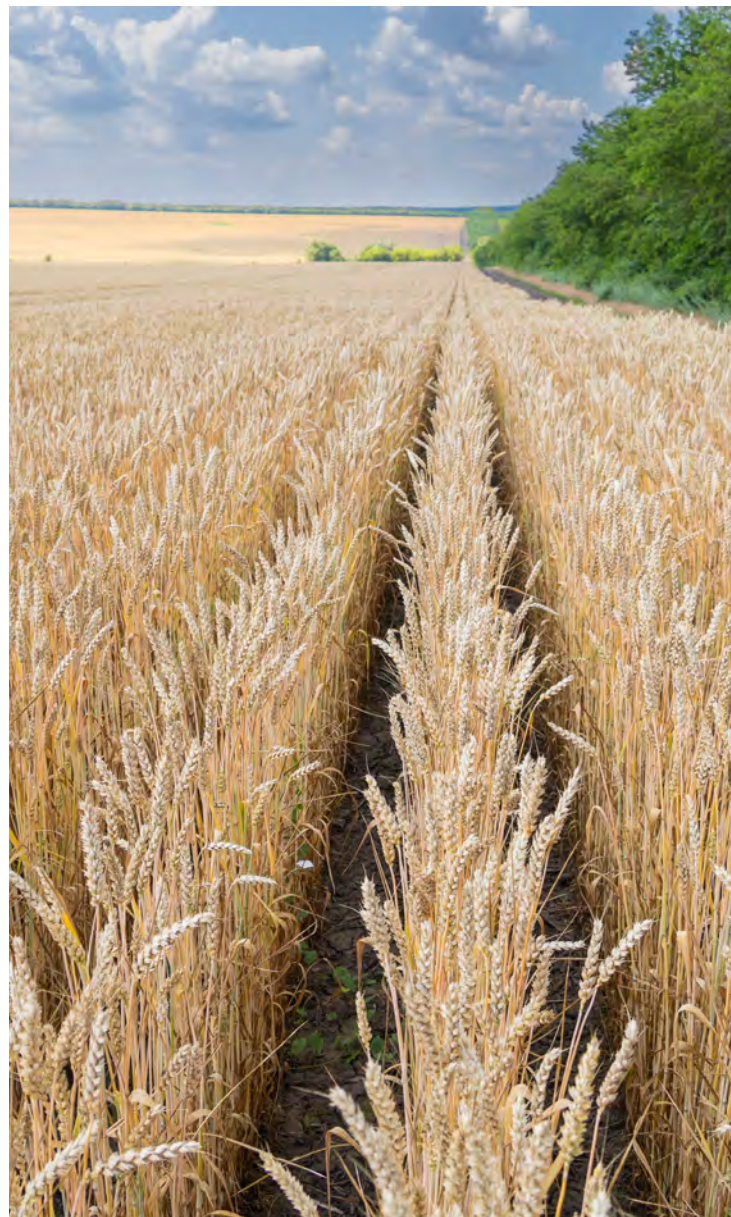

3005 SERIES

- **Hardened, replaceable large diameter double parallel arm bushings** have more wear area and are oil impregnated for double the wear life and to eliminate parallel arm replacement
- **Inner scraper material upgraded** for twice the wear life
- **Load equalizing gauge wheels** for uniform depth control, even in heavy residue or rugged planting conditions
- **Down force options** depending on configuration

3005 SERIES Row unit features

- 1 Reinforced heavy-duty shanks for maximum side load strength
- 2 25 cm of vertical travel handles changing fields conditions
- 3 Double parallel arm bushings with larger wear areas for long life
- 4 Disc opener with double-row bearings for increased service life
- 5 Disc opener scraper material has double the service life
- 6 True Speed scraper improved material for extended wear-life

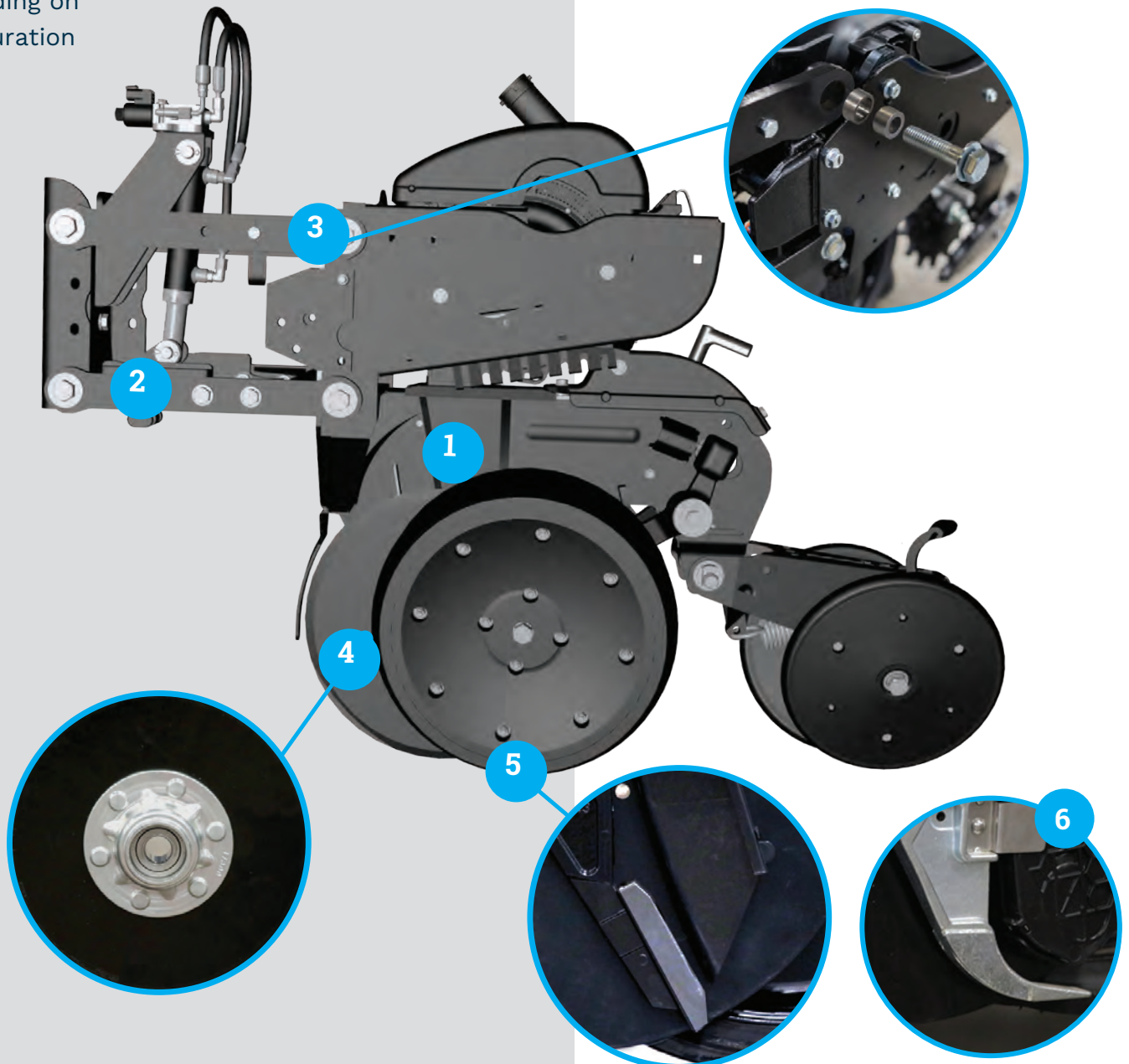

4005 SERIES

- **Hardened, replaceable large diameter double parallel arm bushings** have more wear area and are oil impregnated for double the wear life and to eliminate parallel arm replacement
- **Inner scraper material upgraded** for twice the wear life
- **Load equalizing gauge wheels** for uniform depth control, even in heavy residue or rugged planting conditions
- **Down force options** depending on configuration

4005 SERIES Row unit features

- 1 **Cast iron heavy-duty shanks** for greater reliability and durability
- 2 **30.5 cm of vertical travel handles** changing fields conditions
- 3 **Double parallel arm bushings** with larger wear areas for long life
- 4 **Disc opener with double-row bearings** for increased service life
- 5 **Disc opener scraper material** has double the service life
- 6 **True Speed scraper** improved material for extended wear-life

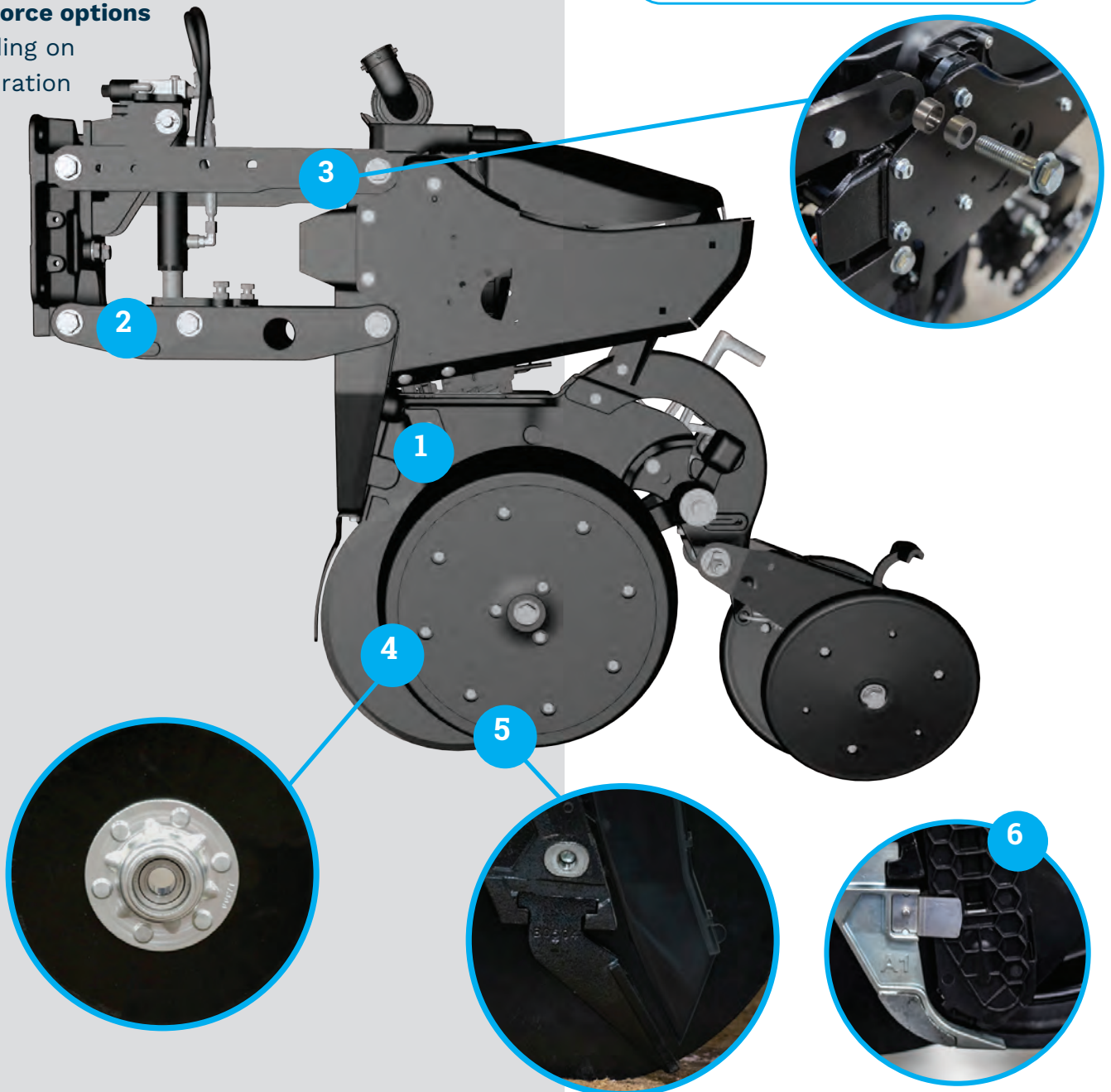

MODEL REVIEW

RIGID FRAME



3005



3115 (Mounted)

WING FOLD



3035



3205

PIVOT FOLD



3505



3605

FRONT FOLD



4805



A model of versatility of what we put in all our planters, the 3005 Kinze planter is an adaptable, small-frame hitch pin planter. Its bolt-together design can easily switch from standard to split rows and converts from 70 cm to 35 cm row spacing in minutes. When equipped with double frame, it can be outfitted with dry or liquid fertilizer along with optional split rows. Lower inputs and equipment costs up front allow you to customize and configure the 3005 planter to match your farm.

- Improved durability, longer wear life, and lower cost of ownership from O5 Series row unit upgrades
- Accuracy at speeds up to 13 km/h, as field conditions allow, with the True Rate vacuum meter
- Efficient fertilizer application with up to 1 140 L of liquid or up to 1 600 L of dry fertilizer capacity
- Optional double frame enables both split row and fertilizer options at the same time
- Contact drive system with easy-access seed rate transmissions
- Plant both wide and narrow row width crops with split row option
- Rigid frame design with self-leveling hitch

Features & options²

True Rate vacuum seed meter

O5 Series row unit enhancements

Ground contact drive

Finger pick-up meter

Brush meter

Rigid frame

Self-leveling hitch

Split rows

Liquid fertilizer available on 8R Split Row

Dry fertilizer

¹Minimum tractor power requirement dependent upon planter configurations and chosen options.

²Not all features are available with all configurations. Visit www.Kinze-Europe.com/planters or your local dealer for details.



The 3035 Kinze planter is a feature-packed narrow transport solution for many farms where narrow transport width is critical for navigating narrow roads or getting in to smaller fields. The double frame wing fold design, that enables the use of dry or liquid fertilizer, provides maximum versatility in a small package.

- Improved durability, longer wear life, and lower cost of ownership from O5 Series row unit upgrades
- Accuracy at speeds up to 13 km/h, as field conditions allow, with the True Rate vacuum meter
- Contact drive system with easy-access seed rate transmissions
- Efficient fertilizer application with up to 1 140 L of liquid or up to 1 000 L of dry fertilizer capacity
- Fertilizer openers and row units on wings fold together for a narrow transport width of 2.95 m

Features & options²

True Rate vacuum seed meter

O5 Series row unit enhancements

Ground contact drive

Narrow transport width

Finger pick-up meter

Brush meter

Wing fold frame

Liquid fertilizer

Dry fertilizer

¹Minimum tractor power requirement dependent upon planter configurations and chosen options.

²Not all features are available with all configurations. Visit www.Kinze-Europe.com/planters or your local dealer for details.



A robust, durable, and productive planter, the 3115 mounted planter is perfect for smaller operations. It is the only rigid frame mounted planter with contact drive and self-contained seed rate transmissions. Great in smaller fields, this 6- or 8-row planter mounts to your tractor or other implements for ridge-till and strip-till management practices. Can be equipped with True Rate vacuum meters, finger pick-up meters, or brush meters.

- Improved durability, longer wear life, and lower cost of ownership from O5 Series row unit upgrades
- Accuracy at speeds up to 13 km/h, as field conditions allow, with the True Rate vacuum meter
- Adjustable toolbar height for flatland or bedded fields
- Contact drive system with easy-access seed rate transmissions
- Economical planter with minimal hydraulic requirements and low cost of ownership

Features & options²

True Rate vacuum seed meter

O5 Series row unit enhancements

Brush meter

Ground contact drive

Finger pick-up meter

Rigid mounted frame

¹Minimum tractor power requirement dependent upon planter configurations and chosen options.

²Not all features are available with all configurations. Visit www.kinze-europe.com/planters or your local dealer for details.



The 3205 wing fold planter is an economical solution for many operations—perfect for the farmer moving from a 6-row to a 12-row planter or a growing operation in need of a second planter for smaller field sizes. Standard ground contact drive works seamlessly with True Rate vacuum meters for accurate seed placement. Wing fold frame provides center flex for terraces and rolling terrain; the proven design has minimal hydraulic requirements and low cost of ownership.

- Improved durability, longer wear life, and lower cost of ownership from 05 Series row unit upgrades
- Accuracy at speeds up to 13 km/h as field conditions allow, with the True Rate vacuum meter
- Efficient fertilizer application with up to 1 515 L of liquid fertilizer capacity
- Easily navigate terraces and rolling terrain with the wing fold frame design incorporating 25 degrees of center flex
- Economical planter with minimal hydraulic requirements and low cost of ownership

Features & options²

True Rate vacuum seed meter

05 Series row unit enhancements

Ground contact drive

18 cm x 18 cm toolbar

25 degrees toolbar flex

Wing fold frame

Brush meter

Finger pick-up meter

Electric clutches

Liquid fertilizer

¹Minimum tractor power requirement dependent upon planter configurations and chosen options.

²Not all features are available with all configurations. Visit www.Kinze-Europe.com/planters or your local dealer for details.



MINIMUM¹
100 HP

Uniquely positioned as a small frame basic or advanced technology planter for smaller farms or small fields, the Kinze 3505 pivot fold planter, with split rows or 17.5 cm twin rows, is simple to operate, high performing, and now available with True Speed high speed meters. Performance optimized with other optional high tech features—Blue Vantage display, Blue Drive electric drive, and True Depth hydraulic down force—it accurately places your seed for increased productivity and profits at speeds up to 19 km/h.

- True high-performance split row planting achieved with True Speed high speed or True Rate vacuum meters and Blue Drive electric drive
- Simple and easy to use Blue Vantage display with Map Sync™ shared field coverage data, and up to four cameras
- Consistent seed depth control with the optional True Depth hydraulic down force system
- Exceptional seed handling capabilities with upgraded bulk fill entrainer—up to 11 different crops
- Fewer stops with 1 760 L bulk fill hopper
- Accuracy at speeds from 5-19 km/h, as field conditions allow, to plant up to twice the number of hectares in a day with the True Speed vacuum meter
- Narrow transport and easy serviceability achieved with double frame, lift and pivot folding frame design
- Improved durability, longer wear life, and lower cost of ownership from O5 Series row unit upgrades
- Efficient fertilizer application with up to 1 140 L of liquid or 1 600 L of dry fertilizer capacity

Features & options²

True Speed high speed meter

Blue Drive electric drive and Blue Vantage display

True Depth hydraulic down force

Liquid or Dry Fertilizer; Blue Vantage controlled Liquid Fertilizer

Split row (available with fertilizer)

Up to 4 planter mounted cameras

True Rate vacuum seed meter

Narrow transport

Opt. Electric Clutches

Twin row 17.5 cm spacing on 70 cm centers

Ground contact drive

Electric single row control

Pneumatic down pressure

¹Minimum tractor power requirement dependent upon planter configurations and chosen options.

²Not all features are available with all configurations. Visit www.Kinze-Europe.com/planters or your local dealer for details.

HIGH TECH



PLANTER



Less than 3.2 meter transport width in 70 cm configurations

MINIMUM¹
240 HP

Outfitted with split row units, the 3605 is uniquely suited as a dedicated 35 cm soybean planter, along with the versatility to plant crops in 70 cm rows. Equipped with dry or liquid fertilizer, bulk fill or row unit hoppers, and simple to use high tech features — Blue Vantage display, Blue Drive electric drive, and True Speed high speed meters — it delivers the precision required for maximum yields and profits at speeds up to 19 km/h.

- True high-performance and accurate planting with True Speed or True Rate vacuum meters and Blue Drive electric drive
- Simple and easy to use Blue Vantage display with Map Sync™ shared field coverage data, and up to four cameras
- Improved durability, longer wear life, and lower cost of ownership from O5 Series row unit upgrades
- Exceptional seed handling capabilities with upgraded bulk fill entrainer — up to 11 different crops
- Consistent seed depth control with the durable True Depth hydraulic down force system
- Follow rolling terrain with a 3-section pivot fold frame with 14 degrees of wing flex
- Reduced pinch row compaction with 2 820 L bulk fill seed capacity with a hydraulic weight transfer system
- Narrow transport and easy serviceability achieved with double frame, lift and pivot folding frame design
- Efficient fertilizer application with up to 2 270 L of liquid or 2 820 L of dry fertilizer capacity
- Plant narrow row width crops with split row option

Features & options²

True Speed high speed meter

True Depth hydraulic down force

Active³ hydraulic weight transfer

Blue Vantage controlled liquid fertilizer

Blue Drive electric drive and Blue Vantage display

True Rate vacuum seed meter

Up to 4 planter mounted cameras

Narrow Transport

Split row

Liquid or dry fertilizer

Articulating clevis hitch



¹Minimum tractor power requirement dependent upon planter configurations and chosen options.

²Not all features are available with all configurations. Visit www.Kinze-Europe.com/planters or your local dealer for details.

³Active hydraulic weight transfer only with bulk fill scales and Blue Drive.



MINIMUM¹
400 HP

Equipped with Blue Vantage display, Blue Drive electric drive, True Speed high speed meters, rugged cast row units, and True Depth hydraulic down force, the 4805 delivers unrivaled seed control and placement at speeds up to 19 km/h. The front fold, 3 section, high clearance frame, equipped with larger front mounted tires and transfer, supports large seed and fertilizer capacities while reducing pinch row compaction.

- True high-performance and accurate planting with True Speed or True Rate vacuum meters and Blue Drive electric drive
- Simple and easy to use Blue Vantage display with Map Sync™ shared field coverage data, and up to four cameras
- Improved durability, longer wear life, and lower cost of ownership from 05 Series row unit upgrades
- Reduced pinch row compaction from bulk fill with an active hydraulic weight transfer system
- Fewer stops and improved efficiency with up to 3 800 L liquid fertilizer controlled by Blue Vantage or up to 6 130 L dry fertilizer on board
- Lower tractor hydraulic requirements and only two SCVs required with PTO variable displacement pump
- Follow rolling terrain easily with a 3-section front fold frame with 30 degrees of wing flex
- Hydraulic wing locks and best in class transport clearance for easy and safe road transport

Features & options²

True Speed high speed meter

Blue Drive electric drive and Blue Vantage display

Cast row unit

True Depth hydraulic down force

Active³ hydraulic weight transfer

Bulk fill seed hopper

True Rate vacuum seed meter

Up to 4 planter mounted cameras

High transport clearance

Liquid or dry fertilizer

Articulating clevis hitch



¹Minimum tractor power requirement dependent upon planter configurations and chosen options.

²Not all features are available with all configurations. Visit www.Kinze-Europe.com/planters or your local dealer for details.

³Active hydraulic weight transfer only with bulk fill scales and Blue Drive.



Onboard Liquid or Dry Fertilizer

Efficiently apply liquid or dry fertilizer without pulling a cart or performing a separate operation. The 4805 can be outfitted with 2 280 L or 3 800 L¹ of liquid fertilizer, or with 3 020 L, 5 150L, or 6 130 L² of dry fertilizer to match your farming practices. Application is with durable notched single disc openers for both conventional or no-till planting.

¹Capacity dependent upon configuration

²Dry fertilizer system is unique by it's fertilizing dosing accuracy



Effortless Fold and Unfold



4005 SERIES FEATURES & OPTIONS

● = Standard ● = Optional

Feature/Option	4805
Planter Frame/Toolbar	Front Fold
Sections	3
Number of rows per Wing	9
Flexibility	Center Flex 15° up / 15° down
Row markers	●
Hydraulic weight transfer (active hydraulic weight transfer w/bulk fill scale and Blue Drive)	●
Articulating clevis hitch	●
PTO Hydraulic Package	●
Seed Handling	
Row Unit Seed Hoppers	66 L or 105 L
Bulk Fill Seed Hoppers	4 230 L
Bulk Fill Scale Package	●
Transmission/Drive System	
Blue Drive Electric Drive	●
Ground Contact Drive	●
Displays & Control	
Blue Vantage Display (standard with Blue Drive)	●
Single Row Section Control (standard with Blue Drive)	●
Ag Leader InCommand	●
Ag Leader 7500 GPS Receiver	●
Metering	
True Speed High Speed Meter (bulk fill only)	●
True Rate Vacuum Meter	●
Row Units	●
Rubber V Closing Wheels	
Cast Iron Closing Wheels	●
Spiked Closing Wheels	●
Spoked Gauge wheels	●
True Depth Hydraulic Down Force	●
Heavy Duty Down Pressure Springs	●
Pneumatic Down Pressure	●
Row Unit Mounted No Till Coulters	●
Residue Wheels	●
Granular Chemical Attachments	●
Fertilizer	
Liquid Fertilizer Packages	●
Dry Fertilizer Packages	●
Notched Single Disc Opener Pkg	●
Liquid Fertilizer Tube In-Furrow	●
Miscellaneous	
Transport Lights and Signs	●
Auxiliary Work Light Package	●
Safety Chain (Drawbar Hitch)	●
Parking Jack	●
Rear Trailer Hitch	●

3005 SERIES FEATURES & OPTIONS

● = Standard ● = Optional

Feature/Option	3605	3505	3205	3115	3035	3005
Planter Frame/Toolbar						
	Pivot Fold	Pivot Fold	Wing Fold	Rigid/Mounted	Wing	Rigid
Sections	3	1	2	1	3	1
Flexibility	Wing Flex 7° up / 7° down	Rigid	Center Flex 13° up / 12° down	Rigid	Rigid	Rigid
Split Rows	●	●	–	–	–	●
Even Row Split Row	●	●	–	–	–	–
Twin Rows	–	●	–	–	–	–
Row Markers	●	●	●	●	●	●
Hydraulic Weight Transfer (active hydraulic weight transfer w/ bulk fill scale and Blue Drive)	●	–	–	–	–	–
Hitch	Articulating Clevis	Clevis	Clevis	3-point	Clevis	Clevis
2-point Adapter	●	●	–	–	–	–
PTO Hydraulic Pump	●	●	●	–	●	●
Seed Handling						
Row Unit Seed Hoppers	●	●	●	●	●	●
Bulk Fill Seed Hoppers	2 820 L	1 760 L	–	–	–	–
Bulk Fill Scale Package	●	–	–	–	–	–
Transmission / Drive System						
Ground Contact Drive	●	●	●	●	●	●
Blue Drive Electric Drive	●	●	–	–	–	–
Displays and Controls						
Blue Vantage Display (std w/Blue Drive)	●	●	–	–	–	–
Electric Single Row Control	●	●	–	–	–	–
KPM III Electronic Seed Monitor	●	●	●	●	●	●
Ag Leader InCommand	●	–	●	–	–	–
GPS Autoswath or Manual Control	●	●	●	–	–	–
Electric Single Row Clutches (2 row shut-off for Ag Leader)	●	●	●	–	–	–
Metering						
True Speed High Speed Meter	● (bulk fill)	● (bulk fill)	–	–	–	–
True Rate Vacuum Meter	●	●	●	●	●	●
Mechanical Finger Pick-up	–	–	●	●	●	●
Mechanical Brush Meter	–	–	●	●	●	●
Row Units						
Rubber V or Cast Iron Closing Wheels	●	●	●	●	●	●
Spiked closing wheels	●	●	●	●	●	●
Spoked gauge wheels	●	●	●	●	●	●
True Depth Hydraulic Down Force	●	●	–	–	–	–
Heavy Duty Down Pressure Springs	●	●	●	●	●	●
Pneumatic Down Pressure	●	●	–	–	–	–
Row Unit Mounted No Till Coulters	●	●	●	●	●	●
Residue wheels	●	●	●	●	●	●
Granular chemical w/hopper	●	●	●	●	●	●
Fertilizer						
Liquid Fertilizer Packages	●	●	●	–	●	●
Dry Fertilizer Packages	●	●	–	–	●	●
Double Disc Opener Package	●	●	●	–	●	●
Heavy Duty or Notched Single Disc Opener Pkg	●	●	●	–	●	●
Liquid Fertilizer Tube In-Furrow	●	●	●	–	●	●
Liquid Fertilizer Pump Packages	●	●	●	–	●	●
Miscellaneous						
Transport Lights and Signs	●	●	●	●	●	●
Auxiliary Work Lights	●	●	–	–	–	–
Safety Chain and Parking Jack	●	●	●	●	●	●
Rear Trailer Hitch	●	●	–	–	–	–

MODEL DIMENSIONS AND WEIGHTS

	4805	3605		3505
	24R 70 CM	16 ROW 70 CM	12 ROW 70 CM	8 ROW 70 CM
Length ¹				
Planting - Row Unit Hoppers	-	7.3 m	6.4 m	6.1 m
Planting - Bulk Fill Hoppers	9.3 - 10 m	7.3 m	6.4 m	6.1 m
Transport - Row Unit Hoppers	-	13.3 m	10.5 m	7.6 m
Transport - Bulk Fill Hoppers	13.5 - 14.5 m	13.3 m	10.5 m	7.6 m
Width ¹				
Planting - Row Unit Hoppers	-	11.7 m	9.0 m	6.1 m
Planting - Bulk Fill Hoppers	17.5 m	11.7 m	9.0 m	6.1 m
Transport - Row Unit Hoppers	-	3.2 m	3.2 m	3.1 m
Transport - Bulk Fill Hoppers	4.8 - 5.5 m	3.2 m	3.2 m	3.1 m
Height ¹				
Planting - Row Unit Hoppers	2.2 m	-	-	2.5 m
Planting - Bulk Fill Hoppers	3 - 3.1 m	2.5 m	2.5 m	2.6 m
Transport - Row Unit Hoppers	3 m	3.5 m	3.5 m	3.4 m
Transport - Bulk Fill Hoppers	3.8 - 3.9 m	3.8 m	3.8 m	3.7 m
Weight (empty) ¹				
Base machine - Row Unit Hoppers	12 950-13 050 kg	7 135-7 350 kg	5 795-5 980 kg	3 100-3 300 kg
Base machine - Bulk Fill Hoppers	14 570-17 270 kg	7 075-7 730 kg	6 615-6 915 kg	3 600-3 800 kg
Hitch - Bulk Fill Hoppers, in transport	5 000-5 500 kg	1 750 kg	1 425 kg	-
Hitch - Row Unit Hoppers, in transport	-	925 kg	1 590 kg	-
Weight (full/planting) ¹				
Hitch - Bulk Fill Hoppers	1 000-3 500 kg	-	-	-

	3205	3115		3035	3005	
	12 ROW 70 CM	8 ROW 70 CM	6 ROW 70 CM	8 ROW 70 CM	8 ROW 70 CM	6 ROW 70 CM
Length ¹						
Planting - Row Unit Hoppers	5.4 m	1.6 m	1.6 m	6.8 m	3.5 m / 4.2 m ²	3.5 m / 4.2 m ²
Transport - Row Unit Hoppers	5.4 m	1.6 m	1.6 m	6.6 m	3.5 m / 4.2 m ²	3.5 m / 4.2 m ²
Width ¹						
Planting - Row Unit Hoppers	9.6 m	6.7 m	4.5 m	5.5 m	6.7 m	4.5 m
Transport - Row Unit Hoppers	4.9 m	6.7 m	4.5 m	3.0 m	6.7 m	4.5 m
Height ¹						
Planting - Row Unit Hoppers	-	-	-	2.8 m	-	-
Transport - Row Unit Hoppers	2.8 m	-	-	3.2 m	-	-
Weight (empty) ¹						
Base machine - Row Unit Hoppers	3 400-3 660 kg	1 400-1545 kg	1 1125-1255 kg	3 500-3 760 kg	2 210-2 515 ¹ kg	1 750-1 995 ¹ kg
Hitch - Row Unit Hoppers	350 kg	-	-	-	-	-



PLANTING INNOVATIONS FROM FARMERS FOR FARMERS

From a humble 140-square-meter shop to a state-of-the-art 65-hectare manufacturing campus, Kinze has remained laser-focused on developing innovative agricultural equipment by listening to what customers have to say. From Jon Kinzenbaw's first day in the welding shop in 1965, the needs of the customer have always been, and will continue to be, of the utmost importance to Kinze. The only question is what will be next?

The technology of planting is changing at an ever-increasing pace, and Kinze is constantly introducing new features and improvements to increase the precision, speed, and productivity of the most important job of the year. **To learn about the latest technology in planters and try it out for yourself, we invite you to be our guests at the Kinze Europe factory and demonstration grounds. Contact us by filling out a form at Kinze-Europe.com/about/contact-us.**

KINZE®

Kinze Manufacturing, Inc. • 2172 M Ave
Williamsburg, Iowa 52361-0806 USA • Kinze.com

Kinze Europe UAB
Guopstu Road 17 • Guopstu Village
LT-21148 Trakai District Lithuania • Kinze-Europe.com



Authorized Dealer:

© 2025 by Kinze Manufacturing, Inc. Kinze®, the Kinze® logo, are trademarks owned by Kinze Manufacturing, Inc. Kinze Manufacturing, Inc. reserves the right to make changes in engineering, design and specifications, or add improvements at any time without notice or obligation.

MY2026 04.2025