



EUROPEAN DECLARATION OF CONFORMITY

Kinze Manufacturing
2172 M Avenue
Williamsburg, IA 53261

Kinze Europe UAB
Guopstu k., Senuju Traku sen
LT-21148 Traku r., Lithuania

We, Kinze Manufacturing and Kinze Europe UAB declare, under our sole responsibility, the following products – agricultural planter models 3005, 3035, 3115, 3145, 3205, 3505, 3605, 3665, 3705, 4805, and 4905 – to which this declaration relates, are in conformity with the applicable provisions of the following standards, other normative documents and Directives, as appropriate by version and model:

2006/42/EC; EN 1037:1995+A1:2008; EN ISO 13850:2008; EN ISO 13857:2008; EN 349:1993+A1:2008; EN 547-1:1996+A1:2008; EN 547-2:1996+A1:2008; EN 547-3:1996+A1:2008; EN ISO 13732-1:2008; EN 614-1:2006+A1:2009; EN 614-2:2000+A1:2008; EN 953:1997+A1:2009; EN ISO 13849-1:2008; EN ISO 13849-2:2012; EN ISO 4254-1; EN ISO 12100:2010; EN ISO 4413:2010.

The Technical Construction File is maintained at: Kinze Manufacturing, Inc., 2172 M Avenue, Williamsburg, Iowa, USA, 52361-0806.

The authorized representative located within the community is: Edvardas Melys, Kinze Europe UAB, Guopstu k., Senuju Traku sen, LT-21148 Traku r., Lithuania.

Place of Issue: Kinze Manufacturing Inc., Williamsburg, Iowa, USA.

Date of Issue: 20200821 | August 21, 2020

Signed on behalf of Kinze Manufacturing Inc. and Kinze Europe UAB:

Jay D. Grimes

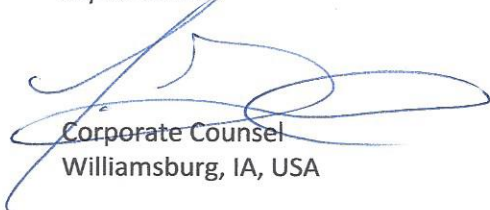

Corporate Counsel
Williamsburg, IA, USA



Kinze Manufacturing, Inc.



СЕРТИФИКАТ СООТВЕТСТВИЯ

№ ЕАЭС RU C-US.АД07.В.02342/20

Серия **RU** № **0225035**

ОРГАН ПО СЕРТИФИКАЦИИ Орган по сертификации Общество с ограниченной ответственностью «Центр Сертификации «ВЕЛЕС». Место нахождения (адрес юридического лица): 195009, РОССИЯ, город Санкт-Петербург, улица Академика Лебедева, дом 12, корпус 2, литера А, этаж 2, комната 26. Адрес места осуществления деятельности: 190068, РОССИЯ, город Санкт-Петербург, переулок Никольский, дом 4 литер А, помещение 8Н. Уникальный номер записи об аккредитации в реестре аккредитованных лиц № RA.RU.10АД07. Дата решения об аккредитации: 24.03.2016. Телефон: +74952211810 Адрес электронной почты: info@velessert.ru

ЗАЯВИТЕЛЬ ОБЩЕСТВО С ОГРАНИЧЕННОЙ ОТВЕТСТВЕННОСТЬЮ "МИР ТЕХНОЛОГИЙ"
Место нахождения (адрес юридического лица) и адрес места осуществления деятельности: 117042, Россия, город Москва, улица Адмирала Руднева, дом 4, этаж 6, помещение IV, офис 613
Основной государственный регистрационный номер 1187746469096.
Телефон: 89154152183. Адрес электронной почты: MirTekhnology@gmail.com

ИЗГОТОВИТЕЛЬ KINZE Manufacturing, Inc.
Место нахождения (адрес юридического лица): Соединенные Штаты, 2172 M Avenue, Williamsburg, IA 52631-0806
Филиал изготовителя: KINZE Europe, UAB Литва, Guopstu kelias 17, Guopstos, LT-21148 Traku rajonas

ПРОДУКЦИЯ Машины сельскохозяйственные: сеялка точного высева торговой марки KINZE, моделей: 3000, 3005, 3030, 3035, 3110, 3115, 3140, 3145, 3200, 3205, 3500, 3505, 3600, 3605, 3660, 3665, 3700, 3705, 4700, 4705, 4800, 4805, 4900, 4905.
Продукция изготовлена в соответствии с Директивой 2006/42/ЕС «Машины и механизмы».

Серийный выпуск

КОД ТН ВЭД ЕАЭС 8432311100

СООТВЕТСТВУЕТ ТРЕБОВАНИЯМ

Технического регламента Таможенного союза "О безопасности машин и оборудования" (ТР ТС 010/2011)

СЕРТИФИКАТ СООТВЕТСТВИЯ ВЫДАН НА ОСНОВАНИИ протокола испытаний № 1023/3АТС-2020 от 27.10.2020 года, выданного Испытательной лабораторией «АвтоТракторные Средства» Общество с ограниченной ответственностью «ПРОММАШ ТЕСТ» (регистрационный номер аттестата аккредитации RA.RU.21НА71) акта анализа состояния производства от 21.09.2020 года, выданного Органом по сертификации Общество с ограниченной ответственностью «Центр Сертификации «ВЕЛЕС» обоснования безопасности; руководства по эксплуатации; паспорта

Схема сертификации: 1с

ДОПОЛНИТЕЛЬНАЯ ИНФОРМАЦИЯ ГОСТ Р 53489-2009 "Система стандартов безопасности труда. Машины сельскохозяйственные навесные и прицепные. Общие требования безопасности" разделы 4 и 5. Срок службы, срок и условия хранения указаны в эксплуатационной документации, приложенной к изделию.

СРОК ДЕЙСТВИЯ С 28.10.2020 **ПО** 27.10.2025
ВКЛЮЧИТЕЛЬНО

Руководитель (уполномоченное
лицо) органа по сертификации

Эксперт (эксперт-аудитор)
(эксперты (эксперты-аудиторы))

(подпись)

(подпись)

Родзинов Галина Александровна (Ф.И.О.)
Киряенко Константин Борисович (Ф.И.О.)

This page left blank intentionally.

TO THE DEALER

Preelivery service includes assembly, lubrication, adjustment and test. This service helps to ensure planter is delivered to retail customer/end user ready for field use.

PREDELIVERY CHECKLIST

After the planter is completely assembled, use the following checklist and inspect the planter. Check off each item as it is found satisfactory or after proper adjustment is made.

- Row units properly spaced and optional attachments correctly assembled.
- All grease fittings in place and lubricated.
- All working parts are moving freely. Bolts are tight and cotter pins are spread.
- All drive chains properly tensioned and aligned.
- Check for oil leaks and proper hydraulic operation.
- Hydraulic hoses are routed correctly to prevent damage to hoses.
- Inflate tires to specified air pressure. Tighten wheel lug bolts to specified torque.
- All safety decals correctly located and legible as shown in Parts Manual. Replace if damaged.
- All reflective decals and SMV sign located as shown in Parts Manual and visible when planter is in transport position.
- Safety/warning lights correctly installed and working properly.
- Paint all parts scratched in shipment or assembly.
- All safety lockup devices are on planter and correctly located.
- Seed meters performance checked on test stand.
- Auxiliary safety chain is properly installed and hardware is torqued to specification.

Planter has been thoroughly checked and to the best of my knowledge is ready for delivery to the customer.

(Signature Of Set-Up Person/Dealer Name/Date)

OWNER REGISTER

Name _____ Delivery Date _____

Street Address _____ Model No. 3205 Serial No. _____

City, State/Province _____ Dealer Name _____

ZIP/Postal Code _____ Dealer No. _____

DELIVERY CHECKLIST

Use the following checklist at time planter is delivered as a reminder of very important information which should be conveyed to retail customer/end user. Check off each item as it is fully explained.

- Check for proper operation of vacuum fan (If Applicable) with tractor to be used with planter.
- Life expectancy of this or any other machine is dependent on regular lubrication as directed in the Operator Manual.
- All applicable safety precautions.
- Along with retail customer/end user, check reflective decals and SMV sign are clearly visible with planter in transport position and attached to tractor. Check safety/warning lights are in working condition. Tell retail customer/end user to check federal, state/provincial, and local regulations before towing or transporting on a road or highway.
- Give Operator Manual, Parts Manual, and all Instruction Sheets to retail customer/end user and explain all operating adjustments.
- Read warranty to retail customer/end user.
- Complete Warranty and Delivery Report form.

To the best of my knowledge this machine has been delivered ready for field use and customer has been fully informed as to proper care and operation.

(Signature Of Delivery Person/Dealer Name/Date)

AFTER DELIVERY CHECKLIST

The following is a list of items we suggest to check during the first season of use of the equipment.

- Check planter performance with retail customer/end user.
- Check performance of vacuum or mechanical seed metering system with retail customer/end user.
- Review importance of proper maintenance and adherence to all safety precautions with retail customer/end user.
- Check for parts that may need to be adjusted or replaced.
- Check all safety decals, reflective decals, and SMV sign are correctly located as shown in the Parts Manual and that decals are legible. Replace if damaged or missing.
- Check safety/warning lights are working properly.

(Signature Of Follow-Up Person/Dealer Name/Date)

**All registrations must be submitted online at "business.kinze.com" within 5 business days of delivery.
Retain a copy of this form for auditing purposes.**

Tear Along Perforation

OVERVIEW

To the Owner	1-1
Warranty	1-3
General Information	1-4
Specifications	1-5
Tractor Hydraulic Requirements	1-5
General Safety Rules	1-6
Safety Precautions	1-7
Safety Instructions, Signs, and Decals	1-8

MACHINE OPERATION

Lift Cylinder Lockups	2-1
Wing Safety Pins	2-1
Hydraulic Operation	2-2
Initial Preparation	2-4
Tractor Requirements	2-5
Tractor Preparation and Hookup	2-5
Level Planter	2-6
Cylinder Information	2-7
Hydraulic Hose Information	2-8
Manual Wing Fold Transport to Field Operation	2-9
Manual Wing Fold Field Operation to Transport	2-10
Hydraulic Wing Fold Transport to Field Operation	2-11
Hydraulic Wing Fold Field Operation to Transport	2-13
Hydraulic Row Marker Operation	2-15
Row Marker Speed Adjustment	2-16
Row Marker Adjustment	2-17
Transporting Planter	2-18
Contact Drive Spring Adjustment	2-18
Wrap Spring Wrench	2-19
Contact Wheel Drive Sprockets	2-19
Seed Rate Transmission Adjustment	2-20
Standard and Half Rate (2 to 1) Drives	2-20
Shear Protection	2-21
Tire Scraper	2-21
Ridge Planting	2-21
Point Row Clutches	2-22
Ag Leader Integra Display	2-23
Ag Leader Monitoring Control Package (PMM)	2-23
Ag Leader InCommand 1200 Display	2-23
AG Leader Electric Clutches	2-23
Field Test	2-24
Check Seed Population	2-24
Determining Kilograms Per Hectare (Brush-Type Meter)	2-25
Determining Liters Per Hectare	2-25
Granular Chemical Application Field Check	2-26
Water Tank	2-27

ROW UNIT OPERATION

Planting Depth	3-1
"V" Closing Wheel Adjustment (Rubber or Cast Iron)	3-1
Closing Wheel Shield (Rubber or Cast Iron "V" Closing Wheels)	3-2
Drag Closing Attachment	3-2
Seed Hoppers	3-3
Seed Meter Drive Release	3-3
Row Unit Extension Brackets	3-3
Row Unit Chain Routing	3-4
Quick Adjustable Down Force Springs Option	3-5
Brush-Type Seed Meter	3-6
Finger Pickup Seed Meter	3-7
Vacuum Settings	3-8
Rapeseed Planting Section	3-13
Vacuum Meter Insulation For Rapeseed Planting	3-15
Spiked Closing Wheel	3-17
Row Unit Mounted Residue Wheel	3-18
Row Unit Mounted No Till Coulter	3-19
Coulter Mounted Residue Wheels	3-19
Granular Chemical Hopper and Drive	3-20
Granular Chemical Banding Options	3-21
Granular Chemical Bander Shield	3-21

FERTILIZER

Double Disc Fertilizer Opener	4-1
Notched Single Disc Openers	4-2
Residue Wheel Attachment for Notched Single Disc Fertilizer Opener	4-4
Depth/Gauge Wheel Attachment for Notched Single Disc Fertilizer Opener	4-4
HD Single Disc Fertilizer Opener	4-5
Liquid Fertilizer Attachment	4-7

RATE CHARTS 5-1**LUBRICATION AND MAINTENANCE**

Lubrication	6-1
Sealed Bearings	6-1
Wrap Spring Wrench Assembly	6-1
Drive Chains	6-2
Bushings	6-3
Wheel Bearings	6-4
Grease Fittings	6-4
Liquid Fertilizer	6-7
Liquid Fertilizer Piston Pump Crankcase Oil Level	6-7
Fertilizer Check Valve Cleaning and Repair	6-7

PTO pump shaft and Tractor pto shaft	6-8	Point Row Clutch Troubleshooting	7-4
Mounting Bolts and Hardware	6-10	Seed Meter (Finger Pickup) Troubleshooting	7-5
Tire Pressure	6-12	Seed Meter (Brush-Type) Troubleshooting	7-6
Chain Tension Adjustment	6-12		
Finger Pickup Seed Meter Inspection/Adjustment	6-13		
Cleaning Finger Pickup Seed Meter For Storage	6-14		
Brush-Type Seed Meter Maintenance	6-15		
Cleaning Brush-Type Seed Meter For Storage	6-16		
Vacuum Seed Meter Maintenance	6-17		
Seed Meter Cleanout	6-17		
Drag Closing Attachment	6-19		
Gauge Wheel Adjustment	6-19		
Gauge Wheel Arm Bushing/Seal Replacement	6-20		
Gauge Wheel Arm Pivot Spindle Replacement	6-21		
15" Seed Opener Disc Blade/Bearing Assembly	6-22		
Seed Tube Guard/Inner Scraper	6-24		
Granular Chemical Attachment	6-24		
Row Unit Mounted Residue Wheel	6-25		
Row Unit Mounted No Till Coulter	6-25		
Coulter Mounted Residue Wheels	6-25		
Row Marker Sequencing/Flow Control Valve Inspection	6-26		
Row Marker Bearing Lubrication or Replacement	6-27		
Wheel Bearing Repack or Replacement	6-28		
Point Row Clutch Maintenance	6-29		
Piston Pump Storage	6-31		
Preparing Planter for Storage	6-31		
Electrical Wiring Diagram for Lighting Package	6-32		
Electrical Wiring Diagrams for Point Row Clutches	6-33		
Hydraulic Hose Life	6-34		
Hydraulic System Schematic - Planter Raising	6-35		
Hydraulic System Schematic - Planter Lowering	6-35		
Hydraulic System Schematic - Optional Hydraulic Wing Fold	6-36		
Electric Clutch Schematic	6-37		
ISOBUS CAN Jumper Cable	6-37		
ISOBUS Clutch Cable	6-38		
ISOBUS Implement Cable	6-39		
Section Adapter Cable	6-39		
Product Control Module Cable	6-40		
Implement Switch Extension Cable	6-41		

TROUBLESHOOTING





Closing Wheel Troubleshooting	7-1
Piston Pump Troubleshooting	7-1
Lift Circuit Operation Troubleshooting	7-2
Row Marker Operation Troubleshooting	7-3

Kinze Manufacturing, Inc. thanks you for your patronage. We appreciate your confidence in Kinze farm machinery. Your Kinze planter has been carefully designed to provide dependable operation in return for your investment.

This manual has been prepared to aid you in the operation and maintenance of the planter. It should be considered a permanent part of the machine and remain with the machine when you sell it.

It is the responsibility of the user to read and understand the Operator Manual in regards to safety, operation, lubrication and maintenance before operation of this equipment. It is the user's responsibility to inspect and service the machine routinely as directed in the Operator Manual. We have attempted to cover all areas of safety, operation, lubrication and maintenance; however, there may be times when special care must be taken to fit your conditions.

Throughout this manual the symbol  and the words **DANGER**, **WARNING**, and **CAUTION** are used to call attention to safety information that if not followed, will or could result in death or injury. **NOTICE** and **NOTE** are used to call your attention to important information. The definition of each of these terms follows:

	Indicates an imminently hazardous situation that, if not avoided, will result in death or serious injury. This signal word is to be limited to the most extreme situations, typically for machine components which, for functional purposes, cannot be guarded.
	Indicates a potentially hazardous situation that, if not avoided, could result in death or serious injury, and includes hazards that are exposed when guards are removed. It may also be used to alert against unsafe practices.
	Indicates a potentially hazardous situation that, if not avoided, may result in minor or moderate injury. It may also be used to alert against unsafe practices.
	Used to address safety practices not related to personal injury.

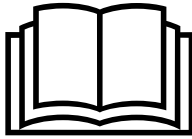

Improperly operating or working on this equipment could result in death or serious injury. Read and follow all instructions in Operator Manual before operating or working on this equipment.



Some photos in this manual may show safety covers, shields, or lockup devices removed for visual clarity. **NEVER OPERATOR OR WORK ON** machine without all safety covers, shields, and lockup device in place as required.

NOTE: Some photos in this manual may have been taken of prototype machines. Production machines may vary in appearance.

NOTE: Some photos and illustrations in this manual show optional attachments installed. Contact your Kinze Dealer for purchase of optional attachments.

The Kinze Limited Warranty for your new machine is stated on the retail purchaser's copy of the Warranty And Delivery Receipt form. Additional copies of the Limited Warranty can be obtained through your Kinze Dealer.

Warranty, within the warranty period, is provided as part of Kinze's support program for registered Kinze products which have been operated and maintained as described in this manual. Evidence of equipment abuse or modification beyond original factory specifications will void the warranty. Normal maintenance, service and repair is not covered by Kinze warranty.

To register your Kinze product for warranty, a Warranty And Delivery Receipt form must be completed by the Kinze Dealer and signed by the retail purchaser, with copies to the Dealer, and to the retail purchaser. Registration must be completed and submitted to Kinze Manufacturing, Inc. within 5 business days of delivery of the Kinze product to the retail purchaser. Kinze Manufacturing, Inc. reserves the right to refuse warranty on serial numbered products which have not been properly registered.

If service or replacement of failed parts which are covered by the Limited Warranty are required, it is the user's responsibility to deliver the machine along with the retail purchaser's copy of the Warranty And Delivery Receipt to the Kinze Dealer for service. Kinze warranty does not include cost of travel time, mileage, hauling or labor. Any prior arrangement made between the Dealer and the retail purchaser in which the Dealer agrees to absorb all or part of this expense should be considered a courtesy to the retail purchaser.

Kinze warranty does not include cost of travel time, mileage, hauling, or labor.

GENERAL INFORMATION

This manual covers all production years of the Model 3205 planter. Contact your Kinze dealer for additional options which may be available for your specific model year planter.

Information in this manual was current at time of printing. However, due to Kinze’s ongoing product improvement, production changes may cause your machine to appear slightly different in detail. Kinze Manufacturing, Inc. reserves the right to change specifications or design without notice and without incurring obligation to install the same on machines previously manufactured. To obtain the most recent version of your publication, please contact your Kinze dealer.

Right hand (R.H.) and left hand (L.H.), as used throughout this manual, are determined by facing in direction machine travels in use, unless otherwise stated.

TOOLS REQUIRED

Hardware Size / Tool Required			
$1/4" = 7/16"$	$7/16" = 5/8"$ (nut for $7/16"$ hardware uses $11/16"$ tool)	$3/4" = 1 1/8"$	$1 1/4" = 1 7/8"$
$5/16" = 1/2"$	$1/2" = 3/4"$	$7/8" = 1 5/16"$	$1 1/2" = 2 1/4"$
$3/8" = 9/16"$	$5/8" = 15/16"$	$1" = 1 1/2"$	

SPECIFICATIONS

Specification	
Number of Rows	12 Row 70 cm
Weight Empty (Mechanical)*	3402 kg - 3659 kg
*Base machine weights include planter frame including row markers, hydraulic cylinders, hoses, fittings, tires, wheels, drive and drill shafts, sprockets, chains and required drive components, parking jack, safety/warning lights, SMV sign, transport safety chain, and Kinze pull row units (closing wheel arms less closing wheels) with seed hopper, lid, and dual quick adjustable down force springs option.	
Axle Weight Empty**	3112 kg
Tongue Weight Empty**	1352 kg
**Weight is based off a typical configuration of a complete machine.	
Transport Height	2.77m
Transport Width	4.93m
Length	5.41m
Planting Width	8.23m
Seed Capacity	67L/Hopper (Mechanical)
Transport Tires	Six 7.50" x 20" 8 ply rib implement tires w/center groove - Inflate to 2.8 bar (40 PSI)
Contact Drive Tires	Two 4.10" x 6" spring-loaded contact drive tires. - Inflate to 3.5 bar (50 PSI)
Field Lift	Two Master/slave rephasing with two assist cylinders (six cylinders)
Row Markers	Three-fold low profile with 16" solid concave blade, cast iron hubs, and depth bands.

TRACTOR HYDRAULIC REQUIREMENTS







Configuration	Requirements		Description
Base machine with mechanical meters. Hydraulic fold.	2 SCV	57 L/min	#1 SCV: Planter lift
			#2 SCV: Markers/fold (manual selector valve)
Base machine with vacuum meters. Hydraulic fold.	3 SCV	82 L/min	#1 SCV: Planter lift
			#2 SCV: Markers/fold (manual selector valve)
			#3 SCV: Vacuum Fan
Base machine with vacuum meters and tractor mounted PTO pump. Hydraulic fold.	2 SCV	57 L/min	#1 SCV: Planter lift
			#2 SCV: Markers/fold (manual selector valve)

MINIMAL TRACTOR HORSEPOWER REQUIREMENTS

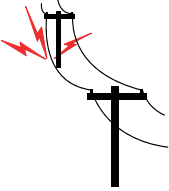
Configuration	Requirements	Description
12 Row 70CM	120 ¹ HP	Base machine, w/o fertilizer
¹ Options, such as Liquid or Dry Fertilizer, as well as planting speed and terrain can increase given requirements significantly.		

1. Read and understand instructions provided in this manual and warning labels. Review these instructions frequently!
 2. This machine is designed and built with your safety in mind. Do not make any alterations or changes to this machine. Any alteration to design or construction may create safety hazards.
 3. A large portion of farm accidents happen from fatigue or carelessness. Safe and careful operation of tractor and planter will help prevent accidents.
 4. Never allow planter to be operated by anyone unfamiliar with operation of all functions of the unit. Operators must read and thoroughly understand all instructions given in this manual before operating or working on equipment.
 5. Be aware of bystanders, particularly children! Always look around to make sure it is safe to start tow vehicle engine or move planter. This is particularly important with higher noise levels and quiet cabs, as you may not hear people shouting.
 6. Make sure planter weight does not exceed towing capacity of tractor, or bridge and road limits. This is critical to maintain safe control and prevent death or injury, or property and equipment damage.
 7. Never ride or allow others to ride on planter.
 8. Store planter in an area away from human activity. DO NOT permit children to play on or around the stored unit.
 9. Keep hands, feet, and clothing away from moving parts. Do not wear loose-fitting clothing which may catch in moving parts.
 10. Always wear protective clothing, shoes, gloves, hearing, and eye protection applicable for the situation.
 11. Do not allow anyone to stand between tongue or hitch and towing vehicle when backing up to planter.
 13. Prevent electrocution, other injuries, or property and equipment damage. Watch for obstructions such as wires, tree limbs, etc. when operating machine. Be aware of clearances during turns and when folding/unfolding planter.
 14. Reinstall all guards removed for maintenance activities. Never leave guards off during operation.
 15. Use of aftermarket hydraulic, electric, or PTO drives may create serious safety hazards to you and people nearby. If you install such drives, follow all appropriate safety standards and practices to protect you and others near this planter from injury.
 16. Follow all federal, state/provincial, and local regulations when towing farm equipment on a public highway. Use safety chain (not an elastic or nylon/plastic tow strap) to retain connection between towing and towed machines in the event of primary attaching system separation.
 17. Make sure all safety/warning lights, SMV sign, and reflective decals are in place and working properly before transporting the machine on public roads.
 18. Limit towing speed to 25 km/h. Tow only with farm tractor of a minimum 90 HP. Allow for unit length when making turns.
 19. Reduce speed prior to turns to avoid the risk of overturning. Always drive at a safe speed relative to local conditions and ensure your speed is slow enough for a safe emergency stop.
 20. Chemical application is often an integral part of planting. Follow label instructions for proper chemical mixing, handling and container disposal methods.
 21. Be familiar with safety procedures for immediate first aid should you accidentally contact chemical substances.
 22. Use the proper protective clothing and safety equipment when handling chemicals.
 23. Chemicals are supplied with Material Safety Data Sheets (MSDS) that provide full information about the chemical, its effects on exposure, and first aid needs in the event of an emergency. Keep your MSDS file up-to-date and available for first responders in case of emergency.
 24. When servicing ground engaging components such as opening disks and firming points, use special care to avoid points and edges worn sharp during use.
 25. Use professional help if you are unfamiliar with working on hydraulic systems. Pressurized hydraulic fluid can penetrate body tissue and result in death, serious infection, or other injuries.
- Never pour waste onto the ground, down a drain, or into any water source.
- When disposing of waste such as oil, use leakproof containers. Be sure to use containers that do not resemble food or beverage which may mislead someone into consuming them. Dispose of oil per your local, regional requirements.
- When disposing of any fertilizer chemicals used, contact the supplier of the chemicals.
- Model 3205 planter consists of 85% recyclable metals, 10% recyclable plastic and rubber, and 5% waste.

Following are some common hazard warnings associated with this equipment. Pay close attention to all safety, operating, and maintenance information in this manual and decals applied to your equipment.

 <p>DANGER</p> 	<p>Contacting or coming close to power lines or other high energy sources will cause death or serious injury.</p> <p>Keep away from power lines or high energy sources at all times.</p>
 <p>WARNING</p> 	<p>Improperly operating or working on this equipment could result in death or serious injury. Read and follow all instructions in Operator Manual before operating or working on this equipment.</p>
 <p>WARNING</p> 	<p>Falling equipment can cause death or serious injury. Install all lockup devices or lower planter to ground before working on equipment.</p>
 <p>WARNING</p> 	<p>Explosive separation of rim and tire parts can cause death or serious injury. Overinflation, rim and tire servicing, improper use of rims and tires, or worn or improperly maintained tires could result in a tire explosion.</p>

SAFETY SIGNS AND DECALS

	<p>All safety/warning lights, reflective decals, and SMV sign must be in place and visible before transporting machine on public roads or death, serious injury, and damage to property and equipment may result. Check federal, state/provincial, and local regulations before transporting equipment on public roads.</p>
---	---





Safety signs and decals are placed on the machine to warn of hazards and provide important operating and maintenance instructions. Information on these signs are for your personal safety and the safety of those around you. FOLLOW ALL SAFETY INSTRUCTIONS!

- Keep signs clean so they can be easily seen. Wash with soap and water or cleaning solution as required.
- Replace safety signs if damaged, painted over, or missing.
- Check reflective decals and SMV sign periodically. Replace if they show any loss of reflective properties.
- When replacing decals, clean machine surface thoroughly with soap and water or cleaning solution to remove all dirt and grease.



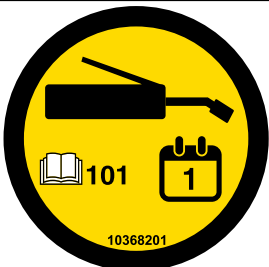

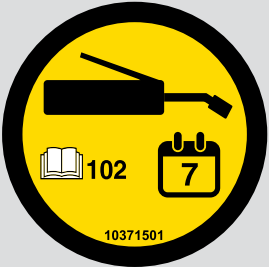
NOTE: Safety sign and decal locations are shown in the Parts Manual for this machine.

NOTE: Style and locations of SMV sign, reflective decals, and safety/warning lights conform to ANSI/ASABE S279.14 JUL 2008 and ANSI/ASABE S276.6 JAN 2005.



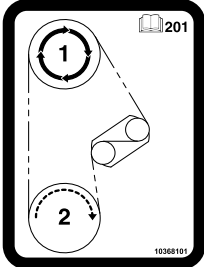
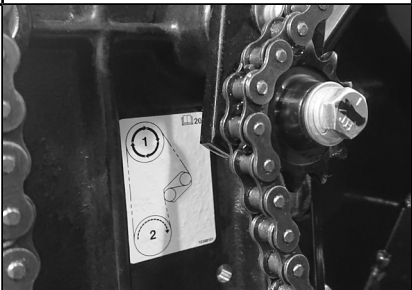
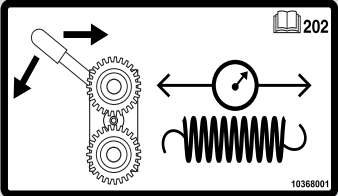
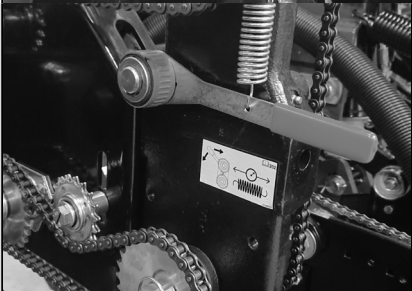
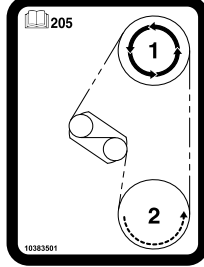
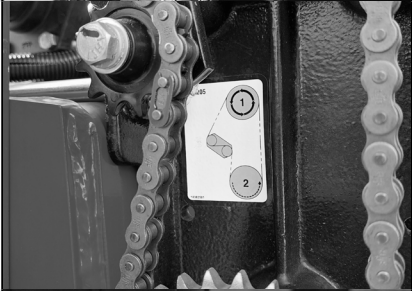



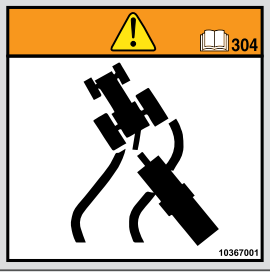
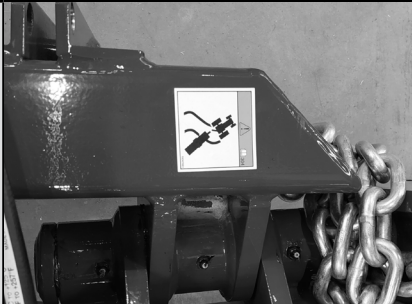

PICTORIAL DECALS

No.	Decal	Placement	Meaning
101			Oil/Grease daily.
102			Oil/Grease weekly.



PICTORIAL DECALS

No.	Decal	Placement	Meaning
201			<p>Upper sprocket is the drive sprocket. Lower sprocket is the driven sprocket.</p>
202			<p>Rotate knurled collar on wrap spring tightener to release spring tension.</p>
205			<p>Upper sprocket is the drive sprocket. Lower sprocket is the driven sprocket.</p>
213			<p>Water for emergency rinse.</p>
302			<p>Agricultural chemicals can cause death or serious injury to persons, animals, and plants or seriously damage soil, equipment, and property. Read and follow all chemical and equipment manufacturer labels and instructions.</p>

PICTORIAL DECALS

No.	Decal	Placement	Meaning
304			<p>Loss of control can cause death or serious injury, or damage to property and equipment. Tow only with farm tractor weight rated and configured for this equipment. Use safety chains and transport as specified in the Operator's and Parts Manuals.</p>
306			<p>Uncontrolled machine movement can crush resulting in death, serious injury, or damage to property and equipment.</p> <p>Install safety lockup devices before working under or transporting this equipment.</p>
308			<p>Improperly operating or working on this equipment could result in death or serious injury. Read and follow all instructions in Operator Manual before operating or working on this equipment.</p>
309			<p>Row marker can lower at any time and could cause death or serious injury.</p> <p>Stay away from row markers!</p> <p>Install safety lockup device when not in use.</p>
310			<p>Uncontrolled movement of planter components can cause death, serious injury, or damage to property and equipment.</p> <p>Raise planter and install cylinder lockups before folding. Fold on level ground. Install wing safety latches before towing.</p>

PICTORIAL DECALS

No.	Decal	Placement	Meaning
401			<p>Fan can start at any time. Operating fan can blow debris and has a high noise level.</p> <p>Always wear eye and hearing protection when working around fan.</p>

The following information is general in nature and was written to aid the operator in preparation of the tractor and planter for use, and to provide general operating procedures. The operator's experience, familiarity with the machine and the following information should combine for efficient planter operation and good working habits.

NOTICE	Always raise planter out of ground when making sharp turns or backing up or tractor and equipment may be damaged.
---------------	--

LIFT CYLINDER LOCKUPS

Install all lift cylinder lockups before transporting or working under or around planter.

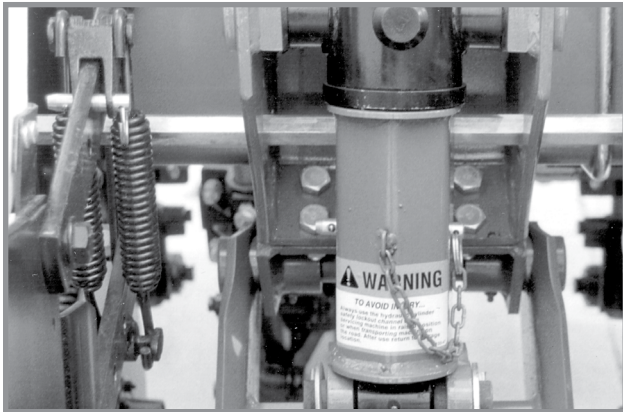

Lift cylinder lockup in transport position

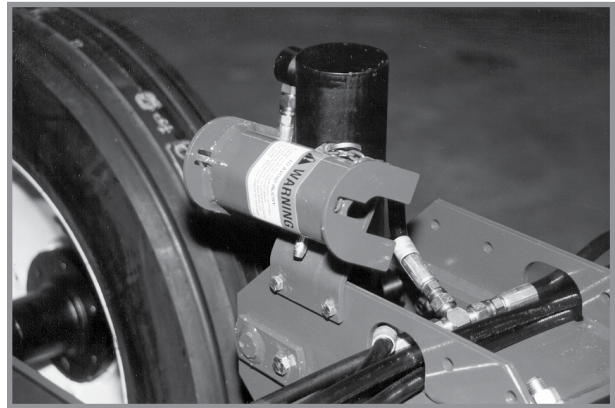

Lift cylinder lockup in storage position

WING SAFETY PINS

Secure wings with safety pins before transporting planter.

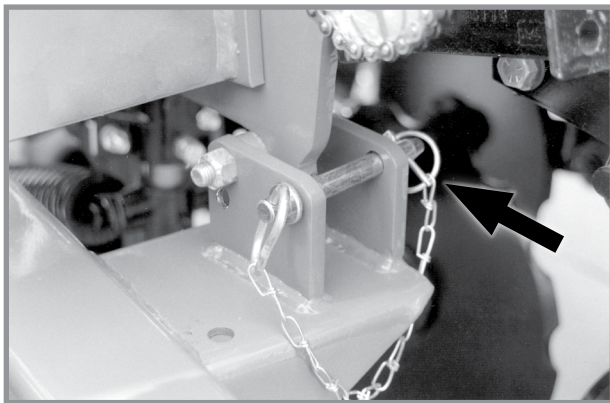

Wing safety pin in transport position

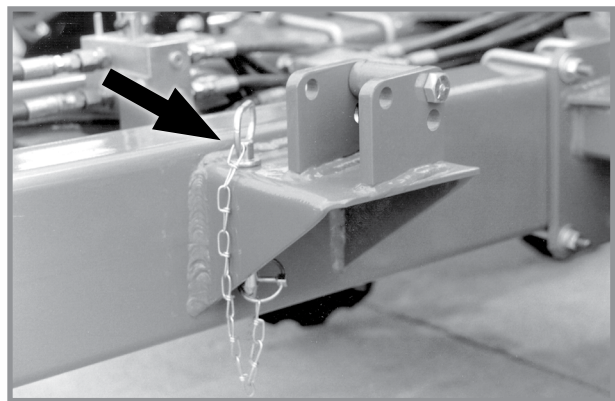

Wing safety pin in storage position

HYDRAULIC OPERATION

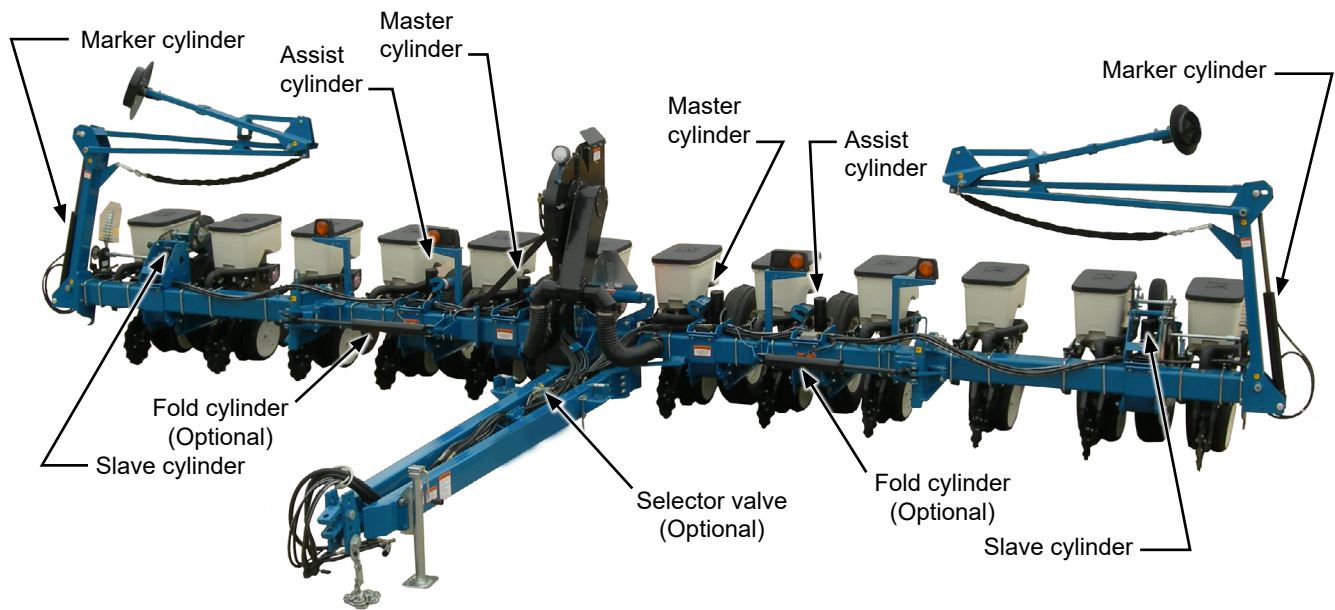

3205 Hydraulic component locations

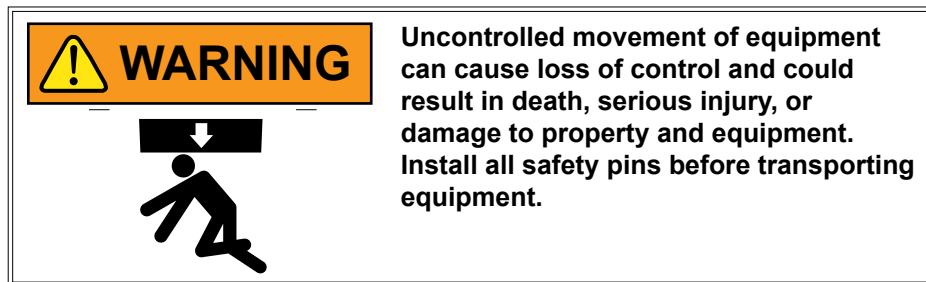

PLANTER LIFT SYSTEM

Planter lift system consists of six cylinders with one master, one slave, and one lift assist cylinder on each half of planter.

With this master/slave hydraulic lift system, oil is forced into base end of master and lift assist cylinders when tractor hydraulic lever is moved to raise position. As master cylinder is extended, oil from rod end of master cylinder is forced into base end of slave cylinder.

Displacement on master cylinder rod end is equal to displacement on slave cylinder base end which causes cylinders to move at same rate so planter raises and lowers evenly.

NOTE: Planter lift cylinders may get out of phase causing planter to lift unevenly. A valve located in each master and slave cylinder piston allows the lift system to be rephased when cylinders are cycled by lowering planter to ground and holding hydraulic lever for 10-30 seconds. Cycle system until the planter lifts and lowers evenly.

Assist cylinders aid in lifting and supporting the planter in a raised position. Planter will lift evenly and settle evenly if an assist cylinder is leaking (or if there is a leak in a hose or tractor connection).

ROW MARKERS

All Model 3205 planters are equipped with a dual valve hydraulic system which allows row markers to be operated independently of planter lift cylinders. Row markers are controlled on alternating sides through a tractor SCV. A sequencing valve directs flow to marker on opposite side each time a row marker is raised. When lower row marker is selected, row marker on opposite side of row marker last raised is lowered. Both row markers can also be down at the same time. Lower planter and row marker.

Marker hydraulic system includes two flow control valves. One flow control valve sets lowering speed and one sets raising speed of both markers.

OPTIONAL FOLD CYLINDERS WITH SELECTOR VALVE

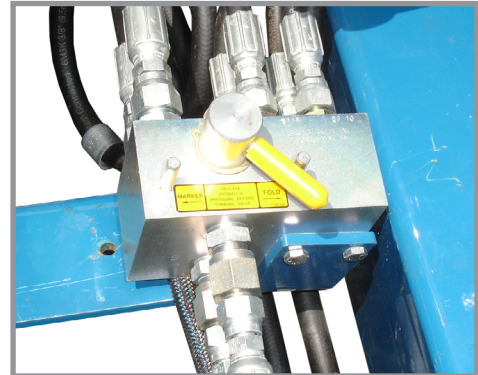

A hitch mounted, hand operated selector valve selects row marker or fold functions. Fold cylinders are mounted on the each side of front frame and folds wings to/from transport position. Row marker cylinders raise and lower row markers.

NOTE: Hydraulic pressure will prevent valve from moving. Release hydraulic pressure from system before attempting to move selector valve handle.







Selector valve

Following information is general in nature to aid in preparation of tractor and planter for use, and to provide general operating procedures. Operator experience, familiarity with the machine, and the following information should combine for efficient planter operation and good working habits.

 WARNING	<p>Improperly operating or working on this equipment could result in death or serious injury. Read and follow all instructions in Operator Manual before operating or working on this equipment.</p>
	

INITIAL PREPARATION

 WARNING	<p>Loose transport wheel lug bolts can result in wheel separation from planter and cause death, serious injury, and damage to property and equipment. Torque transport wheel $\frac{5}{8}$"- 18 lug bolts to 244 Nm before operating planter for the first time and periodically after.</p>
	

 WARNING	<p>Explosive separation of rim and tire parts can cause death or serious injury. Overinflation, rim and tire servicing, improper use of rims and tires, or worn or improperly maintained tires could result in a tire explosion.</p>
	

1. Torque transport wheel $\frac{5}{8}$ "- 18 lug bolts to 125 ft-lb (170 Nm)
2. Inflate transport/ground drive tires to 2.8 bar (40 PSI).
3. Inflate contact drive tires to 3.5 bar (50 PSI).



TRACTOR REQUIREMENTS

NOTICE	All Hydraulic Requirements: Minimum Pressure 162 bar (2350 PSI); Maximum Pressure 207 bar (3000 PSI). Check tractor hydraulics to ensure that maximum pressure cannot be exceeded.
---------------	---

Consult your dealer for information on horsepower requirements and tractor compatibility. Requirements vary with planter options, tillage, and terrain.

A 12 volt DC electrical system is required to operate planter safety/warning lights, and optional pneumatic down pressure system or work lights.

Two dual remote hydraulic outlets (SCV) are required on all models.

TRACTOR PREPARATION AND HOOKUP

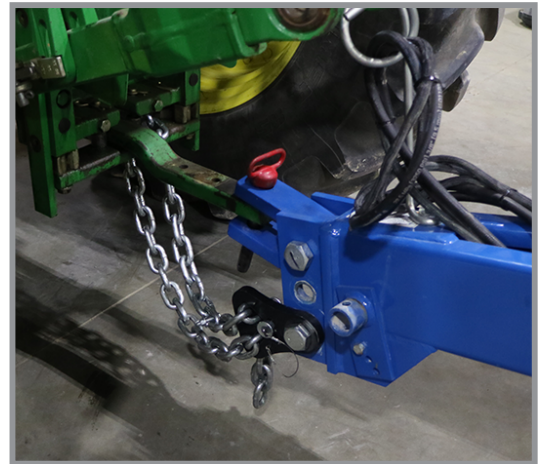

1. Adjust tractor drawbar 13 to 17 inches (33-43 cm) above ground. Adjust drawbar so hitch pin hole is directly below center line of PTO shaft. Make sure drawbar is in a stationary position.
2. Back tractor to planter and connect with a minimum 19mm (¾") diameter hitch pin. Secure with a locking or cotter pin.



Drawbar and safety chain connection

NOTE: DO NOT install safety chain using clevis mounting hardware. Safety chain MUST be installed separately.

3. Safety chain must be used to keep planter and tractor connected in case of a hitch pin/drawbar failure. Attach safety chain at an unused clevis mounting hole on the planter hitch. Torque hardware to 1140 Nm.

 WARNING	Pressurized hydraulic fluid can penetrate body tissue and result in death, serious infection, or other injuries. Fluid injected under skin must be IMMEDIATELY removed by a surgeon familiar with this type of injury. Make sure connections are tight and hoses and fittings are not damaged before applying system pressure. Leaks can be invisible. Keep away from suspected leaks. Relieve pressure before searching for leaks or performing any system maintenance.
	

NOTICE	Wipe hose ends to remove any dirt before connecting couplers to tractor ports or contamination may cause equipment failure.
---------------	--

4. Connect hydraulic hoses to tractor ports in a sequence familiar and comfortable to the operator.

NOTE: If tractor is equipped with an adjustable flow outlet (SCV), set to full flow position. For tractors not equipped with a method for finite adjustment of hydraulic flow, Flow Control Needle Valve Kit G1K426 is available from Kinze Repair Parts through your Kinze Dealer.

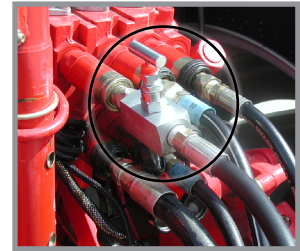

G1K426 needle valve kit

5. Connect ASABE Standards 7 terminal connector for safety/warning lights on planter to ASABE Standards receptacle on tractor. If your tractor is not equipped with an ASABE Standards receptacle, check with your tractor manufacturer for availability. Check warning lights on planter work in conjunction with warning lights on tractor.

6. Raise jack stand and remount horizontally on storage bracket.

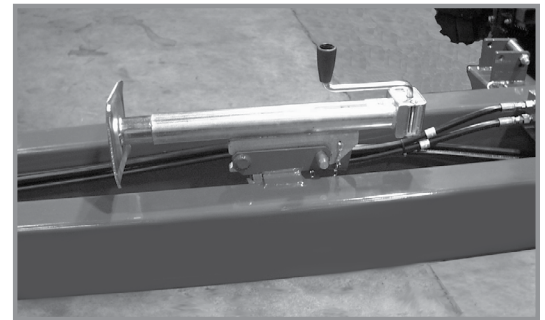

Jack stand in stored position

LEVEL PLANTER

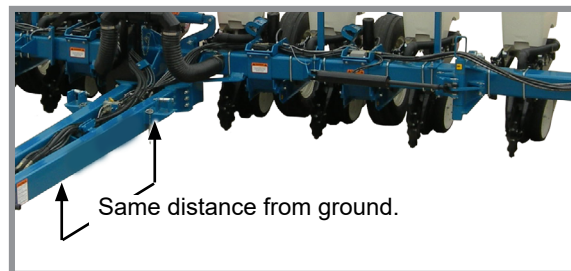

Level planter

Lateral adjustment is maintained by tire pressure. Check tires are inflated to specification. Front and rear level adjustment is maintained by hitch clevis position unless tractor drawbar is adjustable for height. Planter frame and row unit parallel arms must be level for proper planter and row unit operation. Bottom of toolbar should be 51 to 57 cm from planting surface.

1. Lower planter to planting position and check planter is level front to rear. Go to step 2 if hitch is too high or low.

NOTE: DO NOT install safety chain using clevis hardware. Move safety chain location if necessary.

2. Remove clevis hitch hex head cap screw and lock nut using a torque wrench. Replace if off-torque is below 102 Nm or there is corrosion or damage.

NOTE: Clevis must be free to move on hitch. DO NOT OVERTIGHTEN hardware.

3. Align clevis to hitch holes at new location and install hex head cap screw and lock nut. Tighten lock nut until threads are fully engaged and hex head cap screw and lock nut are firmly against hitch bracket.
4. Recheck with planter in field.

CYLINDER INFORMATION

	Assist Cylinder	Row Marker Cylinder	Hydraulic Wing Fold Cylinder	Slave Lift Cylinder	Master Lift Cylinder
Intended Use	Double acting applications	Double acting applications	Double acting applications	Double Acting Applications	Double Acting Applications
Piston	Ductile iron	Ductile iron	Ductile iron	Ductile Iron	Ductile Iron
Gland	Ductile iron	Ductile iron	Ductile iron	Ductile Iron	Ductile Iron
Tube	ST 52 Dom	ST 52 Dom	ST 52 Dom	ST 52 DOM Tubing	ST 52 DOM Tubing
Rod	1045 Nitro rod	1045 Nitro rod	1045 Nitro rod	1045 Nitro Rod	1045 Nitro Rod
End Mounts	Trunnion	Sleeve	Tang	Sleeve Trunnion Mount	Sleeve Trunnion Mount
Tube Seal	O-ring with polytemp back-up	Buna O-Ring with polytemp back-up	Buna O-Ring with polytemp back-up	Buna O-Ring with Polytemp Back-up	Buna O-Ring with Polytemp Back-up
Rod Seal	Polyester alloy u-cup	Polyester alloy u-cup	Polyester alloy u-cup	Polyester Alloy U-cup	Polyester Alloy U-cup
Rod Wiper	Polyester alloy snap in	Polyester alloy snap in	Polyester alloy snap in	Polyester Alloy Snap In	Polyester Alloy Snap In
Piston Seal	T-seal HNBR	T-seal HNBR	T-seal HNBR	T-Seal HNBR	T-Seal HNBR
Specifications					
Product Category	Hydraulic Cylinder	Hydraulic Cylinder	Hydraulic Cylinder	Hydraulic Cylinder	Hydraulic Cylinder
Maximum Stroke	203 mm	510 mm	406 mm	203 mm	203 mm
Working Pressure	209 bar (3000 PSI)	209 bar (3000 PSI)	209 bar (3000 PSI)	162-209 bar (2350-3000 PSI)	162-209 bar (2350-3000 PSI)
Bore Size	76 mm	63 mm	76 mm	83 mm	89 mm
Shaft Diameter	32 mm	32 mm	32 mm	32 mm	32 mm
Cylinder Configuration	Simple	Simple	Simple	Simple	Simple
Cylinder Action	Double	Double	Double	Double	Double
Material	Steel, Ductile Iron	Steel, Ductile Iron	Steel, Ductile Iron	Steel, Ductile Iron	Steel, Ductile Iron
Mounting Method	Trunnion	Sleeve	Tang	Sleeve Trunnion Mount	Sleeve Trunnion Mount
Mount Location	Barrel	End Cap	End Cap	End Cap	End Cap
Cylinder Style	Welded	Welded	Welded	Welded	Welded

HYDRAULIC HOSE INFORMATION

Part Number	A1000	A3114	A1020	A3202	A12010	A12009
Description	Hose Assembly, 3/8" x 3.8m	Hose Assembly, 3/8" x 39.0m	Hose Assembly, 3/8" x 12.0m	Hose Assembly, 3/8" x 43.0m	Hose Assembly, 3/8" x 65.8m	Hose Assembly, 3/8" x 62.0m
Product Category	Hydraulic Hose	Hydraulic Hose	Hydraulic Hose	Hydraulic Hose	Hydraulic Hose	Hydraulic Hose
Product Form	Hose; Assembly	Hose; Assembly	Hose; Assembly	Hose; Assembly	Hose; Assembly	Hose; Assembly
I.D.	9.5 mm	9.5 mm	9.5 mm	9.5 mm	9.5 mm	9.5 mm
O.D.	16.0 mm	16.0 mm	16.0 mm	16.0 mm	16.0 mm	16.0 mm
Minimum Bend Radius	51 mm	51 mm	51 mm	51 mm	51 mm	51 mm
Working Pressure	224 bar (3250 PSI)	224 bar (3250 PSI)	224 bar (3250 PSI)	224 bar (3250 PSI)	224 bar (3250 PSI)	224 bar (3250 PSI)
Temperature Range	-40°F - +212°F (-40°C - +100°C)	-40°F - +212°F (-40°C - +100°C)	-40°F - +212°F (-40°C - +100°C)	-40°F - +212°F (-40°C - +100°C)	-40°F - +212°F (-40°C - +100°C)	-40°F - +212°F (-40°C - +100°C)
Material	Modified Nitrile Type C2	Modified Nitrile Type C2	Modified Nitrile Type C2	Modified Nitrile Type C2	Modified Nitrile Type C2	Modified Nitrile Type C2
Specialized Construction	High tensile steel wire	High tensile steel wire	High tensile steel wire	High tensile steel wire	High tensile steel wire	High tensile steel wire
Media	Hydraulic Fluid	Hydraulic Fluid	Hydraulic Fluid	Hydraulic Fluid	Hydraulic Fluid	Hydraulic Fluid
Application	Agricultural; Construction	Agricultural; Construction	Agricultural; Construction	Agricultural; Construction	Agricultural; Construction	Agricultural; Construction

Part Number	A3130	A1010	A3176
Description	Hose Assembly, 3/8" x 173"	Hose Assembly, 3/8" x 120"	Hose Assembly, 3/8" x 86"
Product Category	Hydraulic Hose	Hydraulic Hose	Hydraulic Hose
Product Form	Hose; Assembly	Hose; Assembly	Hose; Assembly
I.D.	9.5 mm	9.5 mm	9.5 mm
O.D.	16.0 mm	16.0 mm	16.0 mm
Minimum Bend Radius	51 mm	51 mm	51 mm
Working Pressure	224 bar (3250 PSI)	224 bar (3250 PSI)	224 bar (3250 PSI)
Temperature Range	-40°F - +212°F (-40°C - +100°C)	-40°F - +212°F (-40°C - +100°C)	-40°F - +212°F (-40°C - +100°C)
Material	Modified Nitrile Type C2	Modified Nitrile Type C2	Modified Nitrile Type C2
Specialized Construction	High tensile steel wire	High tensile steel wire	High tensile steel wire
Media	Hydraulic Fluid	Hydraulic Fluid	Hydraulic Fluid
Application	Agricultural; Construction	Agricultural; Construction	Agricultural; Construction

MANUAL WING FOLD TRANSPORT TO FIELD OPERATION



WARNING

Planter wings may swing suddenly and cause death or serious injury. Do not stand between wings and frame when folding or unfolding planter. Planter must be on a level surface in all directions.



SUMMARIZED TRANSPORT TO FIELD SEQUENCE

- With center lift cylinders retracted and lockups in place, remove wing lock pins and fold wings out.
- Swing wing locking eyebolts into place.
- Extend lift cylinders.
- Remove center section lift cylinder lockups.
- Lower planter.
- Tighten wing locking eyebolts.
- Release turnbuckle at center of planter.

NOTE: Read following information for detailed instructions.

NOTE: Use special wrench stored on inside of hitch for center turnbuckle and wing lock eyebolt hex nuts. Always return wrench to storage location after use.

1. With planter raised and cylinder lockups in place, remove wing lock pins at marker support and hitch. Fold wings out to operating position.

NOTE: If wing lift tires are not raised, with cylinder lockups in place on four center section lift cylinders, move tractor hydraulic control to lowering position until cylinders are fully retracted and wing tires are fully raised.

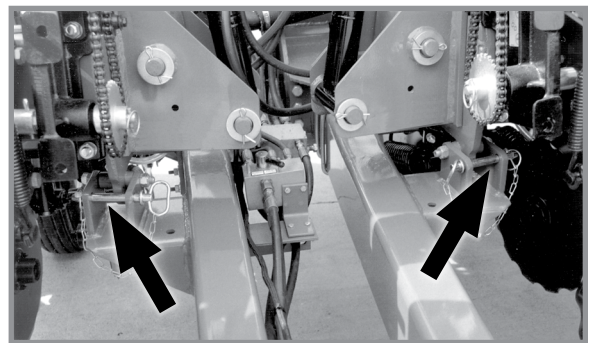

Wing lock pin locations

2. Swing wing locking eyebolts into position to lock each wing.
3. Operate hydraulic lever to extend lift cylinders. (Wing wheel cylinders may not fully extend.)
4. Remove cylinder lockups from four center section lift cylinders and place them in storage positions on wheel modules.
5. Lower planter. Hold tractor hydraulic control 5 to 10 seconds with cylinders fully retracted to rephase system.
6. Tighten wing lock 1 1/4" hex nuts.

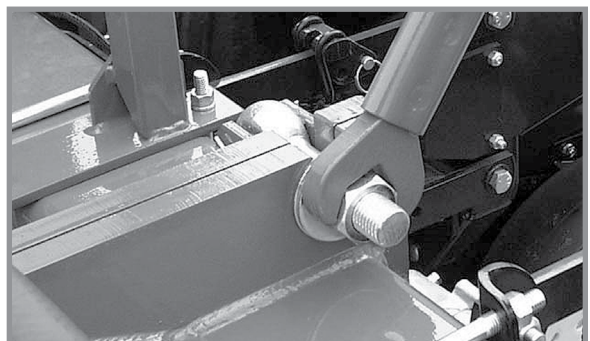

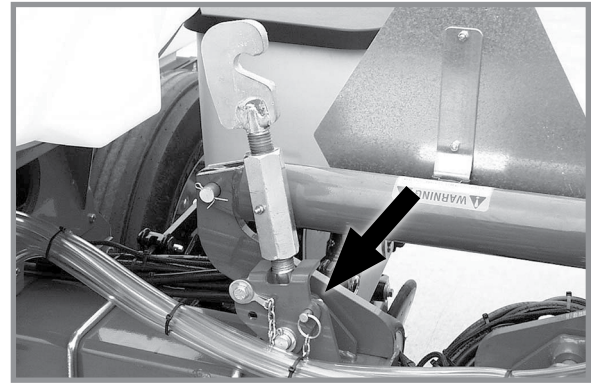

Securing wing lock eyebolt

7. Release center turnbuckle and raise upright. Secure in position with lockup pin.



Center turnbuckle lockup pin

MANUAL WING FOLD FIELD OPERATION TO TRANSPORT

 WARNING	<p>Planter wings may swing suddenly and cause death or serious injury. Do not stand between wings and frame when folding or unfolding planter. Planter must be on a level surface in all directions.</p>
	

SUMMARIZED FIELD TO TRANSPORT SEQUENCE

- Raise row markers and lower planter.
- Position turnbuckle to hold frame in level position.
- Loosen wing locking eyebolts and swing over to unlock wings.
- Raise planter.
- Install lockups on center lift cylinders.
- Retract wing lift cylinders.
- Fold wings forward and lock in place.

NOTE: Read following information for detailed instructions.

NOTE: Use special wrench stored on inside of hitch for center turnbuckle and wing lock eyebolt hex nuts. Always return wrench to storage location after use.

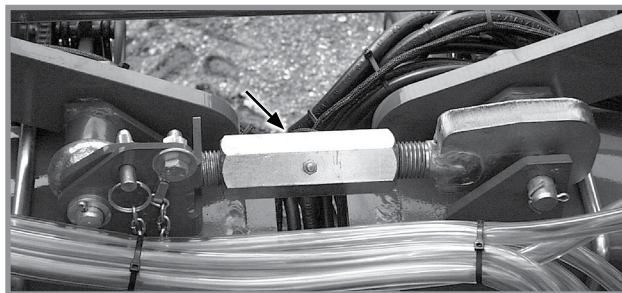

Center turnbuckle installation

1. Fold row markers to raised transport position and lower planter to ground.
2. Swing center turnbuckle into position to hold planter frame level and tighten slightly. Install lockup pin in storage location

3. Loosen wing lock 1 1/4" hex nuts and swing wing lock eyebolts over to release planter wings.
4. Raise planter.
5. Install cylinder lockups on four center section lift cylinders.
6. Place tractor hydraulic control in lowering position and hold until wing cylinders are fully retracted and wing tires are fully raised.

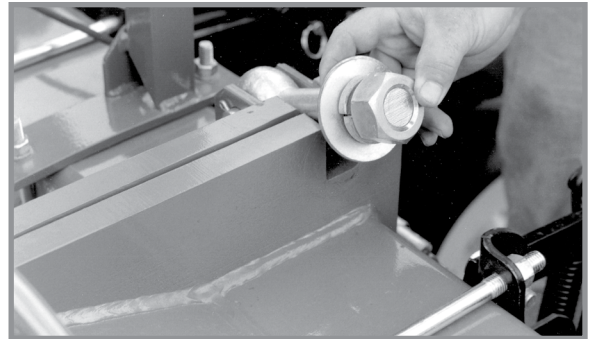

Wing lock eyebolt



Uncontrolled wing movement can cause death, serious injury, and damage to property and equipment. Make sure wings are properly locked in place before moving planter.

7. Fold each wing forward into transport position and lock wings in place at marker support and hitch with wing safety pins.

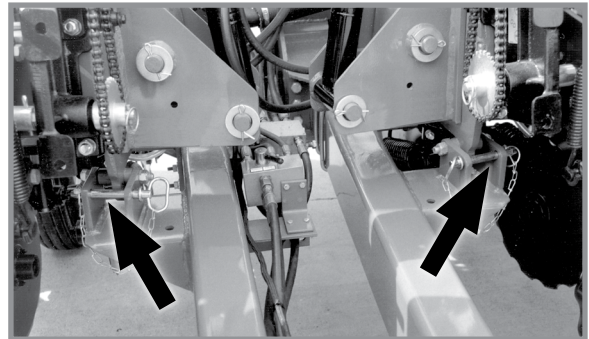

Wing lock pin locations

HYDRAULIC WING FOLD TRANSPORT TO FIELD OPERATION



Planter wings may swing suddenly and cause death or serious injury. Do not stand between wings and frame when folding or unfolding planter. Planter must be on a level surface in all directions.

SUMMARIZED TRANSPORT TO FIELD SEQUENCE

- With center lift cylinders retracted and lockups in place, remove wing lock pins.
- Move selector valve to "FOLD".
- Hydraulically fold wings out.
- Swing wing locking eyebolts into place.
- Extend lift cylinders.
- Remove center section lift cylinder lockups.
- Lower planter.
- Tighten wing locking eyebolts.
- Release turnbuckle at center of planter.
- Move selector valve to "MARKER".

NOTE: Read following information for detailed instructions.

NOTE: Use special wrench stored on inside of hitch for center turnbuckle and wing lock eyebolt hex nuts. Always return wrench to storage location after use.

1. With planter raised and cylinder lockups in place, remove wing lock pins at marker support and hitch. Fold wings out to operating position.

NOTE: If wing lift tires are not raised, with cylinder lockups in place on four center section lift cylinders, move tractor hydraulic control to lowering position until cylinders are fully retracted and wing tires are fully raised.

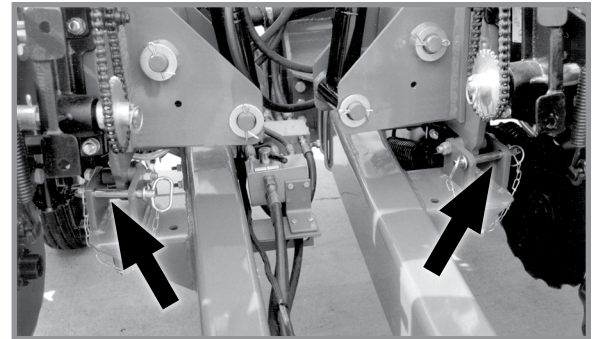

Wing lock pin locations

NOTE: Hydraulic pressure will prevent selector valve from moving. Release hydraulic pressure from system before attempting to move selector valve handle.

2. Move selector valve to "FOLD".
3. Move the tractor hydraulic control and fold the wings out to operating position.

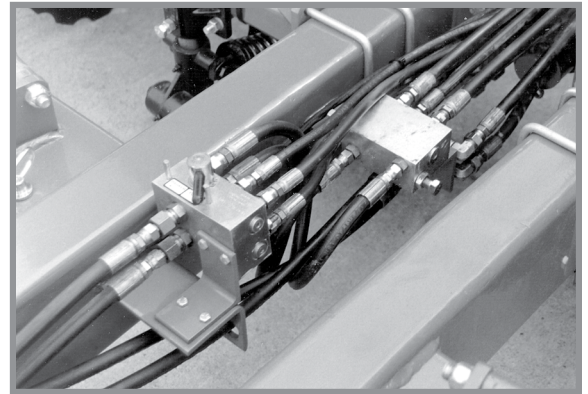

Selector valve

4. Swing wing lock eyebolts into position to lock each wing.
5. Operate the hydraulic lever to extend the lift cylinders. (Wing wheel cylinders may not fully extend)
6. Remove four center section cylinder lockups from cylinders and place them in wheel module storage positions.
7. Lower planter. Hold tractor hydraulic control 5 to 10 seconds with cylinders fully retracted to rephase system.
8. Tighten wing lock 1¼" hex nuts.

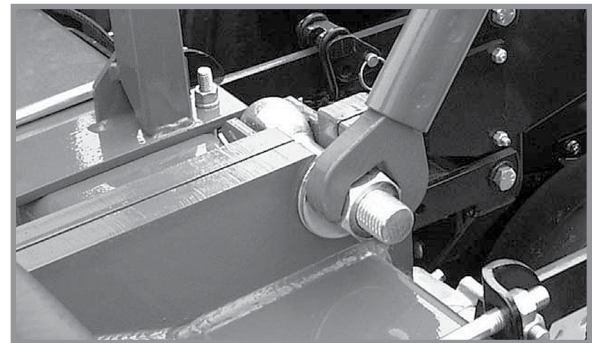

Securing wing lock eyebolt

9. Release center turnbuckle and raise upright. Secure in position with lockup pin.

NOTE: Hydraulic pressure will prevent selector valve from moving. Release hydraulic pressure from system before attempting to move selector valve handle.

10. Move selector valve to "MARKER".

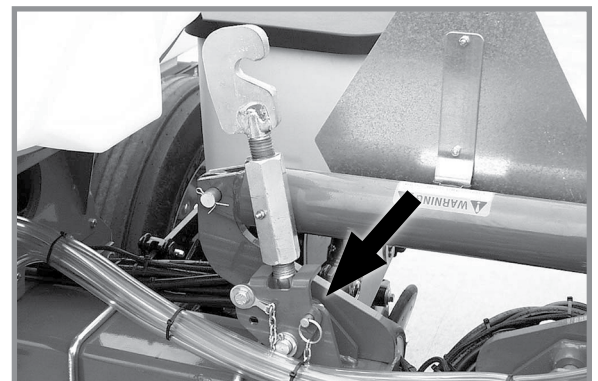

Center turnbuckle lockup pin

HYDRAULIC WING FOLD FIELD OPERATION TO TRANSPORT

WARNING



Planter wings may swing suddenly and cause death or serious injury. Do not stand between wings and frame when folding or unfolding planter. Planter must be on a level surface in all directions.

SUMMARIZED FIELD TO TRANSPORT SEQUENCE

- Raise row markers and lower planter.
- Position turnbuckle to hold frame in level position.
- Move selector valve to "FOLD".
- Loosen wing lock eyebolts and swing over to unlock wings.
- Raise planter.
- Install lockups on center lift cylinders.
- Retract wing lift cylinders.
- Hydraulically fold wings forward. Lock wings in place.
- Move selector valve to "MARKER".

NOTE: Read following information for detailed instructions.

NOTE: Use special wrench stored on inside of hitch for center turnbuckle and wing lock eyebolt hex nuts. Always return wrench to storage location after use.

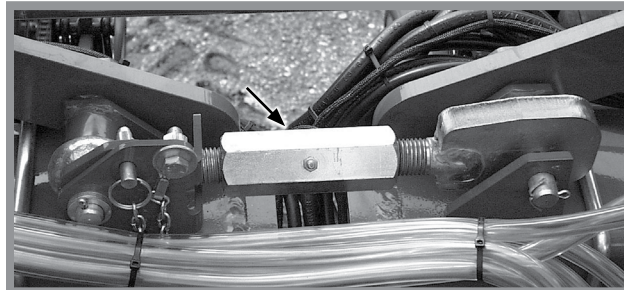

Center turnbuckle installation

1. Fold row markers to raised transport position and lower planter to ground.
2. Swing center turnbuckle into position to hold planter frame level and tighten slightly. Install lockup pin in storage location

NOTE: Hydraulic pressure will prevent selector valve from moving. Release hydraulic pressure from system before attempting to move selector valve handle.

3. Move selector valve to "FOLD".

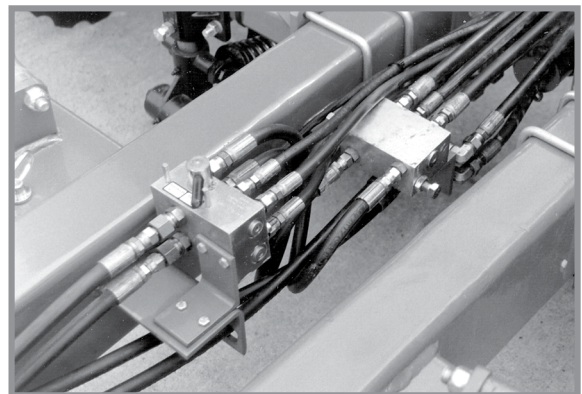

Selector valve

4. Loosen wing lock 1¼" hex nuts and swing wing lock eyebolts over to release planter wings.
5. Raise planter.
6. Install cylinder lockups on four center section lift cylinders.
7. Place tractor hydraulic control in lowering position and hold until wing cylinders are fully retracted and wing tires are fully raised.

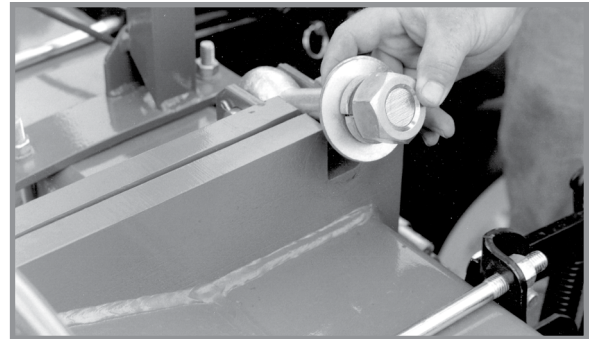

Wing lock eyebolt



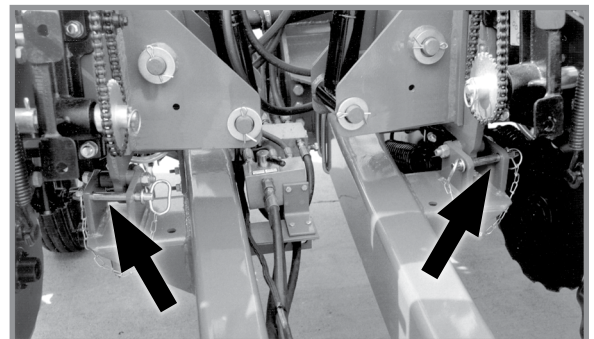

Uncontrolled wing movement can cause death, serious injury, and damage to property and equipment. Make sure wings are properly locked in place before moving planter.

8. Fold each wing forward into transport position and lock wings in place at marker support and hitch with wing safety pins.

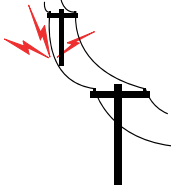

Wing lock pin locations

HYDRAULIC ROW MARKER OPERATION

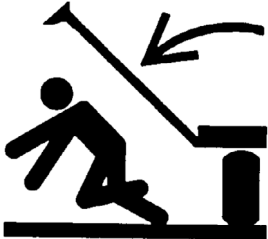
 DANGER	<p>Contacting or coming close to power lines or other high energy sources will cause death or serious injury.</p>
	<p>Keep away from power lines or high energy sources at all times.</p>
 WARNING	<p>Row marker can lower at any time and could cause death or serious injury. Stay away from row markers! Install safety lockup device when not in use.</p>
	

All Model 3205 planters are equipped with a dual valve hydraulic system. The dual valve system allows the row markers to be operated independently of the planter lift cylinders. Each time a marker is raised, the sequencing valve directs flow to lower the opposite marker.

Both markers can be used at the same time. Lower planter and selected marker. Move tractor control lever to raise position and immediately return it to lower position. This shifts the marker control valve and remaining marker will be lowered.

NOTE: A hand operated selector valve selects row marker or wing fold functions on machines with hydraulic wing fold option. Remove pressure from hydraulic system before attempting to move selector handle.

ROW MARKER SPEED ADJUSTMENT

NOTICE

Excessive row marker travel speed can damage row markers. Adjust flow controls before row markers are first used.

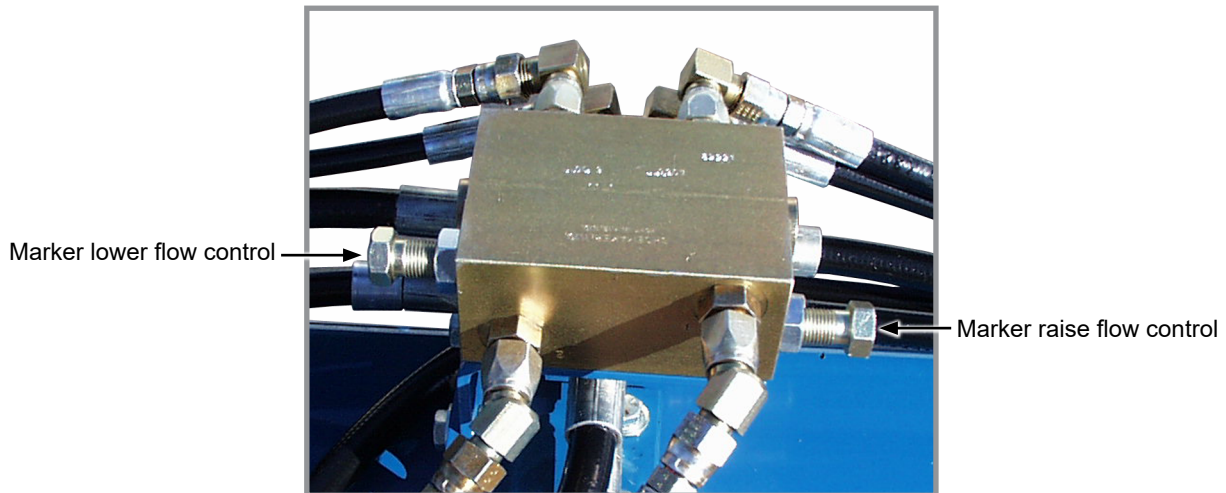

Row marker flow control valves

Two flow control valves determine amount of oil flow restriction controlling row marker travel speeds. One flow control valve controls lowering speed and one controls raising speed of both markers.

NOTE 1: Hydraulics operate slowly when oil is cold. Make all adjustments with oil warm.

NOTE 2: On a tractor where oil flow cannot be controlled, tractor flow rate may be greater than rate marker cylinder can accept. Hold tractor hydraulic control lever until cylinder reaches end of its stroke. This occurs most often on tractors with an open center hydraulic system.

NOTE 3: On tractors with a closed center hydraulic system, set hydraulic flow control so detent functions properly.

1. Loosen jam nut and turn control clockwise (IN) to slow speed or counterclockwise (OUT) to increase speed.
2. Tighten jam nut after adjustments are made.

ROW MARKER ADJUSTMENT

1. Multiply number of rows by average row spacing in centimeters to determine total planting width.

Row Marker Lengths	
12 Row 70 cm	8,40 m

2. Lower planter and row marker assembly to ground.
3. Measure from planter center line to a point where blade contacts ground.
4. Adjust row marker extension so distance from marker disc blade to center line of planter is equal to total planting width. Adjust right and left row marker assemblies equally and securely tighten clamping bolts.

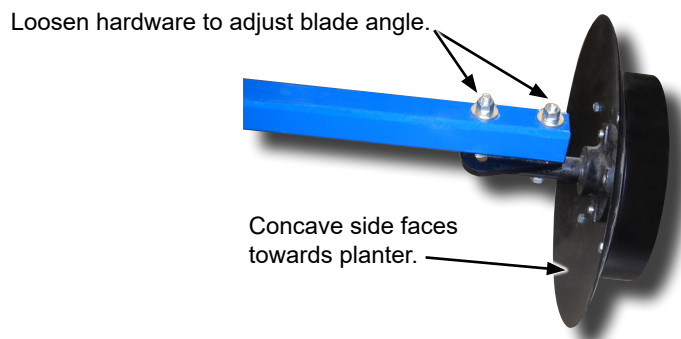

Row marker disc blade angle adjustment

NOTICE



Setting marker disc blade assembly at a sharper angle than needed adds stress to row marker assembly and shortens bearing and blade life. Set blade angle only as needed to leave a clear mark.

Marker disc blade is installed with concave side facing inward. Spindle assembly is slotted so hub and blade can be angled to throw more or less dirt.

5. Loosen hardware and move assembly as required.
6. Tighten bolts to specified torque.
7. Do a field test to ensure markers are properly adjusted.

NOTE: A notched marker blade is available from Kinze through your Kinze Dealer for use in more severe no till conditions.

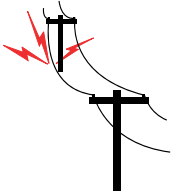
TRANSPORTING PLANTER

 DANGER	<p>Contacting or coming close to power lines or other high energy sources will cause death or serious injury.</p>
	<p>Keep away from power lines or high energy sources at all times.</p>
 WARNING	<p>All safety/warning lights, reflective decals, and SMV sign must be in place and visible before transporting machine on public roads or death, serious injury, and damage to property and equipment may result. Check federal, state/provincial, and local regulations before transporting equipment on public roads.</p>

- Tow only with farm tractor rated and configured for equipment.
- Know your route and be aware of any obstructions.
- Follow all road and bridge load limit restrictions.
- Never exceed maximum transport towing speed of 32 km/h.

CONTACT DRIVE SPRING ADJUSTMENT

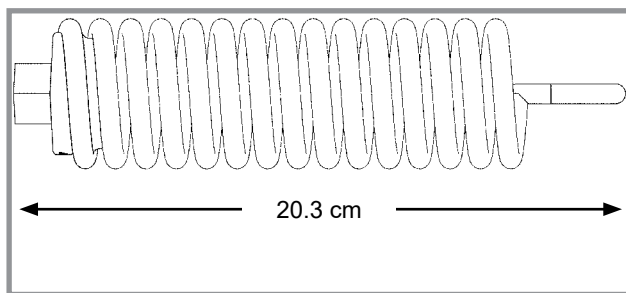

Spring length measurement (Factory setting)

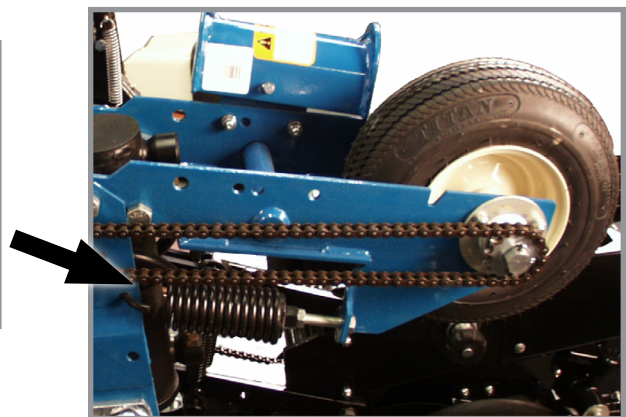

Down pressure spring location

There are two down pressure springs on each contact drive wheel. Spring tension is factory preset and normally requires no adjustment.

Basic setting for spring tension is approximately 90 kg of down force at tire contact point.

NOTE: Measurement must be taken in planting position with proper tire pressure.

WRAP SPRING WRENCH

Chain idlers use wrap spring wrenches to release and adjust transmission chain tension.

NOTE: Wrap spring wrenches are L.H. and R.H. specific. L.H. styles have silver metal or grey plastic release collars. R.H. styles have gold metal or blue plastic release collars.

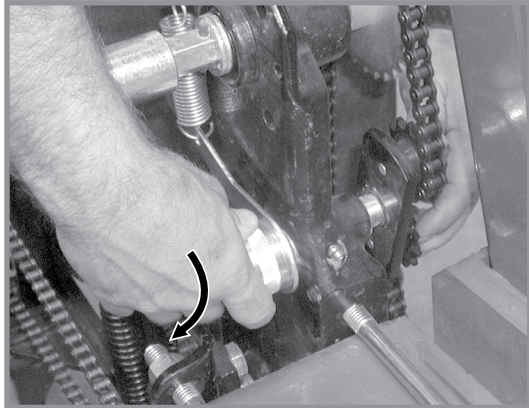

Release chain tension

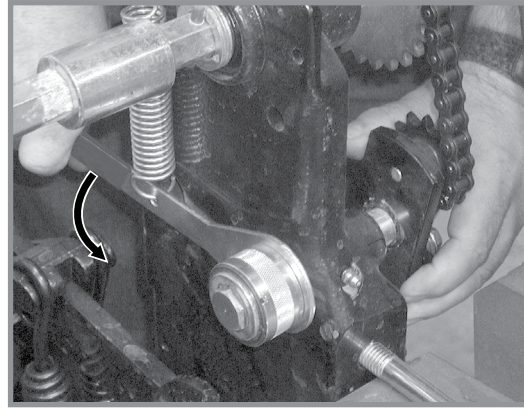

Increase chain tension

Rotate wrap spring wrench knurled collar while rotating chain idler away from chain to release chain tension.

Rotate chain idler into chain while rotating handle to tension idler spring.

CONTACT WHEEL DRIVE SPROCKETS

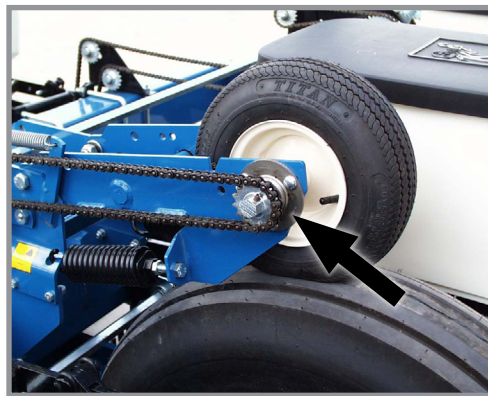

Contact wheel drive sprocket

NOTE: 15 tooth, 19 tooth or 30 tooth drive sprockets at each contact drive wheel can be interchanged from sprocket storage rod bolted to each transmission. 30 tooth sprockets require use of 124 pitch chains instead of standard 116 pitch No. 40 chains.

Chain tension is controlled by a spring-loaded sprocket idler. Amount of spring tension on chain is controlled by idler arm. Planting rate chart in Rate Chart section will aid you in selecting correct sprocket.

NOTE: 15, 19, and 30 tooth drive sprockets are NOT applicable to all rate charts. 23 tooth driven sprocket at reverser plate is changed to a 17 tooth sprocket when using 60 cell soybean seed disc. Check chart titles to ensure proper rate chart is selected.

NOTE: Make a field check after each sprocket combination adjustment to be sure you are planting at desired rate.

SEED RATE TRANSMISSION ADJUSTMENT

Seed rate transmissions allow simple, rapid changes of sprockets to obtain desired planting population. By removing lynch pins on hexagon shafts, sprockets can be interchanged with those from the sprocket storage rod bolted to the transmission.

Chain tension is controlled by a spring-loaded dual-sprocket idler. The idler assembly is equipped with an easy-release idler arm to remove spring tension for replacing sprockets.

Planting rate charts in Rate Chart section will aid you in selecting correct sprocket combinations.

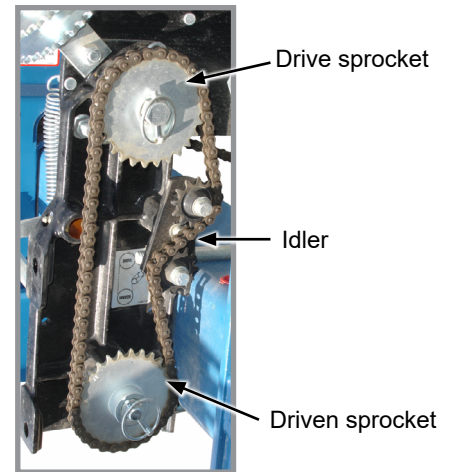

Seed rate transmission chain tension

STANDARD AND HALF RATE (2 TO 1) DRIVES

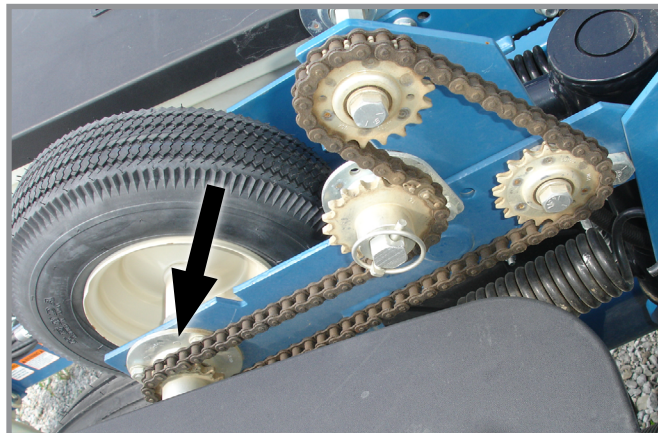

Rate drive

Seed planting rate charts are based on the standard rate drive using a 17 tooth sprocket unless otherwise specified.

NOTE: Half rate (2 to 1) drive is recommended only when desired population falls below that on planting rate charts.

Replacing standard 17 tooth drive sprocket located on inner side of top transmission shaft, with 34 tooth half rate (2 to 1) drive reduction sprocket reduces planter transmission speed and planting and application rates by approximately 50%.

NOTE: Do a field check after each sprocket combination adjustment to make sure you are planting at the desired rate.

SHEAR PROTECTION

Shear pins protect the planter driveline and row unit components from damage.

1. Determine where binding has occurred before replacing a pin. Turn shaft by hand (with the aid of a wrench) and check for misalignment and seized parts.
2. When shaft can be turned by hand (with the aid of a wrench) replace shear pins with same size and type. Spare shear pins are in wheel module storage area.

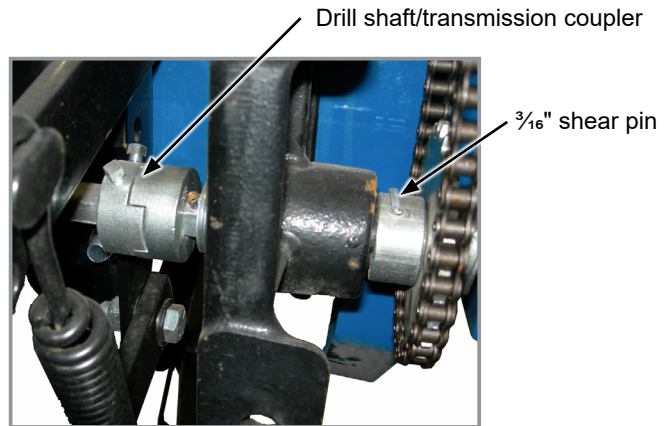

Transmission shaft and drill shaft coupler

NOTICE

Misaligned drill shaft/transmission coupler can cause equipment damage.

3. Check driveline alignment and follow prescribed lubrication schedules to prevent component binding or breakage.

TIRE SCRAPER

A tire scraper prevents buildup of dirt and mud between wheel arm assembly and tire.

Adjust scraper so it does not contact tire.



Tire scraper

RIDGE PLANTING

Planter toolbar height can be raised 8 cm for ridge planting.

Relocate 50 mm transport axles to lower hole in wheel arm.

Install axle here to raise bar height for ridge planting.

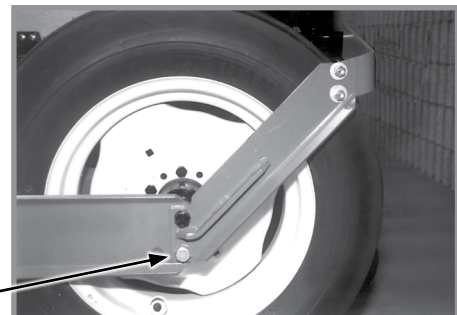

Ridge planting adjustment

POINT ROW CLUTCHES

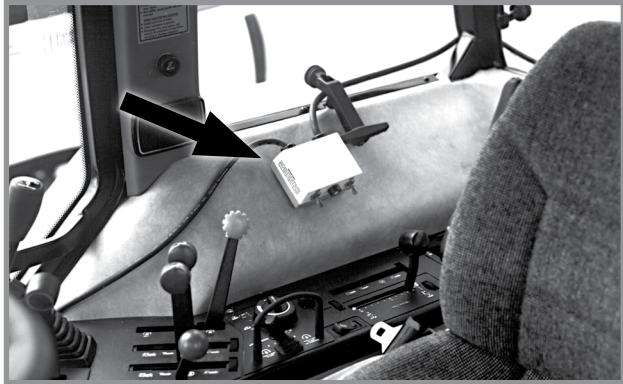

Point row clutch control box

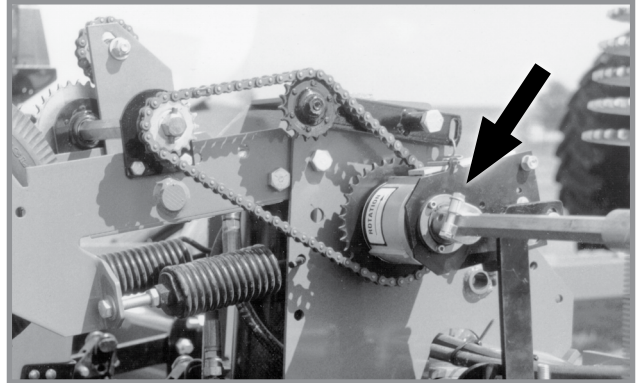

Point row clutch

Electric-activated clutches disengage drive on either half of planter for finishing up fields or for long point row situations. Clutch selector switch is located on tractor.

NOTICE

Switch must be **OFF** when planter is not in use or tractor battery will be drained.

NOTE: Liquid fertilizer piston pump has its own drive wheel and is not affected by point row clutch.

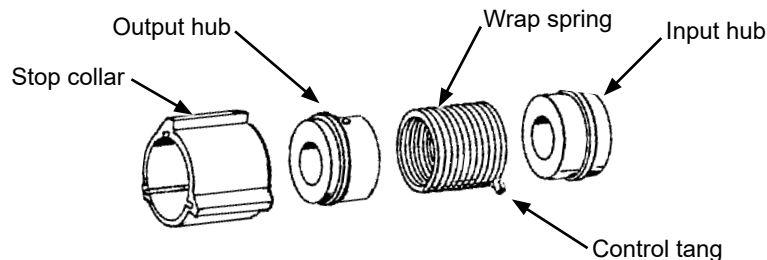

Clutch consists of a wrap spring riding on an input and output hub. Wrap spring is wrapped tightly over hubs during operation locking them together. Higher speeds create a tighter grip of spring on hubs.

Input end of spring is bent outward and is called the control tang. Control tang fits into a slot in stop collar located between input and output hubs over wrap spring. If stop collar is allowed to rotate with input hub, clutch is engaged. If stop collar is stopped from rotating, control tang connected to it is forced back and spring opens. This allows input hub to continue rotating without transmitting torque to output hub, stopping planter drive.

Stop collar is controlled by an electric solenoid and an actuator arm. When selector switch on tractor control box is OFF, solenoid coil is NOT ENERGIZED and actuator arm will not contact stop on stop collar, allowing it to rotate with hubs and drive planter.

When operational switch is in "DISENGAGE" (right or left) solenoid coil IS ENERGIZED and plunger in solenoid coil pulls actuator arm against stop on stop collar, disengaging wrap spring and stopping planter drive.

AG LEADER INTEGRA DISPLAY

INTEGRA is a full-featured hub of any precision farming operation. A large, full-color 12.1" HD touchscreen display is easy to read and offers powerful, year-round precision farming tools. Mapping, planter and application control, yield monitoring, real-time data logging, and more – are all controlled from the cab using the Integra display.

Four video camera inputs provide operators a better view of equipment operation and safety by allowing them to view live video on the display.

NOTE: See Integra operator manual for installation and programming.



Ag Leader Integra display

AG LEADER MONITORING CONTROL PACKAGE (PMM)

The PMM Magnetic Distance Sensor Package includes a planter-mounted module enclosure with cover and mounting hardware, seed tubes w/sensors, planter harness, planter monitor cable, shaft rotation sensors and magnetic distance sensor components.

Ag Leader Integra display and associated cab harnesses are also required.



Planter monitor module (PMM)

AG LEADER INCOMMAND 1200 DISPLAY

The InCommand 1200 is a full-featured display for any precision farming operation. A large, full-color 12.1" HD touchscreen display is easy to read and offers powerful, year-round precision farming tools. Mapping, planter and application control, yield monitoring, real-time data logging, and more – are all controlled from the cab using the InCommand display.

Four video camera inputs provide operators a better view of equipment operation and safety by allowing them to view live video on the display.

NOTE: See InCommand operator manual for installation and programming.



Ag Leader InCommand Display

AG LEADER ELECTRIC CLUTCHES

Electric clutches along with GPS can stop seed flow by turning off seed meters (and planter sections) based on field mapping and previously planted areas.

FIELD TEST

Perform a field test with any change of field and/or planting conditions, seed size or planter adjustment to ensure proper seed placement and operation of row units. See “Rate Charts”, “Checking Seed Population” and “Granular Chemical Application Field Check”.

- Check planter for front to rear and lateral level operation. See “Level Planter”.
- Check **all** row units to be certain they are running level. Row unit parallel arms should be approximately parallel to the ground when planting.
- Check row markers for proper operation and adjustment. See “Row Marker Adjustment” and “Row Marker Speed Adjustment”.
- Check for proper application rates and placement of granular chemicals on **all** rows. See “Granular Chemical Application Field Check”.
- Check for desired depth placement and seed population on **all** rows. See “Check Seed Population”.
- Check for proper application rates of fertilizer on **all** rows. See proper “Fertilizer Application Rate Chart”.

Reinspect machine after field testing.

- Hoses And Fittings
- Bolts And Nuts
- Cotter Pins And Spring Pins
- Drive Chain Alignment

CHECK SEED POPULATION

1. Tie up one or more sets of closing wheels by running a chain or rubber tarp strap between the hopper support panel and closing wheels. It may be necessary to decrease closing wheel arm spring tension.

Chain, rubber tarp strap, or similar.

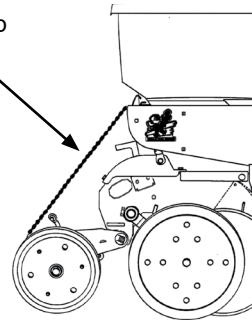

2. Plant a short distance and check to see if seed is visible in the seed trench. Adjust planting depth to a shallower setting if seed is not visible and recheck.

Planting depth adjustment handle

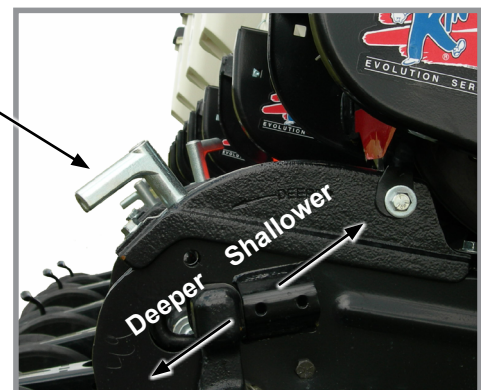

Planting depth adjustment

3. Measure $\frac{1}{1000}$ of an acre (hectare). See chart for correct distance for row width being planted. For example, if planting 70 cm rows $\frac{1}{1000}$ of an acre (hectare) would be 14.28m.

$\frac{1}{1000}$ Hectare Seed Population Count Row Width/Distance	
Row Width	70 cm
Distance	14.28 m

NOTE: Seeds may bounce or roll when planting with closing wheels raised and planting depth set shallow affecting seed spacing accuracy.

4. Count seeds in measured distance.
5. Multiply number of seeds placed in $\frac{1}{1000}$ of an hectare by 1000. This gives total population.

EXAMPLE: 70 cm row spacing 14.28 m equals $\frac{1}{1000}$ hectare.

26 seeds counted x 1000 = 26,000 seeds per hectare

Seed count can be affected by drive wheel and seed meter drive ratio, tire pressure, and/or seed meter malfunction.

1. If seed check shows average distance between seeds in inches is significantly different than seed rate chart indicates, first check drive ratio between drive wheel and seed meter. Check drive wheel air pressure, check for incorrect sprocket(s) in driveline and check drive and driven sprockets on transmission(s) for proper selection.
2. Check for seed meter malfunction. For example, if spacing between kernels of corn at the transmission setting being used is 20 cm and a gap of 40 cm is observed, a finger has lost its seed and not functioned properly. If two seeds are found within a short distance of each other, the finger has metered two seeds instead of one.
3. See “Finger Pickup Seed Meter Troubleshooting” and/or “Brush-Type Seed Meter Troubleshooting” in the Troubleshooting Section of this manual.

DETERMINING KILOGRAMS PER HECTARE (BRUSH-TYPE METER)

Seeds per hectare ÷ Seeds per kilogram (from label) = Kilograms per hectare

If seeds per kilogram information is not available use the following averages:

- 2,600 seeds per kilogram for medium size soybeans
- 15,000 seeds per kilogram for medium size milo/grain sorghum
- 4,500 seeds per kilogram for medium size cotton

DETERMINING LITERS PER HECTARE

Kilograms per hectare ÷ Weight of one liter of seed = Liters per hectare



Average Unit Weight of:

- 1 Liter Soybeans = 0.773 Kg
- 1 Liter Milo/Grain Sorghum = 0.721 Kg
- 1 Liter Cotton = 0.412 Kg

If seed population check shows planting rate is significantly different than seed rate chart shows or if a particular meter is not planting accurately, see “Brush-Type Seed Meter Maintenance” and “Brush-Type Seed Meter Troubleshooting”.

GRANULAR CHEMICAL APPLICATION FIELD CHECK

Temperature, humidity, speed, ground conditions, flowability of different material, or meter obstructions can affect granular chemical rate of delivery.

 WARNING	<p>Agricultural chemicals can cause death or serious injury to persons, animals, and plants or seriously damage soil, equipment, or property. Read and follow all chemical and equipment manufacturers labels and instructions.</p>
	

Perform a field check to determine application rates.

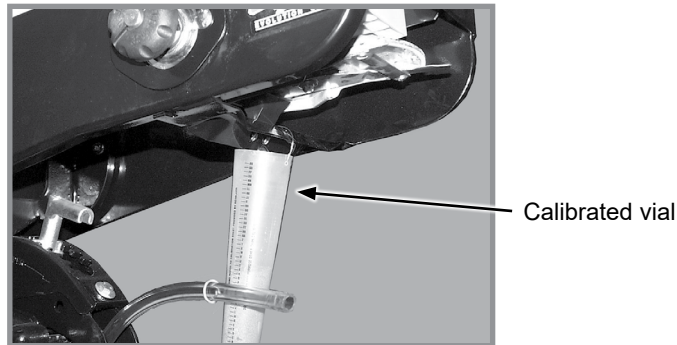

Granular chemical field check

1. Fill insecticide and/or herbicide hoppers.
2. Attach a calibrated vial to each granular chemical meter.

NOTE: Disengage clutch to avoid dropping seed during test.

3. Lower planter and drive 402.3 m at planting speed.
4. Weigh chemical in ounces caught in one vial.
5. Multiply that amount by factor shown to determine kilograms per hectare.

Kilograms Per Hectare	
Row Width	Factor
70 cm	0.0357

EXAMPLE: You are planting 70 cm rows. You have planted for 400 meters at the desired planting speed. You caught 337 grams of chemical in one vial. 337 grams times 0.0357 equals 12 kg per hectare.

NOTE: Check calibration of all rows.

METERING GATE

Use metering gate setting as a starting point for distributing insecticide or herbicide. Charts are based on 8 km/h planting speed. Use a higher gate setting for speeds faster than 8 km/h and a lower setting for speeds slower than 8 km/h.

WATER TANK

The water tank is to only be filled with clean water or preferably potable water (water meeting local standards for drinking). The tank holds 15 liters of water. Be sure to check for regulations pertaining to this use. Tank should be filled with new water at the beginning of each planting season and drained at the end of each planting season.

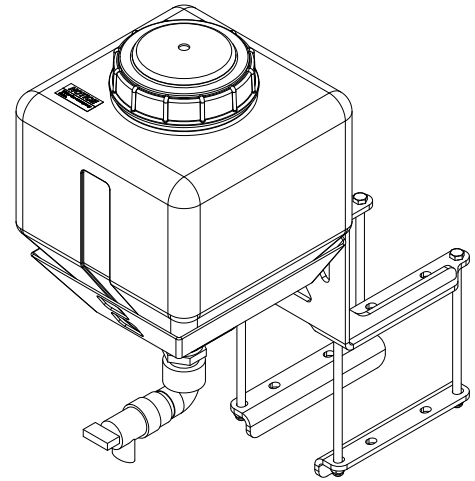

NOTICE

Drain tank if environmental conditions are 0° Celsius or below to prevent tank from cracking.

The water tank is to be used in the event of an accidental exposure to chemical. Chemicals are supplied with Material Safety Data Sheets (MSDS) that provide full information about the chemical, its effects on exposure, and first aid needs in the event of an emergency. Keep your MSDS file up-to-date and available for first responders in case of emergency.

If the water tank is used seek medical assistance immediately for further treatment.

PLANTING DEPTH

Planting depth is maintained by adjustable row unit gauge wheels. Depth adjustment range is approximately 1.2 to 8.9 cm.

1. Raise planter to remove weight from wheels.
2. Push down on depth adjustment handle and reposition it forward to decrease or rearward to increase planting depth. Initially adjust all units to the same setting.
3. Lower planter and check operation and planting depth of all row units. Readjust individual rows as needed for uniform operation.

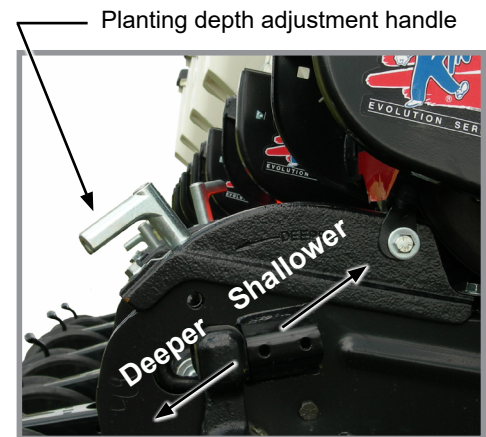

Planting depth adjustment

“V” CLOSING WHEEL ADJUSTMENT (RUBBER OR CAST IRON)

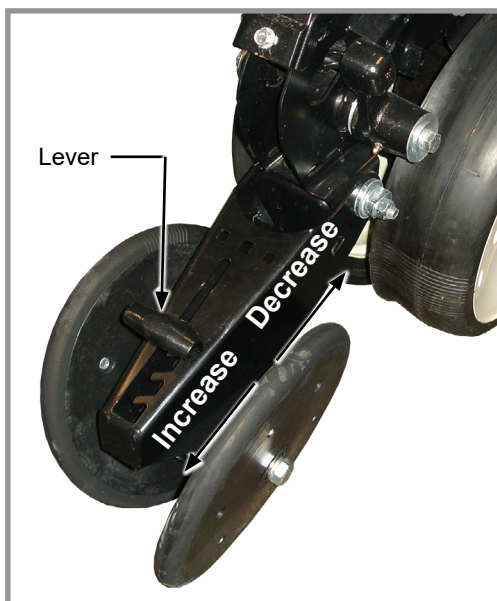

“V” Closing wheels installed offset

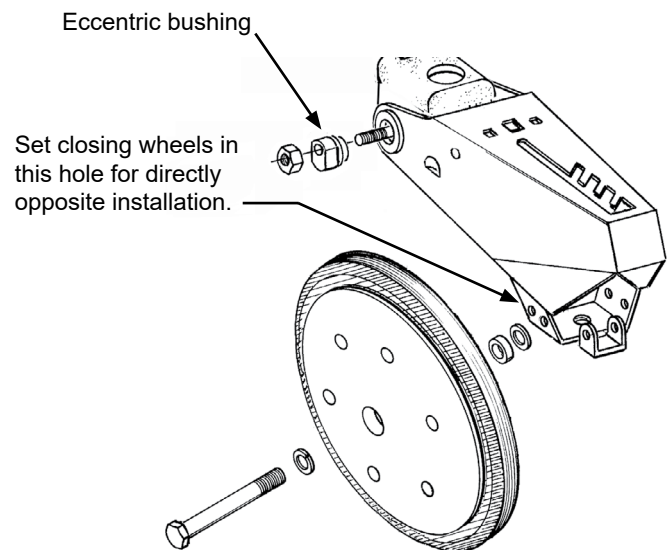

“V” closing wheels should have enough down pressure to close the seed trench and ensure good soil to seed contact. Move 5-position quick adjustable down force lever on the top of closing wheel arm to the rear to increase closing wheel spring pressure. Move lever forward to decrease pressure. Adjust all row units to a similar setting. Light soil usually requires less down force at average depth, approximately 5 cm, while heavy soil requires increased down force.

Eccentric bushings in the wheel arm stop allow for lateral adjustment of the “V” closing wheel assembly. Use a $\frac{3}{4}$ " wrench to loosen hardware attaching closing wheel arm to wheel arm stop. Use another $\frac{3}{4}$ " wrench to turn eccentric bushings until **closing wheels are aligned with seed trench**. Tighten hardware.

Closing wheels can be installed “offset” (to improve residue flow) or “directly” opposite. Use forward installation holes if set “directly” opposite.

CLOSING WHEEL SHIELD (RUBBER OR CAST IRON “V” CLOSING WHEELS)

Optional closing wheel shield is installed on underside of closing wheel arm to help prevent root balls and stalks from clogging closing wheels.

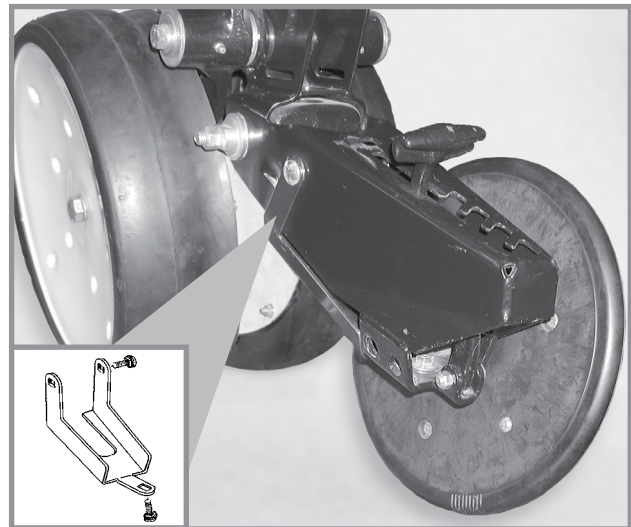

**Closing wheel shield
(Shown with closing wheel removed)**

DRAG CLOSING ATTACHMENT

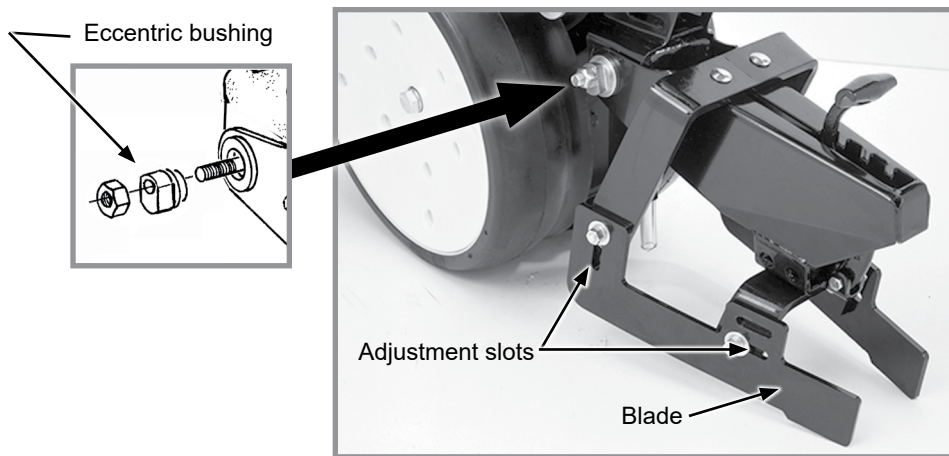

Drag closing attachment

Drag closing attachment pulls loose soil over the seed trench.

NOTE: Use of a seed firming wheel or other seed firming device is recommended with drag closing attachment.

Front and rear adjustment is made using the slotted holes in the blades. Adjust all rows the same.

Eccentric bushings in the wheel arm stop allow for lateral adjustment of the drag closing attachment. Use a 3/4" wrench to loosen hardware attaching closing wheel arm to wheel arm stop. Use another 3/4" wrench to turn eccentric bushings until drag closing attachment is aligned with seed trench. Tighten hardware.

SEED HOPPERS

Mechanical seed hopper has a capacity of 62 liters.

Use clean seed and make certain there are no foreign objects inside when filling seed hopper. **Replace hopper lids after hoppers are filled to prevent accumulation of dust or dirt in seed meter which can cause premature wear.**

Periodically empty hoppers completely to remove any foreign objects and to ensure proper seed meter operation.

Disengage meter drive and hopper latch and lift hopper off hopper support. See "Seed Meter Drive Release".



Mechanical seed hopper

SEED METER DRIVE RELEASE

A clutch release mechanism disengages seed meter drive from seed meter to remove seed hopper. Disconnecting drive allows operator to check granular chemical application rates without dropping seed. It also allows one or more rows to be disconnected when finishing fields.

Turn knob ¼ turn counterclockwise to disengage or ¼ turn clockwise to engage.

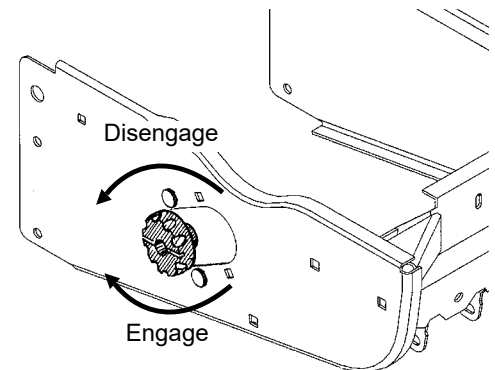

Seed meter drive release

ROW UNIT EXTENSION BRACKETS

Row unit extension brackets extend row units rearward 10.2 cm to provide clearance for coulter mounted residue wheels and HD single disc fertilizer openers.

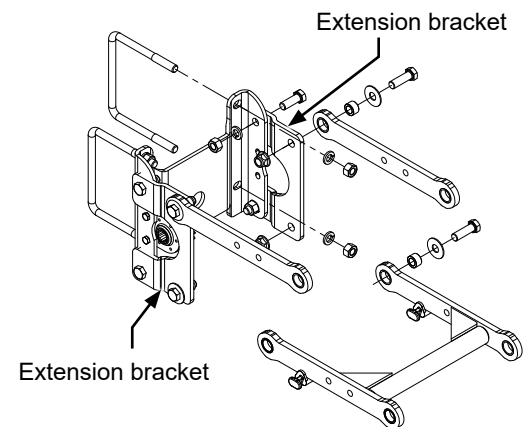

Row unit extension brackets

ROW UNIT CHAIN ROUTING

Row unit drive chains must be properly tensioned and aligned for proper operation and to minimize wear.

Inspect and replace weak, worn or broken springs, idlers, and idler bushings.

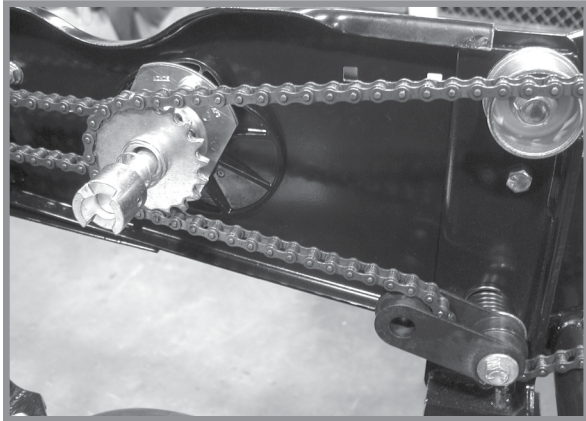

Mechanical pull row unit meter drive

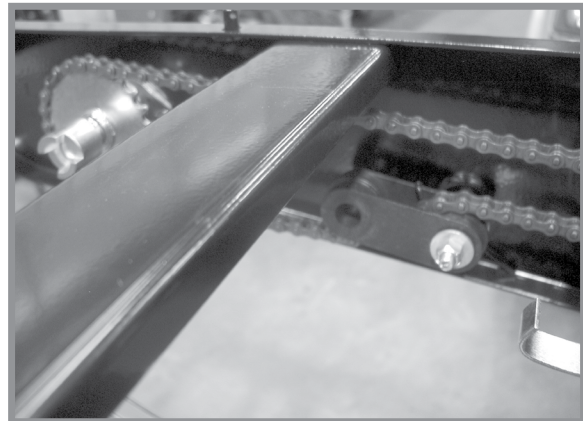

Row unit granular chemical drive

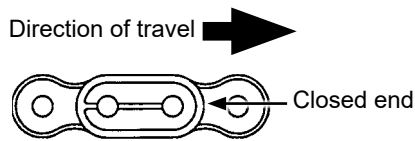

NOTE: Install connector link with closed end facing direction of travel.

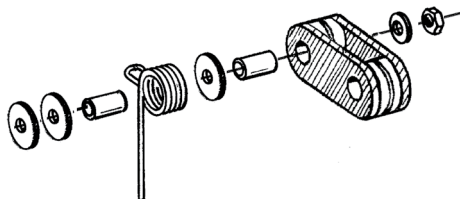

NOTE: Reverse idler when worn on one side for extended use.

QUICK ADJUSTABLE DOWN FORCE SPRINGS OPTION

Quick adjustable down force springs increase penetration in hard soil and keep row unit from bouncing in rough field conditions. Two springs per row, one on each side parallel arms, are used unless equipped with row unit mounted no till coulters. Four springs per row are used with row unit mounted no till coulters.

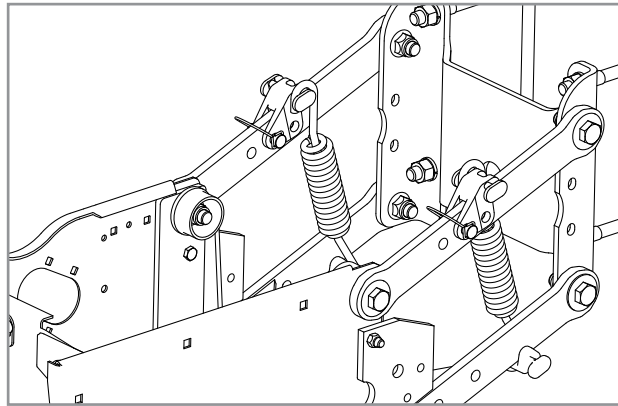

Two Springs Per Row (Dual)

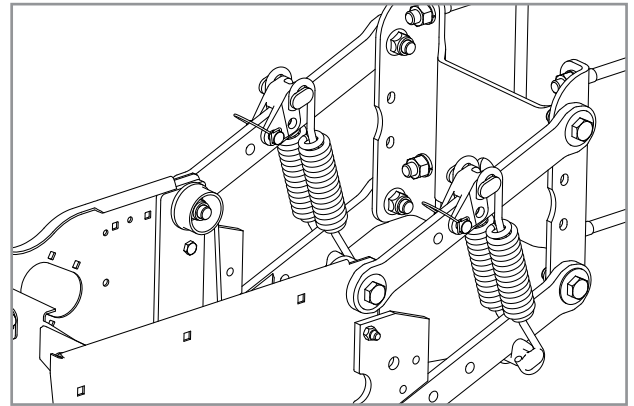

**Four Springs Per Row (Quad)
(Row Unit Mounted No Till Coulters Only)**

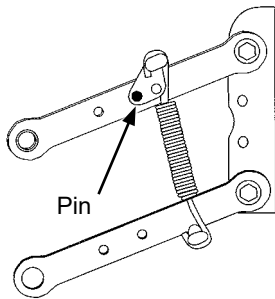

Position 1 (Least)

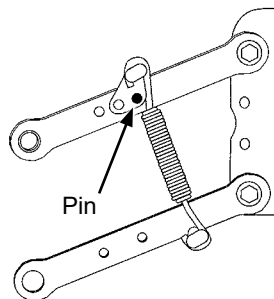

Position 2

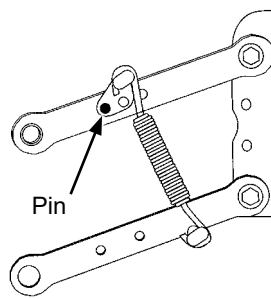

Position 3

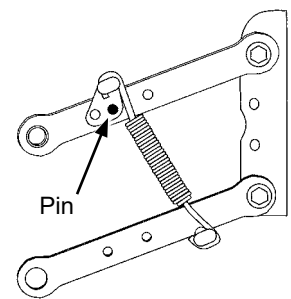

Position 4 (Most)

There are four positions to set down pressure spring tension.

NOTICE	Springs must be installed with open side of spring hooks toward seed hoppers to prevent binding on spring mount adjustment pins.
---------------	---











1. Raise planter and remove spring mount pin at top of spring.
2. Slide mount to desired position and install pin.

NOTE: Adjust springs for field conditions. Too much down pressure in hard field conditions can cause row units to lift planter and keep drive wheels from making contact. Too much down pressure in soft field conditions can cause row unit to run too deep.

Heavy Duty Spring Down Force Pressure*		
	2 Springs	4 Springs
Position	Heavy Duty P/N: D21337	Heavy Duty P/N: D21337
1	43 lb (19.5 kg)	80 lb (36.3 kg)
2	86 lb (39.0 kg)	144 lb (65.3 kg)
3	167 lb (75.7 kg)	307 lb (139.3 kg)
4	249 lb (113.0 kg)	470 lb (213.2 kg)

*Pressure does not include weight of row unit, seed, or options.

BRUSH-TYPE SEED METER

Crop		Disc Color-Code (Disc Part No.)	Upper Brush Retainer	Cells	Seed Size Range	*Lubricant
	Soybean	Black (GA5794)	GD11122	60	4,840 to 8,800 seeds/kg	Graphite Talc
	Specialty Soybean	Dark Blue (GA6184)	GD11122	48	3,080 to 4,840 seeds/kg	Graphite Talc
	Small Milo/Grain Sorghum	Red (GA5982)	GD8237	30	30,800 to 44,000 seeds/ kg	Talc
	Large Milo Grain Sorghum	Light Blue (GA6187)	GD8237	30	22,000 to 35,200 seeds/ kg	Talc
	High-Rate Small Milo/Grain Sorghum	Red (GA5795)	GD8237	60	26,400 to 39,600 seeds/ kg	Talc
	High-Rate Large Milo/Grain Sorghum	Yellow (GA6633)	GD8237	60	22,000 to 30,800 seeds/ kg	Talc
	Cotton, Acid-Delinted	White (GA5796)	GD11122	30	9,240 to 11,440 seeds/kg	Talc
	Large Cotton, Acid Delinted	Tan (GA6168)	GD11122	36	8,360 to 9,680 seeds/kg	Talc
	High-Rate Cotton, Acid-Delinted	Light Green (GA6478)	GD11122	48	9,240 to 11,440 seeds/kg	Talc
	Hill-Drop Cotton, Acid-Delinted	Brown (GA6182)	GD11122	12 (3 to 6 seeds/ cell)	8,800 to 11,400 seeds/kg	Talc
	Small Hill-Drop Cotton, Acid-Delinted	Dark Green (GA7255)	GD11122	12 (3 to 6 seeds/ cell)	11,000 to 13,640 seeds/ kg	Talc

*For More information on application rate see Additives section.

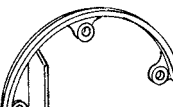
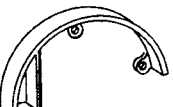
	<p>Use GD11122 upper brush retainer when using cotton and soybean discs.</p>		<p>Use GD8237 upper brush retainer when using milo/grain sorghum discs.</p>
---	--	---	---

Turn seed disc counterclockwise when installing on meter hub while tightening two wing nuts that retain disc. Seed disc should have slight resistance when rotated counterclockwise after wing nuts are tight.

Brush-type seed meter attaches to seed hopper same as finger pickup seed meter. Secure to bottom of seed hopper with two 5/16" thumbscrews. Tighten thumbscrews slightly with pliers. DO NOT OVER TIGHTEN.

Misalignment between drive coupler and seed meter input shaft may cause erratic seed spacing from momentary stoppage of seed disc. Check alignment and adjust as needed.

Refer to planting rate charts in this manual for recommended seed drive transmission sprocket combinations.

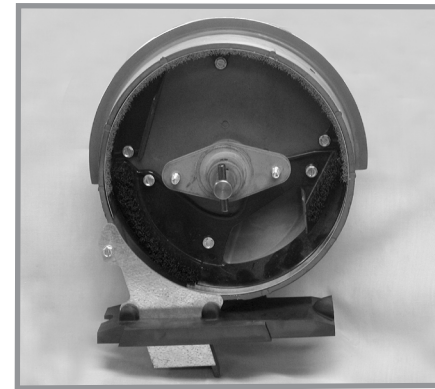





Shown without seed disc installed

NOTE: Clean seed is required to ensure accurate seed metering from brush-type seed meters. Remove seed discs daily and check seed meter or brushes for buildup of foreign material, such as hulls, stems, etc.

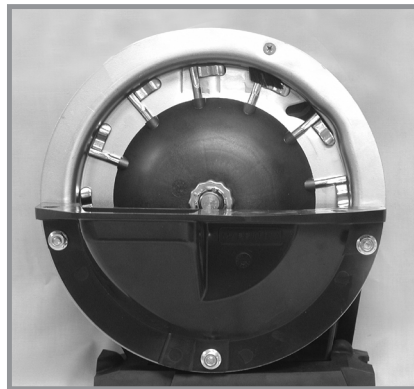
NOTICE	Replace hopper lids after hoppers are filled to prevent accumulation of dust or dirt in seed meter which will cause premature wear.
---------------	--

FINGER PICKUP SEED METER

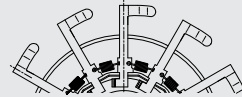









Crop	Fingers	*Lubricant
Corn	 Part No.: GR1848 - Finger Assembly, Corn	Graphite Talc
No. 1 and/or No. 2 size Confectionery Sunflower Seeds	 Part No.: GR1848 - Finger Assembly, Corn	Talc
No. 3 and/or No. 4 size Oil Sunflower Seeds	 Part No.: GR2154 - Finger Assembly, Oil	Talc
Blank fingers replace alternate fingers to reduce planting rate by half while allowing the finger wheel to maintain a minimum of 40 RPM when planting low rates.	 Part No.: GD11787 - Half Rate Blank Finger	Graphite Talc

***For More information on application rate see Additives section.**

NOTE: Always field check seed population to verify planting rates.

NOTE: Refer to planting rate charts in this manual for recommended seed drive transmission sprocket combinations.

VACUUM SETTINGS

Crop		**Seed Disc Kit	Seed Disc Part No.	Ejector Wheel (Color)	Cells	Seed Size Range	Singulator Zone Setting	Vacuum Setting Inches of Water (kPa)	Lubricant
	Corn ‡ Large Sweet Corn	G11152X	B1219 (Light Blue)	1 row 5 punches (Light Blue)	40	2500-5000 seeds/kg	2	18-20 (46-51)	Graphite* Talc*
	Soybean	G11047X	B1232 (Black)	2 rows 6 punches (Black)	120	4850-8820 seeds/kg	0	10-14 (25-36)	Graphite* Talc*
	Sugar Beet	G11154X	B1229 (Dark Orange)	1 row 6 punches (Dark Orange)	60	Pelletized	2	15 (38)	Graphite*
	Sunflower ‡ Small Sweet Corn	G11153X	B1230 (Gray)	1 row 5 punches (Gray)	40	Oil seeds #2, 3, 4	2	12-18 (30-46)	Graphite* Talc*
	Sunflower	G11153X	B1230 (Gray)	1 row 5 punches (Gray)	40	Oil seeds #5	2	5-8 (13-20)	Graphite* Talc*
	Specialty Disc 1	G11105X	BB1233 (Green)	1 row 6 punches (Green)	60	Cotton	2	15-20 (38-51)	Graphite* Talc as needed*
	Specialty Disc 2	G11106X	B1235 (Brown)	1 row 6 punches (Green)	60	Black turtle & navy edible beans	2	15-20 (38-51)	Graphite* Talc as needed*
	Specialty Disc 3	G11107X	B1234 (Dark Blue)	1 row 6 punches (Green)	60	Pinto & Great Northern edible beans & low-rate soybean	2	15-20 (38-51)	Graphite* Talc as needed*
	Rapeseed	G11046X	B1239 (Dark Gray)	1 row 10 punches (Dark Gray)	83	See "Rapeseed Planting Section" on page 3-13	0	See "Rapeseed Planting Section" on page 3-13	Kinze Brand Graphite Only

Install selected seed disc. Position vacuum cover on meter by aligning keyhole slots over bolt heads. Push cover on meter and turn counter clockwise to lock in place.

*For More information on application rate, see Additives section.

**Includes seed disc, ejector wheel, and spring.

NOTE: See “Check Seed Population” located in this manual for more information. Always field check seed population to ensure planting rates are correct.

NOTE: Singulator zone settings are marked from 1, 2, 3, and 0.

NOTE: Mixing seed sizes and shapes affects meter performance. Use consistent seed size and shape.

NOTE: Use 1 tablespoon (5 mL) powdered graphite with each standard hopper fill of seed. Seed treatment, foreign material, dirt or seed chaff may cause gradual reduction of seed disc fill (population). See “Additives” pages for more information.

NOTE: Excessive seed treatment, humidity, and light-weight seed can affect meter performance. Use ½ cup (118 ml) of talc with each standard hopper fill of seed and mix thoroughly to coat all seeds and adjust rates as needed. Use of talc aids seed flow into meter, singulation, and disc seed drop.

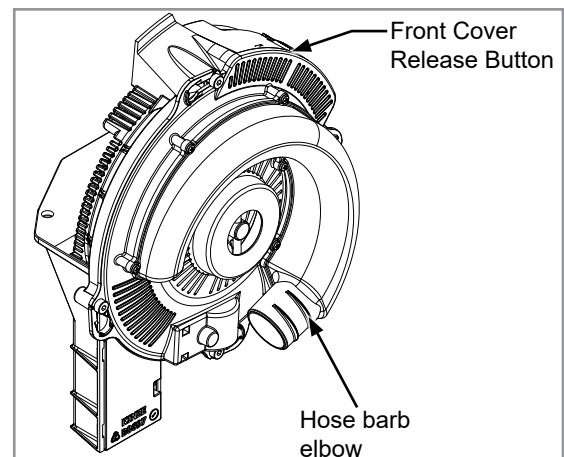
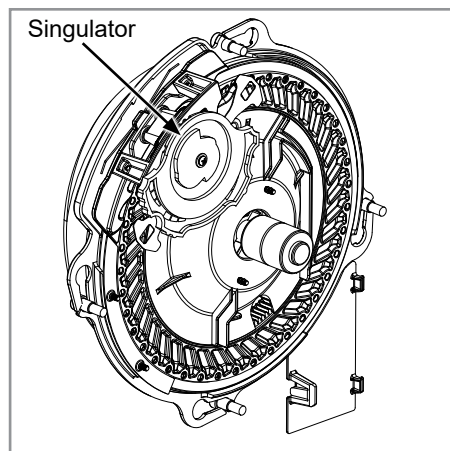

NOTE: Foreign material in seed disc orifices, such as seed chips, hulls, stems, etc., may affect seed delivery. Clean seed ensures accurate seed metering from vacuum seed meter. Remove Seed discs daily to check for buildup of foreign material in seed disc orifices.

Air inlet screens allow air to enter system and aids in keeping field residue or other foreign material out of meter.

See “Vacuum Seed Meter Maintenance” and “Preparing Planter for Storage” in Lubrication and Maintenance section for more information.

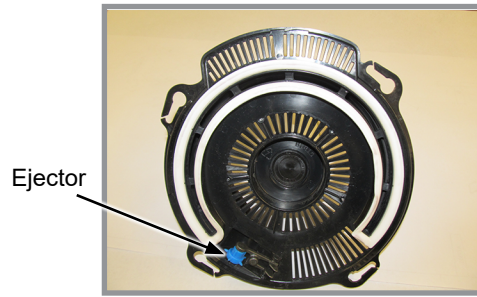

NOTE: Damaged seed or seed containing foreign material will cause plugging of seed disc orifices and require more frequent seed meter cleanout to prevent underplanting.

Wheel-Type Ejectors

Wheel-type ejectors expel seed remnants from seed disc orifices. These ejectors are disc specific and colored coded to match disc.

NOTICE	Replace hopper or tank lids after filling to prevent accumulation of dust or dirt in seed meter resulting in premature wear.
---------------	---

NOTE: Seed size, seed shape, seed treatments, travel speed, and planting rate affect meter performance.

1. Select seed disc and ejector to match crop and population.

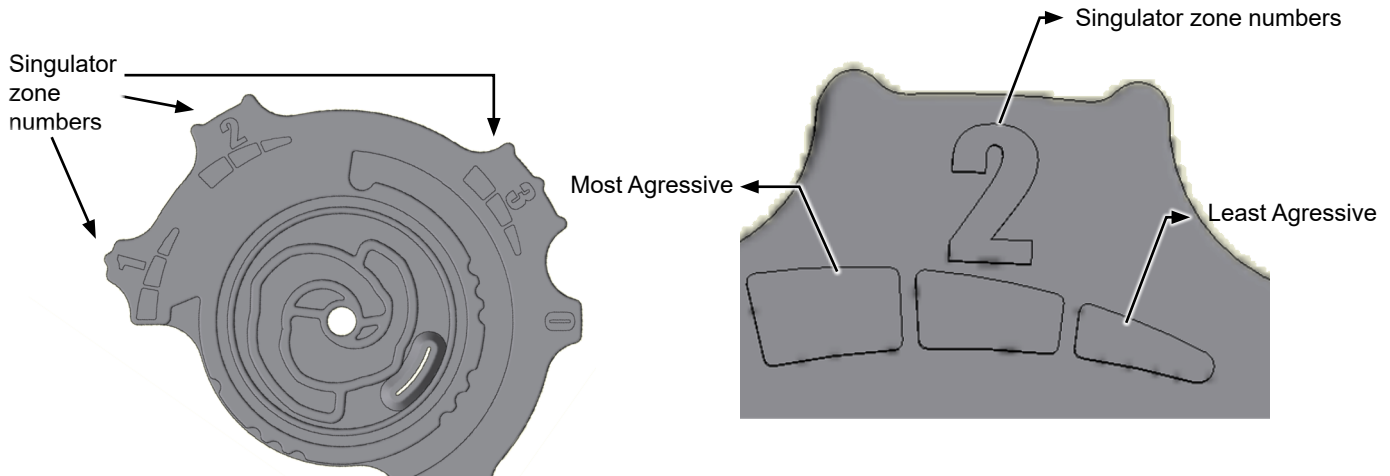

Singulator Adjustment Wheel

2. Adjust singulator wheel to initial setting. Seed size, seed shape, seed treatments, travel speed and planting rate all affect meter performance.
3. With vacuum fan running, lower planter to planting position and drive forward a short distance to load seed into seed disc cells.
4. Adjust vacuum level to initial setting according to tables on page using needle valve.

NOTE: Vacuum reading will be much lower when seed disc cells are empty. Load all seed cells before setting vacuum level.

NOTE: Operate vacuum fan 3-5 minutes to bring oil up to normal operating temperature prior to making final vacuum level adjustment.

NOTE: Tractor RPM are not recommended to be below 1750 RPM.

ADDITIVES

Lubricant Application Rate	
Graphite	
Conventional Hoppers	1 Tbs. (15 ml)/Hopper Fill
80/20 Talc-Graphite	
Conventional Hoppers	120 ml.**
**Must be evenly mixed during fill.	
Talc	
Conventional Hoppers	60 ml.*
*Double amount of talc for sunflowers.	

GRAPHITE

The use of graphite is the primary recommendation to promote seed flow, provide lubrication for the seed meter and to help dissipate static charge buildup. Among the available dry seed lubricants graphite is the most effective and easiest to use and it requires no mechanical agitation

Conventional Hoppers

Mix one tablespoon of **powdered graphite** with seed each time hoppers are filled. Regular graphite use prolongs life of the seed meter components, improves seed spacing, and may reduce buildup of seed treatments.

NOTE: DO NOT apply graphite only in center of hopper. It will filter too quickly through the seed and not distribute as evenly as desired.

Apply graphite around outer perimeter of hopper.



Adding graphite to conventional hopper

NOTE: Additional graphite may be required to retard buildup of seed treatments on meter components. More frequent cleaning of monitor seed tubes may be necessary due to use of additional graphite.

80/20 TALC-GRAPHITE

Talc-Graphite lubricant is to be used for treated seed, providing benefits of both talc and graphite. It absorbs moisture to prevent bridging, minimizes static electricity for improved seed flow, and lubricates seed and meters.

Conventional Hoppers

Mix 120 ml of 80/20 talc-graphite evenly with seed each time hoppers are filled. Regular graphite use prolongs life of the seed meter components, improves seed spacing, and may reduce buildup of seed treatments.

NOTE: Talc-Graphite lubricant MUST be mixed evenly during fill.

TALC

Talc seed lubricant may be used as a drying agent in addition to graphite lubrication. The drying agent may improve seed release and/or **to retard buildup of seed treatments on meter components.**

1. Fill hopper ½ full of seed, add 60 ml (conventional) of talc and **mix thoroughly**.
2. Finish filling hopper, add another 60 ml (conventional) of talc and **mix thoroughly**.
3. Adjust rate of talc use as needed so all seeds are coated, while avoiding a buildup of talc in bottom of hopper.

Humid conditions and/or small sized seeds with extra seed treatment may require additional talc to maintain meter performance.

NOTE: Liquid seed treatments or inoculants may create buildup on the seed disc or brushes. Check frequently for proper population and/or seed delivery when using any liquid seed treatment.

Completely mix all treatments with seed following manufacturers' recommendations. Seed treatment dumped on top of seed after hopper is filled may not mix properly and cause seed bridging, reducing population or stopping meter from planting.

RAPESEED PLANTING SECTION

**DUE TO POTENTIAL SEED LOSS THROUGH THE AIR DISSIPATOR SCREEN,
RAPESEED PLANTING WITH BULK FILL EQUIPPED PLANTERS IS
NOT RECOMMENDED BY KINZE.**

MONITOR SETTINGS

KPM III	
Meter Type:	Vacuum
Meter Sprocket:	28 Tooth
Crop Type:	Other Small Seed
Seeds Per Rev:	83
Seed Size:	1
Split Rows:	Enable

See KPM III Electronic Seed Monitor Operator Manual for more details.

NOTE: Because of small seed size and high seeding populations, it is possible in certain planting conditions that not all seeds will be detected by the row unit seed sensor. So it is possible KPM III and Ag Leader InCommand or Integra monitors might not show correct seeding accuracy. Monitor planting accuracy alarm may be required to be adjusted to lower accuracy (or muted) due to false accuracy alarms. Frequent field checks are recommended.

VACUUM SETTINGS

Due to rapeseed size and weight variations planting settings may vary. Testing with a Kinze T4000 test stand is recommended to verify vacuum level setting and to achieve best planting accuracy. See your Kinze dealer for testing.

Set desired vacuum to value found during testing (recommended) or use preliminary values provided in chart below.

If testing is unavailable measure 20 - 50 seed samples and find average seed diameter (largest - width/length/height seed dimension).

Target Speed (km/h)	Target Population	Target Vacuum (inches (cm) of water)		
		Small Seed Diameter Range: 1,2 - 2,0mm (Average: 1,6mm)	Medium Seed Diameter Range: 1,5-2,5mm (Average: 2,0mm)	Large Seed Diameter Range: 1,6-3,1mm (Average: 2,6mm)
8	350000	4" (~10 cm)	4" (~10 cm)	6" (~15 cm)
8	500000	4" (~10 cm)	6" (~15 cm)	8" (~20 cm)
8	650000	4" (~10 cm)	8" (~20 cm)	12" (~30 cm)
8	800000	4" (~10 cm)	12" (~30 cm)	16" (~40 cm)
10	350000	4" (~10 cm)	6" (~15 cm)	8" (~20 cm)
10	500000	4" (~10 cm)	8" (~20 cm)	12" (~30 cm)
10	650000	4" (~10 cm)	10" (~25 cm)	14" (~35 cm)
10	800000	6" (~15 cm)	12" (~30 cm)	16" (~40 cm)

ADDITIVES

Rapeseed

It is essential to use graphite to neutralize electrostatic rapeseed properties.

Mix rapeseed with Kinze graphite thoroughly in a closed container. Keep mixing until all seed becomes evenly coated. Excessive graphite will stay on the bottom of container. It is recommended to prepare an even amount of seed-graphite mix for each hopper separately. This will help to monitor each row performance while planting.

Use approximately 1Tbs (~15ml) of graphite per 3-4 l of seed.

NOTE: For best performance Kinze brand graphite MUST be used.



RATE CHARTS

For Rapeseed Rate Charts, [See “Rate Charts” on page 5-1](#) section of this manual.

VACUUM METER INSULATION FOR RAPESEED PLANTING

Additional insulating shims for Vacuum Meters are needed in order to successfully and efficiently plant rapeseed with Blue Drive equipped machines, as they prevent the seeds from getting crushed, thus clogging up the seed disc. The shims are obligatory on Blue Drive planters, but provide a tangible benefit when used on Ground Contact Drive planters as well. The instructions below detail the process of shim insertion and removal, as well as washing of seed discs.

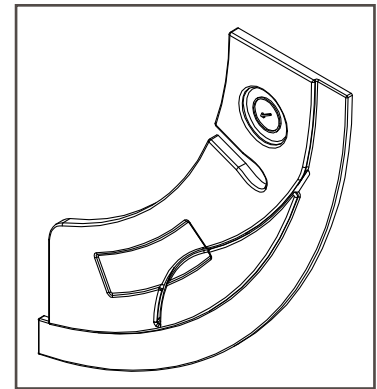

Rapeseed Meter Insulation Shim

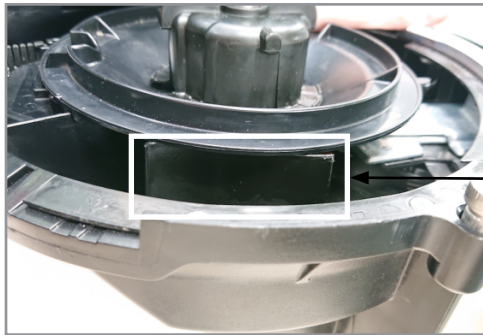

Place of the Shim on the Baffle

Inserting the Insulation Shim:

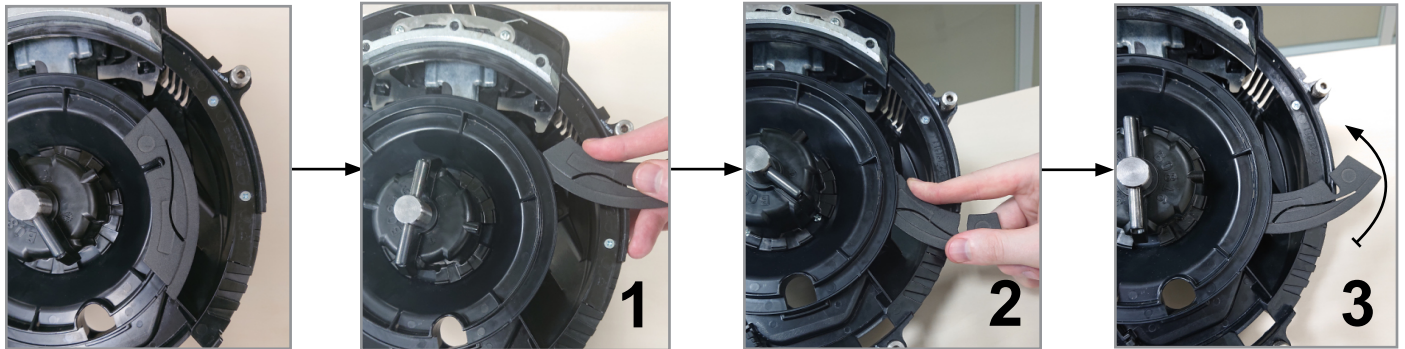

1. Begin inserting the Insulation Shim by sliding the tail end of it inside the gap indicated above, knife-like (img. 1).
2. Once initially inserted in the gap, rotate the Shim to the left by about 90° (img. 2 & 3).
3. Proceed to apply continual pressure while also maintaining the desired direction with your fingers until the shim is securely inserted (the longitudinal contoured gap in the shim is aligned with the contour of the baffle of the vacuum meter on which it sits, the shim clicks into place)(img. 4, 5 & 6).

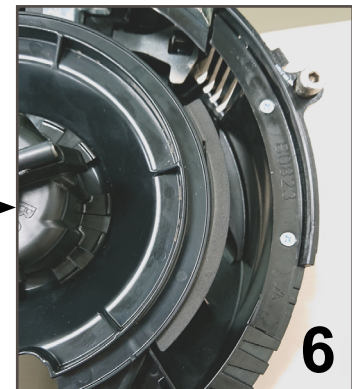

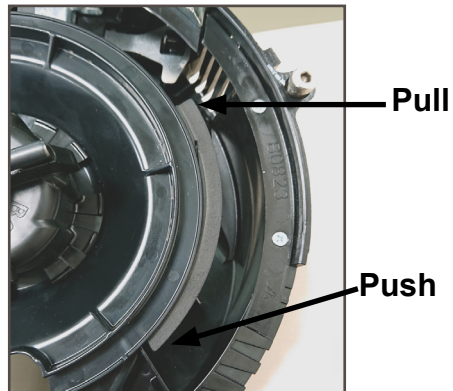
Removing the Insulation Shim:

To remove the Insulation Shim, push down with your fingers on one end, while pulling on another end (see img. above).

Washing Seed Discs:

When planting Rapeseed, Seed Discs will periodically need to be scrubbed and washed with soap and water to remove the accumulated oils and debris, which prevent the disc from functioning optimally. Maintaining clean discs will ensure the best planting results.



SPIKED CLOSING WHEEL

Spiked closing wheels crumble the sidewall, allowing roots to penetrate soil. They can be used on pull row units and push row units.

Align spiked closing wheels straight across from each other, in most rearward holes on closing wheel arm. Set the wheels 25 - 32 mm apart at the closest point. If large amounts of contouring is being done, mount wheels in the forward most hole. This will reduce drifting of row unit.

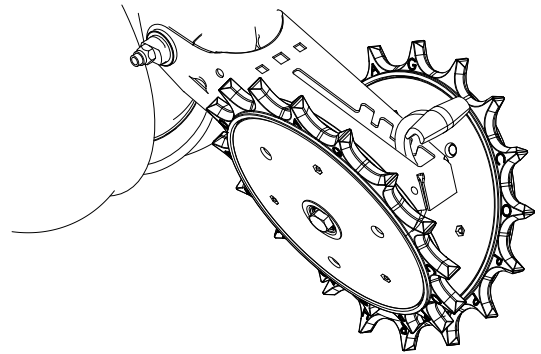

Row Unit Spiked Closing Wheel

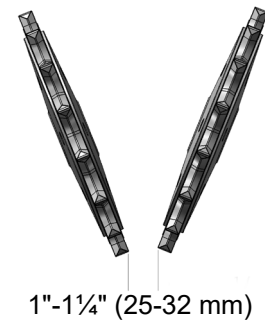

ROW UNIT MOUNTED RESIDUE WHEEL

Row unit mounted residue wheel are used on pull and push row units.

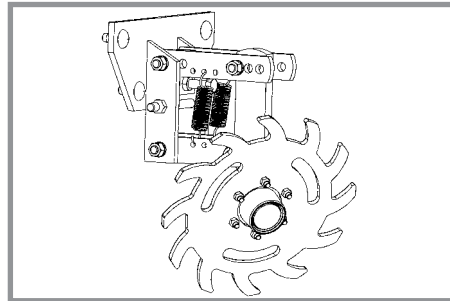

Two adjustable springs on each residue wheel parallel links provide down force adjustment. Position 1 provides minimum down pressure and position 3 maximum down pressure.

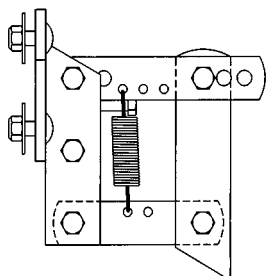

Position 1 (Least)

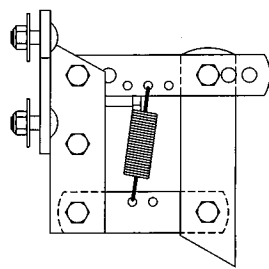

Position 2

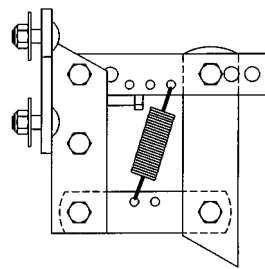

Position 3 (Most)

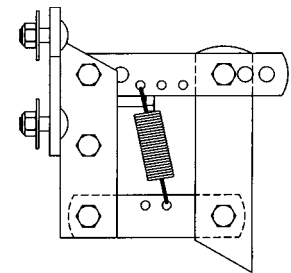

Additional uplift or float

Raise row unit and reposition springs to adjust down pressure.

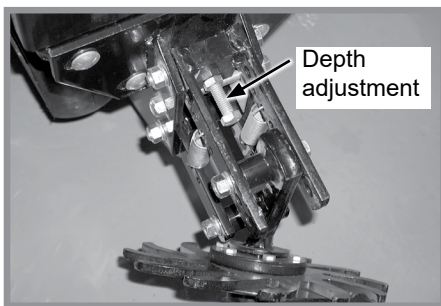

Wheel depth adjustment

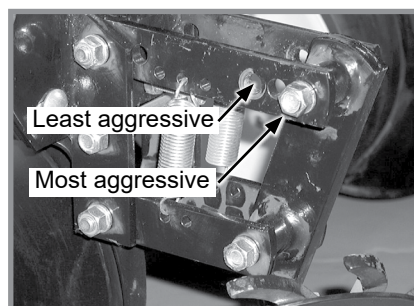

Wheel angle adjustment

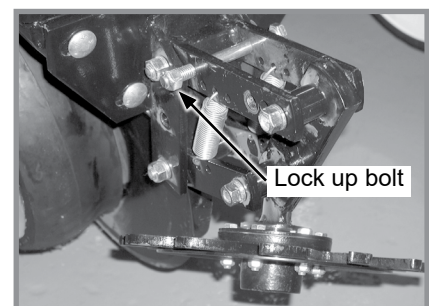

Wheel lock up

A full threaded bolt and jam nut located on the upper link sets maximum depth for loose soil conditions. Initial setting is 45 mm above row unit double disc opener depth.

Three holes in upper link adjust wheel angle. With wheel mount in most vertical position, using the rear hole in the upper link, the residue wheel is most aggressive. Moving wheel mount to a forward hole reduces aggressiveness of residue wheel for use in mulch till applications where soil is loose.

To lock residue wheel up, remove 1/2" x 5" lockup bolt, raise residue wheel and install bolt.

ROW UNIT MOUNTED NO TILL COULTER



Row unit mounted no till coulters with 1" bubbled (25 mm), 1" (25 mm) fluted (8 flutes) or $\frac{3}{4}$ " (19 mm) fluted (13 flutes) blades may be used on pull row units and push row units ($\frac{3}{4}$ " fluted shown). Four quick adjustable down force springs are required per row when using row unit mounted no till coulters. See "Quick Adjustable Down Force Springs Option".

Align coulters blade in relation to row unit double disc openers. Adjust by loosening four attaching bolts, moving coulters arm, and tightening four attaching bolts. Coulters blade can be adjusted to one of four 13 mm incremental settings in the forked arm. Initial location is the top hole. Move blade as it wears to one of the three lower hole to maintain coulters blade at or slightly above opener discs as needed. Adjust coulters below depth of double disc opener blades in very hard soil conditions such as compacted wheel tracks to improve opener penetration and cutting of surface residue.

Check operating depth by setting planter down on a level concrete floor and checking relationship between coulters blade and row unit opener blade. Make sure planter is level and coulters is square with planter frame and aligned with row unit disc opener.

NOTE: Torque $\frac{5}{8}$ " spindle hardware to 163 Nm.

COULTERS MOUNTED RESIDUE WHEELS

Coulters mounted residue wheels are designed for use on pull row units and push row units. Row unit extension brackets are required on the four center pull row units if the planter is equipped with coulters mounted residue wheels.

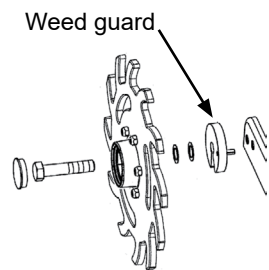

NOTE: Opening in weed guard must face down.



Residue wheels attach to row unit mounted coulters with two cap screws and sleeves allowing unit to free-float. A 2-position spindle bolt mounting positions wheels interlocked or staggered. Depth adjustment is made with a spring-loaded cam and pin with 11 positions in 6 mm increments. A high point on the cam allows wheels to be locked up.

A weed guard on the inboard side of each wheel helps prevent weed wrap which can cause premature bearing failure.

GRANULAR CHEMICAL HOPPER AND DRIVE



Agricultural chemicals can cause death or serious injury to persons, animals, and plants or seriously damage soil, equipment, or property. Read and follow all chemical and equipment manufacturers labels and instructions.

The granular chemical hopper has a 40 liters capacity.

Make sure no foreign objects get into hopper when it is being filled. Replace hopper lids after filling to prevent accumulation of dirt and moisture.

A metering gate on bottom of hopper regulates the application rate. See “Dry Insecticide and Dry Herbicide Application Rate Charts” in this manual. Calibrate using chemical manufacturers’ instructions.



Granular chemical hopper

Granular chemical clutch drive coupler and meter shaft can be disengaged and engaged by turning throwout knob at rear of hopper support panel.

Rotate knob $\frac{1}{4}$ turn counterclockwise to disengage and $\frac{1}{4}$ turn clockwise to engage.

Slotted holes in hopper support panel and clutch housing allow for alignment adjustment between clutch drive coupler and meter shaft.

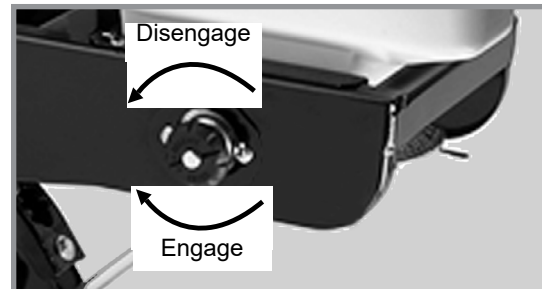

Granular chemical drive release

GRANULAR CHEMICAL BANDING OPTIONS

Granular chemical banding options allow 155 mm (4½") slope-compensating banding or straight drop in-furrow placement.

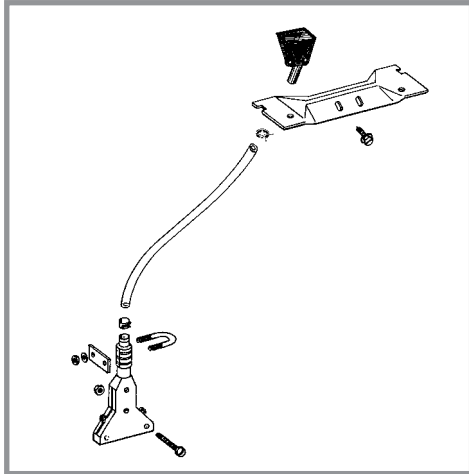

155 mm (4½") Slope-Compensating Bander

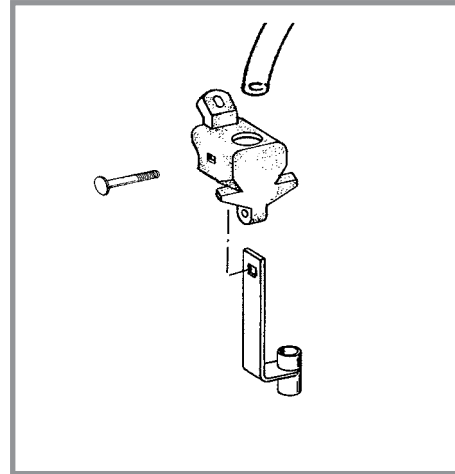

Straight Drop In-Furrow Placement

GRANULAR CHEMICAL BANDER SHIELD

Optional granular chemical bander shield is installed on underside of wheel arm stop to shield crop residue from lodging in granular chemical bander.

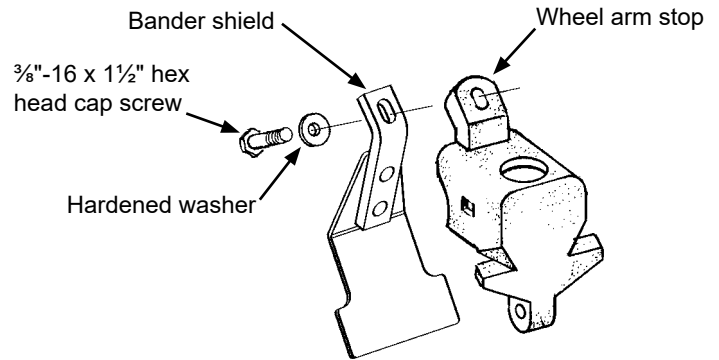

Granular chemical bander shield installation

DOUBLE DISC FERTILIZER OPENER

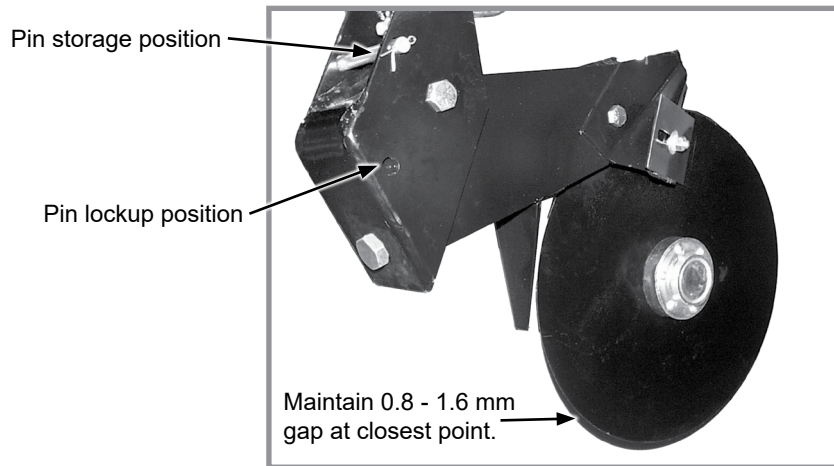

Double disc fertilizer opener

Position double disc fertilizer openers **to place fertilizer no closer than 5 cm to either side of row**. Fertilizer depth is approximately 10 cm if planter frame is level and at proper 51 cm operating height. Soil conditions can affect depth slightly.

NOTE: Do not set opener depth with spring pressure. Opener is designed to operate against a depth stop and spring up when encountering a foreign object or hard ground.

Down pressure spring is factory preset at 113 kg but can be adjusted for various soil conditions.

1. Loosen jam nut with a $1\frac{5}{16}$ " wrench.
2. Use a 1" wrench to turn adjustment bolt clockwise to increase tension or counterclockwise to decrease tension.
3. Tighten jam nut.

NOTICE

Do not operate double disc openers at full down pressure tension on rocky ground or disc blades will chip.

Maintain a gap of .8 - 1.6 mm between opener blades at the closest point. Blade adjustment is made by moving inside spacer washers to outer side of blade. Check bearing assembly rivets are not contacting shank after making adjustment.

Outer scrapers on each disc blade can be adjusted for wear. Make sure scrapers are adjusted to allow only slight blade contact.

Opener assembly is designed to be locked in a raised position when fertilizer attachment is not in use or during storage.

1. Raise planter and place blocks under openers.
2. Lower planter until pivot section hole aligns with mounting bracket hole.
3. Remove lockup pin from mounting bracket storage position and install through lockup hole.
4. Secure with cotter pins.

NOTCHED SINGLE DISC OPENERS

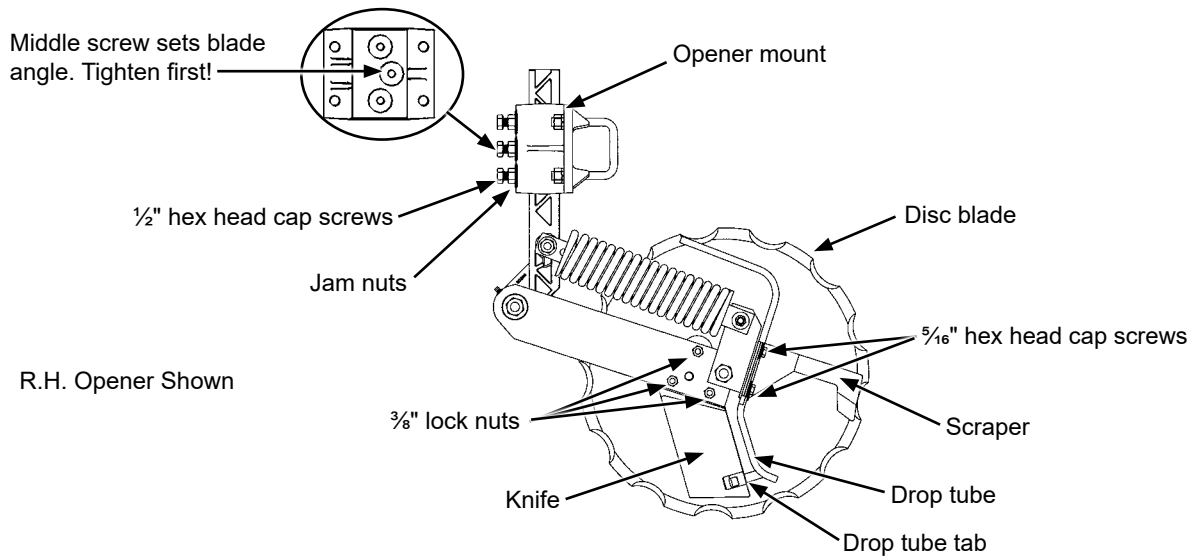

Notched single disc opener adjustments

 CAUTION	<p>Compressed spring may fly out of this assembly if attempting to disassemble and cause injury. Do not take apart this assembly.</p> <p>Disc blades are sharp and can cut causing serious injury. Wear gloves when working on or turning disc blades by hand.</p>
---	--

NOTICE	<p>Never strike knife with heavy object. Damage to knife will occur.</p> <p>If knife to disc blade clearance is too large, soil or residue can wedge between knife and blade, and blade will not turn.</p>
---------------	--

1. Adjust knife to disc blade contact. Loosen or tighten $\frac{3}{8}$ " lock nuts to adjust knife's entire leading edge against disc blade. Turn blade and check for slight resistance without freewheeling. Readjust knife to blade's tight spot as needed.

NOTICE

Adjust liquid drop tube out of path of soil flow across knife. Drop tube and tab wear quickly if not correctly adjusted.

2. Adjust scraper and drop tube. Loosen two $\frac{5}{16}$ " hex head cap screws. Adjust scraper until just touching disc blade. Adjust drop tube until it is centered between knife and disc blade. Tighten screws. Turn blade and check for slight resistance without freewheeling. Repeat as needed. Insert flat bladed pry bar or screwdriver between knife and drop tube above drop tube tab. Carefully bend tube until 6 - 10 mm from disc blade.

NOTE: Maximum disc blade depth 10.2 cm.

3. Adjust blade depth. Loosen three $\frac{1}{2}$ " hex head cap screws and jam nuts in opener mount. Adjust opener assembly up or down to desired blade depth. Tighten center hex head cap screw and jam nut first to set proper disc blade angle. Tighten remaining hex head cap screws and jam nuts. Torque hex head cap screws and jam nuts to 77 Nm. Check fertilizer hose clearance and adjust as necessary.

RESIDUE WHEEL ATTACHMENT FOR NOTCHED SINGLE DISC FERTILIZER OPENER



Notched single disc opener residue wheel attachment

Residue wheel attachment for notched single disc fertilizer opener is used where row unit mounted residue wheel attachments cannot be installed. Residue wheel is attached to notched single disc fertilizer opener with $\frac{5}{8}$ " x $7\frac{1}{2}$ " (L=190 mm) and $\frac{1}{2}$ " x $6\frac{1}{2}$ " (L=165 mm) hardware.

Maximum depth is set by lifting residue wheel and moving adjustment lever down to increase depth or up to decrease depth in 25 mm increments (in relation to blade depth setting). Adjust all rows the same. Residue wheel down force is maintained by a torsion spring and is not adjustable.

DEPTH/GAUGE WHEEL ATTACHMENT FOR NOTCHED SINGLE DISC FERTILIZER OPENER

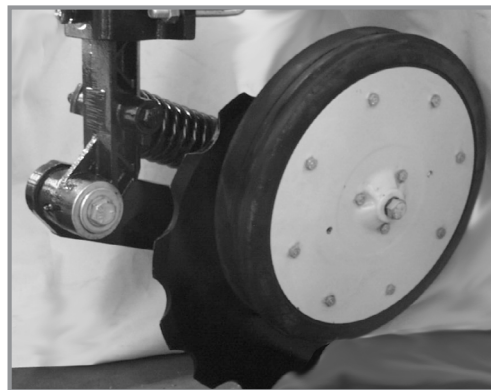

Notched single disc opener depth/gauge wheel

Depth/gauge wheel attachment for notched single disc fertilizer opener is used where additional gauging is required to maintain desired fertilizer opener depth. Depth/gauge wheel is attached to notched single disc fertilizer opener using a mounting block fastened to the pivot arm with $\frac{5}{8}$ " hardware through disc blade bearing.

Depth adjustment is made using 3 adjustment holes in depth/gauge wheel mounting block. Moving depth/gauge wheel increases/decreases depth in approximate 25 mm increments in relation to blade depth setting made at vertical mounting post.

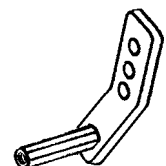

HD SINGLE DISC FERTILIZER OPENER

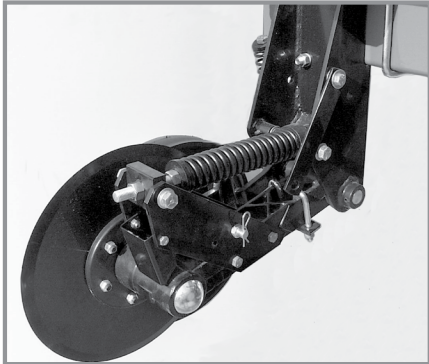

HD single disc opener

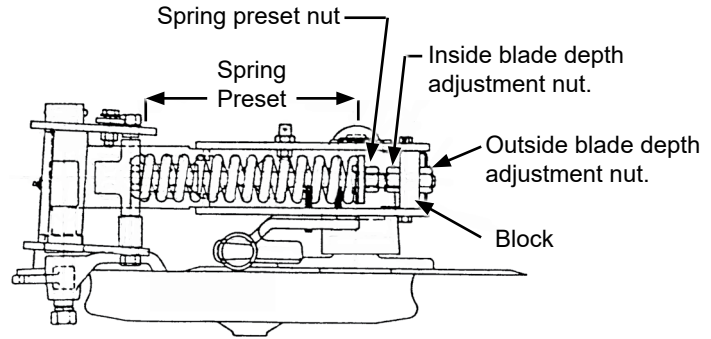

R.H. configuration shown (Overhead view)

Recommended placement of fertilizer with HD single disc fertilizer opener is 9 - 10 cm from row.

NOTICE	Never place fertilizer closer than 5 cm to row or seeds may be damaged.
---------------	--

Maximum blade depth is approximately 13 cm with planter frame level and at 51 cm operating height. Soil conditions can affect depth slightly.

Raise planter to remove weight from fertilizer opener. Loosen inside adjustment nut with 1 1/8" wrench. Turn outside nut clockwise to decrease or counterclockwise to increase blade depth. One full turn of blade depth adjustment nut changes blade depth 3/8". Tighten inside nut tight against block. Adjust all fertilizer openers to same depth.

Fertilizer opener down pressure can be adjusted from 113 kg to 290 kg.

NOTICE	Do not operate HD single disc fertilizer openers at full down pressure tension on rocky ground or disc blades will chip.
---------------	---

NOTE: DO NOT adjust spring preset dimension less than 24 cm.

NOTE: Excessive down pressure can cause planter frame up-lift and affect machine performance. Planter frame should be 51 cm from ground in planting position. Excessive down pressure in loose soil conditions can cause openers to run too deep and push dirt ahead of opener and may stop soil press wheel and opener blade from turning.

Raise planter to remove weight from fertilizer opener. Turn spring preset nut clockwise to increase and counterclockwise to decrease down pressure. Adjust all rows to a similar setting. Minimal spring pressure for acceptable operation is recommended. See chart for spring length setting specifications.

Spring Preset	
Length	Down Pressure
11" (28 cm)	250 lb (113 kg)
10 3/4" (27 cm)	320 lb (145 kg)
*10 1/2" (27 cm)	370 lb (168 kg)
10 1/4" (26 cm)	450 lb (204 kg)
10" (25 cm)	520 lb (236 kg)
9 3/4" (25 cm)	580 lb (263 kg)
9 1/2" (24 cm)	640 lb (290 kg)
*Initial setting	

Adjust spring loaded dry fertilizer drop tube/scrapper periodically to maintain 3 mm gap between drop tube and opener blade. If this dimension is not maintained fertilizer may not drop in proper location.

Loosen scraper adjustment bolt. Slotted hole in scraper allows up or down adjustment.

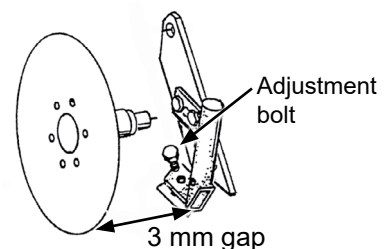

Adjust liquid drop tube/scrapper so there is slight contact between blade and scraper lower leading edge, and 6 mm (clearance between liquid drop tube trailing edge and blade. Blade should turn with minimum amount of drag.

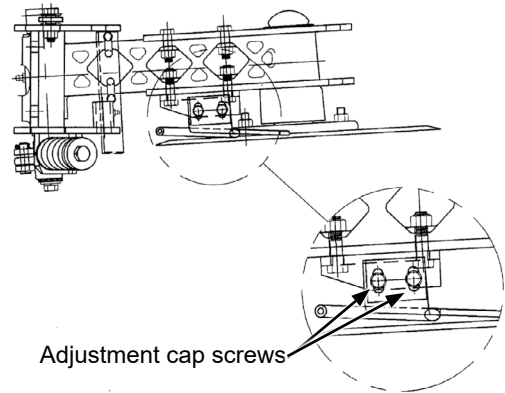

HD single disc fertilizer opener can be raised and locked up when fertilizer attachment is not used or during storage.

NOTE: A lockup bar automatically raises and locks soil press wheel when blade assembly is raised.

1. Place planter in planting position.
2. Remove outside blade depth adjustment.
3. Raise planter until adjustment bolt clears adjustment block.
4. Raise spring to clear blade assembly and raise blade assembly until storage strap can be positioned on lockup pin. Install hair pin clip.
5. Reinstall depth adjustment nut and tighten

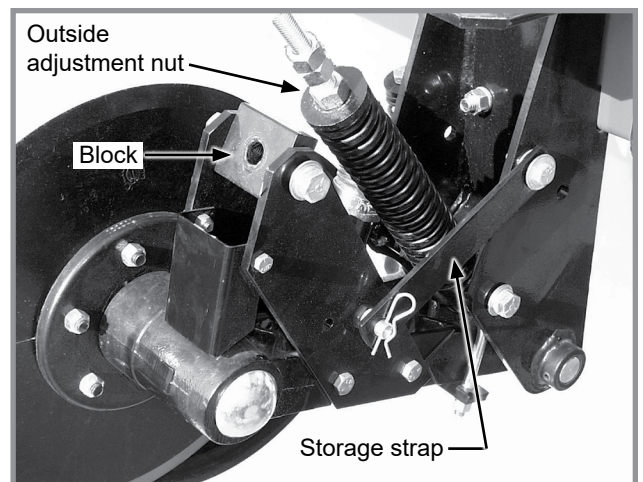

LIQUID FERTILIZER ATTACHMENT**WARNING**

Agricultural chemicals can cause death or serious injury to persons, animals, and plants or seriously damage soil, equipment, or property. Read and follow all chemical and equipment manufacturers labels and instructions.

**CAUTION**

Overfilling tank can cause siphoning, tank collapse, personal injury, and damage to property and equipment. Do not overfill tank. Do not leave planter unattended when filling tank. Close fill valve and open tank lid if siphoning occurs. Follow all chemical manufacturers first aid, cleanup, and handling instructions.



Liquid fertilizer option installed

NOTICE

Placing fertilizer too close to seeds or in excessive amounts can cause germination or seedling damage. Check with your fertilizer dealer or manufacturer for correct amount and placement.



Repairable check valve

Optional low rate check valves are available for in-line installation between liquid fertilizer squeeze or piston pump and openers to ensure equal distribution of product at low rates. Check valves also eliminate anti-siphon loops.

OPTIONAL PISTON PUMP

NOTE: Keep manuals shipped with pump and flow divider with this manual.

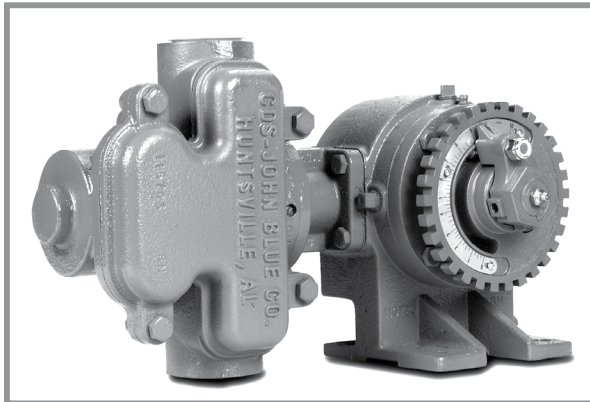

Piston pump

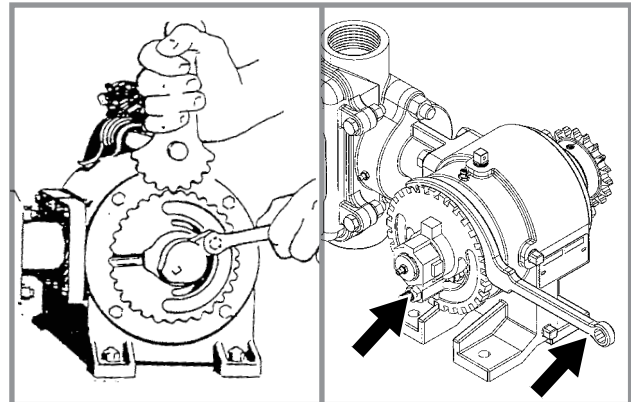

Adjusting delivery rate

NOTE: Delivery rate chart in Rate Chart section of this manual provides approximate application rate only. Delivery varies with temperature and fertilizer.

Loosen $\frac{3}{8}$ " lock nut that secures arm with pointer and rotate scale flange with adjustment wrench until pointer is over desired scale setting. Tighten $\frac{3}{8}$ " lock nut. DO NOT OVERTIGHTEN.

NOTE: Periodically check flow to all rows. Set rate is delivered to remaining rows if one or more lines are plugged.

CLEANING

Clean tanks, hoses, and metering pump thoroughly with water at end of planting season or prior to an extended period of non-use. Do not allow fertilizer to crystallize from cold temperature or evaporation.

On machines equipped with piston pump, take apart and clean strainer located between piston pump and ball valve daily. Remove the end cap to clean the screen. See Piston Pump Storage in Maintenance Section of this manual.

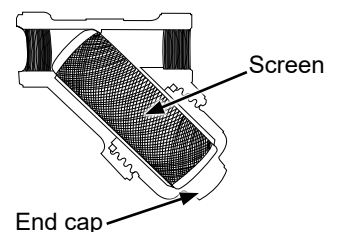

GENERAL PLANTING RATE INFORMATION

These planting rate charts are applicable to Kinze Model 3205 70 cm Planters.

NOTICE

Sprocket combinations in these charts are for average conditions. Changes in sprocket combinations may be required for desired planting population. **ALWAYS MAKE FIELD CHECKS TO BE SURE YOU ARE PLANTING AT THE DESIRED RATE.**

NOTICE

Seed additives added in the hopper may affect finger pickup seed meter performance and accelerate wear.

NOTE: Seed size and shape may affect planting rate.

NOTE: Not all row spacings listed apply to all size planters.

NOTE: Speeds above 9 km/h can adversely affect seed spacing.

MECHANICAL SEED METERING

Finger Pickup Corn Meter

Larger grades generally plant more accurately at the high end of the ground speed range than smaller grades. Higher than optimum speeds may result in population rate increase or higher incidence of doubles, particularly with small seed. Medium round corn seed is most desirable for planting accuracy at optimum speed.

Finger Pickup Oil Sunflower Meter

Larger grades generally plant more accurately at the high end of the ground speed range than smaller grades. Higher than optimum speeds may result in population rate increase or higher incidence of doubles, particularly with small seed. No. 3 and/or No. 4 size oil sunflower seeds are recommended for use in finger pickup seed meters equipped with oil sunflower fingers. No. 1 and/or No. 2 size confectionery sunflower seeds are recommended for use in finger pickup seed meters equipped with corn fingers.

Brush-Type Seed Meter (Soybean, Milo/Grain Sorghum, Acid-Delinted Cotton)

Rate charts are given in seeds per hectare as well as seed spacing in inches rounded to the nearest tenth of an inch. Because of the large range in seed size, kilograms per hectare is not a suggested method of selecting transmission settings. Smaller size seed kilograms per hectare may be below what was expected and large seed kilograms per hectare may appear above expectations. To determine kilograms per hectare, use the formula given in "Determining Pounds Per Acre (Brush-Type Seed Meter)" in "Check Seed Population" in Machine Operation section of this manual.

NOTE: Planting speed can affect actual seeding rate. Make a field check and adjust transmission setting to obtain desired seed drop.

Standard Rate (1 To 1) 30 Tooth Drive Sprocket

When planting 70cm rows with brush-type seed meters using 30 tooth standard rate (1 to 1) sprocket, use charts on page 5-2 to 5-5.

Half Rate (2 To 1) 15 Tooth Drive Sprocket

When using 15 tooth half rate (2 to 1) sprocket with brush-type seed meters, seeding rate is approximately 50% of chart readings.

NOTE: Use of the Half Rate (2 To 1) Drive Reduction Package with brush-type seed meters will reduce planter transmission speed. Seeding rate will be approximately 50% of the chart reading when using Half Rate (2 To 1) Drive Reduction Package.

EXAMPLE: 70cm row spacing using 60 cell seed discs in brush-type seed meters.
 $80,928 \div 2 = 40,464$ Population (6.5cm Seed Spacing x 2 = 13cm Seed Spacing)

VACUUM SEED METERING

NOTE: Seed size and shape may affect planting rate.

NOTE: Speeds above 10.0 km/h can adversely affect seed spacing.

NOTE: Planting rates above 672,500 seeds/hectare is not recommended.

**PLANTING RATES FOR FINGER PICKUP SEED METERS (STANDARD DRIVE)
APPROXIMATE SEEDS/HECTARE FOR 70 CM ROW WIDTHS**

70cm Rows	Transmission Sprockets		Recomm. Speed Range (km/h)	Average Seed Spacing In Centimeters
	Drive	Driven		
43,539	17	28	6 to 10	32.8
45,150	17	27	6 to 10	31.8
46,888	17	26	6 to 10	30.5
48,661	19	28	6 to 10	29.5
48,763	17	25	6 to 10	29.2
50,463	19	27	6 to 10	28.2
50,794	17	24	6 to 10	28.2
52,402	19	26	6 to 10	27.2
53,002	17	23	6 to 10	26.9
54,500	19	25	6 to 10	26.2
56,768	19	24	6 to 10	25.1
58,904	23	28	6 to 10	24.1
59,237	19	23	6 to 10	24.1
61,085	23	27	6 to 10	23.4
61,465	24	28	6 to 10	23.4
63,436	23	26	6 to 10	22.6
63,743	24	27	6 to 10	22.4
64,025	25	28	6 to 10	22.4
64,163	17	19	6 to 10	22.4
65,973	23	25	6 to 10	21.6
66,193	24	26	6 to 10	21.6
66,398	25	27	6 to 10	21.6
66,589	26	28	6 to 10	21.3
68,722	23	24	6 to 10	20.8
68,840	24	25	6 to 10	20.8
68,951	25	26	6 to 10	20.8
69,053	26	27	6 to 10	20.6
69,150	27	28	6 to 10	20.6
71,710	23	23	6 to 10	19.8
74,365	28	27	6 to 10	19.3
74,468	27	26	6 to 10	19.3
74,699	25	24	6 to 10	19.1
74,828	24	23	6 to 10	19.1
77,225	28	26	6 to 10	18.5
77,445	27	25	6 to 10	18.5
77,946	25	23	6 to 10	18.3
80,146	19	17	6 to 10	17.8
80,315	28	25	6 to 10	17.8
80,673	27	24	6 to 10	17.8
81,063	26	23	6 to 10	17.8
83,662	28	24	5 to 10	17.0
84,181	27	23	5 to 10	17.0
86,806	23	19	5 to 9	16.5
87,299	28	23	5 to 9	16.5
90,580	24	19	5 to 9	15.7
94,354	25	19	5 to 8	15.2
97,020	23	17	5 to 8	14.7
98,128	26	19	5 to 8	14.5
101,238	24	17	5 to 8	14.2
101,902	27	19	5 to 8	14.0
105,455	25	17	5 to 7	13.5
105,679	28	19	5 to 7	13.5
109,673	26	17	5 to 7	13.0
113,891	27	17	5 to 7	12.4
118,109	28	17	5 to 7	12.2

NOTE: See “General Planting Rate Information” and “Check Seed Population” pages for more information. Always field check seed population to verify planting rates.

**PLANTING RATES FOR BRUSH-TYPE SEED METERS (STANDARD DRIVE)
APPROXIMATE SEEDS/HECTARE FOR 70 CM ROW WIDTHS**

Transmission Sprockets		60 Cell Soybean Or High-Rate Milo/ Grain Sorghum	Average Seed Spacing In Centimeters	48 Cell Specialty Soybean Or High-Rate Acid-Delinted Cotton	Average Seed Spacing In Centimeters	Speed Range (km/h)
Drive	Driven					
		70cm Rows		70cm Rows		
17	28	217,689	6.6	174,150	8.1	3 to 13
17	27	225,754	6.4	180,604	7.9	3 to 13
17	26	234,437	6.1	187,549	7.6	3 to 13
19	28	243,300	5.8	194,640	7.4	3 to 13
19	27	252,311	5.6	201,849	7.1	3 to 13
17	24	253,971	5.6	203,177	7.1	3 to 13
17	23	265,013	5.3	212,011	6.9	3 to 13
19	25	272,496	5.3	217,996	6.6	3 to 13
19	24	283,851	5.1	227,080	6.4	3 to 13
23	28	294,521	4.8	235,618	6.1	3 to 13
19	23	296,192	4.8	236,955	6.1	3 to 13
24	28	307,328	4.6	245,864	5.8	3 to 13
24	27	318,709	4.6	254,966	5.6	3 to 13
17	19	320,807	4.6	256,645	5.6	3 to 13
24	26	330,967	4.3	264,774	5.3	3 to 13
26	28	332,939	4.3	266,350	5.3	3 to 13
24	25	344,207	4.1	275,367	5.1	3 to 13
26	27	345,269	4.1	276,217	5.1	3 to 13
23	23	358,550	4.1	286,839	5.1	3 to 13
27	26	372,338	3.8	297,870	4.8	3 to 13
24	23	374,138	3.8	299,310	4.8	3 to 13
25	23	389,726	3.6	311,780	4.6	3 to 13
19	17	400,730	3.6	320,584	4.6	3 to 13
27	24	403,366	3.6	322,693	4.3	3 to 13
28	24	418,306	3.3	334,644	4.3	3 to 13
23	19	434,031	3.3	347,225	4.1	3 to 13
28	23	436,493	3.3	349,194	4.1	3 to 13
24	19	452,904	3.0	362,321	4.1	3 to 13
25	19	471,773	3.0	377,419	3.8	3 to 13
23	17	485,094	3.0	388,074	3.8	3 to 13
26	19	490,646	2.8	392,518	3.6	3 to 11
27	19	509,516	2.8	407,614	3.6	3 to 11
28	19	528,388	2.8	422,709	3.3	3 to 11
26	17	548,369	2.5	438,696	3.3	3 to 11
27	17	569,460	2.3	455,569	3.0	3 to 11
28	17	590,549	2.3	472,441	3.0	3 to 11

NOTE: See “General Planting Rate Information” and “Check Seed Population” pages for additional information.

NOTE: When using the Half Rate (2 To 1) Drive Reduction Package, rates will be approximately 50% of given numbers.

NOTE: Always field check seed population in the field to ensure planting rates are correct.

**PLANTING RATES FOR BRUSH-TYPE SEED METERS (STANDARD DRIVE)
APPROXIMATE SEEDS/HECTARE FOR 70 CM ROW WIDTHS**

Transmission Sprockets		36 Cell Acid-Delinted Large Cotton	Average Seed Spacing In Centimeters	30 Cell Milo/Grain Sorghum Or Acid-Delinted Cotton	Average Seed Spacing In Centimeters	Speed Range (km/h)
Drive	Drive	70cm Rows		70cm Rows		
17	28	130,614	10.9	108,845	10.9	3 to 13
17	27	135,453	10.7	112,877	10.7	3 to 13
17	26	140,661	10.2	117,218	10.2	3 to 13
19	28	145,979	9.9	121,651	9.9	3 to 13
19	27	151,386	9.4	126,157	9.4	3 to 13
17	24	152,384	9.4	126,986	9.4	3 to 13
17	23	159,009	8.9	132,508	8.9	3 to 13
19	25	163,498	8.6	136,250	8.6	3 to 13
19	24	170,309	8.4	141,925	8.4	3 to 13
23	28	176,714	8.1	147,262	8.1	3 to 13
19	23	177,715	8.1	148,096	8.1	3 to 13
24	28	184,396	7.6	153,664	7.6	3 to 13
24	27	191,226	7.4	159,356	7.4	3 to 13
17	19	192,485	7.4	160,402	7.4	3 to 13
24	26	198,580	7.1	165,484	7.1	3 to 13
26	28	199,764	7.1	166,468	7.1	3 to 13
24	25	206,510	6.9	172,103	6.9	3 to 13
26	27	207,161	6.9	172,633	6.9	3 to 13
23	23	215,129	6.6	179,275	6.6	3 to 13
27	26	223,403	6.4	186,169	6.4	3 to 13
24	23	224,481	6.4	187,067	6.4	3 to 13
25	23	233,834	6.1	194,863	6.1	3 to 13
19	17	240,438	5.8	200,366	5.8	3 to 13
27	24	242,020	5.8	201,684	5.8	3 to 13
28	24	250,983	5.6	209,154	5.6	3 to 13
23	19	260,419	5.6	217,017	5.6	3 to 13
28	23	261,896	5.3	218,246	5.3	3 to 13
24	19	271,743	5.3	226,450	5.3	3 to 13
25	19	283,065	5.1	235,887	5.1	3 to 13
23	17	291,138	4.8	242,547	4.8	3 to 13
26	19	294,387	4.8	245,323	4.8	3 to 11
27	19	305,709	4.6	254,759	4.6	3 to 11
28	19	317,033	4.6	264,193	4.6	3 to 11
26	17	329,022	4.3	274,183	4.3	3 to 11
27	17	341,676	4.1	284,730	4.1	3 to 11
28	17	354,329	4.1	295,275	4.1	3 to 11

NOTE: See “General Planting Rate Information” and “Check Seed Population” pages for more information.
NOTE: Rates are approximately 50% of given numbers when using Half Rate (2 To 1) Drive Reduction Package.
NOTE: Always field check seed population to verify planting rates.

**PLANTING RATES FOR BRUSH-TYPE SEED METERS (STANDARD DRIVE)
APPROXIMATE SEEDS/HECTARE FOR 70 CM ROW WIDTHS**

Due to variations in cotton seed size, meters equipped with the 12 cell acid-delinted hill-drop cotton discs will plant from 3 to 6 seeds per cell. Select proper disc for seed size range to be planted.

To determine planter transmission setting, determine desired hill spacing and select the transmission ratio closest to the hill spacing in inches on the chart. To decrease population increase spacing. To increase population decrease spacing.

To determine population per hectare, determine average seeds per hill and hills per hectare by doing a field check. Measure 1/1000 of an hectare (1/1000 hectare = Length of row 14.28m for 70cm row widths. Multiply average seeds per hill by hills per hectare. EXAMPLE: 4 seeds per hill x (13 hills x 1000) = 52,000.

Transmission Sprockets		NUMBER OF HILLS PER HECTARE 12 Cell Hill-Drop Cotton, Acid-Delinted 70cm Rows	Average Hill Spacing In Centimeters	Speed Range (km/h)
Drive	Drive			
17	28	43,539	32.8	3 to 13
17	27	45,150	31.8	3 to 13
17	26	46,888	30.5	3 to 13
19	28	48,661	29.5	3 to 13
19	27	50,463	28.2	3 to 13
17	24	50,794	28.2	3 to 13
17	23	53,002	26.9	3 to 13
19	25	54,500	26.2	3 to 13
19	24	56,771	25.1	3 to 13
23	28	58,904	24.1	3 to 13
19	23	59,237	24.1	3 to 13
24	28	61,465	23.4	3 to 13
24	27	63,743	22.4	3 to 13
17	19	64,163	22.4	3 to 13
24	26	66,193	21.6	3 to 13
26	28	66,589	21.3	3 to 13
24	25	68,840	20.8	3 to 13
26	27	69,053	20.6	3 to 13
23	23	71,710	19.8	3 to 13
27	26	74,468	19.3	3 to 13
24	23	74,828	19.1	3 to 13
25	23	77,946	18.3	3 to 13
19	17	80,146	17.8	3 to 13
27	24	80,673	17.8	3 to 13
28	24	83,662	17.0	3 to 13
23	19	86,806	16.5	3 to 13
28	23	87,299	16.5	3 to 13
24	19	90,580	15.7	3 to 13
25	19	94,354	15.2	3 to 13
23	17	97,020	14.7	3 to 13
26	19	98,128	14.5	3 to 11
27	19	101,902	14.0	3 to 11
28	19	105,679	13.5	3 to 11
26	17	109,673	13.0	3 to 11
27	17	113,891	12.4	3 to 11
28	17	118,109	12.2	3 to 11

NOTE: See “General Planting Rate Information” and “Check Seed Population” pages for more information.

NOTE: Rates are approximately 50% of given numbers when using Half Rate (2 To 1) Drive Reduction Package.

NOTE: Always field check seed population to verify planting rates.

**PLANTING RATES FOR VACCUM METER CORN/SUNFLOWER 40 CELL DISC
15 TOOTH CONTACT WHEEL SPROCKET
APPROXIMATE SEEDS/HECTARE FOR VARIOUS ROW WIDTHS**

70 cm Rows (Seeds/Hectare)	Transmission Sprock- ets		Recomm. Speed (km/h)	Average Spacing (cm)
	Drive	Driven		
68335	15	28	6 to 10	20.9
70865	15	27	6 to 10	20.2
73587	15	26	6 to 10	19.4
76553	15	25	6 to 10	18.7
77444	17	28	6 to 10	18.4
79724	15	24	6 to 10	17.9
80312	17	27	6 to 10	17.8
83188	15	23	6 to 10	17.2
83403	17	26	6 to 10	17.1
86556	19	28	6 to 10	16.5
86739	17	25	6 to 10	16.5
89763	19	27	6 to 10	15.9
90351	17	24	6 to 10	15.8
93214	19	26	6 to 10	15.3
94281	17	23	6 to 10	15.2
96942	19	25	6 to 10	14.7
100702	15	19	6 to 10	14.2
100982	19	24	6 to 10	14.1
104780	23	28	6 to 10	13.6
105371	19	23	6 to 10	13.6
108658	23	27	6 to 10	13.1
109333	24	28	6 to 10	13.1
112550	15	17	6 to 10	12.7
113383	24	27	6 to 10	12.6
114131	17	19	6 to 10	12.5
117353	23	25	6 to 10	12.2
118445	26	28	6 to 10	12.1
122240	23	24	6 to 10	11.7
122452	24	25	6 to 10	11.7
123001	27	28	6 to 10	11.6
127554	23	23	6 to 10	11.2
132279	28	27	6 to 10	10.8
132462	27	26	6 to 10	10.8
133101	24	23	6 to 10	10.7
137370	28	26	6 to 10	10.4
137759	27	25	6 to 10	10.4
138649	25	23	6 to 10	10.3
142563	19	17	6 to 10	10.0
143501	27	24	6 to 10	10.0
144194	26	23	6 to 10	9.9
148814	28	24	6 to 10	9.6
149739	27	23	6 to 10	9.5
154408	23	19	6 to 10	9.3
155284	28	23	6 to 10	9.2
161125	24	19	6 to 10	8.9
167836	25	19	6 to 10	8.5
172575	23	17	6 to 10	8.3
174550	26	19	6 to 10	8.2
180079	24	17	6 to 10	7.9
181265	27	19	6 to 10	7.9
187584	25	17	6 to 10	7.6
187976	28	19	6 to 10	7.6
195085	26	17	6 to 10	7.3
195585	23	15	6 to 10	7.3
202587	27	17	6 to 10	7.1

**PLANTING RATES FOR VACCUM METER CORN/SUNFLOWER 40 CELL DISC
19 TOOTH CONTACT WHEEL SPROCKET**

APPROXIMATE SEEDS/HECTARE FOR VARIOUS ROW WIDTHS

70 cm Rows (Seeds/Hectare)	Transmission Sprockets		Recomm. Speed (km/h)	Average Spacing (cm)
	Drive	Driven		
86556	15	28	6 to 10	16.5
89763	15	27	6 to 10	15.9
93214	15	26	6 to 10	15.3
96942	15	25	6 to 10	14.7
98095	17	28	6 to 10	14.6
100982	15	24	6 to 10	14.1
101729	17	27	6 to 10	14.0
105371	15	23	6 to 10	13.6
105642	17	26	6 to 10	13.5
109637	19	28	6 to 10	13.0
109868	17	25	6 to 10	13.0
113698	19	27	6 to 10	12.6
114445	17	24	6 to 10	12.5
118071	19	26	6 to 10	12.1
119423	17	23	6 to 10	12.0
122794	19	25	6 to 10	11.6
127554	15	19	6 to 10	11.2
127911	19	24	6 to 10	11.2
132717	23	28	6 to 10	10.8
133470	19	23	6 to 10	10.7
137633	23	27	6 to 10	10.4
138488	24	28	6 to 10	10.3
142563	15	17	6 to 10	10.0
143619	24	27	6 to 10	9.9
144565	17	19	6 to 10	9.9
148645	23	25	6 to 10	9.6
150029	26	28	6 to 10	9.5
154838	23	24	6 to 10	9.2
155109	24	25	6 to 10	9.2
155800	27	28	6 to 10	9.2
161571	23	23	6 to 10	8.8
167554	28	27	6 to 10	8.5
167785	27	26	6 to 10	8.5
168594	24	23	6 to 10	8.5
173997	28	26	6 to 10	8.2
174497	27	25	6 to 10	8.2
175617	25	23	6 to 10	8.1
180579	19	17	6 to 10	7.9
181767	27	24	6 to 10	7.9
182646	26	23	6 to 10	7.8
188498	28	24	6 to 10	7.6
189669	27	23	6 to 10	7.5
195585	23	19	6 to 10	7.3
196693	28	23	6 to 10	7.3
204087	24	19	6 to 10	7.0
212591	25	19	6 to 10	6.7
218596	23	17	6 to 10	6.5
221096	26	19	6 to 10	6.5
228100	24	17	6 to 10	6.3
229603	27	19	6 to 10	6.2
237604	25	17	6 to 10	6.0
238104	28	19	6 to 10	6.0
247106	26	17	6 to 10	5.8
247740	23	15	6 to 10	5.8
256613	27	17	6 to 10	5.6

**PLANTING RATES FOR VACUUM METER SOYBEANS 120 CELL DISC
15 TOOTH CONTACT WHEEL SPROCKET
APPROXIMATE SEEDS/HECTARE FOR VARIOUS WIDTHS**

70 cm Rows (Seeds/Hectare)	Transmission Sprockets		Recomm. Speed (km/h)	Average Spacing (cm)
	Drive	Driven		
205001	15	28	6 to 10	7.0
212594	15	27	6 to 10	6.7
220770	15	26	6 to 10	6.5
229600	15	25	6 to 10	6.2
232333	17	28	6 to 10	6.1
239166	15	24	6 to 10	6.0
240937	17	27	6 to 10	5.9
249565	15	23	6 to 10	5.7
250205	17	26	6 to 10	5.7
259666	19	28	6 to 10	5.5
260214	17	25	6 to 10	5.5
269283	19	27	6 to 10	5.3
271057	17	24	6 to 10	5.3
279642	19	26	6 to 10	5.1
282840	17	23	6 to 10	5.1
290826	19	25	6 to 10	4.9
302104	15	19	6 to 10	4.7
302945	19	24	6 to 10	4.7
314334	23	28	6 to 10	4.5
316116	19	23	6 to 10	4.5
325975	23	27	6 to 10	4.4
328001	24	28	6 to 10	4.4
337648	15	17	6 to 10	4.2
340148	24	27	6 to 10	4.2
342387	17	19	6 to 10	4.2
352055	23	25	6 to 10	4.1
355334	26	28	6 to 10	4.0
366722	23	24	6 to 10	3.9
367359	24	25	6 to 10	3.9
369002	27	28	6 to 10	3.9
382666	23	23	6 to 10	3.7
396839	28	27	6 to 10	3.6
397385	27	26	6 to 10	3.6
399304	24	23	6 to 10	3.6
412104	28	26	6 to 10	3.5
413281	27	25	6 to 10	3.5
415942	25	23	6 to 10	3.4
427688	19	17	6 to 10	3.3
430499	27	24	6 to 10	3.3
432579	26	23	6 to 10	3.3
446446	28	24	6 to 10	3.2
449217	27	23	6 to 10	3.2
463229	23	19	6 to 10	3.1
465855	28	23	6 to 10	3.1
483369	24	19	6 to 10	3.0
503509	25	19	6 to 10	2.8
517725	23	17	6 to 10	2.8
523649	26	19	6 to 10	2.7
540235	24	17	6 to 10	2.6
543788	27	19	6 to 10	2.6
562746	25	17	6 to 10	2.5
563931	28	19	6 to 10	2.5
585256	26	17	6 to 10	2.4
586756	23	15	6 to 10	2.4
607764	27	17	6 to 10	2.4

**PLANTING RATES FOR VACUUM METER SOYBEANS 120 CELL DISC
19 TOOTH CONTACT WHEEL SPROCKET
APPROXIMATE SEEDS/HECTARE FOR VARIOUS WIDTHS**

70 cm Rows (Seeds/Hectare)	Transmission Sprockets		Recomm. Speed (km/h)	Average Spacing (cm)
	Drive	Driven		
259666	15	28	6 to 10	7.0
269283	15	27	6 to 10	6.7
279642	15	26	6 to 10	6.5
290826	15	25	6 to 10	6.2
294826	17	28	6 to 10	6.1
302945	15	24	6 to 10	6.0
305190	17	27	6 to 10	5.9
316116	15	23	6 to 10	5.7
316927	17	26	6 to 10	5.7
328913	19	28	6 to 10	5.5
329603	17	25	6 to 10	5.5
341094	19	27	6 to 10	5.3
343338	17	24	6 to 10	5.3
354213	19	26	6 to 10	5.1
358264	17	23	6 to 10	5.1
368381	19	25	6 to 10	4.9
382666	15	19	6 to 10	4.7
383731	19	24	6 to 10	4.7
398156	23	28	6 to 10	4.5
400414	19	23	6 to 10	4.5
412902	23	27	6 to 10	4.4
415466	24	28	6 to 10	4.4
427688	15	17	6 to 10	4.2
430854	24	27	6 to 10	4.2
433690	17	19	6 to 10	4.2
445935	23	25	6 to 10	4.1
450088	26	28	6 to 10	4.0
464516	23	24	6 to 10	3.9
465323	24	25	6 to 10	3.9
467400	27	28	6 to 10	3.9
484713	23	23	6 to 10	3.7
502665	28	27	6 to 10	3.6
503355	27	26	6 to 10	3.6
505785	24	23	6 to 10	3.6
521996	28	26	6 to 10	3.5
523487	27	25	6 to 10	3.5
526861	25	23	6 to 10	3.4
541735	19	17	6 to 10	3.3
545299	27	24	6 to 10	3.3
547936	26	23	6 to 10	3.3
565495	28	24	6 to 10	3.2
569008	27	23	6 to 10	3.2
586756	23	19	6 to 10	3.1
590084	28	23	6 to 10	3.1
612266	24	19	6 to 10	3.0
637779	25	19	6 to 10	2.8
655785	23	17	6 to 10	2.8
663289	26	19	6 to 10	2.7

**PLANTING RATES FOR VACUUM METER MILO/SUGAR BEET/SPECIALTY 60 CELL DISC
15 TOOTH CONTACT WHEEL SPROCKET
APPROXIMATE SEEDS/HECTARE FOR VARIOUS WIDTHS**

70 cm Rows (Seeds/Hectare)	Transmission Sprockets		Recomm. Speed (km/h)	Average Spacing (cm)
	Drive	Driven		
102500	15	28	6 to 10	13.9
106296	15	27	6 to 10	13.4
110384	15	26	6 to 10	12.9
114800	15	25	6 to 10	12.4
116168	17	28	6 to 10	12.3
119584	15	24	6 to 10	11.9
120469	17	27	6 to 10	11.9
124783	15	23	6 to 10	11.4
125102	17	26	6 to 10	11.4
129833	19	28	6 to 10	11.0
130107	17	25	6 to 10	11.0
134642	19	27	6 to 10	10.6
135528	17	24	6 to 10	10.5
139821	19	26	6 to 10	10.2
141420	17	23	6 to 10	10.1
145414	19	25	6 to 10	9.8
151053	15	19	6 to 10	9.5
151473	19	24	6 to 10	9.4
157166	23	28	6 to 10	9.1
158058	19	23	6 to 10	9.0
162987	23	27	6 to 10	8.8
164001	24	28	6 to 10	8.7
168823	15	17	6 to 10	8.5
170075	24	27	6 to 10	8.4
171193	17	19	6 to 10	8.3
176026	23	25	6 to 10	8.1
177666	26	28	6 to 10	8.0
183361	23	24	6 to 10	7.8
183681	24	25	6 to 10	7.8
184501	27	28	6 to 10	7.7
191333	23	23	6 to 10	7.5
198421	28	27	6 to 10	7.2
198693	27	26	6 to 10	7.2
199652	24	23	6 to 10	7.2
206052	28	26	6 to 10	6.9
206640	27	25	6 to 10	6.9
207971	25	23	6 to 10	6.9
213844	19	17	6 to 10	6.7
215250	27	24	6 to 10	6.6
216290	26	23	6 to 10	6.6
223222	28	24	6 to 10	6.4
224609	27	23	6 to 10	6.4
231613	23	19	6 to 10	6.2
232927	28	23	6 to 10	6.1
241684	24	19	6 to 10	5.9
251756	25	19	6 to 10	5.7
258862	23	17	6 to 10	5.5
261824	26	19	6 to 10	5.5
270119	24	17	6 to 10	5.3
271896	27	19	6 to 10	5.3
281373	25	17	6 to 10	5.1
281964	28	19	6 to 10	5.1
292627	26	17	6 to 10	4.9
293377	23	15	6 to 10	4.9
303883	27	17	6 to 10	4.7

**PLANTING RATES FOR VACUUM METER MILO/SUGAR BEET/SPECIALTY 60 CELL DISC
19 TOOTH CONTACT WHEEL SPROCKET
APPROXIMATE SEEDS/HECTARE FOR VARIOUS WIDTHS**

70 cm Rows (Seeds/Hectare)	Transmission Sprockets		Recomm. Speed (km/h)	Average Spacing (cm)
	Drive	Driven		
129833	15	28	6 to 10	11.0
134642	15	27	6 to 10	10.6
139821	15	26	6 to 10	10.2
145414	15	25	6 to 10	9.8
147145	17	28	6 to 10	9.7
151473	15	24	6 to 10	9.4
152594	17	27	6 to 10	9.4
158058	15	23	6 to 10	9.0
158464	17	26	6 to 10	9.0
164455	19	28	6 to 10	8.7
164802	17	25	6 to 10	8.7
170546	19	27	6 to 10	8.4
171669	17	24	6 to 10	8.3
177107	19	26	6 to 10	8.1
179133	17	23	6 to 10	8.0
184192	19	25	6 to 10	7.8
191333	15	19	6 to 10	7.5
191865	19	24	6 to 10	7.4
199077	23	28	6 to 10	7.2
200206	19	23	6 to 10	7.1
206452	23	27	6 to 10	6.9
207734	24	28	6 to 10	6.9
213844	15	17	6 to 10	6.7
215427	24	27	6 to 10	6.6
216843	17	19	6 to 10	6.6
222966	23	25	6 to 10	6.4
225044	26	28	6 to 10	6.3
232258	23	24	6 to 10	6.2
232661	24	25	6 to 10	6.1
233699	27	28	6 to 10	6.1
242356	23	23	6 to 10	5.9
251331	28	27	6 to 10	5.7
251678	27	26	6 to 10	5.7
252893	24	23	6 to 10	5.6
260999	28	26	6 to 10	5.5
261744	27	25	6 to 10	5.5
263429	25	23	6 to 10	5.4
270869	19	17	6 to 10	5.3
272651	27	24	6 to 10	5.2
273968	26	23	6 to 10	5.2
282749	28	24	6 to 10	5.1
284504	27	23	6 to 10	5.0
293377	23	19	6 to 10	4.9
295040	28	23	6 to 10	4.8
306133	24	19	6 to 10	4.7
318890	25	19	6 to 10	4.5
327894	23	17	6 to 10	4.4
331643	26	19	6 to 10	4.3
342150	24	17	6 to 10	4.2
344400	27	19	6 to 10	4.1
356406	25	17	6 to 10	4.0
357156	28	19	6 to 10	4.0
370663	26	17	6 to 10	3.9
371611	23	15	6 to 10	3.8
384919	27	17	6 to 10	3.7

**PLANTING RATES FOR (VACUUM) RAPESEED 83 CELL DISC
15 TOOTH CONTACT WHEEL DRIVE SPROCKET
34 TOOTH SPROCKET HALF RATE KIT INSTALLED
APPROXIMATE SEEDS/HECTARE FOR 35 CM ROW WIDTHS**

35cm	Transmission Sprockets		Recomm. Speed (km/h)	Average Spacing (cm)
	Drive	Driven		
350596	25	24	6 to 10	8.1
351202	24	23	6 to 10	8.1
362453	28	26	6 to 10	7.9
363486	27	25	6 to 10	7.9
365835	25	23	6 to 10	7.8
376164	19	17	6 to 10	7.6
376957	28	25	6 to 10	7.6
378638	27	24	6 to 10	7.5
380468	26	23	6 to 10	7.5
392665	28	24	6 to 10	7.3
395101	27	23	6 to 10	7.2
407422	23	19	6 to 10	7.0
409734	28	23	6 to 10	7.0
425134	24	19	6 to 10	6.7
442847	25	19	6 to 10	6.5
455359	23	17	6 to 10	6.3
460559	26	19	6 to 10	6.2
475154	24	17	6 to 10	6.0
478275	27	19	6 to 10	6.0
494950	25	17	6 to 10	5.8
496000	28	19	6 to 10	5.8
514745	26	17	6 to 10	5.6
534545	27	17	6 to 10	5.3
554340	28	17	6 to 10	5.2

NOTE: See "General Planting Rate Information" and "Check Seed Population" pages for more information. Always field check seed population to verify planting rates.

**PLANTING RATES FOR (VACUUM) RAPESEED 83 CELL DISC
15 TOOTH CONTACT WHEEL DRIVE SPROCKET
17 TOOTH SPROCKET STANDARD RATE KIT INSTALLED
APPROXIMATE SEEDS/HECTARE FOR 35 CM ROW WIDTHS**

35cm	Transmission Sprockets		Recomm. Speed (km/h)	Average Spacing (cm)
	Drive	Driven		
360610	15*	28	6 to 10	7.9
373965	15*	27	6 to 10	7.6
381443	17	30*	6 to 10	7.5
388349	15*	26	6 to 10	7.4
403878	15*	25	6 to 10	7.1
408700	17	28	6 to 10	7.0
423823	17	27	6 to 10	6.7
440132	17	26	6 to 10	6.5
456774	19	28	6 to 10	6.3
457737	17	25	6 to 10	6.2
473689	19	27	6 to 10	6.0
476794	17	24	6 to 10	6.0
491900	19	26	6 to 10	5.8
497527	17	23	6 to 10	5.7
511587	19	25	6 to 10	5.6
532877	19	24	6 to 10	5.4
552929	23	28	6 to 10	5.2
556059	19	23	6 to 10	5.1
573406	23	27	6 to 10	5.0
576966	24	28	6 to 10	5.0
595475	23	26	6 to 10	4.8
598347	24	27	6 to 10	4.8
601003	25	28	6 to 10	4.8
602290	17	19	6 to 10	4.7
619280	23	25	6 to 10	4.6
621355	24	26	6 to 10	4.6
623272	25	27	6 to 10	4.6
625065	26	28	6 to 10	4.6
645084	23	24	6 to 10	4.4
646197	24	25	6 to 10	4.4
647234	25	26	6 to 10	4.4
648197	26	27	6 to 10	4.4
649102	27	28	6 to 10	4.4
673138	23	23	6 to 10	4.2
698063	28	27	6 to 10	4.1
699026	27	26	6 to 10	4.1
701192	25	24	6 to 10	4.1
702404	24	23	6 to 10	4.1
724905	28	26	6 to 10	3.9
726972	27	25	6 to 10	3.9
731670	25	23	6 to 10	3.9
752329	19	17	6 to 10	3.8
753914	28	25	6 to 10	3.8
757275	27	24	6 to 10	3.8
760936	26	23	6 to 10	3.8
785329	28	24	6 to 10	3.6
790202	27	23	6 to 10	3.6

NOTE: See "General Planting Rate Information" and "Check Seed Population" pages for more information. Always field check seed population to verify planting rates.

DRY INSECTICIDE APPLICATION RATES
APPROXIMATE KILOGRAMS/HECTARE AT 8 KM/H FOR 70 CM ROW WIDTHS

Meter Setting	70cm Rows
CLAY GRANULES	
10	5.5
11	6.1
12	6.8
13	7.7
14	8.6
15	9.5
16	10.8
17	12.0
18	12.8
19	14.7
20	15.9
21	17.4
22	18.4
23	19.3
24	21.1
25	23.4
26	25.8
27	27.0
28	28.5
29	31.2
30	33.2
SAND GRANULES	
5	3.3
6	5.5
7	5.9
8	7.1
9	8.7
10	10.0
11	11.4
12	12.6
13	14.1
14	15.8
15	17.4
16	19.6
17	21.7
18	24.4
19	27.2
20	28.8
21	30.9
22	33.2
23	35.9
24	38.6
25	41.4

NOTE: Chart represents average values and should be used only as a starting point. Granular chemical flows through meter opening at a nearly uniform rate regardless of roller speed. Your actual rate will vary depending on insecticide, planting speed, and plant population. Planting speed/ground speed has the greatest effect on application rate.

Field check your actual rate with insecticide you are using at speed and population you will be planting. See "Checking Granular Chemical Application Rate" in Machine Operation section for more information.

**DRY HERBICIDE APPLICATION RATES
APPROXIMATE KILOGRAMS/HECTARE AT 8 KM/H FOR 70 CM ROW WIDTHS
CLAY GRANULES**

Meter Setting	70cm Rows
10	5.3
11	5.8
12	6.5
13	7.3
14	8.2
15	9.2
16	10.1
17	11.1
18	12.0
19	13.0
20	14.1
21	15.2
22	16.4
23	17.6
24	19.1
25	20.3
26	21.7
27	23.4
28	25.3
29	27.2
30	29.9

NOTE: Chart represents average values and should be used only as a starting point. Granular chemical flows through given meter opening at a nearly uniform rate regardless of roller speed. Your actual rate will vary depending on specific herbicide, planting speed, and plant population. Planting speed/ground speed has the greatest effect on application rate.

Field check your actual rate with herbicide you are using at speed and population you will be planting. See "Granular Chemical Application Field Check" in Machine Operation section for more information.

LIQUID FERTILIZER PISTON PUMP APPLICATION RATES LITERS PER HECTARE**Applies To Model LM-2455-R And Model NGP-6055 Piston Pumps
With 18 Tooth Sprockets**

Pump Setting	2	3	4	5	6	7	8	9	10
12 Row 70cm	97.3	145.0	192.7	241.3	290.0	338.6	386.3	435.0	483.6

Chart is for planters equipped with contact drive. Check tires for correct operating pressure.

Chart calculated based on a solution weighing 1.2 kilograms per liter.

Chart is based on average wheel slippage and liquid viscosities.

Measure and weigh one gallon of actual fertilizer solution to determine exact application rate.

This chart was calculated based on a solution weighing ten pounds per gallon.

NOTE: Fertilizer application rates can vary from the above chart. To prevent application miscalculations, make field checks to be sure you are applying fertilizer to all rows at the desired rate.

NOTE: Periodically check flow to all rows. Desired rate is delivered to remaining rows keeping total application rate at desired rate if one or more lines are plugged.

To check the exact number of liters your fertilizer attachment will actually deliver on a 70 cm row spacing:

1. Remove hose from one fertilizer opener and insert it into a collection container secured planter frame.
2. Engage fertilizer attachment and drive forward for 143m.
3. Measure fluid milliliters caught in container. Result is liters of fertilizer delivered per hectare when planting in 70 cm rows (e.g. 20ml = 2 L ; 50ml= 5L; 100ml = 10L)
4. Rinse collection container and repeat test on other rows if necessary.

LUBRICATION

Following pages show locations of all lubrication points. Proper lubrication of moving parts helps ensure efficient operation of your Kinze planter and prolongs the life of friction producing parts.

WARNING

Uncontrolled machine can crush or cause loss of control resulting in death, serious injury, or damage to property and equipment. Install all safety lockup devices before working under or transporting equipment.

Lubrication Symbols

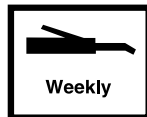
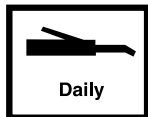

Lubricate at frequency indicated with an SAE multipurpose grease.

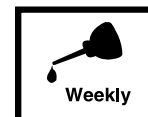

Lubricate at frequency indicated with a high quality SAE 10 W oil or a quality spray lubricant.

SEALED BEARINGS

Sealed bearings are used on your Kinze planter to provide trouble free operation.

These are located on drive shafts, row units, and transmission bearings. Sealed bearings are lubricated for life and not serviceable.

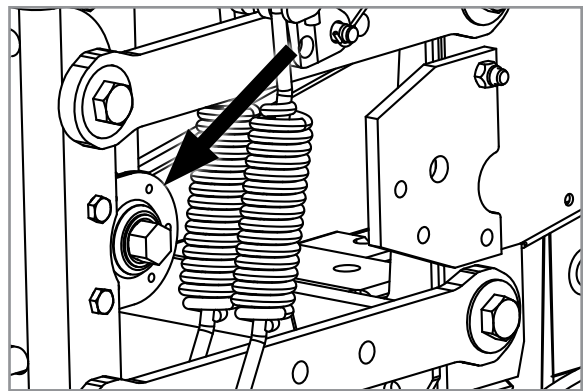

WRAP SPRING WRENCH ASSEMBLY

Components may require occasional lubrication to operate correctly. Disassembly is required to lubricate.

1. Remove 1/4"-20 x 1/2" cap screw that secures idler assembly to wrap spring wrench tightener shaft.
2. Remove wrap spring wrench from planter.
3. Tip wrap spring wrench on its side and lubricate with a high quality spray lubricant. Lubricant must be absorbed into wrap spring area.
4. Reinstall wrap spring wrench on planter.



Wrap Spring Wrench Lubrication

DRIVE CHAINS

Lubricate all transmission and drive chains daily with a high quality chain lubricant. Extreme operating conditions such as dirt, temperature, or speed may require more frequent lubrication. If a chain becomes stiff, it should be removed, soaked, and washed in solvent to loosen and remove dirt from joints. Soak chain in oil so lubricant can penetrate between rollers and bushings.

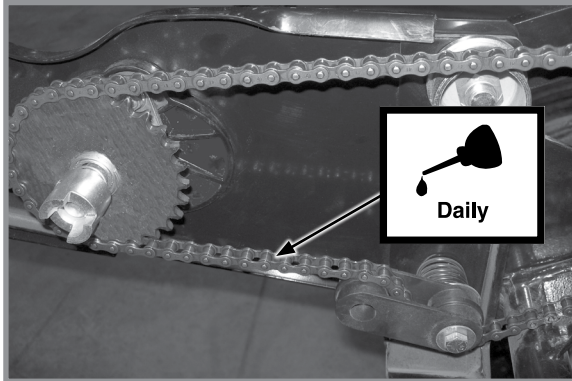

Row Unit Drive Chains

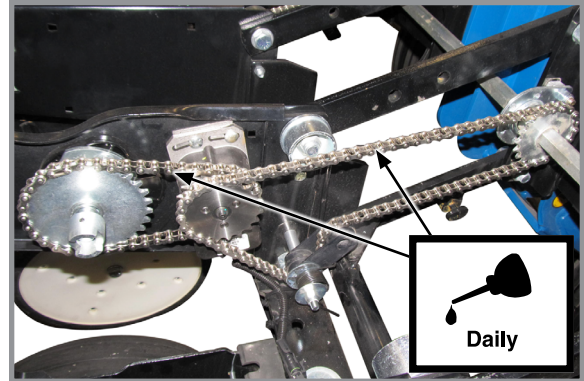

Row Unit Electric Clutches

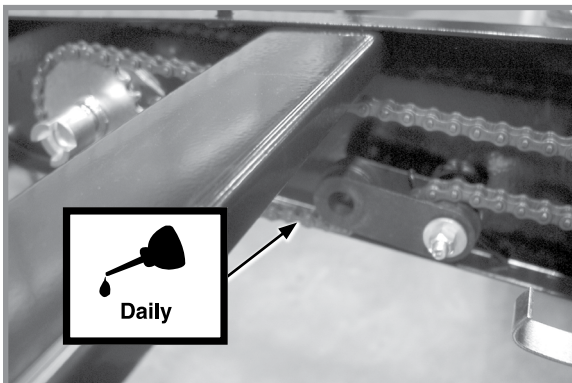

Row Unit Granular Chemical Drive Chains

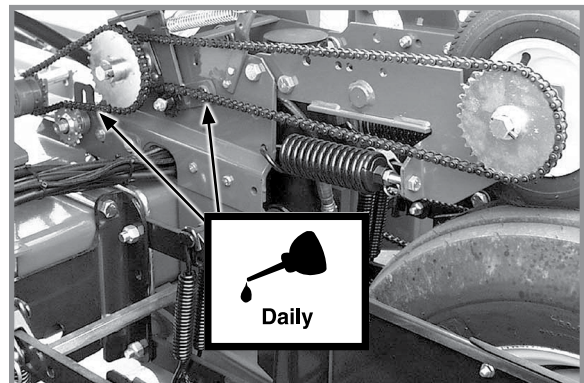

Liquid Fertilizer Piston Pump Drive Chains

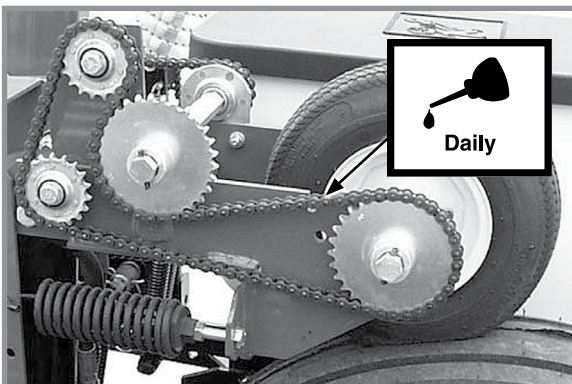

Contact Wheel Drive Chains

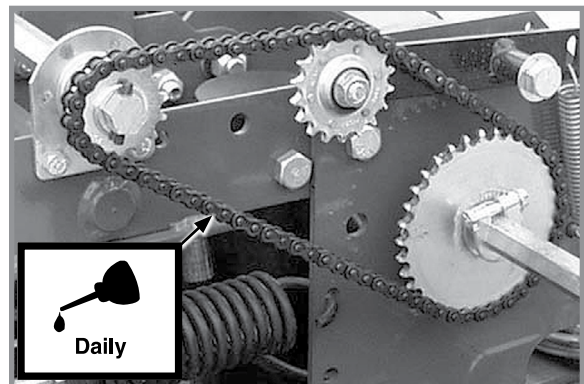

Jack Shaft (Reverser) Chains

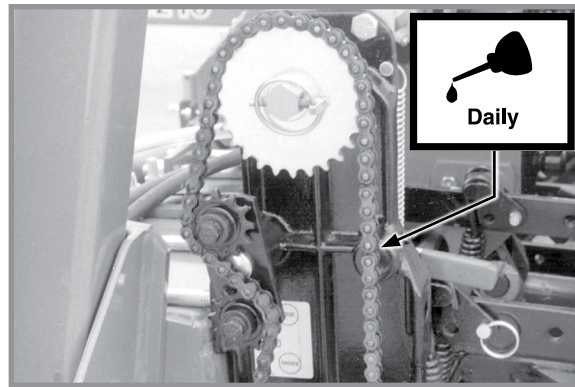

Seed Rate Transmission Chains

BUSHINGS

Lubricate bushings at frequency indicated.

Check each bolt for proper torque. If bolt is loose, removed it and inspect bushing for cracks and wear. Replace bushing if necessary. Use **only hardened flat washers**. Replace damaged flat washers with proper part. Torque hardware to 176 Nm.

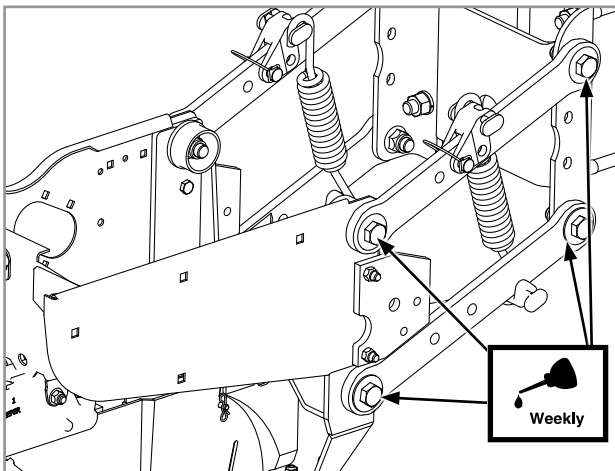

Pull row unit parallel linkages (8 per row)

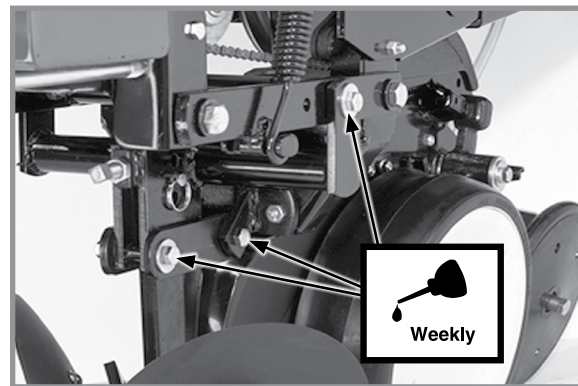

Row unit mounted disc furrower parallel linkages (6 per row)

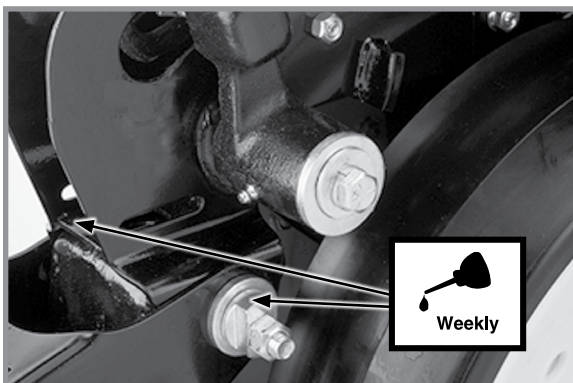

Row unit "v" closing wheel and/or drag closing wheel eccentric bushings (2 per row)

WHEEL BEARINGS

All drive, transport, and marker hub wheel bearings should be repacked annually and checked for wear.

1. Raise wheel off ground.
2. Check for bearing endplay by moving wheel side to side.
3. Rotate wheel to check for bearing roughness. If bearings sound rough, remove hub and inspect bearings.

NOTE: To repack wheel hubs, follow procedure outlined for wheel bearing replacement with exception that bearings and bearing cups are reused.

GREASE FITTINGS

Lubricate parts equipped with grease fittings at frequency indicated with an SAE multipurpose grease. Clean fitting thoroughly before using grease gun. Frequency of lubrication recommended is based on normal operating conditions. Severe or unusual conditions may require more frequent attention.

NOTE: Numbers on illustration below correspond to photos on following pages showing lubrication frequencies.

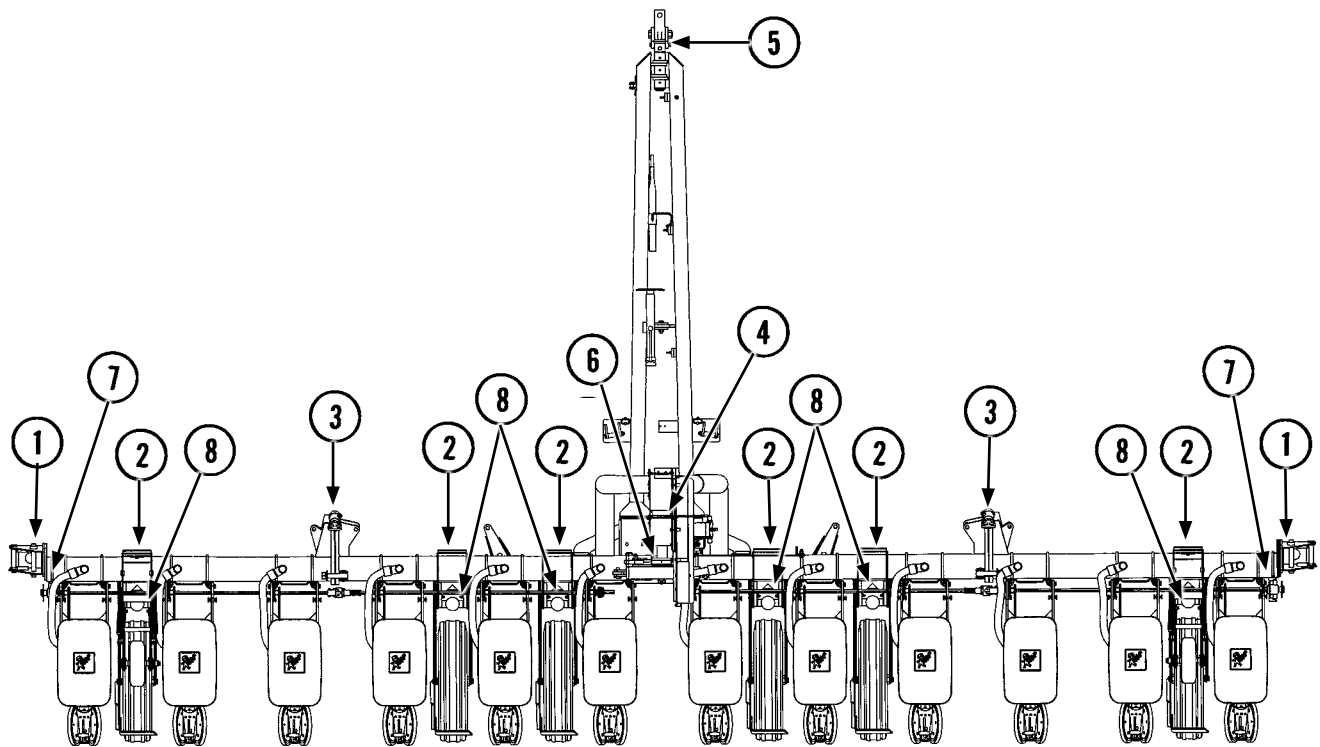

Model 3205 12 row planter shown

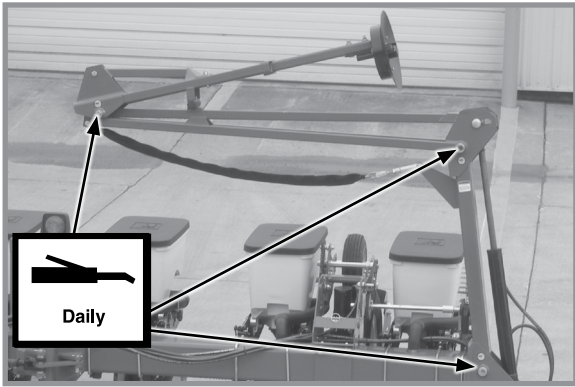

1. Row marker assemblies - 3 per assembly

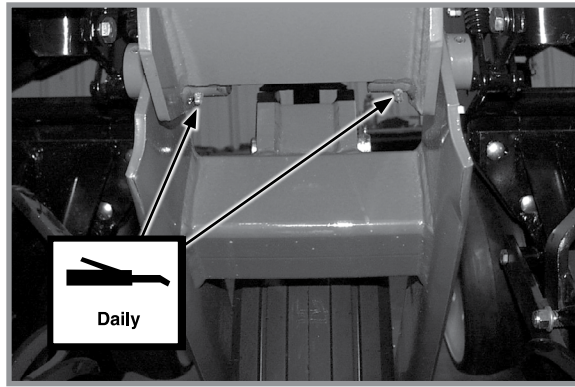

2. Wheel pivots - 2 per wheel module

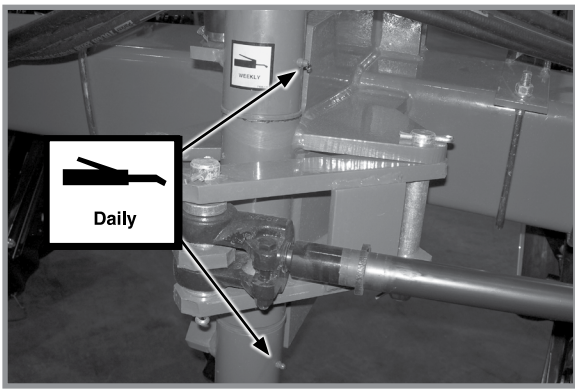

3. Wing hinges - 2 per wing

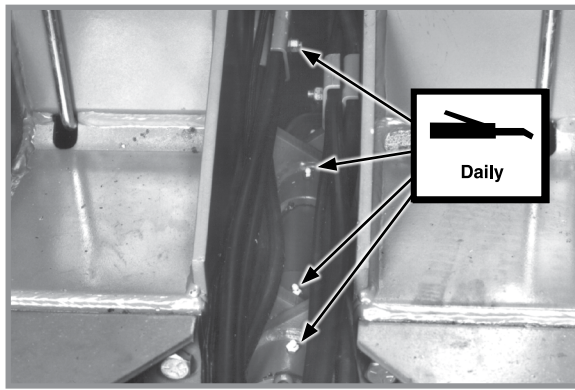

4. Center frame flex pin - 4

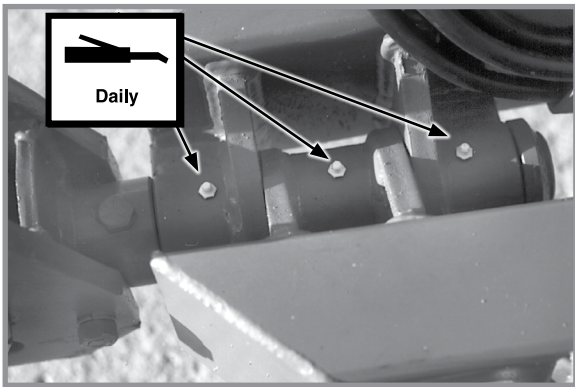

5. Hitch flex pin - 3

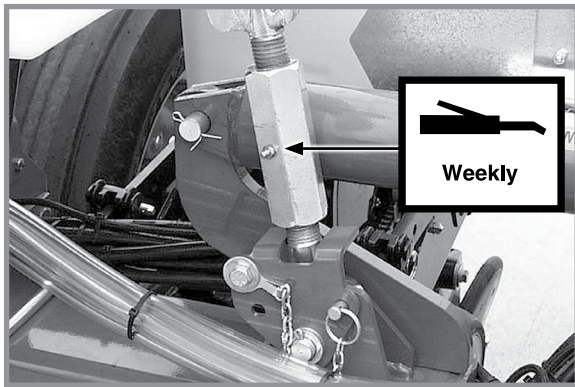

6. Turnbuckle - 1

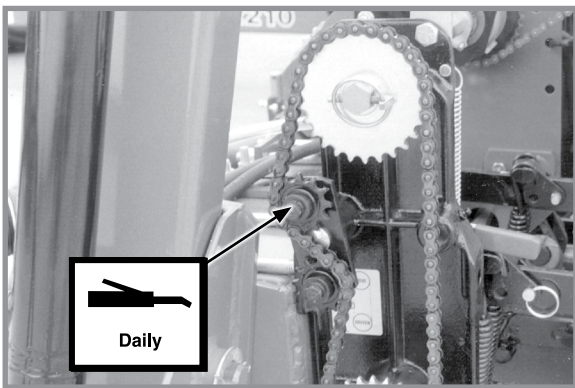

7. Seed rate transmission idler - 1 per transmission

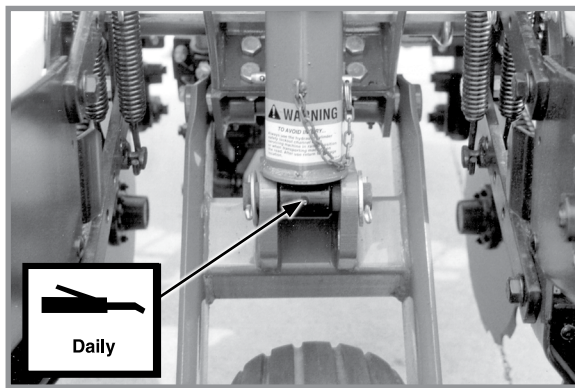

8. Planter lift cylinders (master, slave, and assist) - 1 per cylinder

FERTILIZER OPENERS

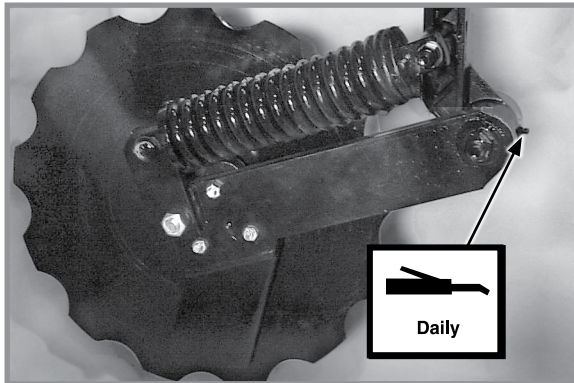

Notched single disc fertilizer opener - 1

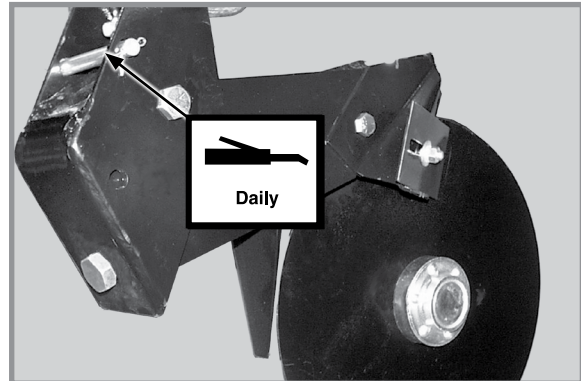

Double disc fertilizer opener - 1

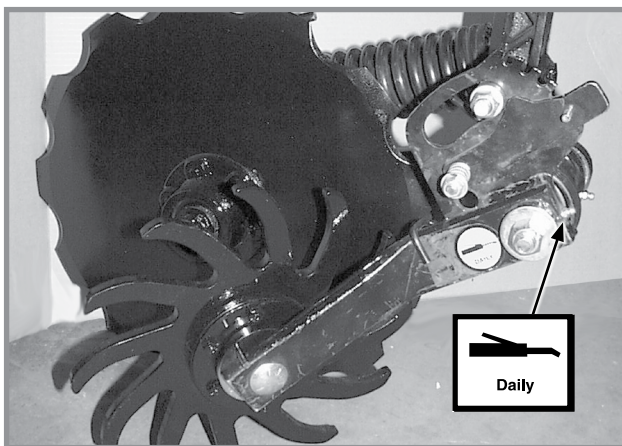

Residue Wheel Attachment For Use With Notched Single Disc Fertilizer Opener - 1

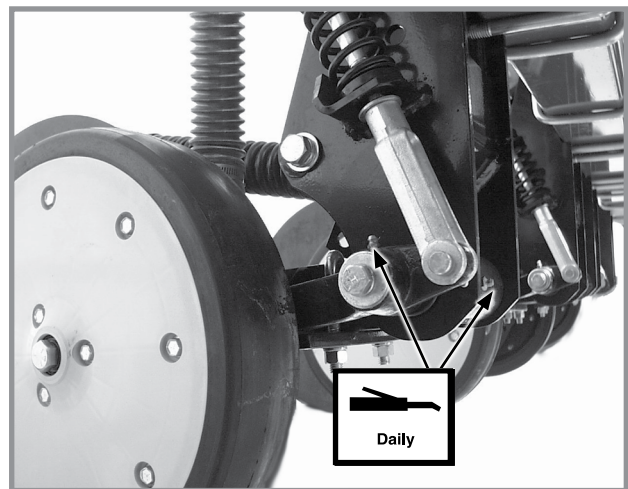

HD Single Disc Fertilizer Opener - 2
(Located On Wheel Arm And Opener Mount)

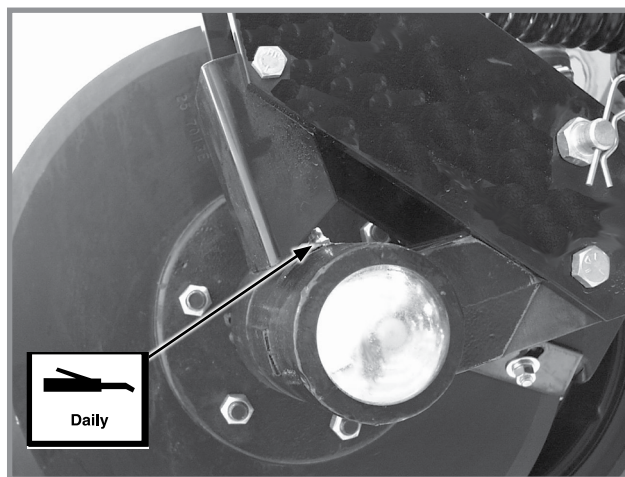

HD Single Disc Fertilizer Opener - 1
(Located On Disc Opener Spindle Hub)

ROW UNIT

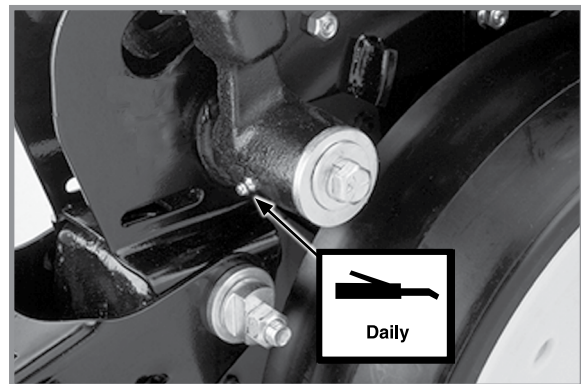

Gauge wheel arms - 1 per arm
(Seals in gauge wheel arm are installed with lip facing out to allow grease to purge dirt away from seal. Pump grease into arm until fresh grease appears between washers and arm.)

LIQUID FERTILIZER

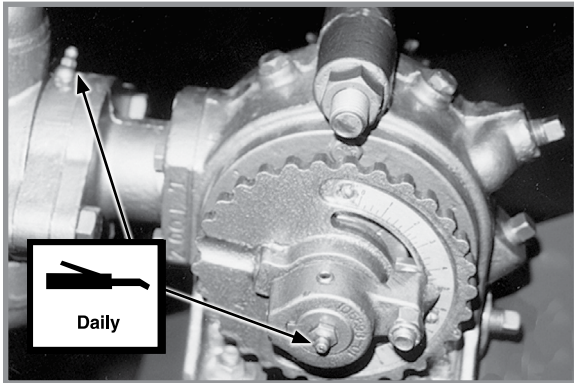

Liquid fertilizer piston pump - 2
(Fill fitting on outboard stuffing box until lubricant seeps out of drain hole in bottom.)

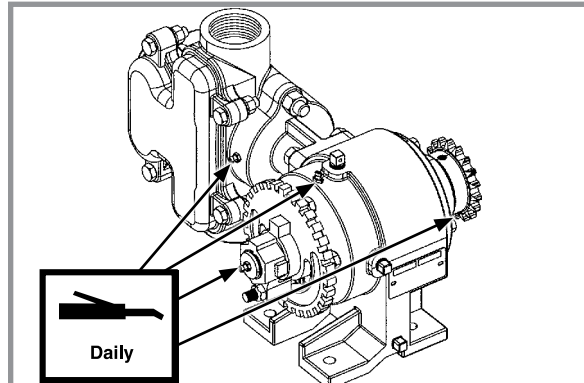

Liquid fertilizer piston pump - 4
(Fill fitting on outboard stuffing box until lubricant seeps out of drain hole in bottom.)

LIQUID FERTILIZER PISTON PUMP CRANK-CASE OIL LEVEL

Check crankcase oil daily and maintain at plug level. Fill as needed with EP 90 weight gear oil. Total oil capacity is approximately ¾ pint (0.35 L).

Refer to operator and instruction manual supplied with pump and flow divider for additional information.

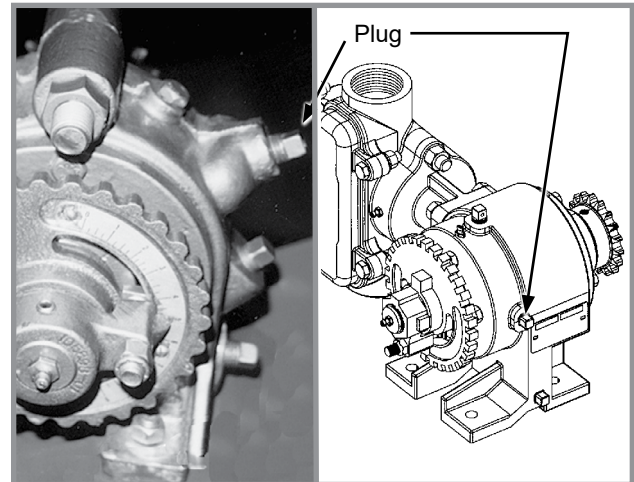

FERTILIZER CHECK VALVE CLEANING AND REPAIR

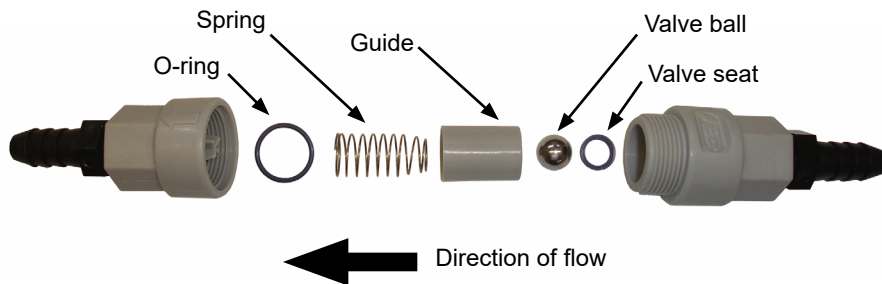

1. Unscrew valve body and separate halves. Note direction and location of parts.
2. Clean and inspect parts. Flush with clean water. Replace damaged parts.
3. Reassemble exactly as shown. O-ring and valve seat must be firmly in place inside each half of valve body.

PTO PUMP SHAFT AND TRACTOR PTO SHAFT

Lubricate the PTO Pump Shaft and the Tractor PTO Shaft with the LM 47 Long-Life Grease provided with the PTO Pump Mount Assembly kit once a week. The frequency of lubrication is based on normal operating conditions. Severe or unusual conditions may require more frequent attention.

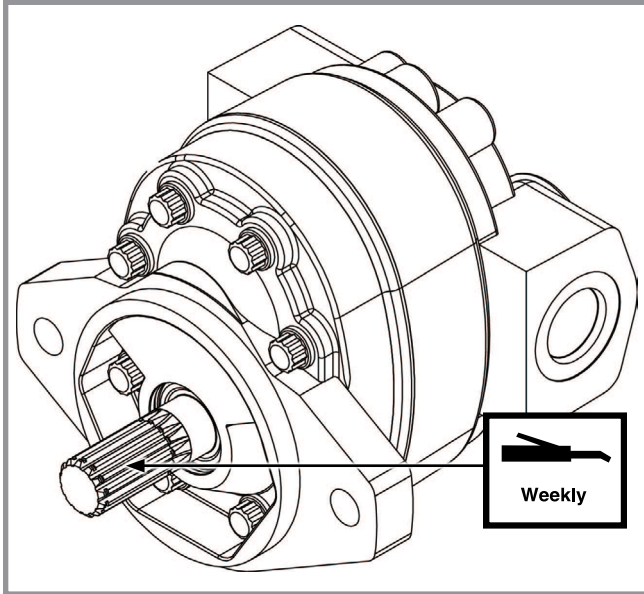

PTO Pump

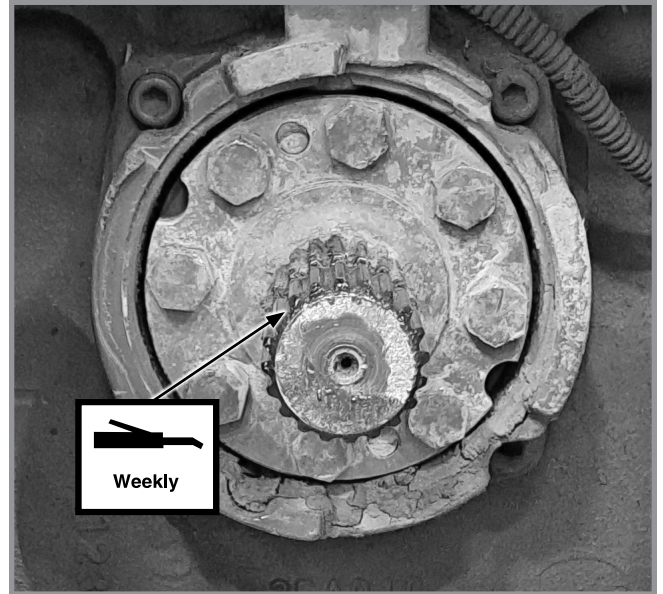

Tractor PTO Shaft

Lubricate the chain installed on the sprockets with a spray lube for chains once a day.

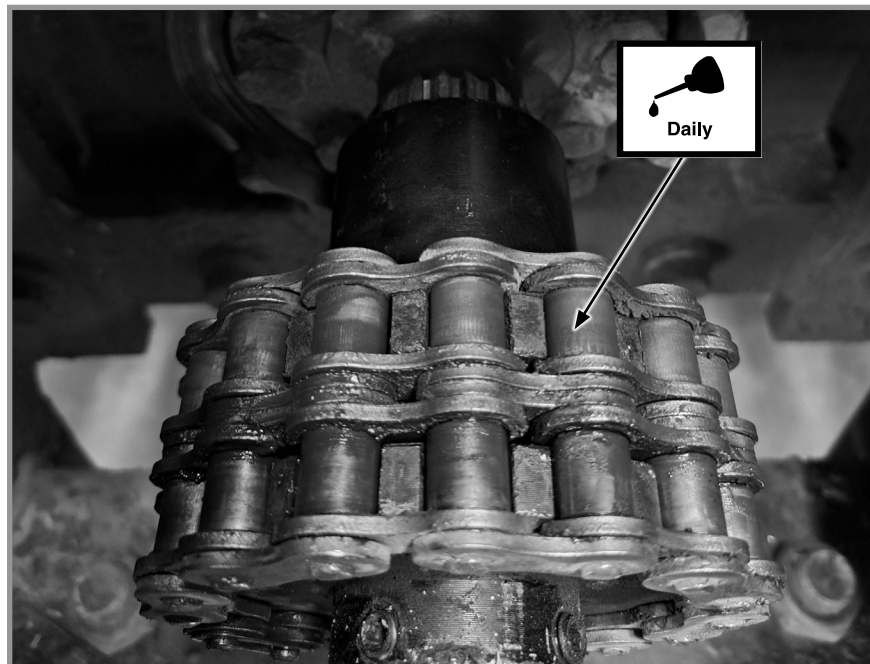

Chain

This page left blank intentionally.

MOUNTING BOLTS AND HARDWARE

Before operating planter for the first time, check all hardware is tight. Check all hardware again after first 50 hours of operation and beginning of each planting season.

All hardware used on the Kinze planter is Grade 5 (high strength) unless otherwise noted. Grade 5 cap screws are marked with three radial lines on the head. Hardware must be replaced with equal size, strength, and thread type.



WARNING



Loose transport wheel lug bolts can result in wheel separation from planter and result in death, serious injury, and damage to property and equipment. Check transport wheel lug nut torque before operating planter for the first time and periodically thereafter.



NOTICE

Over-tightening hardware can reduce its shock load capacity and cause equipment failure.

TORQUE VALUES CHART - PLATED HARDWARE

Diameter	Grade 2 (No marks) 		Grade 5 (3 marks) 		Grade 8 (6 marks) 	
	Coarse	Fine	Coarse	Fine	Coarse	Fine
1/4"	5.6 Nm	6.3 Nm	8.6 Nm	9.8 Nm	12 Nm	14 Nm
5/16"	11 Nm	12 Nm	18 Nm	19 Nm	24 Nm	27 Nm
3/8"	20 Nm	23 Nm	31 Nm	35 Nm	45 Nm	50 Nm
7/16"	34 Nm	37 Nm	50 Nm	56 Nm	71 Nm	79 Nm
1/2"	48 Nm	54 Nm	77 Nm	87 Nm	108 Nm	122 Nm
9/16"	68 Nm	81 Nm	108 Nm	122 Nm	156 Nm	176 Nm
5/8"	95 Nm	108 Nm	149 Nm	169 Nm	217 Nm	244 Nm
3/4"	176 Nm	197 Nm	271 Nm	298 Nm	380 Nm	427 Nm
7/8"	169 Nm	190 Nm	434 Nm	475 Nm	610 Nm	678 Nm
1"	258 Nm	278 Nm	651 Nm	719 Nm	915 Nm	1017 Nm
1 1/8"	359 Nm	407 Nm	814 Nm	908 Nm	1302 Nm	1458 Nm
1 1/4"	508 Nm	563 Nm	1139 Nm	1261 Nm	1844 Nm	2034 Nm
1 3/8"	664 Nm	759 Nm	1491 Nm	1695 Nm	2413 Nm	2752 Nm
1 1/2"	881 Nm	990 Nm	1966 Nm	2237 Nm	3128 Nm	3620 Nm

NOTE: Torque unplated hardware and bolts with lock nuts approximately 1/3 higher than above values. Torque bolts lubricated prior to installation to 70% of value shown in chart.

CYLINDER ROD PISTON RETAINING NUT TORQUE CHART

	Non-Nylock Nut	Nylock Nut
1/2"-20	55-70 ft-lb (75-95 N-m)	45-55 ft-lb (61-75 N-m)
3/4"-16	115-125 ft-lb (156-169 N-m)	100-115 ft-lb (136-156 N-m)
7/8"-14	150-180 ft-lb (203-244 N-m)	130-150 ft-lb (176-203 N-m)
1"-14	275-330 ft-lb (373-447 N-m)	250-275 ft-lb (339-373 ft-lb)
1 1/8"-12	300-375 ft-lb (407-508 N-m)	275-300 ft-lb (373-407 N-m)
1 1/4"-12	300-375 ft-lb (407-508 N-m)	275-300 ft-lb (373-407 N-m)

SPECIAL TORQUE VALUES & INSTRUCTIONS

Row unit parallel linkage bushing hardware	130 ft-lb (~176 Nm)
5/8" No till coulter spindle hardware	120 ft-lb (~162 Nm)
Transport Tire Inner Budd Nuts	315 ft-lb (~427 Nm)
Transport Tire Outer Budd Nuts	1075 ft-lb (~1458 Nm)
Row Unit Disc Opener Blade Bolt**	110 ft-lb (~149 Nm) **Left hand side is left hand thread.

TORQUE VALUES - WHEEL LUG NUTS

Wheel Nut Size	Torque Value	Interval
5/8" - 18 Wheel Lug Nuts and Lug Bolts	200 ft-lb (270 Nm)	<ul style="list-style-type: none"> Once before first planting; Again after first 50 km or 10 operational hours; Periodically thereafter (at least once before every planting season).
9/16" - 18 Wheel Lug Nuts and Lug Bolts	125 ft-lb (170 Nm)	<ul style="list-style-type: none"> Once before first planting; Again after first 50 km or 10 operational hours; Periodically thereafter (at least once before every planting season).

TIRE PRESSURE

WARNING

Explosive separation of rim and tire parts can cause death or serious injury. Overinflation, rim and tire servicing, improper use of rims and tires, or worn or improperly maintained tires could result in a tire explosion.

To prevent tire explosion:

- **Maintain proper tire pressure. Inflating a tire above or below the recommended pressure can cause tire damage.**
- **Mount tires only by properly trained personnel using proper equipment.**
- **Replace any tire with cuts or bubbles. Replace any damaged rims. Replace missing lug bolts and nuts.**
- **Do not weld or heat wheel assembly. Heating increases tire pressure.**

Model 3205 Operating Tire Pressure

Transport/ground drive - 7.50" x 20" Inflate to 2.8 bar (40 psi)

Contact drive - 4.10" x 6" Inflate to 3.5 bar (50 psi)



CHAIN TENSION ADJUSTMENT

Drive chains are equipped with spring loaded idlers and are self-adjusting. The only adjustment is to shorten chains if wear stretches a chain and reduces spring tension. Check idler pivot points periodically to ensure they rotate freely. See "Wrap Spring Wrench Assembly" (on applicable idler assemblies) in this section for additional information.

Additional chain links are in storage area inside wheel module.

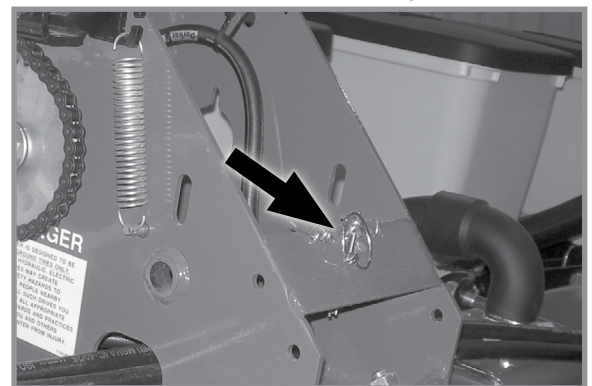

Chain link storage

FINGER PICKUP SEED METER INSPECTION/ADJUSTMENT

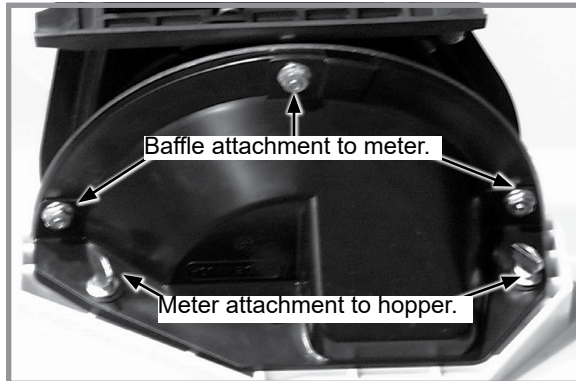

Removing meter and baffle

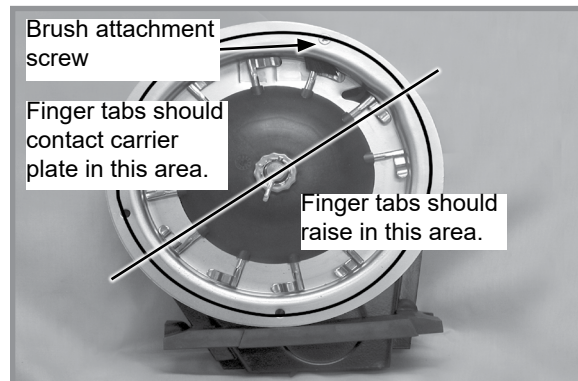

Proper finger operation

1. Remove two thumbscrews and meter from seed hopper and remove three cap screws and baffle from meter assembly.
2. Rotate seed meter drive by hand to ensure springs are holding tabs of fingers against carrier plat and fingers raise in correct area as shown in above photo.

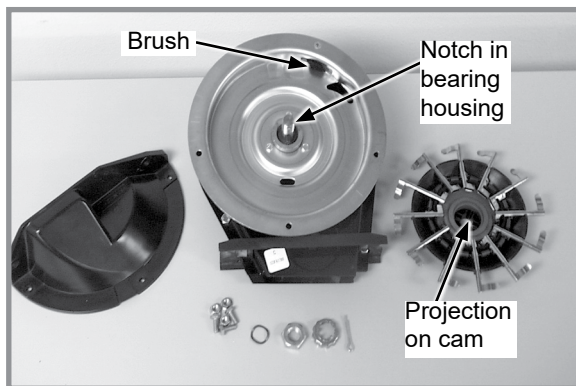

Finger pickup meter parts

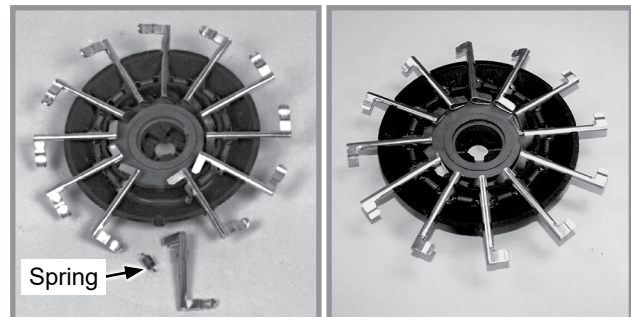

Corn Finger Assembly
(Position Spring Opening Toward Holder)

Oil Sunflower Finger Assembly

Buildup of debris or chaff may prevent proper finger operation and requires disassembly and cleaning of finger pickup meter.

1. Remove cotter pin, cover nut and adjusting nut and wave washer (If applicable) from drive shaft.
2. Carefully lift finger holder with fingers and cam off shaft and clean.
3. Check brush for wear and replace if necessary or after every 40 hectares per row of operation (Approximately 320 hectares of corn or sunflowers on a 8 row machine or 490 hectares on an 12 row machine).

NOTE: It is not necessary to remove finger holder to replace brush.

4. Remove springs from fingers and remove finger from holder by lifting it out of friction fit slot. Life expectancy of these parts is about 240-360 hectares per row of operation under average conditions.
5. Reassemble meter in reverse order after cleaning and replacing defective parts. Make sure open end of spring loop is toward inside of finger holder when replacing fingers.
6. Install fingers in holder so holder is flush with carrier plate when assembled. A cam projection aligns with a mating notch in bearing housing to ensure proper operation when assembled.

7. Check indentations on carrier plate for wear before installing finger holder on carrier plate. Excessive wear of carrier plate at indentations will cause over planting especially with small sizes of seed. Inspect carrier plate annually. Life expectancy should be 100-125 hectares per row of operation under average conditions.
8. Install wave washer and adjusting nut with finger holder flush against carrier. Tighten adjusting nut to fully compress wave washer. Back off nut $\frac{1}{2}$ to 2 flats to obtain rolling torque of 2.5 Nm to 2.8 Nm.
9. Turn finger holder by hand to make sure it is firmly against carrier plate, but can be rotated with moderate force.
10. Install cover nut and cotter pin. Reinstall baffle.

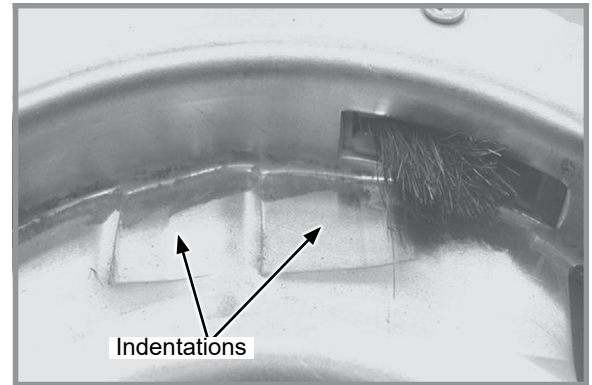

Worn carrier plate

NOTE: Check adjusting nut tightness on each unit after first day of use and periodically thereafter (at least once before every planting season).

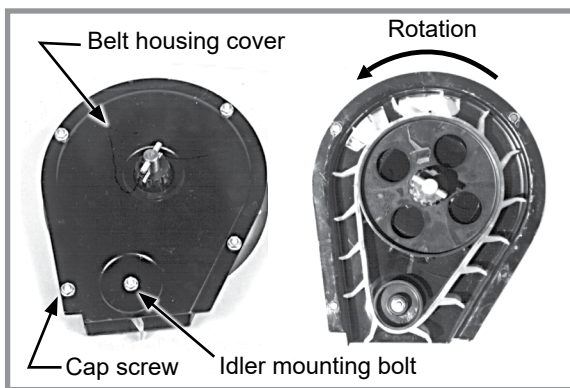

Belt idler

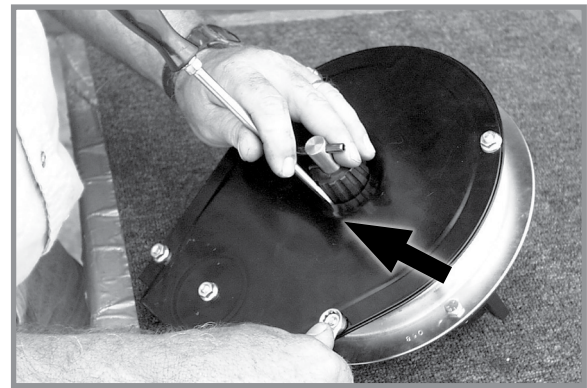

Centering belt housing cover

Remove four cap screws around edge of housing cover and nut from belt idler mounting bolt. Paddles must be correctly oriented as shown above. If belt is replaced. A diagram molded into drive sprocket shows correct orientation.

NOTICE

Do not overtighten hardware or components may be damaged.

Reinstall housing cover. **DO NOT TIGHTEN** hardware. Wedge a screwdriver between sprocket hub and housing cover as shown above. Pry cover down until centered on belt housing and tighten hardware. Rotate meter drive shaft and check idler alignment. Seed belt should "run" centered on idler or with only slight contact with belt housing or cover.

CLEANING FINGER PICKUP SEED METER FOR STORAGE

1. Disassemble meter and blow out any foreign material.
2. Wash **ONLY** in mild soap and water. Do not use gasoline, kerosene, or any other petroleum based product. Dry thoroughly.
3. Coat lightly with a rust inhibitor.
4. Rotate finger assembly so finger does not touch brush.
5. Reassemble and store in a dry, rodent-free location.

BRUSH-TYPE SEED METER MAINTENANCE

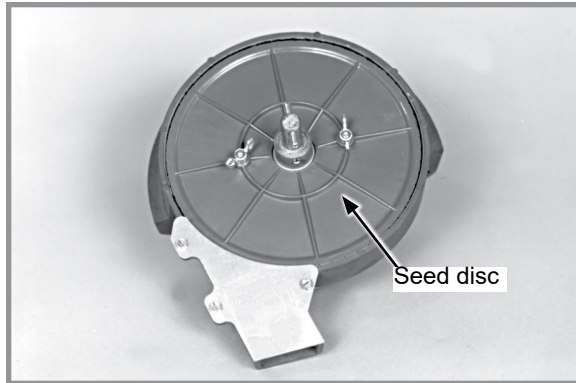

Brush-type seed meter seed disc installed

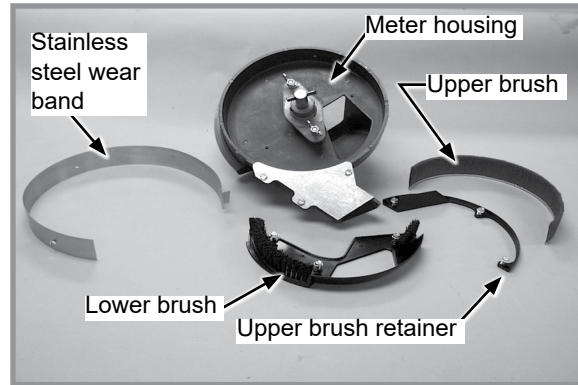

Brush-type seed meter parts

Use clean, high quality seed. Damaged or cracked seed, hulls, or foreign materials can become lodged in upper brush and greatly reduce meter accuracy. Remove seed disc daily and check for buildup of foreign material on seed disc, particularly in seed loading slots. Clean disc by washing it with soap and water. Check for cracked seed, hulls, etc. lodged between brush retainer and stainless steel wear band which can greatly reduce accuracy of the meter because upper brush will not be able to retain seed in seed disc pocket. Thoroughly clean brush areas of meter housing.

SEED DISC WEAR

Most seed disc wear is found in the agitation groove area (area between seed loading slots). Wear affects planting accuracy at high RPM. Lay a straight edge across disc surface at agitation groove area and measure gap between disc and straight edge. If agitation groove areas are worn in excess of 7.6 mm and accuracy starts to drop off at higher meter RPM, replace seed disc. Estimated seed disc life expectancy under normal operating conditions is approximately 80 hectares per row. Severe operating conditions such as dust, lack of lubrication or abrasive seed coating could reduce seed disc life expectancy to under 40 hectares per row.

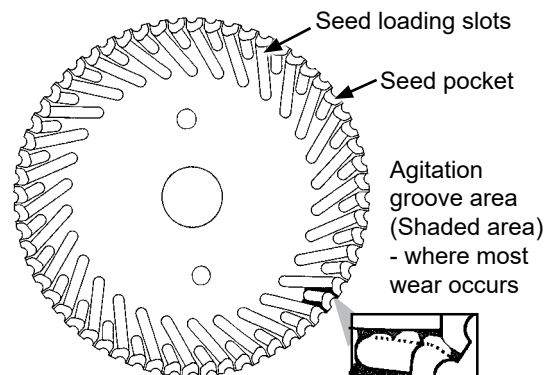

STAINLESS STEEL WEAR BAND

NOTICE	If wear band wears through or if meter is used without wear band in place, meter housing may be damaged.
---------------	---

Stainless steel wear band protects meter housing from wear and is .76 mm thick. Replace wear band when there is approximately .5 mm of wear in primary wear area. Estimated life expectancy of stainless steel wear band is 100-325 hectares per row.

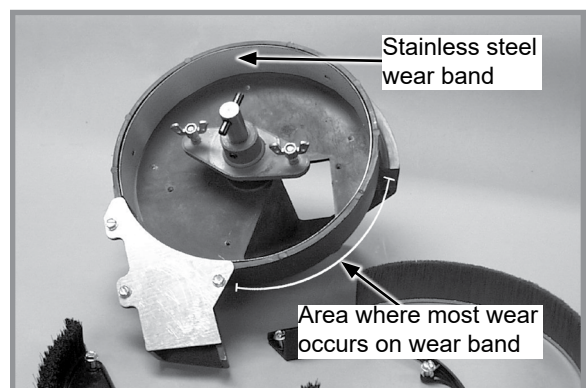

Stainless steel wear band

UPPER BRUSH

Upper brush holds seed in seed disc pocket in seed retention area. Brush must apply enough pressure against seed in seed disc pocket as disc rotates through seed retention area to prevent seed from dropping out of disc pocket. A damaged spot, excessive brush wear, or foreign material lodged in brush may greatly reduce meter performance.

Replace upper brush at 50-160 hectares per row of use or sooner if damage or excessive wear is found. Position upper brush into inner perimeter of seed retention area. Make sure base of brush is tight against bottom of meter housing. Install brush retainer and three hex head screws. Tighten screws in sequence shown in photo at right.

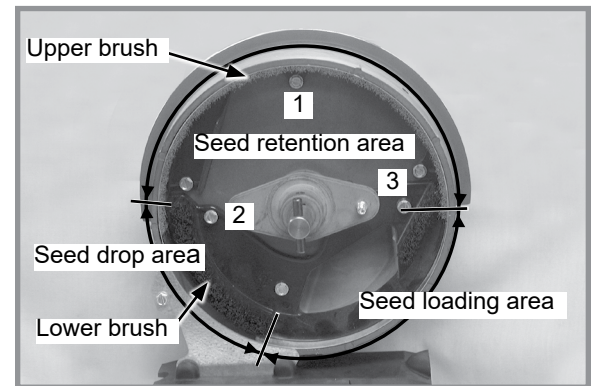

Upper brush installation

NOTE: Use GD11122 upper brush retainer for soybean and cotton discs. Use GD8237 upper brush retainer for milo/grain sorghum discs.

LOWER BRUSH

Lower brush moves seed down seed loading slots to seed pockets, isolates seed in reservoir from entering seed tube, and cleans seed loading slots. Estimated lower brush life expectancy is 100-325 hectares per row. Replace lower brush if bristles are deformed or missing, or if there are cracks in brush retainer.

CLEANING BRUSH-TYPE SEED METER FOR STORAGE

1. Remove meter from seed hopper by removing two thumbscrews securing meter to hopper.
2. Remove seed disc and wash with soap and water and dry thoroughly.
3. Remove three hex head screws from brush retainer. Remove brush retainer and upper brush.
4. Remove three hex head screws from lower brush. Remove lower brush and stainless steel wear band.
5. Wash all parts and meter housing with soap and water and dry thoroughly.
6. Inspect all parts and replace worn parts.
7. Reassemble meter except for seed disc. Store meter in a dry, rodent-free space with seed disc removed.

VACUUM SEED METER MAINTENANCE

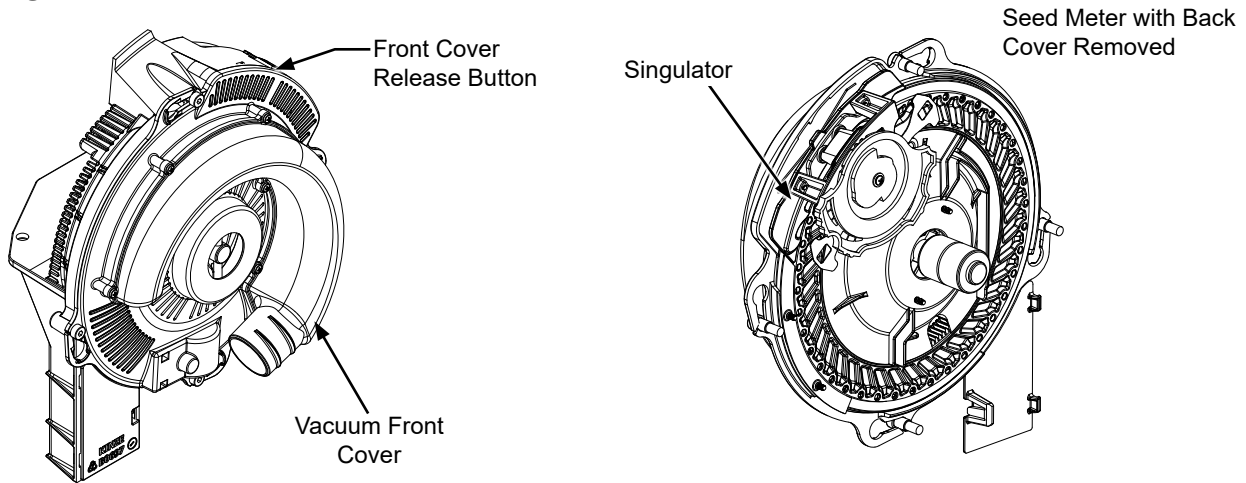

Before each planting season inspect seed discs and singulator and clean or replace as needed.

Use clean, high quality seed for maximum meter accuracy. Damaged or cracked seed, hulls, and foreign material may become lodged in seed disc orifices and greatly reduce meter accuracy.

Inspect and clean seed discs daily checking for any buildup of foreign material and blocked orifices. If seed disc orifices are plugged frequently with seed remnants, remnants ejector wheel may need to be replaced. Clean seed disc by washing it with soap and water. Dry thoroughly.

Inspect singulator blades and guide for wear after every 200 acres (81 hectares) per row of operation. If adjustment of singulator blade does not affect meter performance or if blades appear worn, singulator blade may need to be replaced.

Replace seed disc or vacuum seal if abnormally high vacuum is required or if consistent operation cannot be achieved.

See [“Preparing Planter for Storage”](#) located in operator’s manual for additional Vacuum Seed Metering System maintenance.

NOTE: Remove seed discs from meters for annual storage and store them vertically on a dowel or pipe.

SEED METER CLEANOUT

NOTE: Use of damaged seed or seed containing foreign material will cause plugging of seed cell orifices and require more frequent seed meter cleanout to prevent underplanting.

Thorough seed meter cleanout is important to maintain genetic purity.

1. Disengage seed drive and remove seed hopper and meter.
2. Dump seed from right rear corner of hopper into a container.
3. Lay hopper on its right side. Push release button and rotate seed meter vacuum cover clockwise to align keyhole slots with bolt heads. Lift off cover.
4. Rotate seed disc hub clockwise to unlock and remove seed disc.
5. Empty meter.
6. Thoroughly inspect meter to ensure all seed is removed.
7. Replace seed disc. Install vacuum cover.

This page left blank intentionally.

DRAG CLOSING ATTACHMENT

Inspect each drag closing attachment and replace any worn or broken parts before storing planter. Check for loose hardware and tighten as needed.

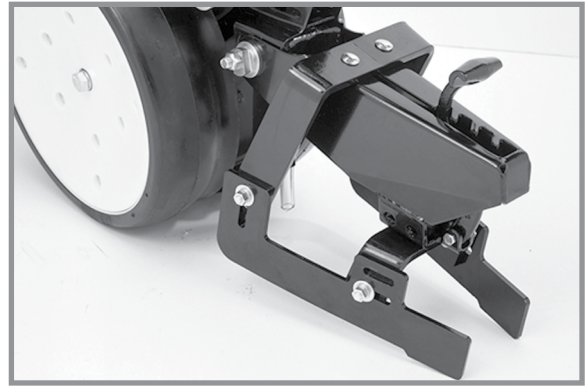

Drag Closing Attachment

GAUGE WHEEL ADJUSTMENT

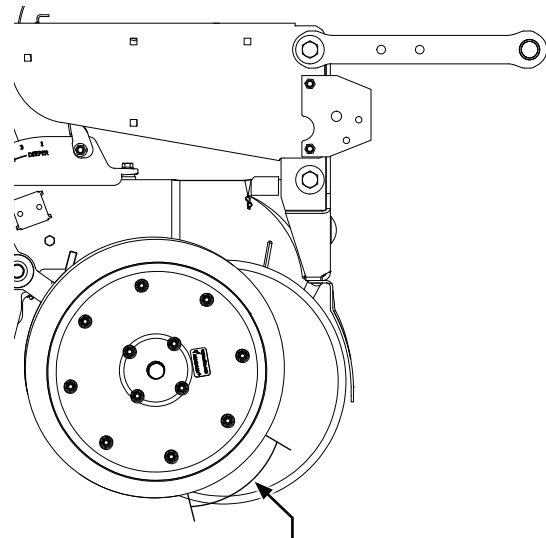
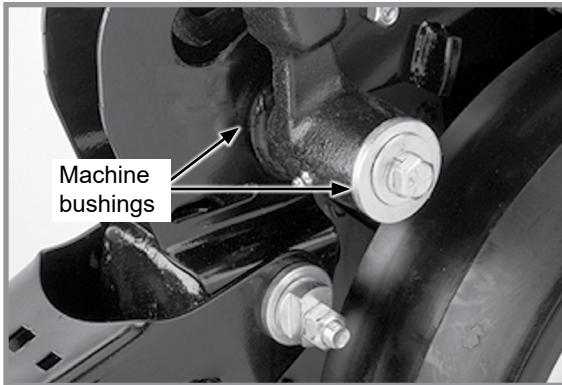

Shim gauge wheel to lightly contact opener disc blade in this area for 4" to 6" (10-15 cm). Check adjustment in operating position.

Gauge Wheel Adjustment

Gauge wheels should lightly contact opener blades to prevent accumulation of dirt or trash. Gauge wheels and opener blades should turn with only slight resistance.

Add or remove machine bushings between shank and gauge wheel arm to adjust clearance between gauge wheels and opener blades. Store remaining machine bushings between gauge wheel arm and flat washer on outer side of gauge wheel arm.

NOTE: It may be desirable to space gauge wheel further from blade when operating in sticky soils.

GAUGE WHEEL ARM BUSHING/SEAL REPLACEMENT

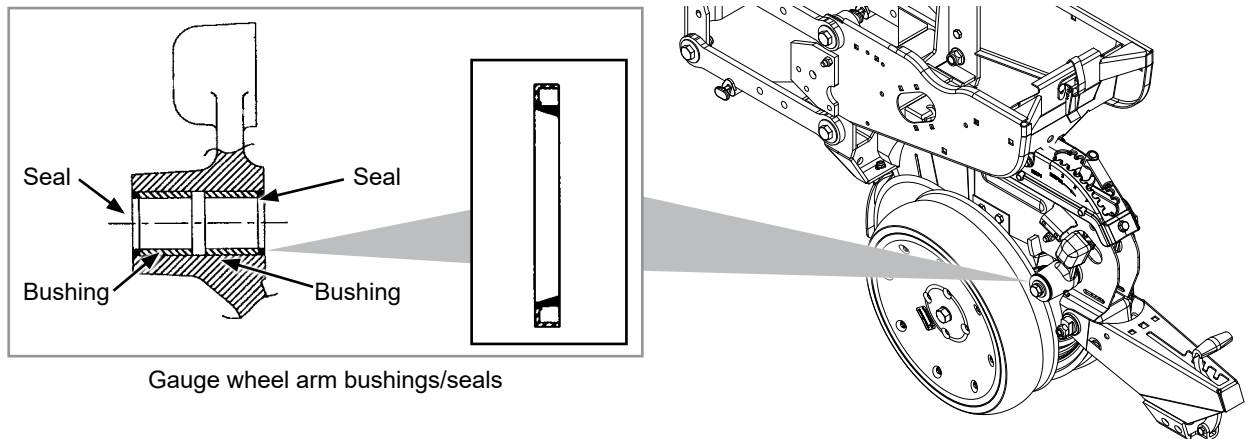

Gauge wheel arm bushings/seals

NOTE: Gauge Wheel Arm Bushing and Seal Driver Kit (G1K296) is available through your Kinze Dealer.

1. Remove gauge wheel from arm.
2. Remove gauge wheel arm from shank assembly.
3. Remove seal and bushing and discard. Clean and dry inner bore.
4. Drive/press replacement bushing inside bore of arm to a depth of .125" (~31 mm) below flush.
5. Coat wiping edge of seal with grease.
6. Drive/press seal into place with lip to outside.

NOTE: Use extra care to protect the sealing lip during installation. Apply uniform pressure to assemble the seal into the bore of the arm. Never apply a direct hammer blow to the seal surface.

7. Inspect gauge wheel pivot spindle.
8. Reinstall gauge wheel arm assembly and gauge wheel.

NOTE: Use special machine bushing between gauge wheel arm and gauge wheel.

9. Shim for proper gauge wheel tire/disc blade clearance.
10. Lubricate with an SAE multipurpose grease.

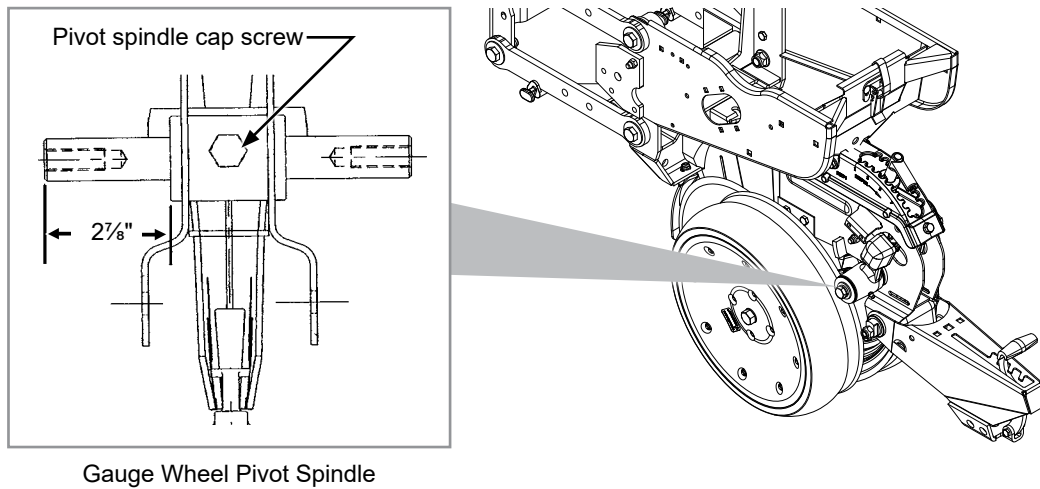
GAUGE WHEEL ARM PIVOT SPINDLE REPLACEMENT

1. Remove gauge wheel and arm assemblies from shank assembly.
2. Remove $\frac{1}{2}$ " x $\frac{3}{4}$ " cap screw that locks pivot spindle in place and remove spindle.
3. Install replacement spindle and position as shown. Exact centering is critical.
4. Install $\frac{1}{2}$ " x $\frac{3}{4}$ " cap screw and torque to lock pivot spindle in place.
5. Install gauge wheel and arm assemblies. Shim for proper gauge wheel tire/disc blade clearance.

15" SEED OPENER DISC BLADE/BEARING ASSEMBLY

NOTICE

Excessive blade contact may result in premature disc opener bearing/hub failures and excessive wear on seed tube guard/inner scraper. When properly adjusted, if one blade is held in fixed position, opposite blade should rotate with less than 5 pounds (~22 N) force at outer edge of blade.

Maintain approximately $1" \pm \frac{1}{2}"$ (~2.5 ± 1 cm) of blade-to-blade contact to properly open and form seed trench. As blade diameter decreases due to wear, it is necessary to relocate machine bushings from inside to outside to maintain $1" \pm \frac{1}{2}"$ (~2.5 ± 1 cm) of contact.

NOTE: Proper blade clearance is critical. Blades should have $1" \pm \frac{1}{2}"$ (~2.5 ± 1 cm) contact in this area. When blades are turned by hand in opposite directions against each other, there should be only light resistance to turning. Re-adjust blade scraper if necessary to center it between the blades.

NOTE: Replace blades if proper blade-to-blade contact cannot be maintained after relocating machine bushings or if blade diameter wears below $14\frac{1}{2}"$ (~37 cm).

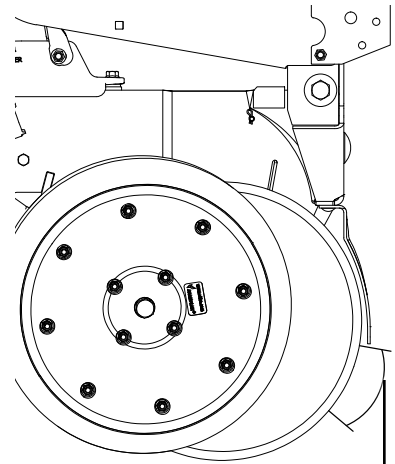

Approximately $1" \pm \frac{1}{2}"$
(~2.5 ± 1 cm) of
blade-to-blade contact.

Continue on the next page.

REPLACE DISC BLADE/BEARING ASSEMBLY

NOTE: Only bearing may need to be replaced if there is excessive endplay or if bearing sounds or feels rough when disc blade is rotated.

1. Remove gauge wheel, scraper, and bearing dust cap.
2. Remove cap screw, washer and disc blade/bearing assembly. Machine bushings between shank and disc blade are used to maintain approximate $1" \pm \frac{1}{2}"$ ($\sim 2,5 \pm 1$ cm) of blade-to-blade contact.

NOTICE

Left hand side of opener uses a left hand threaded cap screw. DO NOT OVER TIGHTEN. Damage to shank threads require replacement of row unit shank assembly.

3. Install machine bushing(s), new disc blade bearing assembly, washer and cap screw. Torque $\frac{5}{8}"$ -11 Grade 5 cap screw to 110 ft-lb (~ 149 Nm).

NOTE: Replace disc blades only with disc blades of equal thickness.

4. Install bearing dust cap, scraper, and gauge wheel.

REPLACE BEARING ONLY

1. Remove gauge wheel, scraper, bearing cap, cap screw, washer and disc blade/bearing assembly.
2. Remove $\frac{1}{4}"$ rivets from bearing housing to expose bearing.
3. Installing new bearing. install three evenly spaced $\frac{1}{4}"$ cap screws into three of six holes in bearing housing to hold bearing and bearing housing in place. Install rivets in other three holes. Remove $\frac{1}{4}"$ cap screws and install rivets in those three holes.
4. Reinstall disc blade/bearing assembly, washer and cap screw. Torque $\frac{5}{8}"$ -11 cap screw to 110 ft-lb (~ 149 Nm).
5. Install bearing dust cap, scraper, and gauge wheel.

SEED TUBE GUARD/INNER SCRAPER

Seed tube guard protects seed tube and acts as inner scraper for seed opener disc blades.

Remove seed tube and check for wear. Excessive wear on seed tube indicates a worn seed tube guard. Replace seed tube guard if it measures 16 mm or less at lower end. A new seed tube guard measures approximately 22 mm.

NOTE: No till planting or planting in hard ground conditions, especially when planter is not equipped with no till coulters, and/or excessive blade-to-blade contact increases seed tube guard wear and requires more frequent inspection and/or replacement.

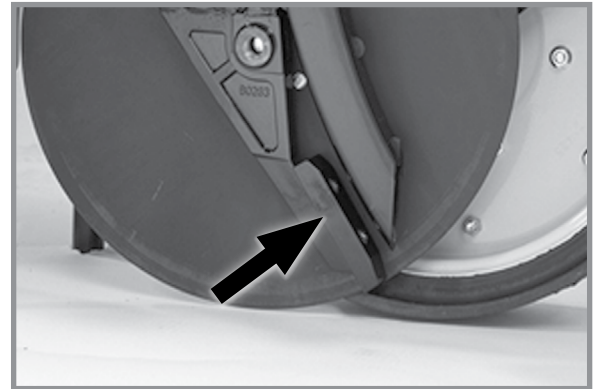

Seed tube guard/inner scraper
(Gauge wheel/seed opener disc blade removed)

NOTICE

Over tightening hex socket head cap screws may damage shank threads and require replacement of shank. An excessively worn seed tube guard may allow blades to wear into row unit shank, also requiring replacement of shank.

Remove seed tube and two hex socket head cap screws that attach seed tube guard. Hold replacement seed tube guard centered between seed opener disc blades. Install hex socket head cap screws. **DO NOT TIGHTEN.** Using a clamp or vise-grip, squeeze opener blades together in front of seed tube guard. Tighten seed tube guard retaining screws. Remove clamps. Distance between seed tube guard and opener blades should be equal on both sides. Reinstall seed tube.

GRANULAR CHEMICAL ATTACHMENT

Before storing planter, disengage granular chemical drive by rotating throwout knob $\frac{1}{4}$ turn counterclockwise. Remove drive chain and empty and clean all granular chemical hoppers. Clean drive chains and coat them with a rust preventive spray or submerge chains in oil. Inspect and replace worn or broken parts.

Install hoppers and chains. Check chain alignment.

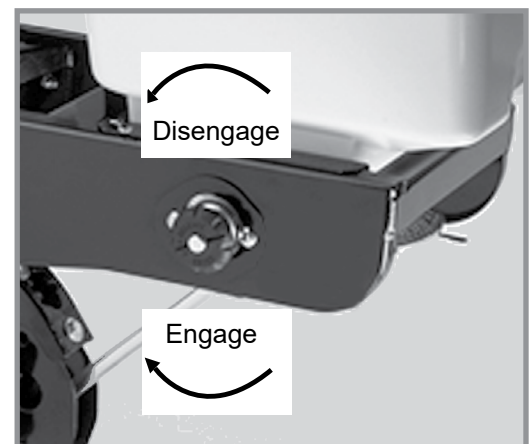

Granular chemical throwout knob

ROW UNIT MOUNTED RESIDUE WHEEL

Wheel hub is equipped with sealed bearings. If a bearing sounds or feels rough when wheel is rotated, replace them.

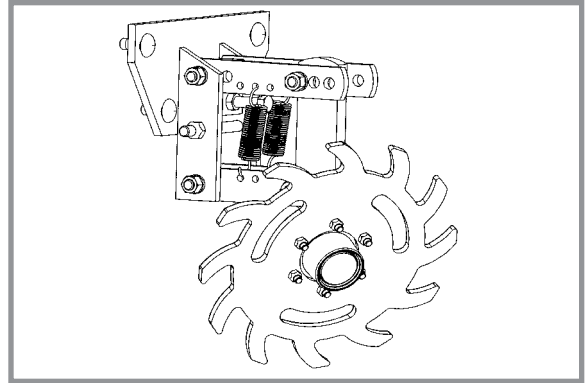

Row unit mounted residue wheels

ROW UNIT MOUNTED NO TILL COULTER

Check nuts and hardware periodically for proper torque. Be sure coulter is positioned square with row unit and aligned in front of row unit disc opener.

NOTE: Torque $\frac{5}{8}$ " spindle hardware to 120 ft-lb (~162 Nm).

Coulter blade can be adjusted to one of four settings. Initially blade is set in highest position. As blade wears it can be adjusted to one of three lower settings. See "Row Unit Mounted No Till Coulter" on page 3-19.

Replace 16" (~41 cm) diameter coulter blade when worn to 14½" (~37 cm).



Row unit mounted no till coulter

COULTER MOUNTED RESIDUE WHEELS

Wheel hubs are equipped with sealed bearings. If bearings sound or feel rough when wheel is rotated, replace them.



Coulter mounted residue wheels

ROW MARKER SEQUENCING/FLOW CONTROL VALVE INSPECTION

WARNING

Pressurized hydraulic fluid can penetrate body tissue and result in death, serious infection, or other injuries. Fluid injected under skin must be **IMMEDIATELY** removed by a surgeon familiar with this type of injury. Make sure connections are tight and hoses and fittings are not damaged before applying system pressure. Leaks can be invisible. Keep away from suspected leaks. Relieve pressure before searching for leaks or performing any system maintenance.

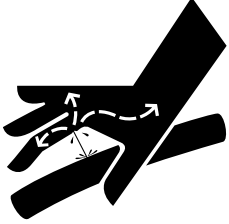

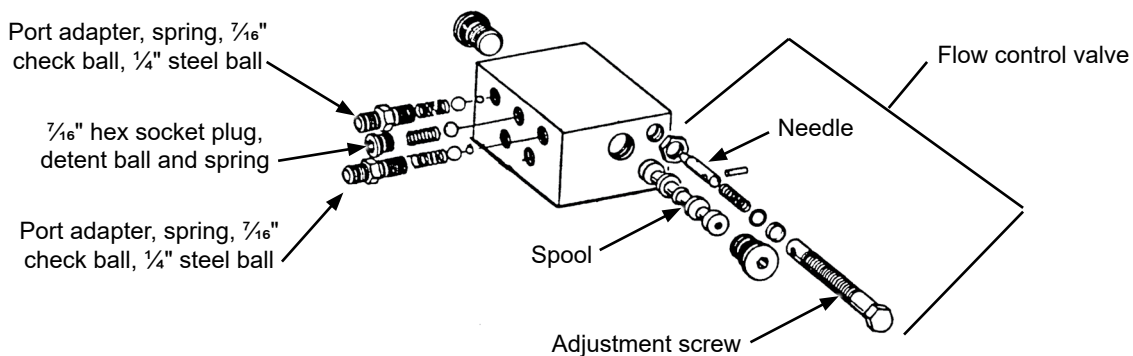

The valve block assembly consists of the row marker sequencing and flow control valves in one assembly. Sequencing valve portion consists of a chambered body containing a spool and series of check valves to direct hydraulic oil flow.

1. Remove valve block assembly from planter.
2. Remove detent assembly and port adapter assemblies from rear of valve block.

NOTICE

Damage to spool may occur if detent assembly and port adapter assemblies are not removed prior to removal of spool.

3. Remove plug from both sides of valve block and remove spool.
4. Inspect all parts for pitting, contamination, or foreign material. Check seating surfaces inside valve. Replace defective parts.
5. Lubricate spool with a light oil and reinstall. Check spool moves freely in valve body.

NOTE: Make sure correct check ball(s) and spring are installed in each valve bore upon reassembly.

A flow control valve is located on each side of block assembly. Adjust flow control valves for raise and lower speed as part of assembly procedure or upon initial operation. If valve fails to function properly or requires frequent adjustment, remove needle valve for inspection. Check for foreign material and contamination. Make sure needle moves freely in adjustment screw. Replace defective components.

NOTE: Hydraulics operate slowly when oil is cold. Make all adjustments with warm oil.

ROW MARKER BEARING LUBRICATION OR REPLACEMENT

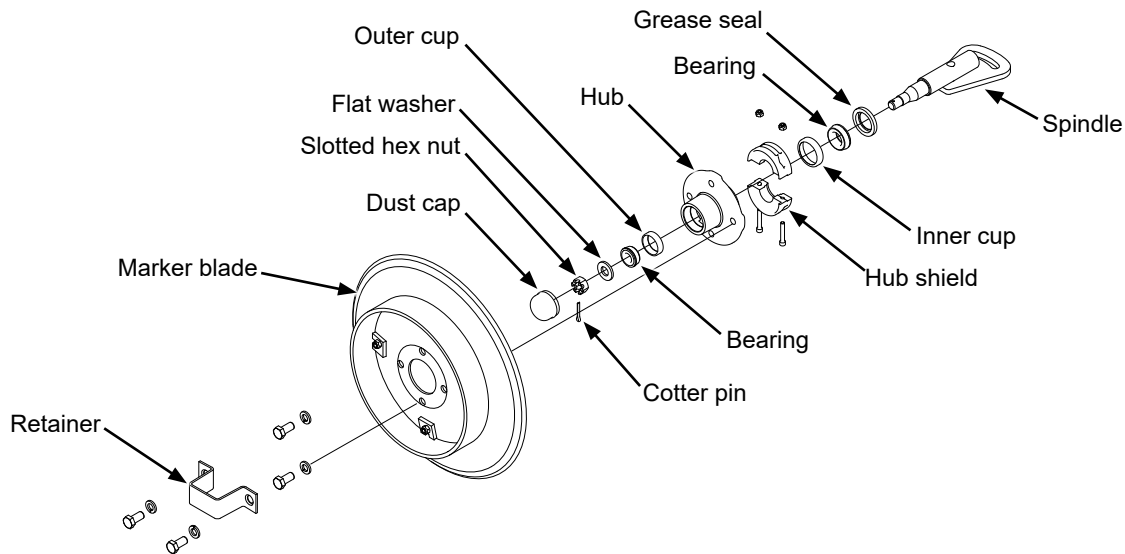

1. Remove retainer and marker blade.
2. Remove dust cap from hub.
2. Remove hub shield. Note direction of installation.
3. Remove cotter pin, slotted hex nut, and washer.
4. Slide hub from spindle.
5. Remove bearings and cups and discard if bearings are being replaced. Clean hub and dry. Remove bearings only and not cups if repacking.
6. Press in new bearing cups with thickest edge facing in. (Bearing replacement procedure only.)
7. Pack bearings with heavy duty wheel bearing grease thoroughly forcing grease between roller cone and bearing cage. Fill the space between the bearing cups in the hub with grease.
8. Install rubber seal into grease seal. Place inner bearing in place and press in new rubber seal/grease seal.
9. Clean spindle and install hub.
10. Install outer bearing, washer and slotted hex nut. Tighten slotted hex nut while rotating hub until there is some drag. This ensures all bearing surfaces are in contact. Back off slotted nut to nearest locking slot and install cotter pin.
11. Fill dust caps approximately $\frac{3}{4}$ full of wheel bearing grease and install on hub.
12. Install hub shield.
13. Install marker blade and retainer on hub. Tighten hardware evenly.

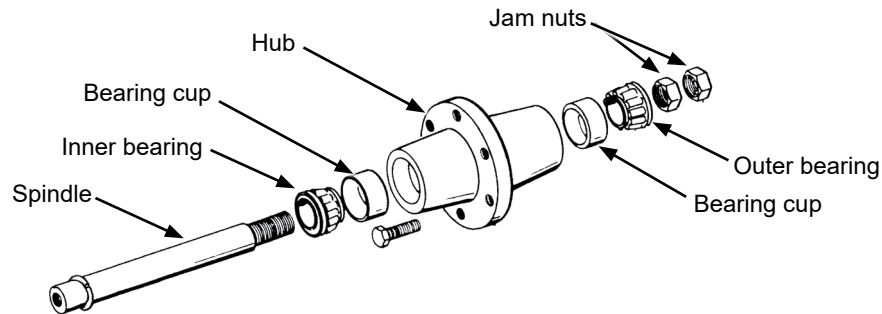
WHEEL BEARING REPACK OR REPLACEMENT

1. Raise tire clear of ground and remove wheel.
2. Remove double jam nuts and slide hub from spindle.
3. Remove bearings and cups and discard if bearings are being replaced. Clean hub and dry. Remove bearings only and not cups if repacking.
4. Press in new bearing cups with thickest edge facing in. (Bearing replacement procedure only.)
5. Pack bearings with heavy duty wheel bearing grease thoroughly forcing grease between roller cone and bearing cage. Fill space between bearing cups and hub with grease.
6. Place inner bearing in place.
7. Clean spindle and install hub.
8. Install outer bearing and jam nut. Tighten jam nut while rotating hub until there is some drag. This ensures all bearing surfaces are in contact. Back off jam nut $\frac{1}{4}$ turn or until there is only slight drag when rotating hub. Install second jam nut to lock against first.
9. Install wheel on hub. Tighten hardware evenly.

POINT ROW CLUTCH MAINTENANCE

Point row clutch is permanently lubricated and sealed and requires no periodic maintenance.

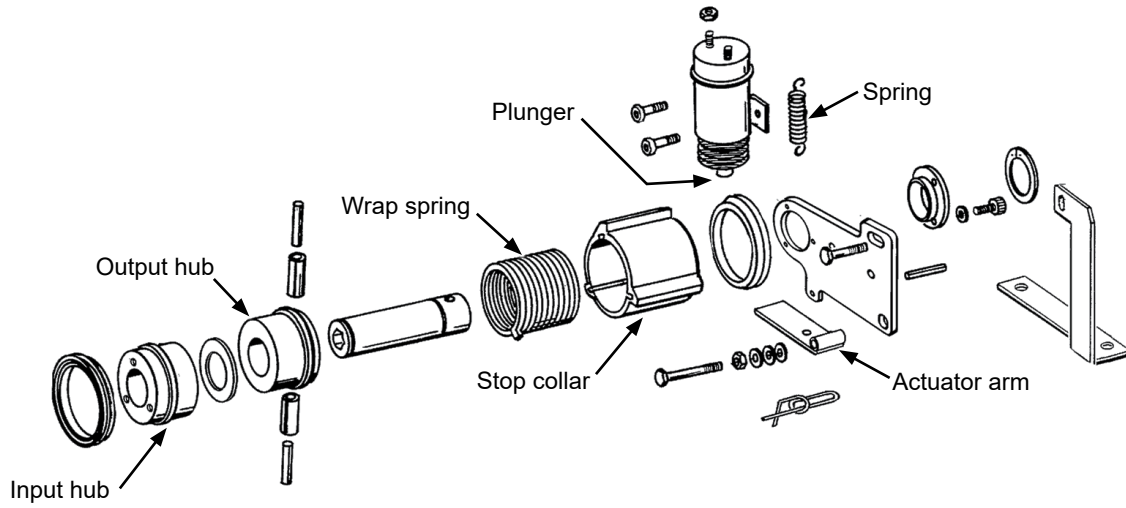

Single point row clutch main parts

TESTING

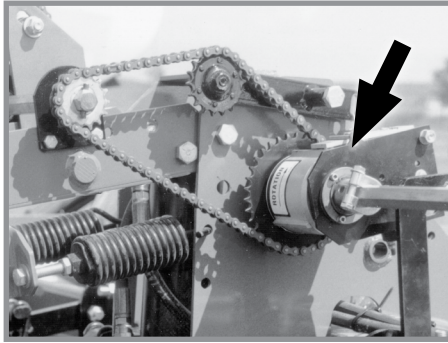

Point row clutch (single shown)

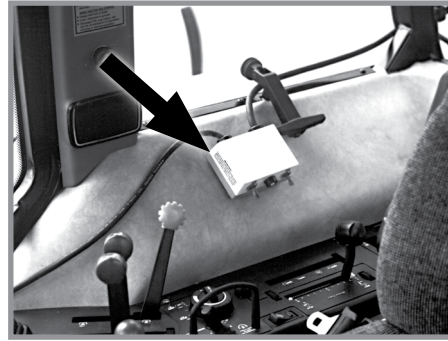

Point row clutch control box

Control box is equipped with a circuit breaker. Press red button on circuit breaker to reset. If circuit breaker continues to trip, see "Point Row Clutch Troubleshooting" in Troubleshooting section.

If control box circuit breaker is not tripped, determine if problem is electrical or mechanical.

Place operation switch in RIGHT or LEFT position. Solenoid plunger will retract causing a clicking sound if it is operating properly. Touch plunger with a metal object to check if it is electrically magnetized. Check clutch and wiring harness for power with a test light or volt meter.

NOTE: R.H. clutch operates clockwise and L.H. clutch operates counterclockwise. Clutch parts such as the wrap spring are side specific. Use correct repair part if a clutch must be repaired.

ACTUATOR ARM ADJUSTMENT

Gap between actuator arm and stop on stop collar should be $3.2 \text{ mm} \pm .8 \text{ mm}$ when solenoid is NOT engaged.

Loosen nut on mounting pin and move pin in slot until there is a $3.2 \text{ mm} \pm .8 \text{ mm}$ gap between arm and stop on stop collar. Retighten nut.

$3.2 \text{ mm} \pm .8 \text{ mm}$

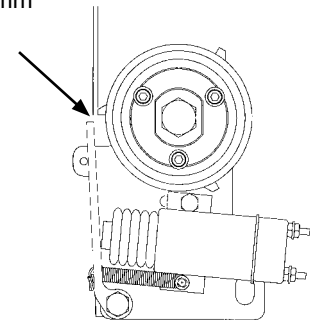

PISTON PUMP STORAGE

NOTICE

Entrance of air into pump will cause rapid and severe corrosion. **KEEP AIR OUT OF PUMP!**

NOTE: SUSPENSION FERTILIZER must be flushed from pump for ANY storage period.

1. Flush pump with 20 to 40 liters of fresh water and circulate until all corrosive salts are dissolved in pump.
2. Set pump on 10. Draw in a mixture of half diesel fuel and 10 weight oil until discharge is clean. Plug inlet and outlet.

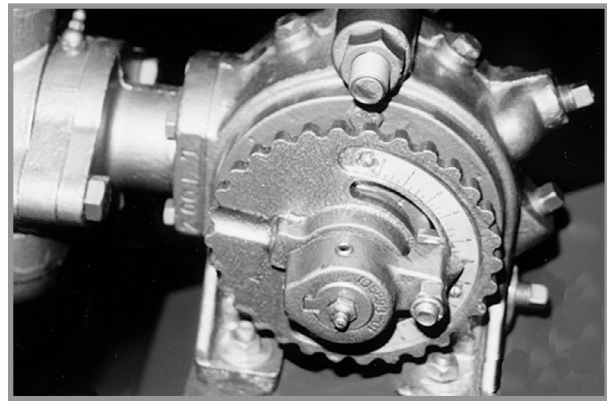
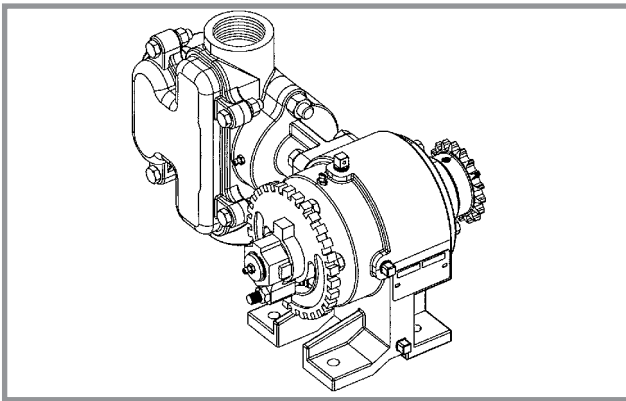

Liquid fertilizer piston pump

PREPARING PLANTER FOR STORAGE

- Store planter in a dry sheltered area if possible. Refer to “Safety Lockups” in Machine Operation section for proper safety lockup installation during storage.
- Remove all trash that may be wrapped on sprockets or shafts and remove dirt that can draw and hold moisture.
- Clean all drive chains and coat with a rust preventative spray, or remove chains and submerge in oil.
- Lubricate planter and row units at all lubrication points.
- Inspect planter for parts that are in need of replacement and order during “off” season.
- Make sure seed and granular chemical hoppers are empty and clean.
- Clean seed meters and store in a dry, rodent-free area.
- Remove seed discs from brush-type seed meters, clean and store meters with discs removed.
- Grease or paint disc openers/blades and row marker disc blades to prevent rust.
- Flush liquid fertilizer tanks, hoses and metering pump with clean water. See “Piston Pump Storage” if applicable.
- Empty and clean dry fertilizer hoppers. Disassemble and clean metering augers. Reassemble and coat all metal parts with rust preventative.

ELECTRICAL WIRING DIAGRAM FOR LIGHTING PACKAGE

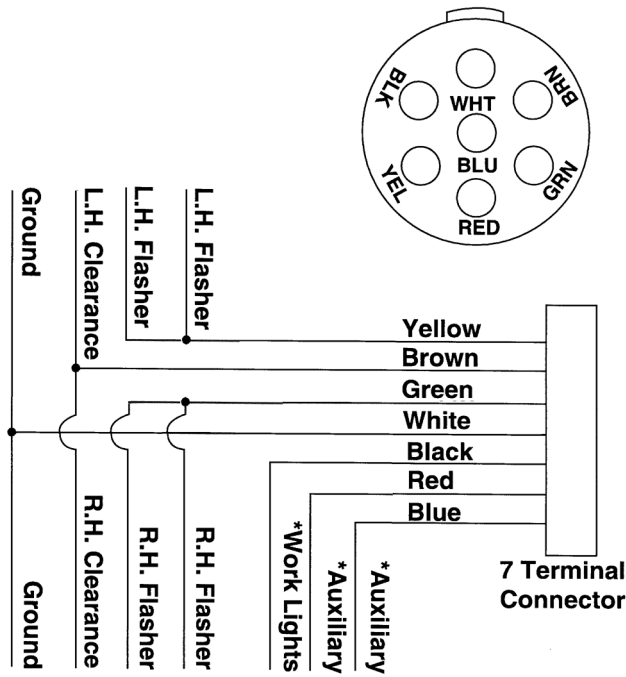

* Optional customer-supplied auxiliary lights and wires may be wired into existing plug terminals.

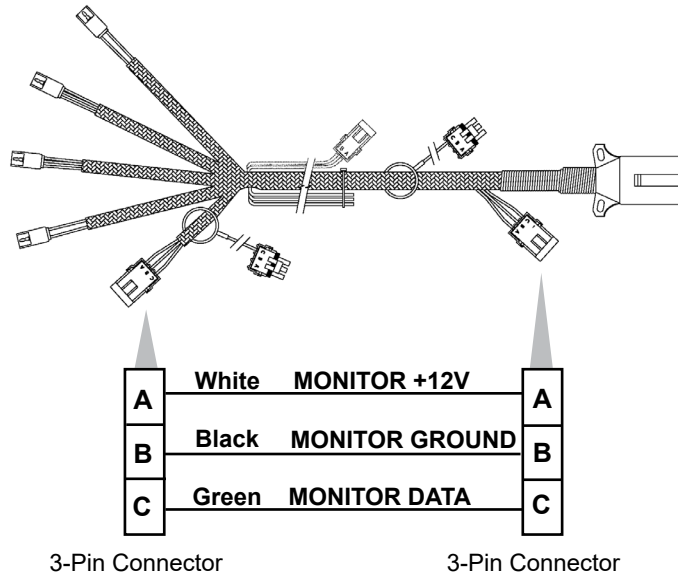

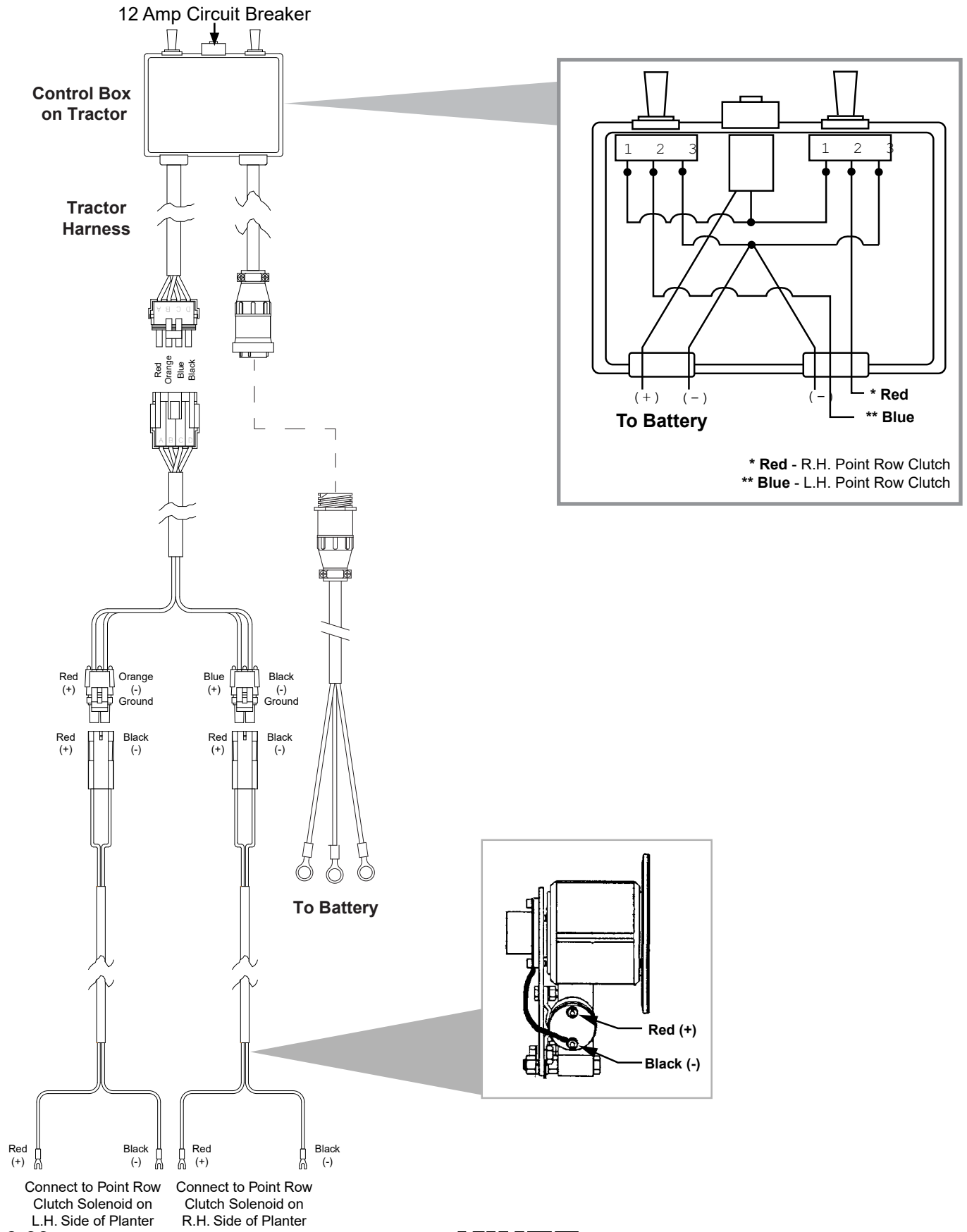

Light package meets ASABE Standards. Check with your tractor manufacturer for correct wiring harness connection to lights on your tractor.

ELECTRICAL WIRING DIAGRAMS FOR POINT ROW CLUTCHES



HYDRAULIC HOSE LIFE

 WARNING	<p>Pressurized hydraulic fluid can penetrate body tissue and result in death, serious infection, or other injuries. Fluid injected under skin must be IMMEDIATELY removed by a surgeon familiar with this type of injury. Make sure connections are tight and hoses and fittings are not damaged before applying system pressure. Leaks can be invisible. Keep away from suspected leaks. Relieve pressure before searching for leaks or performing any system maintenance.</p>
	

Proper storage of hydraulic hoses can significantly increase the life of the hoses, for a period of three to five years. After this period, service life of hoses may decrease, depending on variables such as variances in rubber materials and storage environment. Refer to the guidelines below for best practices when storing.

- Store in a clean, cool and dry area
- Avoid direct sunlight or moisture
- Do not store near high power electrical equipment
- Avoid contact with corrosive chemicals
- Avoid ultraviolet light
- Avoid areas with obvious signs of insects or rodents

Unusually long periods of storage or poor storage environment may lead to performance issues or premature failure. Always inspect all hoses prior to use for extensive wear, cuts, or holes. If such flaws are identified, replace immediately to avoid potential failure, property damage or bodily injury.

HYDRAULIC SYSTEM SCHEMATIC - PLANTER RAISING

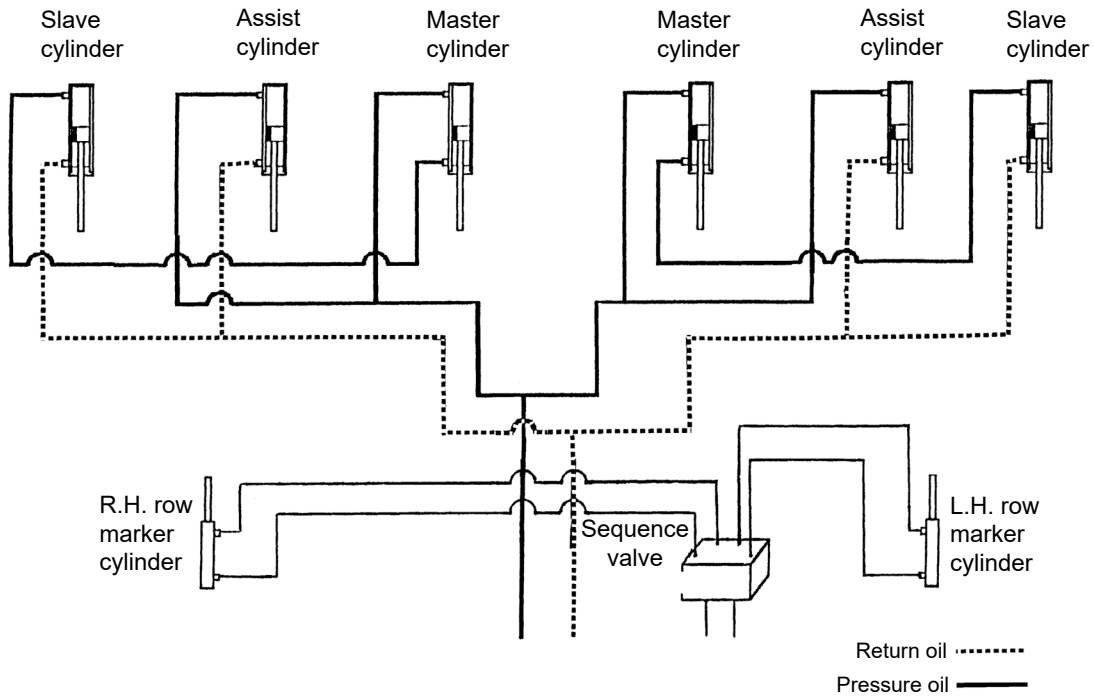

HYDRAULIC SYSTEM SCHEMATIC - PLANTER LOWERING

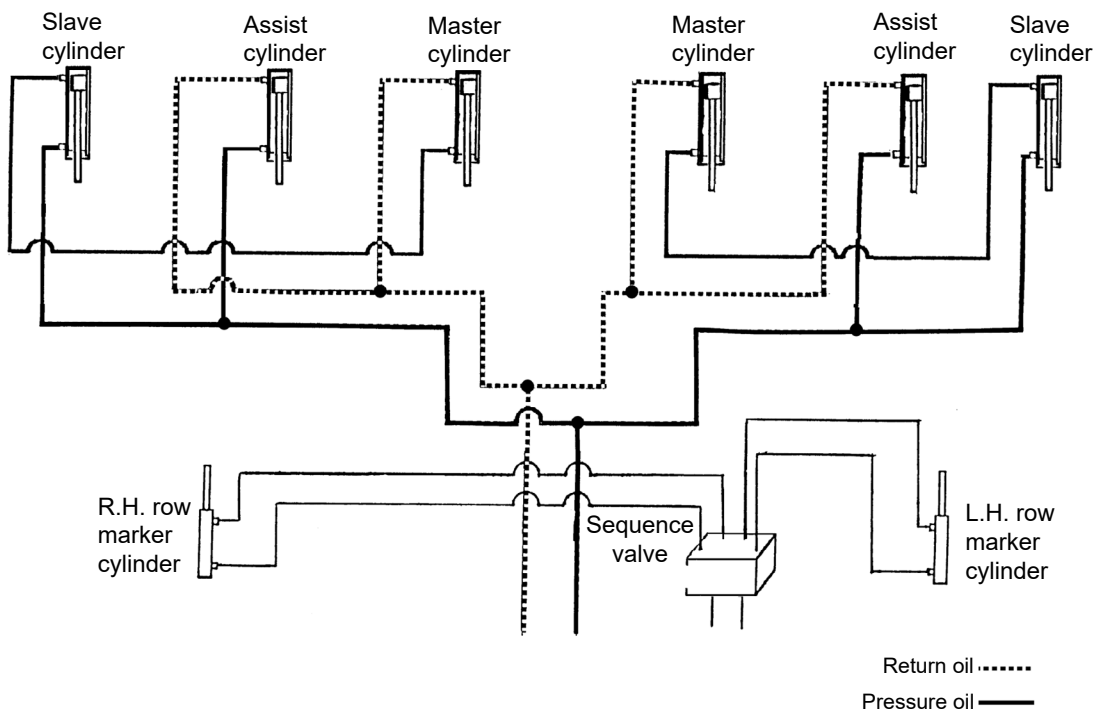

HYDRAULIC SYSTEM SCHEMATIC - OPTIONAL HYDRAULIC WING FOLD

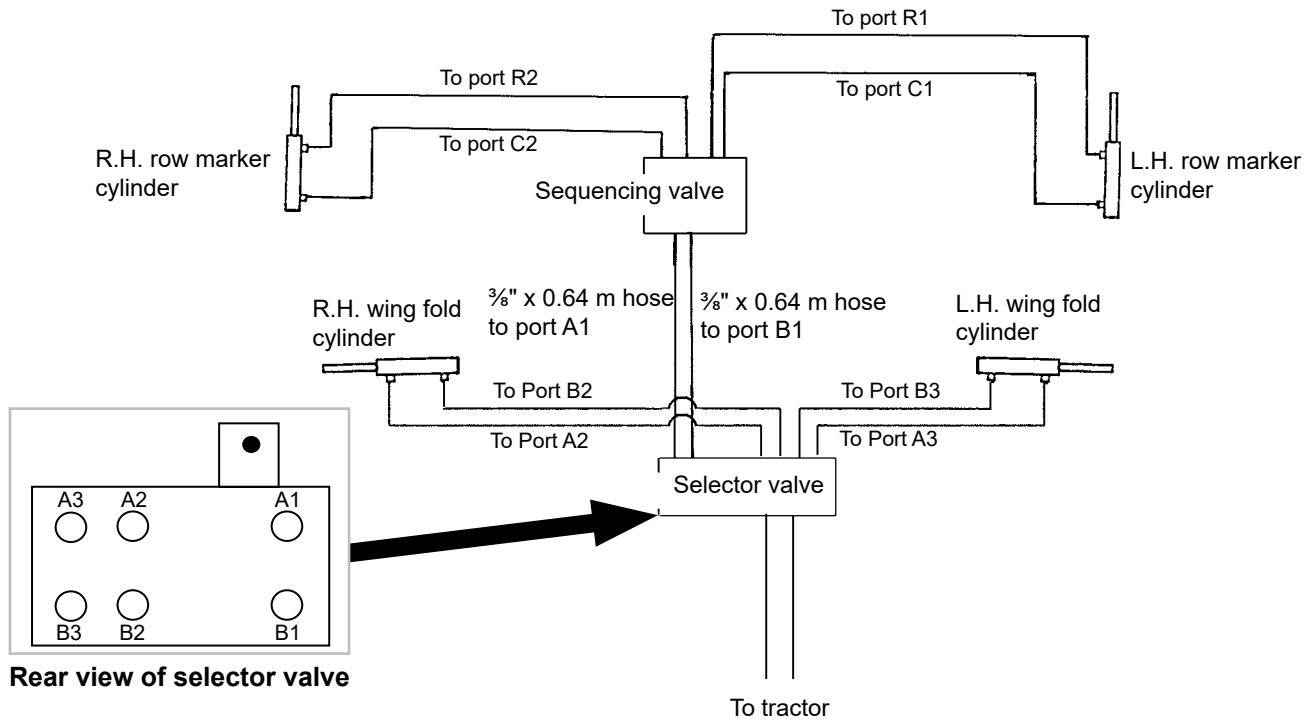

ELECTRIC CLUTCH SCHEMATIC

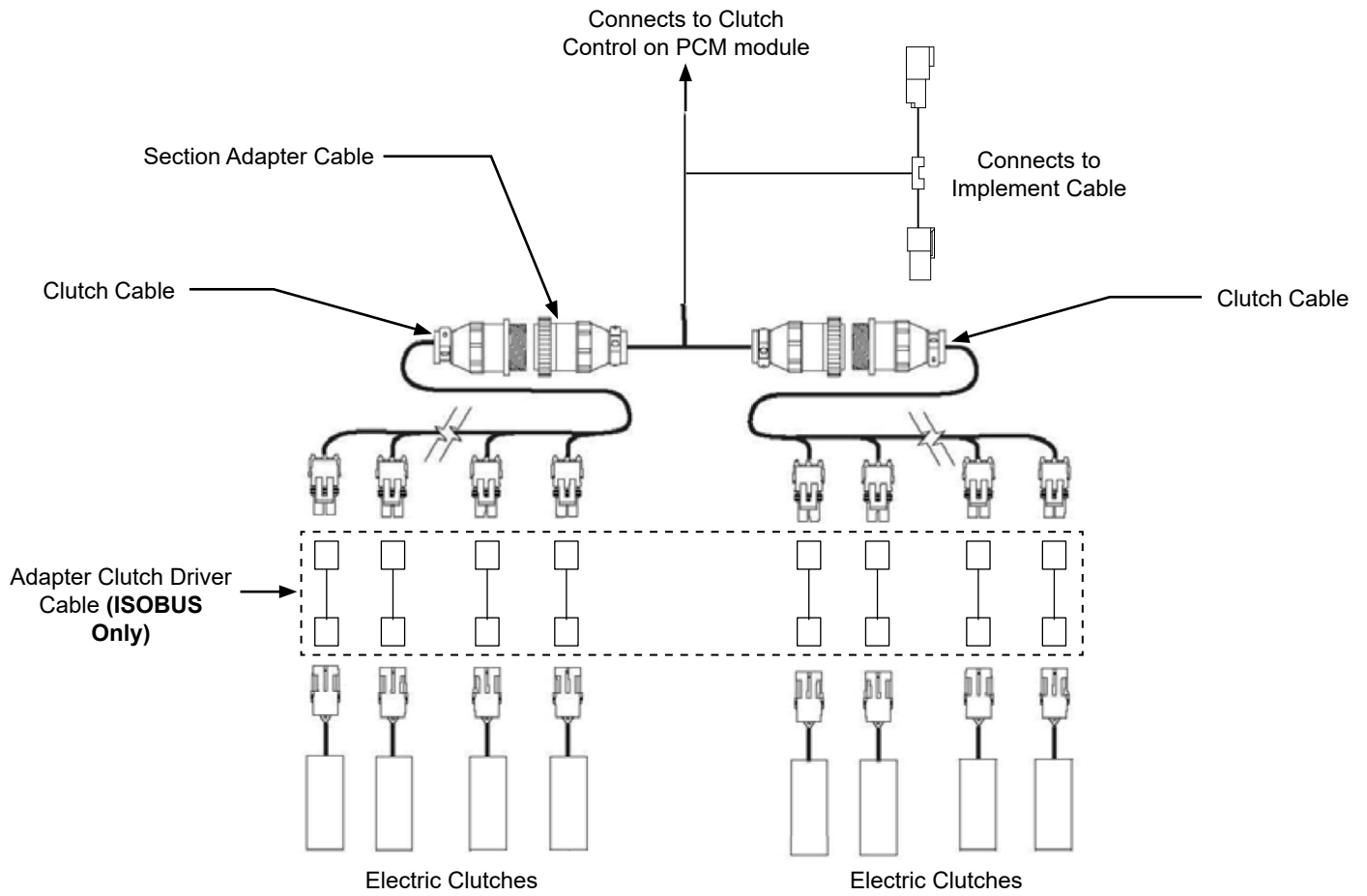

ISOBUS CAN JUMPER CABLE

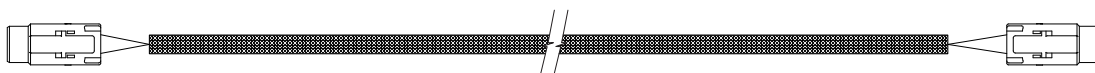

SIGNAL	CAN	WIRE/COLOR
CAN H	1	Twisted Pair Yellow
CAN L	2	Twisted Pair Green

ISOBUS CLUTCH CABLE

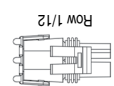
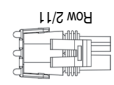
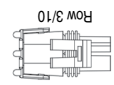
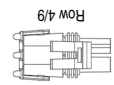
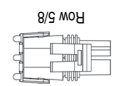
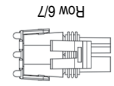
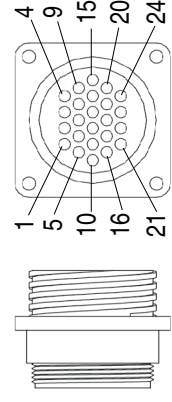
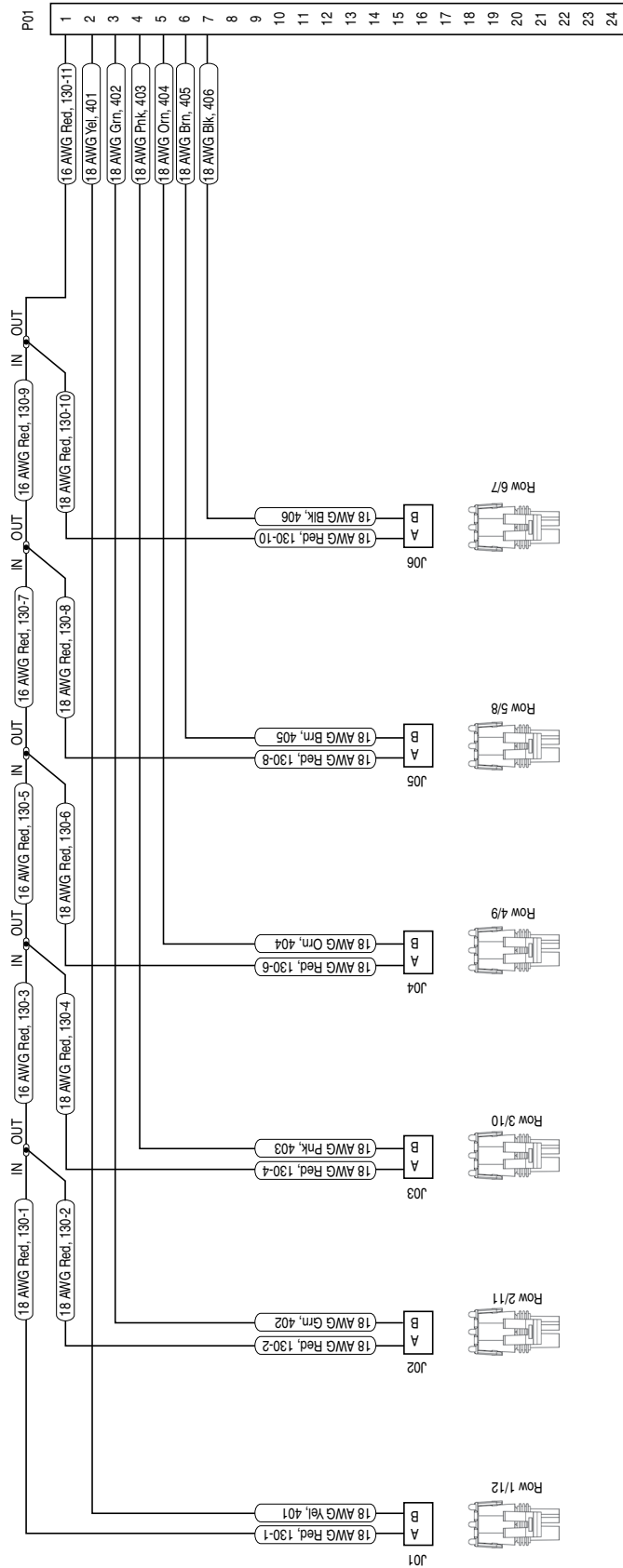

Signal	Clutch Cable	Row 8/9	Row 7/10	Row 6/11	Row 5/12	Row 4/13	Row 3/14	Row 2/15	Row 1/16
Power	1	A	A	A	A	A	A	A	A
Row 1/16	2	-	-	-	-	-	-	-	B
Row 2/15	3	-	-	-	-	-	B	-	-
Row 3/14	4	-	-	-	-	B	-	-	-
Row 4/13	5	-	-	-	B	-	-	-	-
Row 5/12	6	-	-	-	-	-	-	-	-
Row 6/11	7	-	-	B	-	-	-	-	-
Row 7/10	8	-	B	-	-	-	-	-	-
Row 8/9	9	B	-	-	-	-	-	-	-

ISOBUS IMPLEMENT CABLE

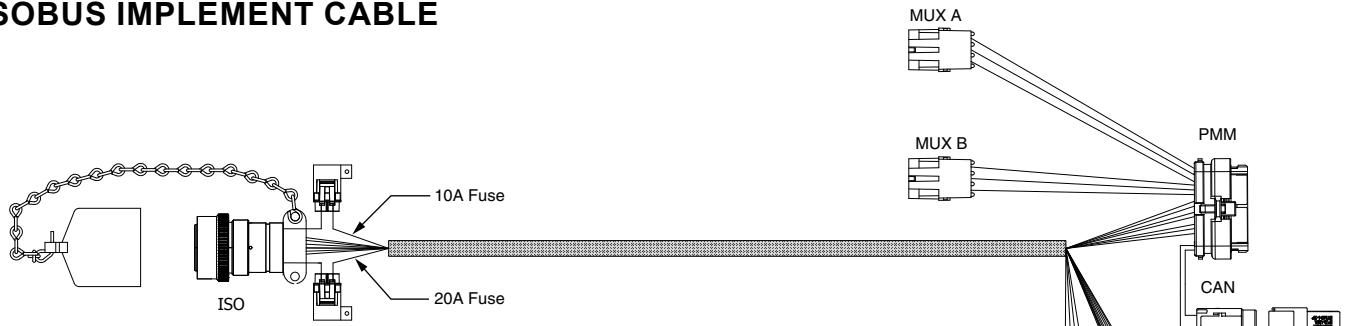

Signal	ISO	Wire/Color	PMM	TBC	PCM	CAN	Mux A	Mux B
TBC Power	6	Twisted Quad Red	-	B	-	-	-	-
TBC Ground	7	Twisted Quad Black	-	D	-	-	-	-
ISO CAN H	8	Twisted Quad Yellow	31	E	-	-	-	-
ISO CAN L	9	Twisted Quad Green	32	F	-	-	-	-
ECU Power	4	Red	4, 5, 8	-	11	-	-	-
ECU Ground	2	Black	14, 15	-	12	-	-	-
LOAD Power	3	Red	-	-	1, 2, 3, 4	-	-	-
LOAD Ground	1	Black	-	-	5, 6, 7, 8	-	-	-
MUX A Power	-	Jacketed 3-Cond White	12	-	-	-	A	-
MUX A Ground	-	Jacketed 3-Cond Black	3	-	-	-	B	-
MUX A Signal	-	Jacketed 3-Cond Green	28	-	-	-	C	-
PROP CAN H	-	Twisted Pair Yellow	34	-	-	1	-	-
PROP CAN L	-	Twisted Pair Green	35	-	-	2	-	-
MUX B Power	-	Jacketed 3-Cond White	23	-	-	-	-	A
MUX B Ground	-	Jacketed 3-Cond Black	26	-	-	-	-	B
MUX B Signal	-	Jacketed 3-Cond Green	7	-	-	-	-	C

SECTION ADAPTER CABLE

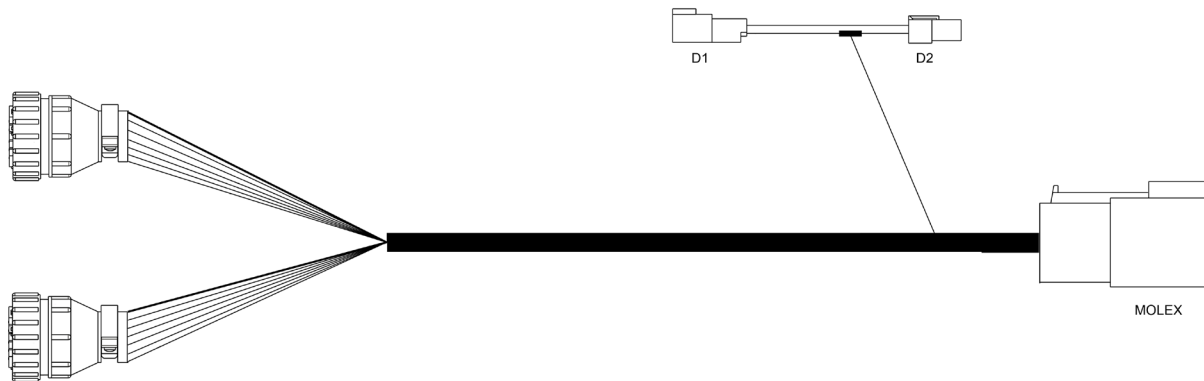

Signal	Color	AMP 1 (Left)	AMP 2 (Right)	Molex	D1	D2
High Current Power	Red	1 (16 Gauge)	1 (16 Gauge)	-	1 (12 Gauge)	1 (12 Gauge)
Ground	Black	-	-	-	2	2
Row 1, 2	Black	2, 3	-	1	-	-
Row 3, 4	Brown	4, 5	-	2	-	-
Row 5, 6	Orange	6, 7	-	3	-	-
Row 7, 8	Pink	-	6, 7	4	-	-
Row 9, 10	Green	-	4, 5	5	-	-
Row 11, 12	Yellow	-	2, 3	6	-	-

PRODUCT CONTROL MODULE CABLE

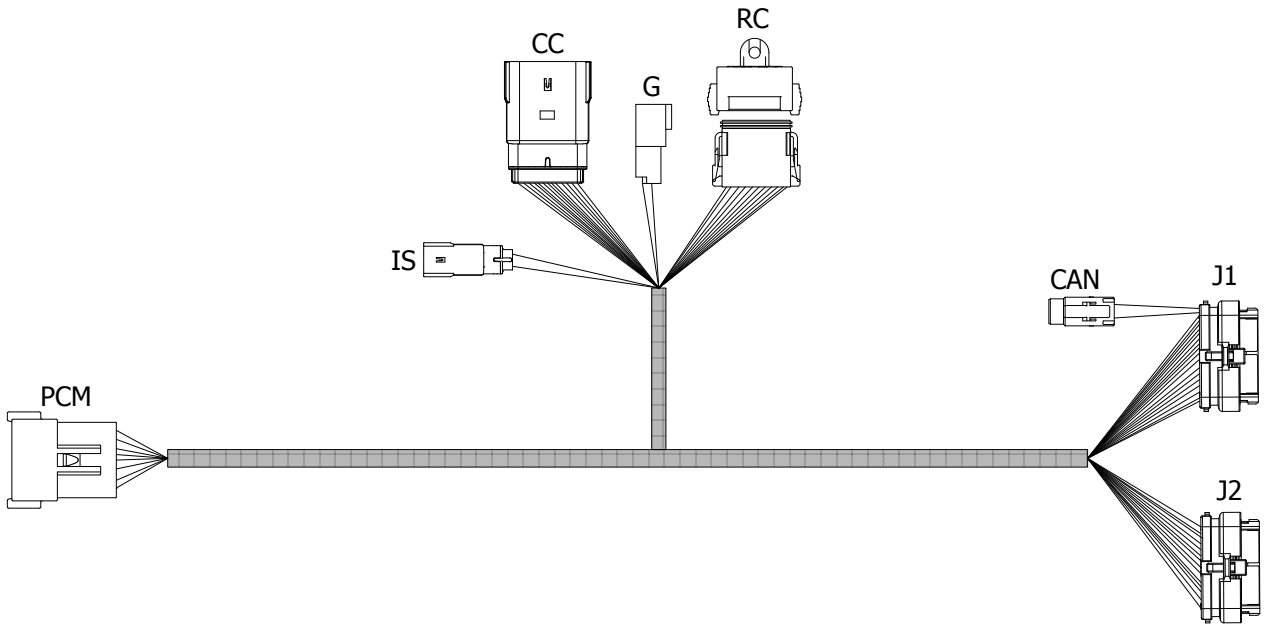

Signal	PCM	Wire/Color	J1	J2	CAN	RC	CC	IS	G
Load Power	1	Red	2	-	-	-	-	-	-
Load Power	2	Red	3	-	-	1	-	-	-
Load Power	3	Red	4	-	-	-	-	-	-
Load Power	4	Red	5	-	-	-	-	1	-
Load Ground	5	Black	-	-	-	-	-	-	1, 2
Load Ground	6	Black	14, 15	-	-	-	-	-	-
Load Ground	7	Black	16	-	-	2	-	-	-
Load Ground	8	Black	17	-	-	-	-	-	-
ECU Power	11	White/Red	11	-	-	-	-	-	-
CAN H	-	Twisted Pair Yellow	34	-	1	-	-	-	-
CAN L	-	Twisted Pair Green	33	-	2	-	-	-	-
Switch In	-	Red/Green	10	-	-	-	-	2	-
Section 1	-	White	24	-	-	-	1	-	-
Section 2	-	Green	25	-	-	-	2	-	-
Section 3	-	Orange	26	-	-	-	3	-	-
Section 4	-	Blue	27	-	-	-	4	-	-
Section 5	-	Brown	-	11	-	-	5	-	-
Section 6	-	Yellow	-	10	-	-	6	-	-
Section 7	-	Violet	-	9	-	-	7	-	-
Section 8	-	Gray	-	8	-	-	8	-	-
Section 9	-	Pink	-	7	-	-	9	-	-
Section 10	-	Tan	-	6	-	-	10	-	-
Section 11	-	Red/Green	-	5	-	-	11	-	-
Section 12	-	Black/Red	-	4	-	-	12	-	-
PWM 1 Power	-	Red/White	-	23	-	3	-	-	-
PWM 1 Ground	-	Black/White	35	-	-	4	-	-	-
PWM 2 Power	-	Red/Yellow	-	12	-	5	-	-	-
PWM 2 Ground	-	Black/Yellow	12	-	-	6	-	-	-
PWM 3 Power	-	Red/Blue	1	-	-	7	-	-	-
PWM 3 Ground	-	Black/Blue	-	24	-	8	-	-	-
Meter Speed 1	-	Green	30	-	-	9	-	-	-
Meter Speed 2	-	Green/White	29	-	-	10	-	-	-
Meter Speed 3	-	Green/Red	-	33	-	11	-	-	-

IMPLEMENT SWITCH EXTENSION CABLE

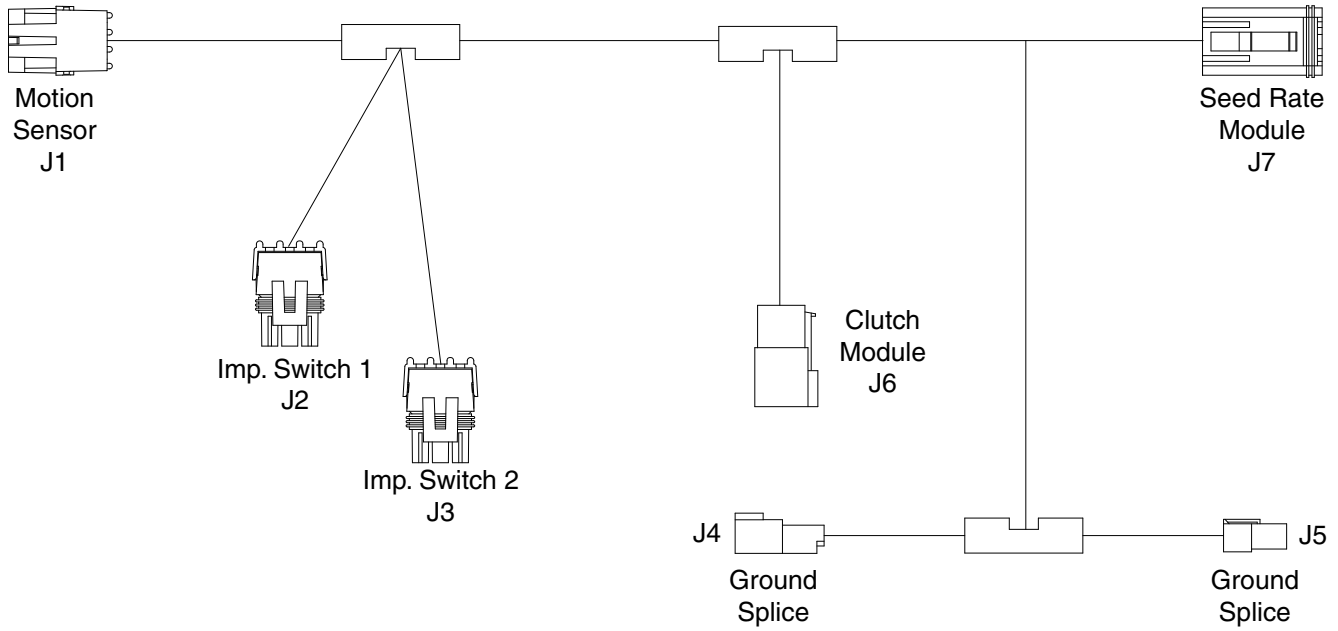

Signal	Imp. Switch 1 WP Tower 1	Imp. Switch 2 WP Tower 2	Motion Sensor WP Shroud	Color	Clutch Module Molex Recept	Seed Rate Module Deutsch Plug	Ground Splice 1	Ground Splice 2	Gauge
12V+ Power	A	A	-	Brown	1	12	-	-	16
Switch Signal	B	B	-	Green	2	10	-	-	16
Motion Signal	-	-	C	White	-	11	-	-	16
Ground	-	-	B	Black	-	6	-	-	16
12V+ Power	-	-	A	Red	-	1	-	-	16
Ground	C (Blue 16 AWG)	C (Blue 16 AWG)	-	Black	-	-	2	2	12
12V+ Power	-	-	-	Red	-	-	1	1	12

This page left blank intentionally.

CLOSING WHEEL TROUBLESHOOTING

PROBLEM	POSSIBLE CAUSE	SOLUTION
Closing wheel(s) leave severe imprint in soil.	Too much closing wheel down pressure.	Adjust closing wheel pressure.
Closing wheel(s) not firming soil around seed.	Insufficient closing wheel down pressure.	Adjust closing wheel pressure. Severe no till conditions may require use of cast iron closing wheels.
“V” closing wheel running on top of seed furrow.	Improper centering.	Align. See “V Closing Wheel Adjustment”.
Single closing wheel not directly over seed.	Improper centering.	Align. See “Covering Discs/Single Press Wheel Adjustment”.

PISTON PUMP TROUBLESHOOTING

PROBLEM	POSSIBLE CAUSE	SOLUTION
Pump hard or impossible to prime.	Valves fouled or in wrong place.	Inspect and clean valves.
	Air leak in suction line.	Repair leak.
	Pump set too low.	Adjust pump setting.
	Packing washers worn out.	Replace.
Low metering.	Valves fouled or in wrong place.	Inspect and clean valves.
	Air leak in suction line.	Repair leak.
	Pump set too low.	Adjust pump setting.
	Broken valve spring.	Replace spring.
Over metering.	Broken discharge valve spring.	Replace spring.
	Trash under valves.	Inspect and clean valves.
	Improper rate setting.	Adjust pump setting.
Leaks through when stopped.	Broken discharge valve spring.	Replace spring.
	Trash under valves.	Inspect and clean valves.
Fertilizer solution leaking under stuffing box.	Packing washers worn out.	Replace.
Pump using excessive oil.	Oil seals or o-ring worn and leaking.	Replace.
Pump operates noisily.	Crankcase components worn excessively.	Inspect and replace if necessary.

LIFT CIRCUIT OPERATION TROUBLESHOOTING

PROBLEM	POSSIBLE CAUSE	TROUBLESHOOTING*	SOLUTION
Planter raising uneven.	Master cylinder is leaking.	With turnbuckle off, raise planter slowly until master cylinder reaches end of stroke. If master cylinder is leaking it will lag behind the slave cylinder, causing the tire to squat less. If planter settles when hydraulic lever is released, check assist cylinders.	Check for contamination in rephasing valve in piston. Prior to removing rephasing valve, measure the set screw setting by turning the set screw clockwise and counting the revolutions until it bottoms out. After cleaning rephasing valve, bottom the screw out and back it out the same number of revolutions as the original setting. Replace rephasing valve and adjust as stated above or replace piston. Install seal kit. Consult your Kinze Dealer for leak testing and rephasing valve adjustment if necessary.
	Slave cylinder is leaking.	With turnbuckle off, raise and lower planter. As planter lowers, the side with leaking slave cylinder will drop rapidly. With turnbuckle on, install wheel lockups on master and assist cylinders. Retract slave cylinder and observe which tire settles. If planter settles when hydraulic lever is released, check assist cylinders.	Check for contamination in rephasing valve in piston. Prior to removing rephasing valve, measure the set screw setting by turning the set screw clockwise and counting the revolutions until it bottoms out. After cleaning rephasing valve, bottom the screw out and back it out the same number of revolutions as the original setting. Replace rephasing valve and adjust as stated above or replace piston. Install seal kit. Consult your Kinze Dealer for leak testing and rephasing valve adjustment if necessary.
Planter raising even; however, planter settles when hydraulic lever is released.	Assist cylinder is leaking.	With turnbuckle on, install lockups on the master cylinder and slave cylinders. Retract assist cylinder and observe which tire settles.	Seal on piston is leaking. Install seal kit.
*Operate hydraulics slowly to accentuate the problem. Rephase after each lowering cycle.			

ROW MARKER OPERATION TROUBLESHOOTING

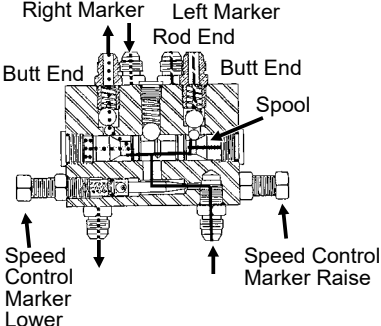
PROBLEM	POSSIBLE CAUSE	SOLUTION
<p>Same marker always operating.</p> 	<p>Spool in sequencing valve not shifting.</p>	<p>Remove spool. Inspect for foreign material, making sure all ports in spool are open. Clean and reinstall.</p>
<p>Both markers lowering and only one raising at a time.</p>	<p>Hoses from cylinders to valve connected backwards.</p>	<p>Check hosing diagram in manual and correct.</p>
<p>Both markers lower and raise at same time</p>	<p>Foreign material under check ball in sequencing valve.</p>	<p>Remove hose fitting, spring, and balls. Clean. May be desirable to remove spool and clean as well.</p>
	<p>Check ball missing or installed incorrectly in sequencing valve.</p>	<p>Disassemble and correct. See above illustration.</p>
<p>Marker (in raised position) settling down.</p>	<p>Damaged o-ring in marker cylinder or cracked piston.</p>	<p>Disassemble cylinder and inspect for damage and repair.</p>
	<p>Spool in sequencing valve not shifting completely because detent ball or spring is missing.</p>	<p>Check valve assembly and install parts as needed.</p>
	<p>Spool in sequencing valve shifting back toward center position.</p>	<p>Restrict flow of hydraulic oil from tractor to sequencing valve.</p>
<p>Neither marker will move.</p>	<p>Flow control closed too far.</p>	<p>Loosen locking nut and turn flow control adjustment bolt out or counterclockwise until desired speed is set.</p>
<p>Markers moving too fast.</p>	<p>Flow control open too far.</p>	<p>Loosen locking nut and turn flow control adjustment bolt in or clockwise until desired speed is set.</p>
<p>Sporadic marker operation speed.</p>	<p>Needle sticking open in flow control valve.</p>	<p>Remove flow control, inspect and repair or replace.</p>

POINT ROW CLUTCH TROUBLESHOOTING

PROBLEM	POSSIBLE CAUSE	SOLUTION
Neither clutch will disengage.	Circuit breaker tripped.	Press red button on control box.
	Poor terminal connection in wiring harness.	Repair or replace.
	Wiring damage in wiring harness.	Repair or replace.
	Low voltage at coil. (12 volts required)	Check battery connections.
One side of planter will not re-engage.	Shear pin in seed drive transmission sheared.	Replace with one of equal size and grade.
One clutch will not engage.	Actuator arm and plunger stuck in disengaged position.	Remove, free up and reinstall.
	Actuator arm out of adjustment.	Adjust actuator arm mounting pin in slot so that actuator arm clears stop on stop collar as shown in "Point Row Wrap Spring Clutch Inspection".
	Wrap spring broken or stretched.	Disassemble clutch and replace spring.
	Foreign substance such as oil or grease on the input or output hubs.	Disassemble clutch. Clean hubs and spring and reassemble.
	Something touching the stop collar.	Check to ensure collar is free to turn with clutch.
	Clutch assembled incorrectly.	Check clutch and diagram for correct assembly.
Clutch slipping.	Wrap spring stretched.	"Lock" clutch output shaft from turning. Place torque wrench on input shaft and rotate in direction of drive. After input shaft has rotated a short distance the wrap spring should tighten onto the input hub. If slippage occurs at less than 100 ft. lbs. replace spring. If spring still slips after installing new spring, replace input hub.
Planter will not re-engage while planter is moving forward.	Spring in actuator arm not strong enough to push arm away from stop collar when operational switch is turned to the ON position.	Remove spring and stretch spring slightly or replace. Reinstall spring. If that fails, file the stop on the stop collar slightly so that the stop is not as aggressive.
Frequent fuse burnout.	Low voltage (12 volts required).	Check power source voltage for partially discharged battery, etc.
	Damage to wiring harness.	Locate damage and repair or replace harness.
Clutch or clutches will not disengage.	Input and output shafts out of alignment.	Align input and output shafts to prevent drag.
	Input or output shaft is pushed in too far creating a coupler.	Reposition input and output shafts.

SEED METER (FINGER PICKUP) TROUBLESHOOTING

PROBLEM	POSSIBLE CAUSE	SOLUTION
One row not planting seed.	Drive release not engaged.	Engage drive release mechanism.
	Foreign material in hopper.	Clean hopper and finger carrier mechanism.
	Seed hopper empty.	Fill seed hopper.
	Row unit drive chain off of sprocket or broken.	Check drive chain.
Drive release does not engage properly.	Drive release shaft is not aligned properly with meter drive shaft.	Align drive mechanism.
Unit is skipping.	Foreign material or obstruction in meter.	Clean and inspect.
	Finger holder improperly adjusted.	Adjust to specifications. 30-34 Nm rolling torque
	Broken fingers.	Replace fingers and/or springs as required.
	Planting too slowly.	Increase planting speed to within recommended range.
Planting too many doubles.	Planting too fast.	Stay within recommended speed range.
	Loose finger holder.	Adjust to specifications. (30-34 Nm rolling torque)
	Worn brush in carrier plate.	Inspect and replace if necessary.
Overplanting.	Worn carrier plate.	Inspect and replace if necessary.
	Seed hopper additive being used.	Reduce or eliminate additive or increase graphite.
Underplanting.	Seed belt installed backwards.	Remove and install correctly.
	Weak or broken springs.	Replace.
	Spring not properly installed.	Remove finger holder and correct.
	Seed belt catching or dragging.	Replace belt.
	Brush dislodging seed.	Replace brush.
Irregular or incorrect seed spacing.	Driving too fast.	Check chart for correct speed.
	Wrong tire pressure.	Inflate tires to correct air pressure.
	Drive wheels slipping.	Reduce down pressure on row unit down force springs.
	Wrong sprockets.	Check seed rate charts for correct sprocket combinations.
Seed spacing not as indicated in charts.	Wrong tire pressure.	Inflate tires to correct air pressure.
	Inconsistent seed size.	Perform field check and adjust sprockets accordingly.
	Wrong sprockets.	Check chart for correct sprocket combination.
	Charts are approximate.	Slight variations due to wear in meter components and tire slippage due to field conditions may produce seed spacing variations.
	Stiff or worn drive chains.	Replace chains.
Scattering of seeds.	Planting too fast.	Reduce planting speed.
	Seed tube improperly installed.	Check seed tube installation.
	Seed tube worn or damaged.	Replace seed tube.
Seed tubes and/or openers plugging.	Allowing planter to roll backward when lowering.	Lower planter only when tractor is moving forward.
Inconsistent seed depth.	Rough seed bed.	Adjust down pressure springs. Reduce planting speed.
	Partially plugged seed tube.	Inspect and clean.
	Seed tube improperly installed.	Install properly.

SEED METER (BRUSH-TYPE) TROUBLESHOOTING

PROBLEM	POSSIBLE CAUSE	SOLUTION
Low count.	Meter RPM too high.	Reduce planting speed.
	Seed sensor not picking up all seeds dropped.	Clean seed tube. Switch meter to different row. If problem stays with same row, replace sensor.
	Lack of lubrication causing seeds not to release from disc properly.	Use graphite or talc as recommended.
	Seed size too large for seed disc.	Switch to smaller seed or appropriate seed disc. See "Brush-Type Seed Meter" for proper seed disc for size of seed being used.
	Seed treatment buildup in meter.	Reduce amount of treatment used and/or thoroughly mix treatment with seed. Add talc.
Low count at low RPM and higher count at higher RPM.	Foreign material lodged in upper brush.	Remove seed disc and remove foreign material from between brush retainer and bristles. Clean thoroughly.
	Worn upper brush.	Replace. See "Maintenance".
Low count at higher RPM and normal count at low RPM.	Seed disc worn in the agitation groove area.	Replace disc. See "Maintenance".
High count.	Seed size too small for seed disc.	Switch to larger seed or appropriate seed disc.
	Incorrect seed rate transmission setting.	Reset transmission. Refer to proper rate chart in "Machine Operation" section of manual.
	Upper brush too wide (fanned out) for small seed size.	Replace upper brush.
High count. (Milo/Grain Sorghum)	Incorrect brush retainer.	Make sure GD8237 brush retainer is installed to keep upper brush from fanning out.
Upper brush laid back.	Seed treatment buildup on brush.	Remove brush. Wash with soap and water. Dry thoroughly before reinstalling. See "Maintenance".
	Buildup of foreign material at base of brush.	Remove brush retainer and brush. Clean thoroughly. Reinstall.

This page left blank intentionally.