



EUROPEAN DECLARATION OF CONFORMITY

Kinze Manufacturing
2172 M Avenue
Williamsburg, IA 53261

Kinze Europe UAB
Guopstu k., Senuju Traku sen
LT-21148 Traku r., Lithuania

We, Kinze Manufacturing and Kinze Europe UAB declare, under our sole responsibility, the following products – agricultural planter models 3005, 3035, 3115, 3145, 3205, 3505, 3605, 3665, 3705, 4805, and 4905 – to which this declaration relates, are in conformity with the applicable provisions of the following standards, other normative documents and Directives, as appropriate by version and model:

2006/42/EC; EN 1037:1995+A1:2008; EN ISO 13850:2008; EN ISO 13857:2008; EN 349:1993+A1:2008; EN 547-1:1996+A1:2008; EN 547-2:1996+A1:2008; EN 547-3:1996+A1:2008; EN ISO 13732-1:2008; EN 614-1:2006+A1:2009; EN 614-2:2000+A1:2008; EN 953:1997+A1:2009; EN ISO 13849-1:2008; EN ISO 13849-2:2012; EN ISO 4254-1; EN ISO 12100:2010; EN ISO 4413:2010.

The Technical Construction File is maintained at: Kinze Manufacturing, Inc., 2172 M Avenue, Williamsburg, Iowa, USA, 52361-0806.

The authorized representative located within the community is: Edvardas Melys, Kinze Europe UAB, Guopstu k., Senuju Traku sen, LT-21148 Traku r., Lithuania.

Place of Issue: Kinze Manufacturing Inc., Williamsburg, Iowa, USA.

Date of Issue: 20200821 | August 21, 2020

Signed on behalf of Kinze Manufacturing Inc. and Kinze Europe UAB:

Jay D. Grimes

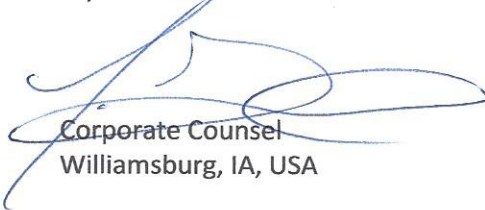

Corporate Counsel
Williamsburg, IA, USA



Kinze Manufacturing, Inc.



СЕРТИФИКАТ СООТВЕТСТВИЯ

№ ЕАЭС RU C-US.AД07.B.02342/20

Серия **RU** № **0225035**

ОРГАН ПО СЕРТИФИКАЦИИ Орган по сертификации Общество с ограниченной ответственностью «Центр Сертификации «ВЕЛЕС». Место нахождения (адрес юридического лица): 195009, РОССИЯ, город Санкт-Петербург, улица Академика Лебедева, дом 12, корпус 2, литера А, этаж 2, комната 26. Адрес места осуществления деятельности: 190068, РОССИЯ, город Санкт-Петербург, переулок Никольский, дом 4 литер А, помещение 8Н. Уникальный номер записи об аккредитации в реестре аккредитованных лиц № RA.RU.10АД07. Дата решения об аккредитации: 24.03.2016. Телефон: +74952211810 Адрес электронной почты: info@velessert.ru

ЗАЯВИТЕЛЬ ОБЩЕСТВО С ОГРАНИЧЕННОЙ ОТВЕТСТВЕННОСТЬЮ "МИР ТЕХНОЛОГИЙ"
Место нахождения (адрес юридического лица) и адрес места осуществления деятельности: 117042, Россия, город Москва, улица Адмирала Руднева, дом 4, этаж 6, помещение IV, офис 613
Основной государственный регистрационный номер 1187746469096.
Телефон: 89154152183. Адрес электронной почты: MirTekhnology@gmail.com

ИЗГОТОВИТЕЛЬ KINZE Manufacturing, Inc.
Место нахождения (адрес юридического лица): Соединенные Штаты, 2172 M Avenue, Williamsburg, IA 52631-0806
Филиал изготовителя: KINZE Europe, UAB Литва, Guopstu kelias 17, Guopstos, LT-21148 Traku rajonas

ПРОДУКЦИЯ Машины сельскохозяйственные: сеялка точного высева торговой марки KINZE, моделей: 3000, 3005, 3030, 3035, 3110, 3115, 3140, 3145, 3200, 3205, 3500, 3505, 3600, 3605, 3660, 3665, 3700, 3705, 4700, 4705, 4800, 4805, 4900, 4905.
Продукция изготовлена в соответствии с Директивой 2006/42/ЕС «Машины и механизмы».

Серийный выпуск

КОД ТН ВЭД ЕАЭС 8432311100

СООТВЕТСТВУЕТ ТРЕБОВАНИЯМ

Технического регламента Таможенного союза "О безопасности машин и оборудования" (ТР ТС 010/2011)

СЕРТИФИКАТ СООТВЕТСТВИЯ ВЫДАН НА ОСНОВАНИИ

протокола испытаний № 1023/3АТС-2020 от 27.10.2020 года, выданного Испытательной лабораторией «АвтоТракторные Средства» Общество с ограниченной ответственностью «ПРОММАШ ТЕСТ» (регистрационный номер аттестата аккредитации RA.RU.21НА71) акта анализа состояния производства от 21.09.2020 года, выданного Органом по сертификации Общество с ограниченной ответственностью «Центр Сертификации «ВЕЛЕС» обоснования безопасности; руководства по эксплуатации; паспорта

Схема сертификации: 1с

ДОПОЛНИТЕЛЬНАЯ ИНФОРМАЦИЯ ГОСТ Р 53489-2009 "Система стандартов безопасности труда. Машины сельскохозяйственные навесные и прицепные. Общие требования безопасности" разделы 4 и 5. Срок службы, срок и условия хранения указаны в эксплуатационной документации, приложенной к изделию.

СРОК ДЕЙСТВИЯ С 28.10.2020 **ПО** 27.10.2025
ВКЛЮЧИТЕЛЬНО

Руководитель (уполномоченное
лицо) органа по сертификации

Эксперт (эксперт-аудитор)
(эксперты (эксперты-аудиторы))

Родзиков Галина Александровна (Ф.И.О.)
Киреевко Константин Борисович (Ф.И.О.)



This page left blank intentionally.

TO THE DEALER

Predelivery service includes assembly, lubrication, adjustment and test. This service helps to ensure planter is delivered to retail customer/end user ready for field use.

PREDELIVERY CHECKLIST

Use the following checklist after planter is completely assembled to inspect planter. Check off each item as it is found satisfactory or after proper adjustment is made.

- Row units properly spaced and optional attachments correctly assembled.
- Row marker assemblies installed and adjusted at each end of planter.
- Vacuum meter and bulk fill components properly installed (as applicable)
- All grease fittings in place and lubricated.
- All working parts are moving freely. Bolts are tight and cotter pins are spread.
- All drive chains properly tensioned and aligned.
- Check for oil leaks and proper hydraulic operation.
- Hydraulic hoses are routed correctly to prevent damage to hoses.
- Inflate tires to specified air pressure. Tighten wheel lug bolts and lug nuts to specified torque.
- All safety decals correctly located and legible as shown in Parts Manual. Replace if damaged.
- All reflective decals and SMV sign located as shown in Parts Manual and visible when planter is in transport position.
- Safety/warning lights correctly installed and working properly.
- Paint all parts scratched in shipment or assembly.
- All safety lockup devices are on planter and correctly located.
- Seed meters performance checked on test stand. Vacuum fan, analog gauge, control box, and hoses installed.
- Auxiliary safety chain is properly installed and hardware is torqued to specification.
- Vacuum fan PTO-driven pump is attached correctly to the tractor. Oil reservoir is filled to capacity and system is inspected for leaks. (If Applicable)

Planter has been thoroughly checked and to the best of my knowledge is ready for delivery to the customer.

(Signature Of Set-Up Person/Dealer Name/Date)

OWNER REGISTER

Name _____ Delivery Date _____

Street Address _____ Model No. 3505 Serial No. _____

City, State/Province _____ Dealer Name _____

ZIP/Postal Code _____ Dealer No. _____

DELIVERY CHECKLIST

Use the following checklist when planter is delivered as a reminder of important information which should be conveyed to retail customer/end user. Check off each item as it is fully explained.

- Check for proper operation of vacuum fan and PTO driven pump (If Applicable) with tractor to be used with planter.
- Life expectancy of this or any other machine is dependent on regular lubrication as directed in the Operator Manual.
- All applicable safety precautions.
- Along with retail customer/end user, check reflective decals and SMV sign are clearly visible with planter in transport position and attached to tractor. Check safety/warning lights are in working condition. Tell retail customer/end user to check federal, state/provincial, and local regulations before towing or transporting on a road or highway.
- Give Operator Manual, Parts Manual, and all Instruction Sheets to retail customer/end user and explain all operating adjustments.
- Read warranty to retail customer/end user.
- Complete Warranty and Delivery Report form.

To the best of my knowledge this machine has been delivered ready for field use and customer has been fully informed as to proper care and operation.

(Signature Of Delivery Person/Dealer Name/Date)

AFTER DELIVERY CHECKLIST

The following is a list of items we suggest to check during the first season of use of the equipment.

- Check planter performance with retail customer/end user.
- Check performance of vacuum seed metering system with retail customer/end user.
- Review importance of proper maintenance and adherence to all safety precautions with retail customer/end user.
- Check for parts that may need to be adjusted or replaced.
- Check all safety decals, reflective decals, and SMV sign are correctly located as shown in the Parts Manual and that decals are legible. Replace if damaged or missing.
- Check safety/warning lights are working properly.

(Signature Of Follow-Up Person/Dealer Name/Date)

**All registrations must be submitted online at "business.kinze.com" within 5 business days of delivery.
Retain a copy of this form for auditing purposes.**

Tear Along Perforation

OVERVIEW

To The Owner	1-1
Warranty	1-3
General Information	1-4
Specifications	1-5
General Safety Rules	1-7
Safety Instructions, Signs, and Decals	1-8

MACHINE OPERATION

Initial Preparation	2-1
Tires Preparation	2-1
Tractor Requirements	2-2
Row Marker Safety Lockup	2-2
Safety Lockup Pin	2-3
Stroke Limiter Pin (Conventional Only)	2-3
Transport Latch Locking Pin	2-4
Hitch Length Adjustment	2-4
Jack Stand	2-5
Hydraulic Operation - Conventional	2-5
Hydraulic Operation - Bulk Fill	2-8
PTO Pump Drive And Oil Cooler Option	2-10
Tractor Preparation and Hookup	2-14
Level Planter	2-16
Cylinder Information	2-17
Hydraulic Hose Information	2-18
Towing Planter	2-23
Planting Speed	2-23
Contact Drive Spring Adjustment	2-24
Seed Rate Transmission Adjustment	2-24
Shear Protection	2-25
Wrap Spring Wrench	2-26
Contact Wheel Drive Sprockets	2-26
Row Marker Speed Adjustment	2-27
Even-Row Push Row Unit	2-27
Row Marker Adjustments	2-28
Row Marker Even-Row Length Adjustment	2-29
Vacuum Meter System	2-30
Analog Vacuum or Pressure Gauge	2-30
Bulk Fill System	2-31
Bulk Fill Entrainer Access	2-32
Bulk Fill Tanks - Clean Out	2-32
Ridge Planting	2-33
Tire Scraper	2-33
Auxiliary Work Lights Package	2-33
Rear Trailer Hitch	2-34
Field Test	2-35
Check Seed Population	2-35

Determining Liters Per Hectare	2-36
Granular Chemical Application Field Check	2-37
Water Tank	2-38

ROW UNIT OPERATION

Planting Depth	3-1
"V" Closing Wheel Adjustment (Rubber or Cast Iron)	3-1
Seed Hoppers	3-2
Seed Meter Drive Release	3-2
Row Unit Extension Brackets	3-2
Row Unit Chain Routing	3-3
Quick Adjustable Down Force Springs Option	3-4
Pneumatic Down Pressure Package (PDP) Option	3-5
Field Operation	3-6
Split Row Push Unit Lockups	3-7
Split Row Push Row Unit Clutch Sprocket	3-9
Split Row Push Row Unit Vacuum Hose Shutoff	3-9
Vacuum Settings	3-10
Wheat Disc Wiper Installation	3-12
Seed Meter Cleanout	3-14
Additives	3-16
Rapeseed Planting Section	3-18
Vacuum Meter Insulation for Rapeseed Planting	3-20
Row Unit Mounted Residue Wheel	3-22
Row Unit Mounted No Till Coulter	3-23
Coulter Mounted Residue Wheels	3-23
Granular Chemical Hopper and Drive	3-24
Granular Chemical Banding Options	3-25
Spiked Closing Wheel	3-26

FERTILIZER

System Overview	4-1
Notched Single Disc Openers	4-1
Depth/Gauge Wheel Attachment for Notched Single Disc Fertilizer Opener	4-2
HD Single Disc Fertilizer Opener	4-3
Dry Fertilizer Attachment	4-5
Cleaning	4-6
Liquid Fertilizer Attachment	4-7
Optional Piston Pump	4-8
LIQUID FERTILIZER SYSTEM SCHEMATICS	4-14
Row Flow meter	4-21
Row Flow Meter Cleanout	4-22
Row Flow meter Jet Orifice Removal	4-23
Row Flow meter Jet Orifice Installation	4-25
Flow meter Strainer and Orifice Cleaning and/or Replacement	4-27

Orifice Configuration Rates 4-29
 Pump Clean Out and Storage 4-31
 In Furrow 4-34
 Liquid fertilizer 3-way distribution valves 4-35
 Valve functions for each handle position: 4-35
 Liquid Fertilizer Sensors 4-36
 Fertilizer Pump Troubleshooting 4-37
 Fertilizer System Troubleshooting 4-38

RATE CHARTS 5-1

LUBRICATION AND MAINTENANCE

Lubrication 6-1
 Sealed Bearings 6-1
 Wrap Spring Wrench Assembly 6-1
 Drive Chains 6-2
 Split Row Push Unit Lockups 6-3
 Bushings 6-4
 Grease Fittings 6-4
 Base Machine 6-5
 Dry Fertilizer Attachment 6-6
 Fertilizer Openers 6-6
 PTO pump shaft and Tractor pto shaft 6-7
 Center Post 6-9
 Wheel Bearings 6-9
 Liquid Fertilizer Piston Pump Crankcase Oil Level 6-10
 PTO Pump Shaft Coupling (PTO Pump Drive and Oil Cooler Option) 6-10
 Mounting Bolts and Hardware 6-11
 Tire Pressure 6-13
 Chain Tension Adjustment 6-13
 Pneumatic Down Pressure Air Compressor Tank 6-13
 Vacuum Seed Meter Maintenance 6-14
 Seed Meter Cleanout 6-15
 Gauge Wheel Adjustment 6-15
 Gauge Wheel Arm Bushing/Seal Replacement 6-16
 Gauge Wheel Arm Pivot Spindle Replacement 6-17
 15" Seed Opener Disc Blade/Bearing Assembly 6-18
 Seed Tube Guard/Inner Scraper 6-20
 Row Unit Mounted No Till Coulter 6-21
 Coulter Mounted Residue Wheels 6-21
 Spiked Closing Wheel 6-22
 Granular Chemical Attachment 6-22
 Wear Pad Adjustment/Replacement 6-23
 Row Marker Sequencing/Flow Control Valve Inspection 6-24
 PTO Pump Drive and Oil Cooler Option 6-25
 Check Valve Inspection 6-25

Row Marker Bearing Lubrication or Replacement 6-26
 Wheel Bearing Repack or Replacement 6-27
 Fertilizer Check Valve Cleaning and Repair 6-27
 Piston Pump Maintenance 6-28
 Piston Pump Storage 6-29
 Preparing Planter for Storage 6-30
 Hydraulic Hose Life 6-31
 Vacuum Planter Hydraulic System 6-32
 Vacuum Bulk Fill Planter Hydraulic System 6-33
 Vacuum Planter With PTO Option Hydraulic System 6-34
 Vacuum Bulk Fill Planter With PTO Option Hydraulic System 6-35
 Vacuum Blue Drive Conventional Planter Without PTO Option Hydraulic System 6-36
 Vacuum Blue Drive Bulk Fill Planter Without PTO Option Hydraulic 6-37
 System 6-37
 Vacuum Blue Drive Blue Vantage Conventional Planter With PTO Option Hydraulic System 6-38
 Vacuum Blue Drive Blue Vantage Bulk Fill Planter With PTO Option Hydraulic System 6-39
 Hydraulic Diagram - Vacuum Fan Motor System 6-41
 Battery Care 6-42
 Electrical Wiring for LightS Package 6-43
 Power Pack Wiring Diagram (Blue Drive) 6-43
 Cables and Harnesses 6-44

TROUBLESHOOTING



Bulk Fill Troubleshooting 7-1
 Closing Wheel Troubleshooting 7-1
 Piston Pump Troubleshooting 7-2
 PTO Pump Drive and Oil Cooler Option Troubleshooting 7-2
 Row Marker Operation Troubleshooting 7-3
 Solenoid Valve 7-3
 Vacuum Seed Meter 7-4

Kinze Manufacturing, Inc. thanks you for your patronage. We appreciate your confidence in Kinze farm machinery. Your Kinze planter has been carefully designed to provide dependable operation in return for your investment.

This manual has been prepared to aid you in the operation and maintenance of the planter. It should be considered a permanent part of the machine and remain with the machine when you sell it.

It is the responsibility of the user to read and understand the Operator Manual in regards to safety, operation, lubrication and maintenance before operation of this equipment. It is the user's responsibility to inspect and service the machine routinely as directed in the Operator Manual. We have attempted to cover all areas of safety, operation, lubrication and maintenance; however, there may be times when special care must be taken to fit your conditions.

Throughout this manual the symbol  and the words **DANGER**, **WARNING**, and **CAUTION** are used to call attention to safety information that if not followed, will or could result in death or injury. **NOTICE** and **NOTE** are used to call your attention to important information. The definition of each of these terms follows:

 DANGER	<p>Indicates an imminently hazardous situation that, if not avoided, will result in death or serious injury. This signal word is to be limited to the most extreme situations, typically for machine components which, for functional purposes, cannot be guarded.</p>
 WARNING	<p>Indicates a potentially hazardous situation that, if not avoided, could result in death or serious injury, and includes hazards that are exposed when guards are removed. It may also be used to alert against unsafe practices.</p>
 CAUTION	<p>Indicates a potentially hazardous situation that, if not avoided, may result in minor or moderate injury. It may also be used to alert against unsafe practices.</p>
NOTICE	<p>Used to address safety practices not related to personal injury.</p>

NOTE: Special point of information or machine adjustment instructions.

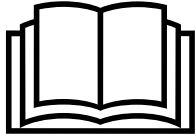

Improperly operating or working on this equipment could result in death or serious injury. Read and follow all instructions in Operator Manual before operating or working on this equipment.



Some photos in this manual may show safety covers, shields, or lockup devices removed for visual clarity. **NEVER OPERATOR OR WORK ON** machine without all safety covers, shields, and lockup device in place as required.

NOTE: Some photos in this manual may have been taken of prototype machines. Production machines may vary in appearance.

NOTE: Some photos and illustrations in this manual show optional attachments installed. Contact your Kinze Dealer for purchase of optional attachments.

The Kinze Limited Warranty for your new machine is stated on the retail purchaser's copy of the Warranty And Delivery Receipt form. Additional copies of the Limited Warranty can be obtained through your Kinze Dealer.

Warranty, within the warranty period, is provided as part of Kinze's support program for registered Kinze products which have been operated and maintained as described in this manual. Evidence of equipment abuse or modification beyond original factory specifications will void the warranty. Normal maintenance, service and repair is not covered by Kinze warranty.

To register your Kinze product for warranty, a Warranty And Delivery Receipt form must be completed by the Kinze Dealer and signed by the retail purchaser, with copies to the Dealer, and to the retail purchaser. Registration must be completed and submitted to Kinze Manufacturing, Inc. within 5 business days of delivery of the Kinze product to the retail purchaser. Kinze Manufacturing, Inc. reserves the right to refuse warranty on serial numbered products which have not been properly registered.

If service or replacement of failed parts which are covered by the Limited Warranty are required, it is the user's responsibility to deliver the machine along with the retail purchaser's copy of the Warranty And Delivery Receipt to the Kinze Dealer for service. Kinze warranty does not include cost of travel time, mileage, hauling or labor. Any prior arrangement made between the Dealer and the retail purchaser in which the Dealer agrees to absorb all or part of this expense should be considered a courtesy to the retail purchaser.

Kinze warranty does not include cost of travel time, mileage, hauling, or labor.

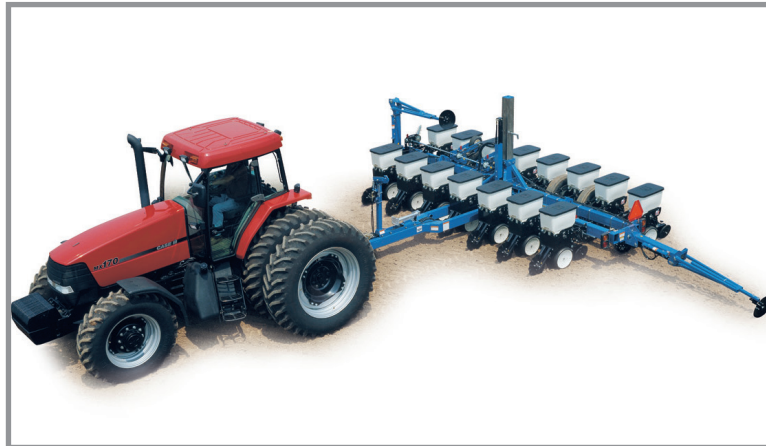

Model 3505 with Row Hoppers



Model 3505 Bulk Fill

GENERAL INFORMATION

This manual covers all production years of the Model 3505 70 cm planter. Contact your Kinze dealer for additional options which may be available for your specific model year planter.

Information in this manual was current at time of printing. However, due to Kinze's ongoing product improvement, production changes may cause your machine to appear slightly different in detail. Kinze Manufacturing, Inc. reserves the right to change specifications or design without notice and without incurring obligation to install the same on machines previously manufactured. To obtain the most recent version of your publication, please contact your Kinze dealer.

Right hand (R.H.) and left hand (L.H.), as used throughout this manual, are determined by facing in direction machine travels in use, unless otherwise stated.

TOOLS REQUIRED

Hardware Size / Tool Required			
$1/4" = 7/16"$	$7/16" = 5/8"$ (nut for $7/16"$ hardware uses $11/16"$ tool)	$3/4" = 11/8"$	$1 1/4" = 1 7/8"$
$5/16" = 1/2"$	$1/2" = 3/4"$	$7/8" = 1 5/16"$	$1 1/2" = 2 1/4"$
$3/8" = 9/16"$	$5/8" = 1 5/16"$	$1" = 1 1/2"$	

Planter	3505 70cm 8 Row Y Hitch	
Specifications	Vacuum Bulk Fill	Vacuum
Number of rows	8	8
Row spacing	70 cm	70 cm
Weight Empty	3700 kg	3200 kg
Transport Height	3,7 m	3,4 m
Transport Length	7,6 m	7,6 m
Transport Width	3,1 m	3,1 m
Planting Height	2,6 m	2,5 m
Planting Length	6,1 m	
Planting Width	6,1 m	
Seed Capacity	1762 l	496 l
Transport Tires	Four 7.50" x 20" 8 ply rib implement tires w/center groove - Inflate to 40 PSI (~276 kPa)	
Contact Drive Tires	Two 4.10" x 6" spring-loaded contact drive tires. - Inflate to 50 PSI (~345 kPa)	
Field Lift	One center post lift cylinder. (Front or rear mount.)	
Row Markers	Two-fold low profile with 41 cm concave, solid blades and cast iron hubs.	
NOTE: Specifications are for base machine. Additional options could affect the figures.		

Planter	3505 70cm 8 Row T Hitch	
Specifications	Vacuum	Vacuum Bulk Fill
Number of rows	8	8
Row spacing	70 cm	70 cm
Weight Empty	3300 kg	3800 kg
Transport Height	3,4 m	3,7 m
Transport Length	7,6 m	7,6 m
Transport Width	3,1 m	3,1 m
Planting Height	2,5 m	2,6 m
Planting Length	6,1 m	
Planting Width	6,1 m	
Seed Capacity	496 l	1762 l
Transport Tires	Four 7.50" x 20" 8 ply rib implement tires w/center groove - Inflate to 40 PSI (~276kPa)	
Contact Drive Tires	Two 4.10" x 6" spring-loaded contact drive tires. - Inflate to 50 PSI (~345 kPa)	
Field Lift	One center post lift cylinder. (Front or rear mount.)	
Row Markers	Two-fold low profile with 41 cm concave, solid blades and cast iron hubs.	
NOTE: Specifications are for base machine. Additional options could affect the figures.		

Tractor Hydraulic Requirements - 8 Row Planters (Conventional)			
Configuration	Requirements		Description
Base machine with vacuum meters	3 SCV	20 gpm (~76 l/min)	#1 SCV: Planter lift
			#2 SCV: Markers/fold (manual selector valve)
			#3 SCV: Vacuum fan
Base machine with vacuum meters and Blue Drive	4 SCV	30 gpm (~113 l/min)	#1 SCV: Planter lift
			#2 SCV: Markers/fold (manual selector valve)
			#3 SCV: Vacuum fan
			#4 SCV: Power Pack
Base machine with vacuum meters and tractor mounted PTO pump	2 SCV	10 gpm (~38 l/min)	#1 SCV: Planter lift
			#2 SCV: Markers/fold (manual selector valve)
Base machine with vacuum meters, tractor mounted PTO pump, and Blue Drive	3 SCV	20 gpm (76l/min)	#1 SCV: Planter lift
			#2 SCV: Markers/fold (manual selector valve)
			#3 SCV: Power Pack



Tractor Hydraulic Requirements - 8 Row Planters (Bulk Fill)			
Configuration	Requirements		Description
Base machine with vacuum meters	3 SCV	25 gpm (~95 l/min)	#1 SCV: Planter lift/Bulk Fill fan
			#2 SCV: Markers/fold (manual selector valve)
			#3 SCV: Vacuum fan
Base machine with vacuum meters and Blue Drive	4 SCV	35 gpm (~130 l/min)	#1 SCV: Planter lift\Bulk Fill fan
			#2 SCV: Markers/fold (manual selector valve)
			#3 SCV: Vacuum fan
			#4 SCV: Power Pack
Base machine with vacuum meters and tractor mounted PTO pump	2 SCV	15 gmp (~57 l/min)	#1 SCV: Planter lift/Bulk Fill fan
			#2 SCV: Markers/fold (manual selector valve)
Base machine with vacuum meters, tractor mounted PTO pump, and Blue Drive	3 SCV	25 gpm (~95 l/min)	#1 SCV: Planter lift\Bulk Fill fan
			#2 SCV: Markers/fold (manual selector valve)
			#3 SCV: Power Pack



MINIMAL TRACTOR HORSEPOWER REQUIREMENTS		
Configuration	Requirements	Description
8 Row 70CM, Row Hoppers	100 ¹ HP	Base machine
8 Row 70CM w/ Split Row, Row Hoppers	180 ¹² HP	Base machine
8 Row 70CM, Bulk Fill	120 ¹ HP	Base machine
8 Row 70CM w/ Split Row, Bulk Fill	200 ¹² HP	Base machine
¹ Options, such as Liquid or Dry Fertilizer, as well as planting speed and terrain can increase given requirements significantly.		
² Add 10 HP for Even-Row equipped planters.		

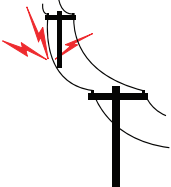

1. Read and understand instructions provided in this manual and warning labels. Review these instructions frequently!
 2. This machine is designed and built with your safety in mind. Do not make any alterations or changes to this machine. Any alteration to design or construction may create safety hazards.
 3. A large portion of farm accidents happen from fatigue or carelessness. Safe and careful operation of tractor and planter will help prevent accidents.
 4. Never allow planter to be operated by anyone unfamiliar with operation of all functions of the unit. Operators must read and thoroughly understand all instructions given in this manual before operating or working on equipment.
 5. Be aware of bystanders, particularly children! Always look around to make sure it is safe to start tow vehicle engine or move planter. This is particularly important with higher noise levels and quiet cabs, as you may not hear people shouting.
 6. Make sure planter weight does not exceed towing capacity of tractor, or bridge and road limits. This is critical to maintain safe control and prevent death or injury, or property and equipment damage.
 7. Never ride or allow others to ride on planter.
 8. Store planter in an area away from human activity. DO NOT permit children to play on or around the stored unit.
 9. Keep hands, feet, and clothing away from moving parts. Do not wear loose-fitting clothing which may catch in moving parts.
 10. Always wear protective clothing, shoes, gloves, hearing, and eye protection applicable for the situation.
 11. Do not allow anyone to stand between tongue or hitch and towing vehicle when backing up to planter.
 13. Prevent electrocution, other injuries, or property and equipment damage. Watch for obstructions such as wires, tree limbs, etc. when operating machine. Be aware of clearances during turns and when folding/unfolding planter.
 14. Reinstall all guards removed for maintenance activities. Never leave guards off during operation.
 15. Use of aftermarket hydraulic, electric, or PTO drives may create serious safety hazards to you and people nearby. If you install such drives, follow all appropriate safety standards and practices to protect you and others near this planter from injury.
 16. Follow all federal, state/provincial, and local regulations when towing farm equipment on a public highway. Use safety chain (not an elastic or nylon/plastic tow strap) to retain connection between towing and towed machines in the event of primary attaching system separation.
 17. Make sure all safety/warning lights, SMV sign, and reflective decals are in place and working properly before transporting the machine on public roads.
 18. Limit towing speed to 24 km/h. Tow only with farm tractor of a minimum 90 HP. Allow for unit length when making turns.
 19. Reduce speed prior to turns to avoid the risk of overturning. Always drive at a safe speed relative to local conditions and ensure your speed is slow enough for a safe emergency stop.
 20. Chemical application is often an integral part of planting. Follow label instructions for proper chemical mixing, handling and container disposal methods.
 21. Be familiar with safety procedures for immediate first aid should you accidentally contact chemical substances.
 22. Use the proper protective clothing and safety equipment when handling chemicals.
 23. Chemicals are supplied with Material Safety Data Sheets (MSDS) that provide full information about the chemical, its effects on exposure, and first aid needs in the event of an emergency. Keep your MSDS file up-to-date and available for first responders in case of emergency.
 24. When servicing ground engaging components such as opening disks and firming points, use special care to avoid points and edges worn sharp during use.
 25. Transporting planter with hoppers over half full or unevenly loaded can cause loss of control and could result in death, serious injury, or damage to property and equipment.
 26. Use professional help if you are unfamiliar with working on hydraulic systems. Pressurized hydraulic fluid can penetrate body tissue and result in death, serious infection, or other injuries.
- Never pour waste onto the ground, down a drain, or into any water source.
- When disposing of waste such as oil, use leakproof containers. Be sure to use containers that do not resemble food or beverage which may mislead someone into consuming them. Dispose of oil per your local, regional requirements.
- When disposing of any fertilizer chemicals used, contact the supplier of the chemicals.
- Model 3505 planter consists of 85% recyclable metals, 10% recyclable plastic and rubber, and 5% waste.

Following are some common hazard warnings associated with this equipment. Pay close attention to all safety, operating, and maintenance information in this manual and decals applied to your equipment.

	<p>Contacting or coming close to power lines or other high energy sources will cause death or serious injury.</p>
	<p>Keep away from power lines or high energy sources at all times.</p>

	<p>Improperly operating or working on this equipment could result in death or serious injury. Read and follow all instructions in Operator Manual before operating or working on this equipment.</p>
	

	<p>Falling equipment can cause death or serious injury. Install all lockup devices or lower planter to ground before working on equipment.</p>
	

	<p>Explosive separation of rim and tire parts can cause death or serious injury. Overinflation, rim and tire servicing, improper use of rims and tires, or worn or improperly maintained tires could result in a tire explosion.</p>
	

SAFETY SIGNS AND DECALS

	<p>All safety/warning lights, reflective decals, and SMV sign must be in place and visible before transporting machine on public roads or death, serious injury, and damage to property and equipment may result. Check federal, state/provincial, and local regulations before transporting equipment on public roads.</p>
---	---



Safety signs and decals are placed on the machine to warn of hazards and provide important operating and maintenance instructions. Information on these signs are for your personal safety and the safety of those around you. FOLLOW ALL SAFETY INSTRUCTIONS!

- Keep signs clean so they can be easily seen. Wash with soap and water or cleaning solution as required.
- Replace safety signs if damaged, painted over, or missing.
- Check reflective decals and SMV sign periodically. Replace if they show any loss of reflective properties.
- When replacing decals, clean machine surface thoroughly with soap and water or cleaning solution to remove all dirt and grease.

NOTE: Safety sign and decal locations are shown in the Parts Manual for this machine.

NOTE: Style and locations of SMV sign, reflective decals, and safety/warning lights conform to ANSI/ASABE S279.14 JUL 2008 and ANSI/ASABE S276.6 JAN 2005.





PICTORIAL DECALS

No.	Decal	Placement	Meaning
101			Oil/Grease daily.
102			Oil/Grease weekly.





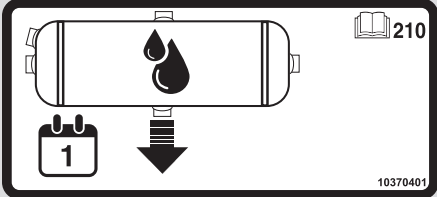

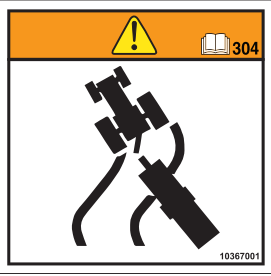

PICTORIAL DECALS

No.	Decal	Placement	Meaning
104		On selector valve.	<p>Turn left to choose the Row Marker hydraulic circuit in order to raise/lower markers.</p> <p>Turn right to choose the Planter Fold hydraulic circuit in order to fold/unfold planter.</p> <p>Make sure there is no pressure in the system.</p>
108		On planter frame.	Turn lever clockwise for planting position; counterclockwise for transport position.
201			Upper sprocket is the drive sprocket. Lower sprocket is the driven sprocket.
202			Rotate knurled collar on wrap spring tightener to release spring tension.
205		On transmission.	Upper sprocket is the drive sprocket. Lower sprocket is the driven sprocket.





PICTORIAL DECALS

No.	Decal	Placement	Meaning
206		On IPN modules.	<p>Ensure that O-Ring(s) are in place on M12 connector(s) (Ethernet).</p> <p>Ensure that M12 connector(s) are torqued to 0.7 Nm.</p>
207		Under modules cover.	DO NOT wash modules directly with cover removed.
210		On PDP tank.	<p>Drain moisture from air tank daily.</p> <p>Drain tank completely for storage.</p>
213		On water tank.	Water for emergency rinse.
302		On insecticide hopper lids.	Agricultural chemicals can cause death or serious injury to persons, animals, and plants or seriously damage soil, equipment, and property. Read and follow all chemical and equipment manufacturer labels and instructions.

PICTORIAL DECALS

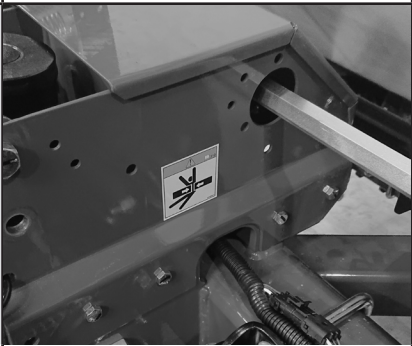

No.	Decal	Placement	Meaning
304		<p>On planter frame.</p>	<p>Loss of control can cause death or serious injury, or damage to property and equipment. Tow only with farm tractor weight rated and configured for this equipment. Use safety chains and transport as specified in the Operator's and Parts Manuals.</p>
306			<p>Uncontrolled machine movement can crush resulting in death, serious injury, or damage to property and equipment.</p> <p>Install safety lockup devices before working under or transporting this equipment.</p>
307			<p>Removing this wheel and axle assembly can cause equipment to tip over, which could result in death, serious injury, or damage to property and equipment.</p>
308			<p>Improperly operating or working on this equipment could result in death or serious injury. Read and follow all instructions in Operator Manual before operating or working on this equipment.</p>
309		<p>On row markers.</p>	<p>Row marker can lower at any time and could cause death or serious injury.</p> <p>Stay away from row markers!</p> <p>Install safety lockup device when not in use.</p>



PICTORIAL DECALS



No.	Decal	Placement	Meaning
310			<p>Uncontrolled movement of planter components can cause death, serious injury, or damage to property and equipment.</p> <p>Raise planter and install cylinder lockups before folding. Fold on level ground. Install wing safety latches before towing.</p>
401		<p>On vacuum fan.</p>	<p>Fan can start at any time. Operating fan can blow debris and has a high noise level.</p> <p>Always wear eye and hearing protection when working around fan.</p>
402			<p>Improper lifting of row unit can cause serious injury. An empty row unit requires minimum 40.8 kg lift. Set down pressure springs to minimum, lower planter to ground, and empty seed hopper before attempting to lift with this lever.</p>

INITIAL PREPARATION

Following information is general in nature to aid in preparation of tractor and planter for use, and to provide general operating procedures. Operator experience, familiarity with the machine, and the following information should combine for efficient planter operation and good working habits.

 WARNING	<p>Improperly operating or working on this equipment could result in death or serious injury. Read and follow all instructions in Operator Manual before operating or working on this equipment.</p>
	

 WARNING	<p>Loose transport wheel lug bolts can result in wheel separation from planter and cause death, serious injury, and damage to property and equipment. Torque transport wheel $\frac{9}{16}$"- 18 lug bolts to 180 ft-lb (~244 Nm) before operating planter for the first time and periodically after.</p>
	

 WARNING	<p>Explosive separation of rim and tire parts can cause death or serious injury. Overinflation, rim and tire servicing, improper use of rims and tires, or worn or improperly maintained tires could result in a tire explosion.</p>
	

TIRES PREPARATION

1. Torque transport wheel $\frac{9}{16}$ "- 18 lug bolts to 90 ft-lb (~122 Nm).
2. Inflate transport/ground drive tires to 40 PSI (2,76 bar).
3. Inflate contact drive tires to 50 PSI (3,45 bar).



TRACTOR REQUIREMENTS

NOTICE

All Hydraulic Requirements: Minimum Pressure 2350 PSI (~16203 kPa); Maximum Pressure 3000 PSI (~20684 kPa). Check tractor hydraulics to ensure that maximum pressure cannot be exceeded.

Consult your dealer for information on horsepower requirements and tractor compatibility. Requirements vary with planter options, tillage, and terrain.

A 12 VDC electrical system is required to operate planter safety/warning lights, digital vacuum gauge, and optional pneumatic down pressure system or work lights.

Two dual remote hydraulic outlets (SCV) are required on all models. An additional SCV and zero pressure case drain, or PTO pump is required for vacuum and bulk fill equipped planters.

Hydraulic maximum flow rate is required to operate vacuum fan motor:
8 Row = 5 GPM @ 2350 PSI (~19 l/min@16203 kPa)



WARNING



Uncontrolled movement of equipment can cause loss of control and could result in death, serious injury, or damage to property and equipment. Install all safety pins before transporting equipment.

ROW MARKER SAFETY LOCKUP

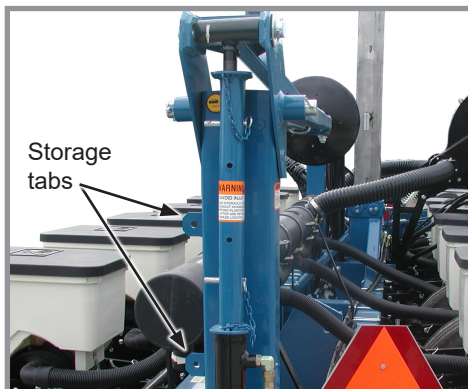

Row marker lockup installed



Row marker lockup in storage location

Install row marker safety lockup devices over marker cylinder rods whenever markers are not being used. Keep in storage position on front side of row marker arms when removed. Secure in either location with attached clevis pins.

SAFETY LOCKUP PIN

Safety lockup pin is inserted through the center post and kept in place by a hairpin clip.

For planters with bulk fill, safety lockup pin is stored on pin holder on front latch post.

Pin must be installed under planter frame during transport or when working on equipment when raised.

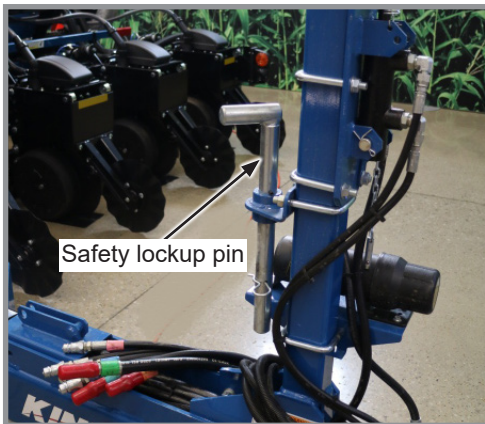

Bulk Fill

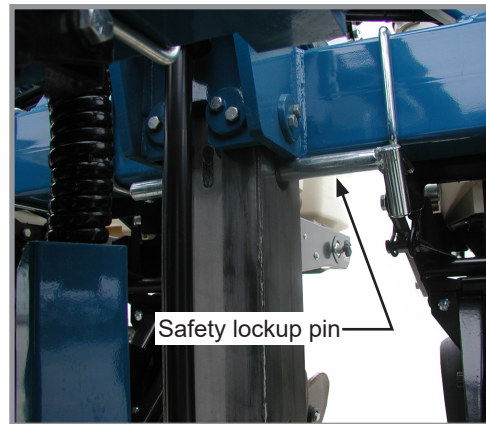

Conventional

STROKE LIMITER PIN (CONVENTIONAL ONLY)

Pin must be installed above planter frame during normal operation to contact stroke limiter valve and prevent lift cylinder from overextending. Refer to Hydraulic Operation in this section.



TRANSPORT LATCH LOCKING PIN

Spring loaded transport latch on planter hitch locks in place under toolbar when planter is rotated to transport position.

Always install transport latch locking pin to lock transport latch before transporting planter.

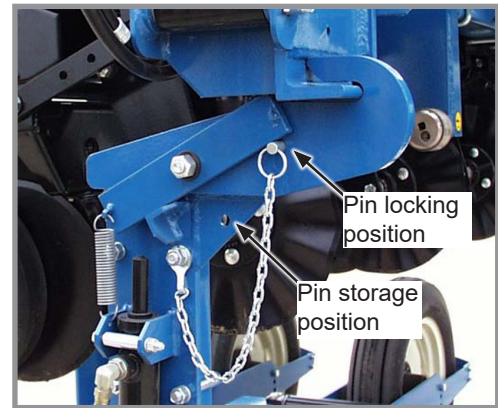

Transport latch locking pin locations

HITCH LENGTH ADJUSTMENT

The hitch consists of a telescoping outer and inner section. Hitch length can be adjusted to three locations to accommodate tractor tire options and attachments installed on planter.

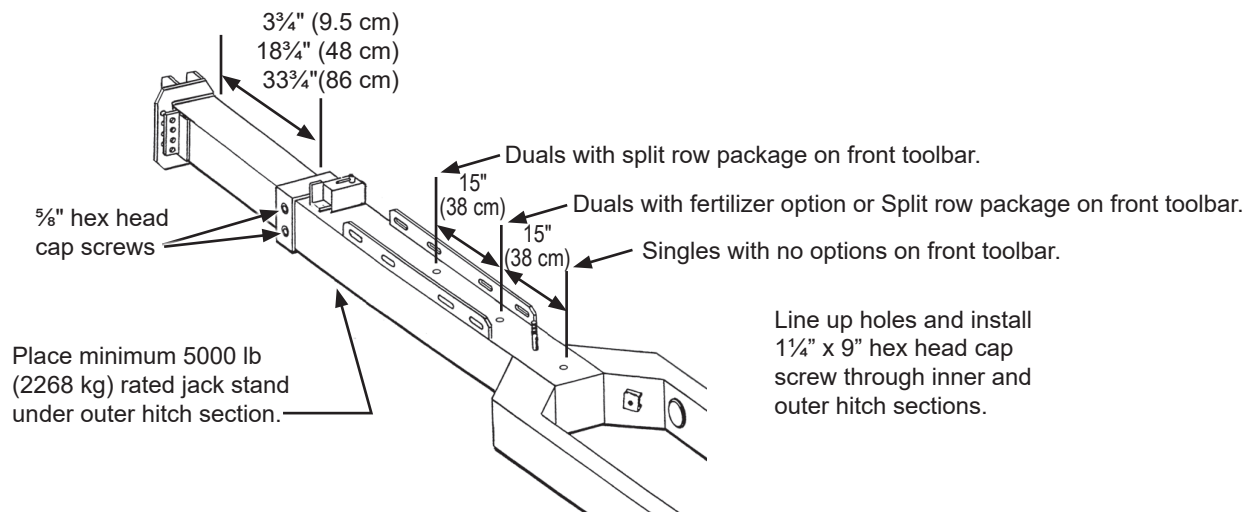

1. Lower machine to field position and block transport wheels.
2. Support outer hitch section with a minimum 5000 lb (2268 kg) rated jack stand to take weight off inner section.

NOTE: Remove and reinstall hitch mounted brackets as needed to access hitch adjustment holes.

3. Remove 1 1/4" x 9" hex head cap screw, lock washer, and hex nut from hitch. Loosen two 5/8" hex head cap screws on front L.H. side of outer hitch section.

NOTICE

DO NOT set hitch length so turning is limited when machine is in road transport position or equipment may be damaged.

4. Reposition inner hitch section so hole lines up with hole in outer hitch section at desired length. Install 1 1/4" x 9" hex head cap screw, lock washer, and hex nut. Torque to 840 ft-lb (1138 N-m).
5. Torque two 5/8" hex head cap screws to 110 ft-lb (149 N-m).

JACK STAND

NOTICE Install jack stand in stowed position during transport and field operation to prevent equipment damage.

An easily removable jack stand is provided to aid in connecting and disconnecting planter from tractor.

Slide notched end of jack stand over mount round bar at parking/lift or stowed position.

Install pin through mount and jack stand. Secure with lynch pin.

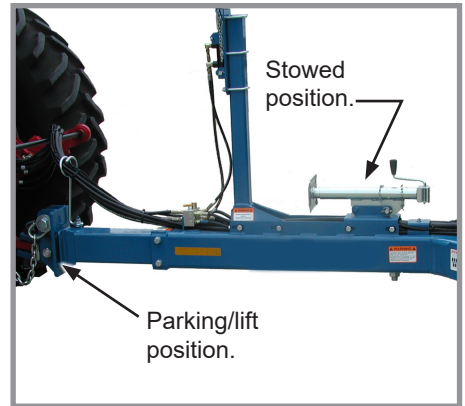

Jack stand locations

HYDRAULIC OPERATION - CONVENTIONAL

NOTE: PTO pump drive and oil cooler package is available from Kinze through your Kinze Dealer to increase your tractor's operating capabilities.

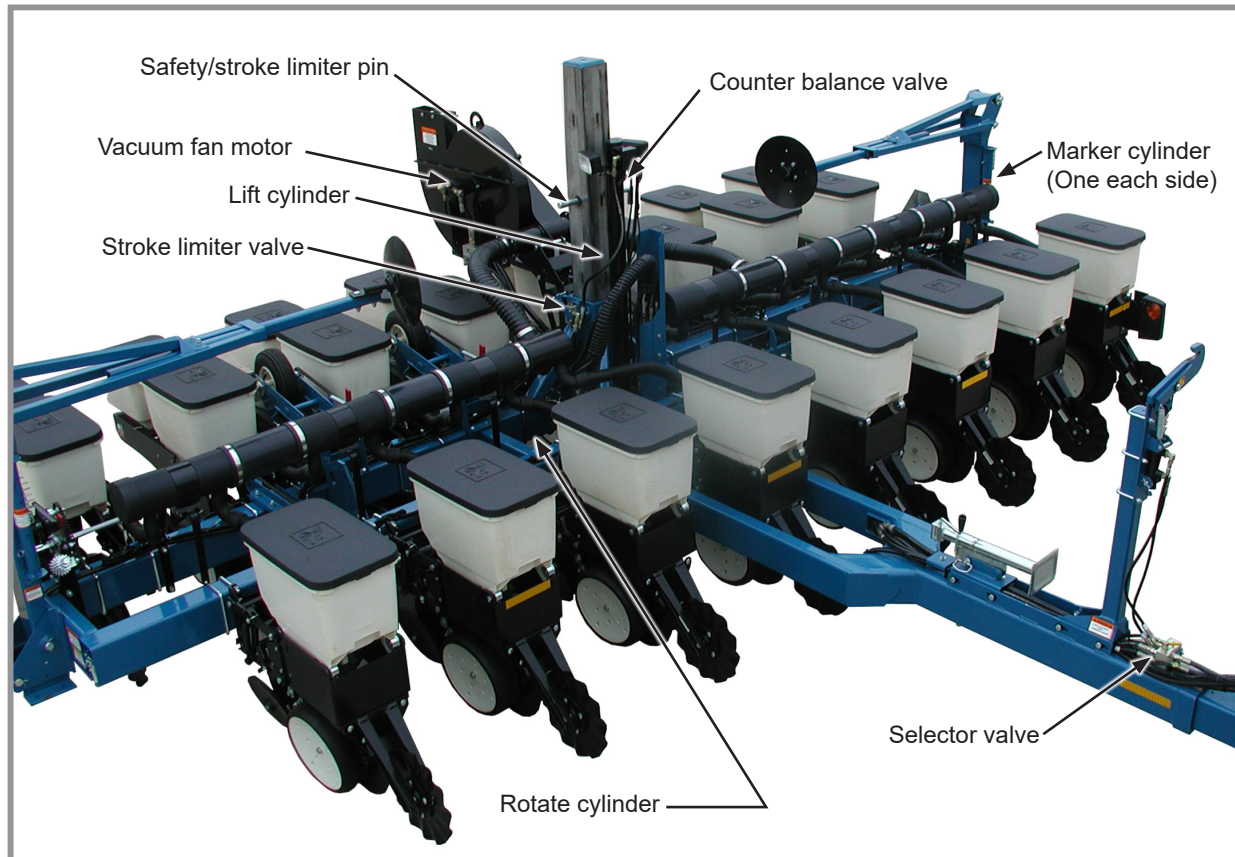

3505 hydraulic system (schematic located in Lubrication and Maintenance section)

HYDRAULIC OPERATION - CONVENTIONAL (CONTINUED)

PLANTER LIFT SYSTEM

Planter lift system consists of one lift cylinder located at center of machine. Cylinder mounts are located front and rear side of center post. Install cylinder in rear position for planters with rear mounted row units only. Cylinder must be installed in front position for planters with front mounted options (push row units, fertilizer, etc.). A stroke limiter valve shuts off hydraulic flow when the planter lifts to raised field position and contacts safety/stroke limiter pin. A counter balance valve holds planter in position until reverse pressure is applied.

NOTE: Planter lift cylinder is equipped with a counter balance valve. Hydraulic pressure is required to lower planter

SELECTOR VALVE, ROTATE AND MARKER CYLINDERS

A hitch mounted, hand operated selector valve selects row marker or fold functions. Rotate cylinder is mounted on the frame and rotates planter to/from transport position. Row marker cylinders raise and lower row markers.

NOTE: Hydraulic pressure will prevent valve from moving. Release hydraulic pressure from system before attempting to move selector valve handle.

VACUUM FAN MOTOR AND VALVE BLOCK ASSEMBLY (If equipped)

Hydraulically operated motor requires maximum flow rate of 5 GPM @ 2000 PSI (~19 l/min @16202 kPa) to operate properly. It must be connected to a zero pressure case drain and connected to the correct pressure and return SCV's or PTO fittings.

A pressure relief valve in the valve block assembly prevents build up of oil pressure over 35 PSI in case drain line when vacuum fan motor is in operation. This valve vents oil outside of valve block through a drain hole in the aluminum valve block. This can occur whenever the case drain is improperly connected or motor circuit pressure is too high.

["Hydraulic Diagram - Vacuum Fan Motor System" on page 6-41.](#)

The valve block also contains a check valve that prevents vacuum fan from operating in wrong direction if pressure is applied to of motor return side and allows fan to coast to a stop when tractor hydraulic control is returned to neutral.

NOTE: Fan turns at a reduced speed if reverse pressure is applied.

HYDRAULIC OPERATION - CONVENTIONAL (CONTINUED)

RAISED FIELD POSITION

Row units raise approximately 14 inches (~36 cm) and toolbar approximately 40 inches (~102 cm) off ground. This position is used in making turns or passing over waterways during field operation.

Install safety/stroke limiter pin above frame assembly to make contact with stroke limiter valve. Secure with hairpin clip.

RAISED TRANSPORT POSITION

Planter raises high enough to permit row units to clear transport wheels as planter is rotated.

1. Remove hairpin clip and safety lockup pin.
2. Raise planter until lift cylinder is fully extended.
3. Reinstall safety lockup pin and hairpin clip in same hole which is now below frame assembly.
4. Lower planter onto safety lockup pin.

HYDRAULIC OPERATION - BULK FILL

NOTE: PTO pump drive and oil cooler package is available from Kinze through your Kinze Dealer to increase your tractor's operating capabilities.

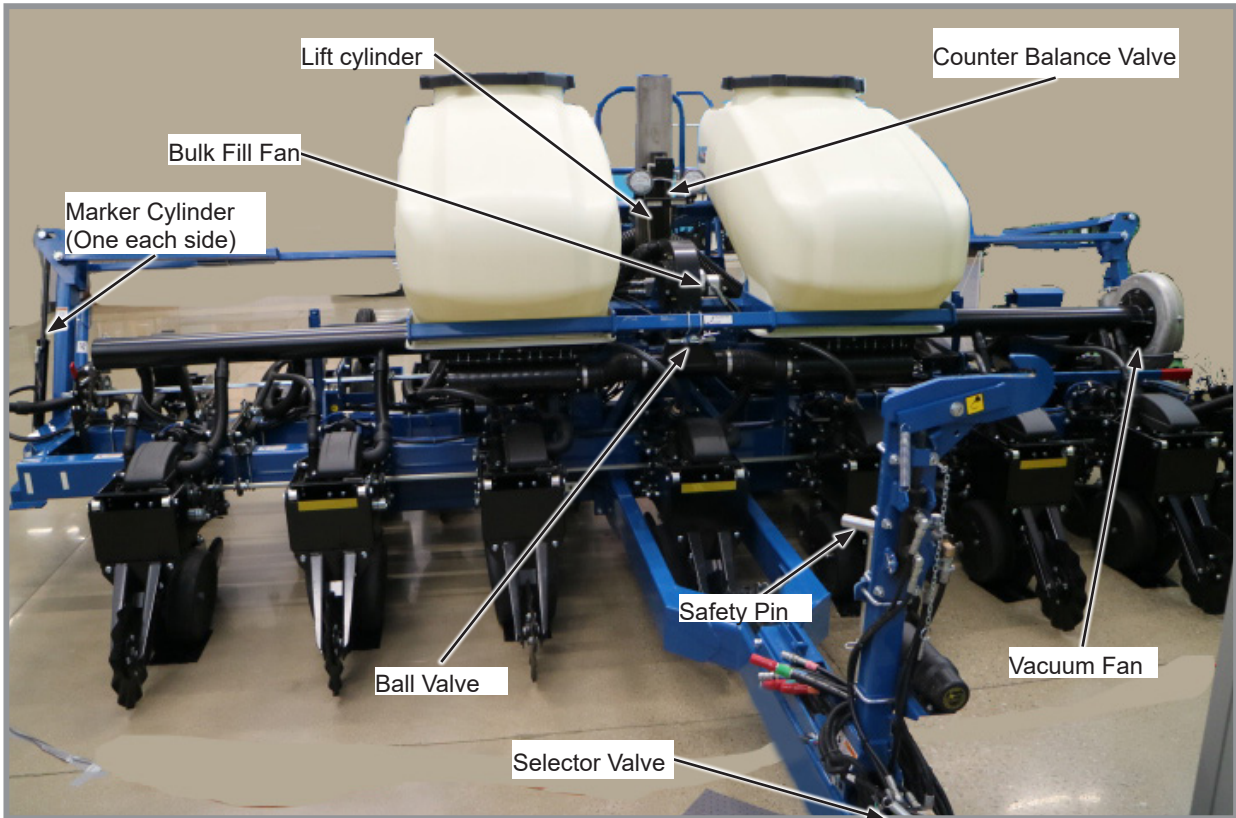

3505 hydraulic system (schematic located in Lubrication and Maintenance section)

HYDRAULIC OPERATION - BULK FILL (CONTINUED)

PLANTER LIFT SYSTEM

Planter lift system consists of one lift cylinder located at center of machine. A counterbalance valve holds planter in position until reverse pressure is applied. A lift limiter valve closes when the bearing contacts the hole for the safety pin at field turn height. A ball valve located on the front of the bulk fill mount is opened to bypass the lift limiter and allow full lift for transport.

NOTE: Planter lift cylinder is equipped with a counter balance valve. Hydraulic pressure is required to lower planter

SELECTOR VALVE, ROTATE AND MARKER CYLINDERS

A hitch mounted, hand operated selector valve selects row marker or fold functions. Rotate cylinder is mounted on the frame and rotates planter to/from transport position. Row marker cylinders raise and lower row markers.

NOTE: Hydraulic pressure will prevent valve from moving. Release hydraulic pressure from system before attempting to move selector valve handle.

VACUUM FAN AND BULK FILL MOTOR AND VALVE BLOCK ASSEMBLY (If equipped)

Hydraulically operated motor requires maximum flow rate of 5 GPM @ 2350 PSI (19 LPM @ 16202 kPa) to operate properly. It must be connected to a zero pressure case drain and connected to the correct pressure and return SCV's or PTO fittings.

See [“Hydraulic Diagram - Vacuum Fan Motor System” on page 6-41](#) in Lubrication and Maintenance section.

The valve block also contains a check valve that prevents vacuum fan from operating in wrong direction if pressure is applied to of motor return side and allows fan to coast to a stop when tractor hydraulic control is returned to neutral.

Bulkfill air pressure is controlled by a mechanical flow control valve located on the transport catch post on hitch of planter. Hydraulic pressure from the lift circuit operates the fan when the planter is lowered and SCV is left in detent. When the planter is lifted, the fan will shut off until the unit is again lowered.

NOTE: Fan turns at a reduced speed if reverse pressure is applied.

RAISED FIELD POSITION

Row units raise approximately 14 inches (35.5 cm) and toolbar approximately 40 inches (101.6 cm) off ground. This position is used in making turns or passing over waterways during field operation.

Close ball valve to limit lift height for field operation.

RAISED TRANSPORT POSITION

Planter raises high enough to permit row units to clear transport wheels as planter is rotated.

1. Open ball valve.
2. Raise planter until lift cylinder is fully extended.
3. Install safety lockup pin and hairpin clip in same hole which is now below frame assembly.
4. Lower planter onto safety lockup pin.

OIL SPECIFICATION

Hydraulic transmission oil is used in the planter and PTO. The oil chemical properties:

Viscosity, mm ² /s @ 100 °C. ASTM D-445	10
Viscosity, mm ² /s @ 40 °C. ASTM D-445	63
Viscosity Index ASTM D-2270	143
TBN, mg KOH/g ASTM D-2896	9
TAN, mg KOH/g (ASTM D-664)	2
Pour Point, °C ASTM D-5950	-42
Specific Gravity @ 15.6°C. ASTM D-4052	0,876
Flash Point, COC, °C. ASTM D-92	220

NOTE: Factory filled with VALVOLINE™ UNITRAC SAE 80W.

PTO PUMP DRIVE AND OIL COOLER OPTION

The PTO pump drive and oil cooler option is for tractors with less than required hydraulic output needed to operate hydraulic-driven vacuum fan and other planter hydraulic requirements.

A 1000 RPM PTO is required to operate the PTO-driven hydraulic pump.

PTO pump option fits to a 1 $\frac{5}{8}$ "-21 or 1 $\frac{3}{4}$ "-20 spline with mount option from Ag Power Systems (www.agpowersystems.com), 13.5 GPM 2000 PSI pump (~49 l/min @13790 kPa), 10 gallon (~38 l) capacity hydraulic reservoir, 15 GPM 2000 PSI (~57 l/min @13790 kPa)-rated oil cooler, spin-on 10-micron oil filter, and required hydraulic valves and fittings.

PTO PUMP DRIVE AND OIL COOLER OPTION (CONTINUED)

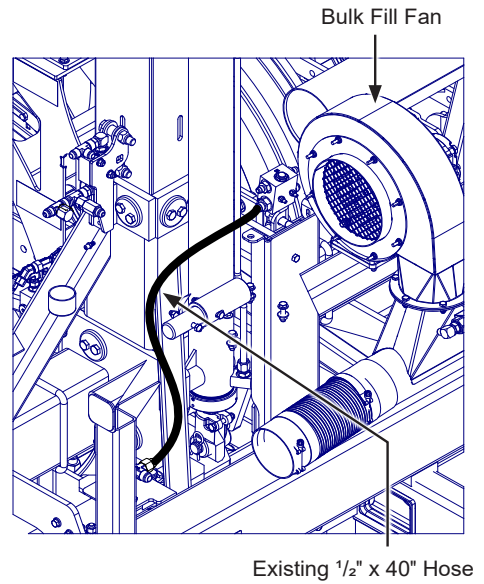
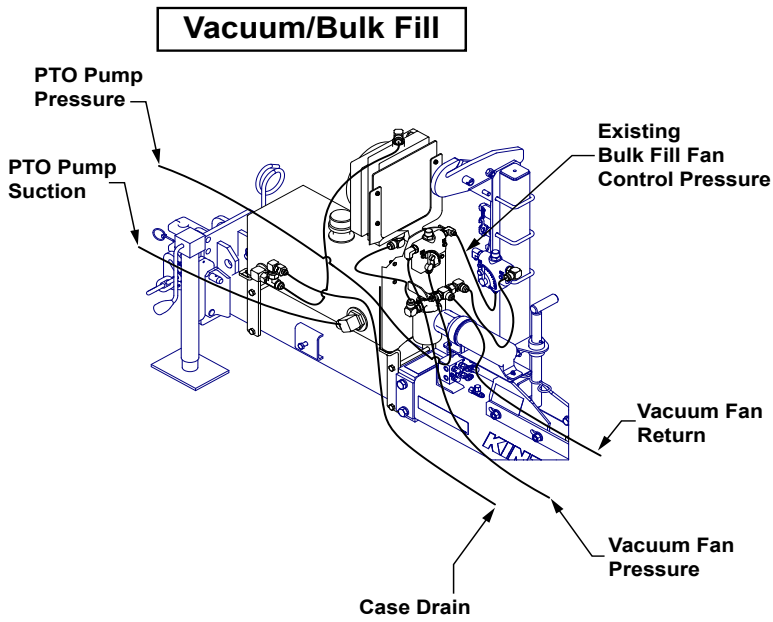

Vacuum/Conventional

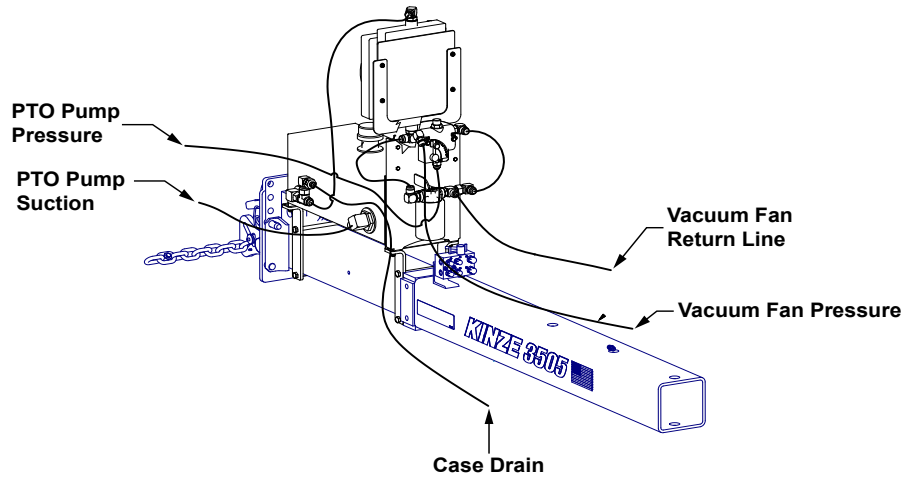

BLUE DRIVE BLUE VANTAGE PTO PUMP DRIVE AND OIL COOLER OPTION

Vacuum/Conventional

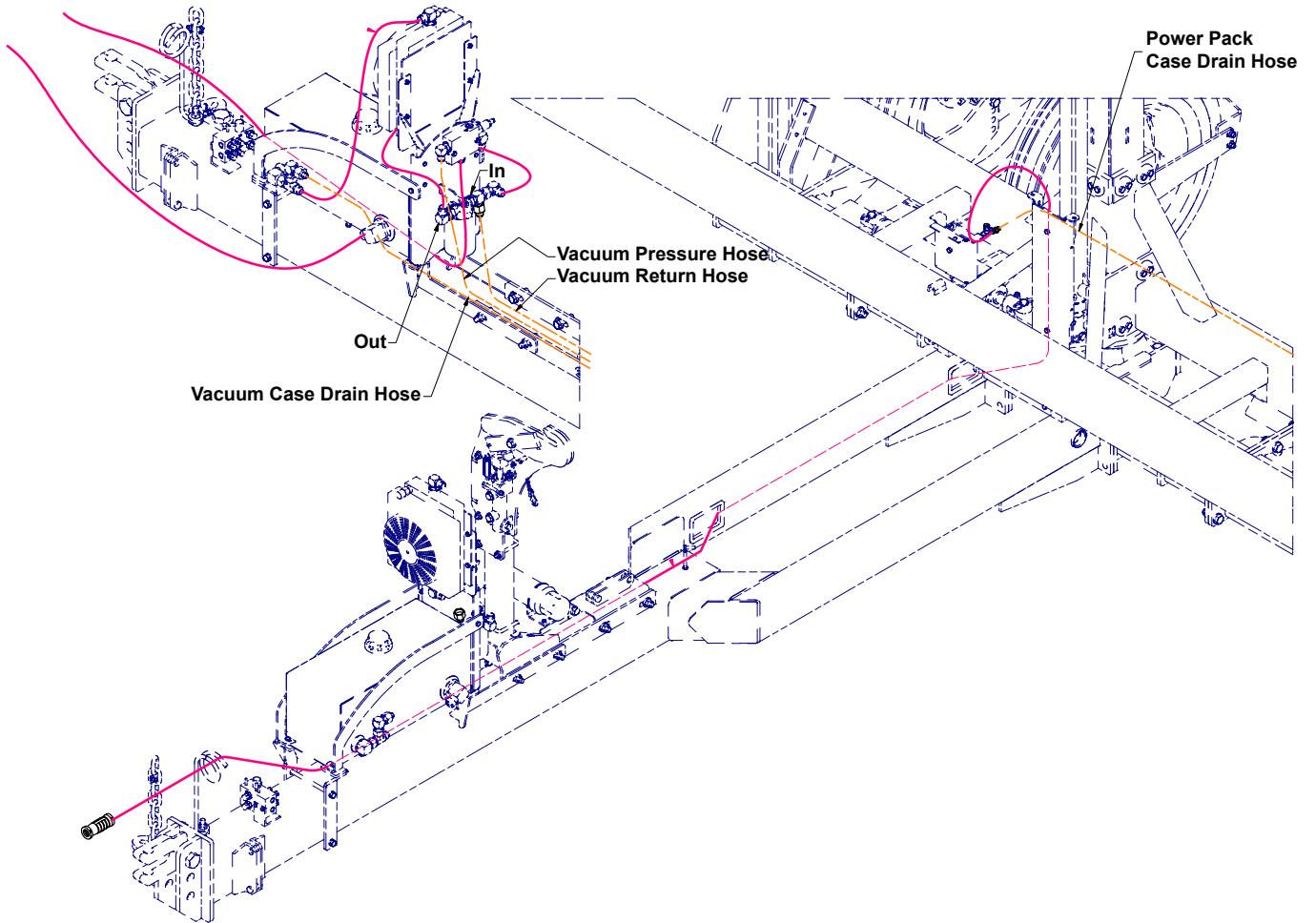

**BLUE DRIVE BLUE VANTAGE PTO PUMP DRIVE AND OIL COOLER OPTION
(CONTINUED)**

Vacuum/Bulk Fill

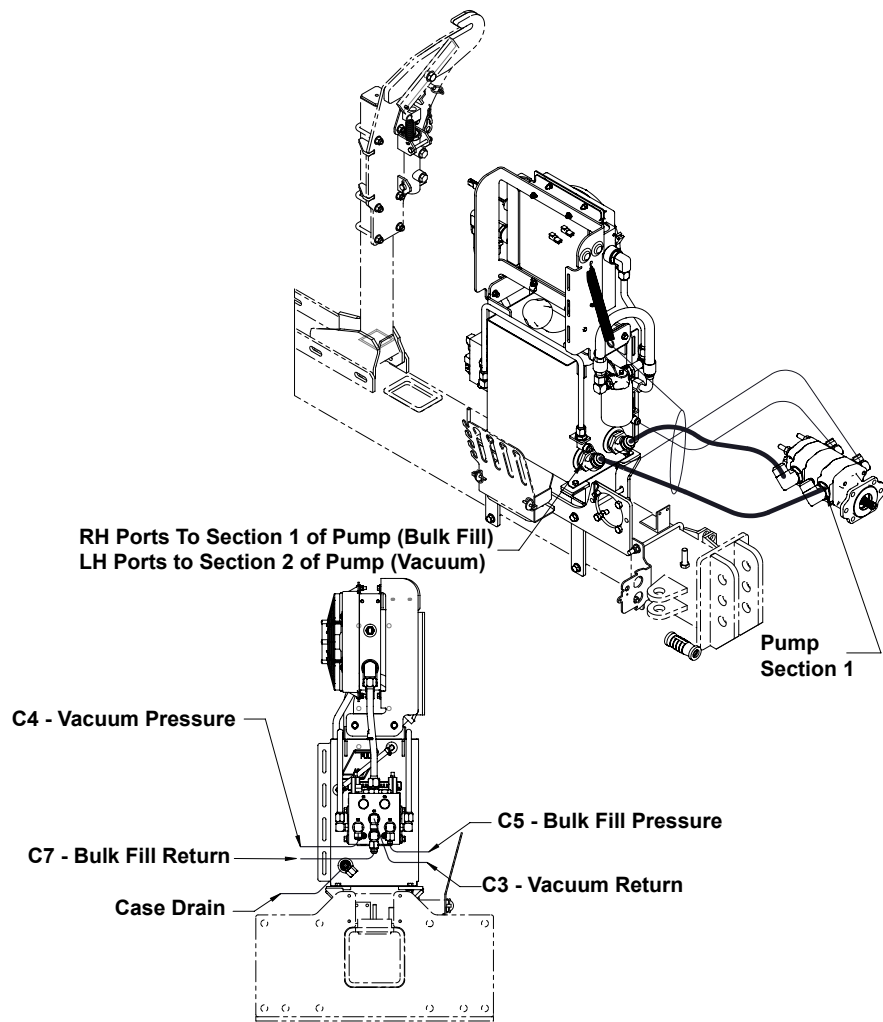

TRACTOR PREPARATION AND HOOKUP

NOTE: A 2-Point Hitch option is available for use with Category 3N or 3 three-point hitch designs to convert planter from drawn to semi-mounted. Safety chain is not used with 2-point hitch.

1. Adjust tractor drawbar 13 to 17 inches (33 - 43 cm) above ground. Adjust drawbar so hitch pin hole is directly below center line of PTO shaft. Make sure drawbar is in a stationary position.
2. Back tractor to planter and connect with a minimum $\frac{3}{4}$ " diameter hitch pin. Secure with a locking or cotter pin.



Drawbar and safety chain connection

NOTE: DO NOT install safety chain using clevis mounting hardware. Safety chain MUST be installed separately.

3. Safety chain must be used to keep planter and tractor connected in case of a hitch pin/drawbar failure. Attach safety chain at an unused clevis mounting hole on the planter hitch. Torque hardware to 840 ft-lb (1138.8 N-m).

WARNING

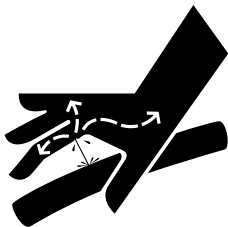

Pressurized hydraulic fluid can penetrate body tissue and result in death, serious infection, or other injuries. Fluid injected under skin must be **IMMEDIATELY** removed by a surgeon familiar with this type of injury. Make sure connections are tight and hoses and fittings are not damaged before applying system pressure. Leaks can be invisible. Keep away from suspected leaks. Relieve pressure before searching for leaks or performing any system maintenance.

NOTICE

Wipe hose ends to remove any dirt before connecting couplers to tractor ports or contamination may cause equipment failure.

4. Connect hydraulic hoses to tractor ports in a sequence familiar and comfortable to the operator.

NOTICE	Vacuum and bulk fill fan motor hydraulic hoses and case drain must be installed correctly. Motor can be damaged or equipment will not operate properly.
---------------	--

NOTICE	Proper routing of hydraulic hoses from planter to tractor is crucial. If done improperly, hoses can get pinched, cut or broken when planter is in operation.
---------------	---

NOTE: If tractor is equipped with an adjustable flow outlet (SCV), set to full flow position. For tractors not equipped with a method for finite adjustment of hydraulic flow, Flow Control Needle Valve Kit G1K426 is available from Kinze Repair Parts through your Kinze Dealer.



G1K426 needle valve kit

Function	Hose Color	Pressure	Return
Lift/Bulk Fill	Red	A	B
Fold/Marker	Blue	A	B
Vacuum	Green	A	B
Case Drain	Orange/Green	---	CD

5. If equipped with ISOBUS system, attach ISO connector.
6. For planters not equipped with ISOBUS, connect ASABE Standards 7 terminal connector for safety/warning lights on planter to ASABE Standards receptacle on tractor. If your tractor is not equipped with an ASABE Standards receptacle, check with your tractor manufacturer for availability. Check warning lights on planter work in conjunction with warning lights on tractor.

NOTE: A 12 VDC battery connection is required to power the vacuum fan digital gauge. Connect “red” wire to positive (+) battery terminal and “black” wire to negative (-) battery terminal.

7. Completely raise parking stands, located behind drawbar hitch, to prevent damage to stands and equipment when moving planter.
8. (If applicable) Connect compressor harness.
9. If equipped with Blue Drive, attach the Blue Drive 6 pin connector and Ethernet cable to the Blue Vantage display.
10. Raise jack stand and remount horizontally on storage bracket.

LEVEL PLANTER

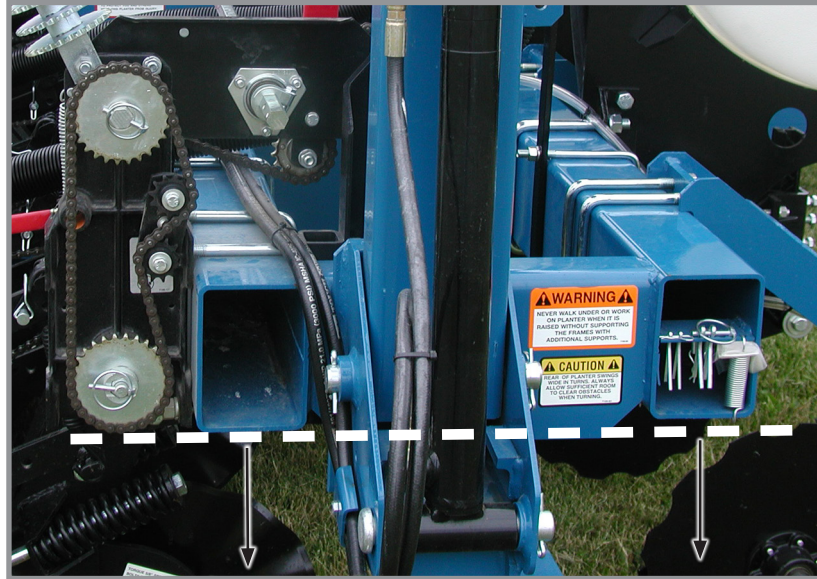

Bottom of toolbars 20" - 22" (~51- 56 cm) from planting surface

Lateral adjustment is maintained by tire pressure. Check tires are inflated to specification.

Front and rear level adjustment is maintained by hitch clevis position unless tractor drawbar is adjustable for height. Planter frame and row unit parallel arms must be level for proper planter and row unit operation. Bottom of toolbar should be 20" to 22" (~51- 56 cm) from planting surface.

1. Lower planter to planting position and check planter is level front to rear. Go to step 2 if hitch is too high or low.

NOTE: DO NOT install safety chain using clevis hardware. Move safety chain location if necessary.

2. Remove clevis hitch hex head cap screw and lock nut using a torque wrench. Replace if off-torque is below 75 ft-lb (~102 Nm) or there is corrosion or damage.

NOTE: Clevis must be free to move on hitch. DO NOT OVERTIGHTEN hardware.

3. Align clevis to hitch holes at new location and install hex head cap screw and lock nut. Tighten lock nut until threads are fully engaged and hex head cap screw and lock nut are firmly against hitch bracket.
4. Recheck with planter in field.

CYLINDER INFORMATION

Description	Row Marker Cylinder	Transport Latch Cylinder	Lift Cylinder (Bulk Fill)	Rotation Cylinder
Intended Use	Double Acting Applications	Double acting applications	Double Acting Applications	Double Acting Applications
Piston	Ductile Iron	Ductile iron	Ductile Iron	Ductile Iron
Gland	Ductile Iron	Ductile iron	Ductile Iron	Ductile Iron
Tube	ST 52 DOM Tubing	Cast	ST 52 DOM Tubing	ST 52 DOM Tubing
Rod	1045 Nitro Rod	1045 Nitro rod	1045 Nitro Rod	1045 Nitro Rod
End Mounts	U-Brackets	None	Trunnion	Tang
Tube Seal	Buna O-Ring with Polytemp Back-up	O-Ring with polytemp back-up	Buna O-Ring with Polytemp Back-up	Buna O-Ring with Polytemp Back-up
Rod Seal	Polyester Alloy U-cup	Polyester alloy u-cup	Polyester Alloy U-cup	Polyester Alloy U-cup
Rod Wiper	Polyester Alloy Snap In	Polyester alloy snap in	Polyester Alloy Snap In	Polyester Alloy Snap In
Piston Seal	T-Seal HNBR	T-Seal HNBR	PTFE Seal	T-Seal HNBR
Product Category	Hydraulic Cylinder	Hydraulic Cylinder	Hydraulic Cylinder	Hydraulic Cylinder
Maximum Stroke	8" (~20,32 cm)	2.5" (~6,35 cm)	48" (~121,90 cm)	16" (~40,60 cm)
Working Pressure	2350-3000 PSI (~16203-20684 KPa)	3000 PSI (~20684 kPa)	3000 PSI (~20684 kPa)	3000 PSI (~20684 kPa)
Bore Size	2" (~5,08 cm)	1.5" (~3,81 cm)	3.25" (~8,25 cm)	3" (~7,60 cm)
Shaft Diameter	1" (~2,54 cm)	.750" (~1,91 cm)	1.5" (~3,81 cm)	1.25" (~3,10 cm)
Cylinder Configuration	Simple	Simple	Simple	Simple
Cylinder Action	Double	Double	Double	Double
Material	Steel, Ductile Iron	Steel, Ductile Iron, Cast	Steel, Ductile Iron	Steel, Ductile Iron
Mounting Method	U-Bracket	None	Trunnion	Tang
Mount Location	End Cap	End Cap	Barrel	End Cap
Cylinder Style	Welded	Machined	Welded	Welded

HYDRAULIC HOSE INFORMATION

Part Number	A1078	A1153	A1090	A1121	A11447	A1154
Description	Hose Assembly, 3/8" x 174" (~441,96 cm)	Hose Assembly, 1/4" x 56" (~142,24 cm)	Hose Assembly, 3/8" x 162" (~411,48 cm)	Hose Assembly, 1/4" x 180" (~457,20 cm)	Hose Assembly, 5/8" x 45" (~114,30 cm)	Hose Assembly, 1/4" x 72" (~182,88 cm)
Product Category	Hydraulic Hose	Hydraulic Hose	Hydraulic Hose	Hydraulic Hose	Hydraulic Hose	Hydraulic Hose
Product Form	Hose:Assembly	Hose:Assembly	Hose:Assembly	Hose:Assembly	Hose:Assembly	Hose; Assembly
I.D.	3/8" (~9,53 mm)	1/4" (~6,35 mm)	3/8" (~9,53 mm)	1/4" (~6,35 mm)	5/8" (~15,88 mm)	1/4" (~6,35 mm)
O.D.	.69" (~17,46 mm)	.53" (~13,49 mm)	.69" (~17,46 mm)	.53" (~13,49 mm)	.94" (~23,81 mm)	.53" (~13,49 mm)
Minimum Bend Radius	2 1/2" (~63,50 mm)	4" (~100,60 mm)	2 1/2" (~63,50 mm)	2" (~50,80 mm)	4" (~101,60 mm)	4" (~101,60 mm)
Working Pressure	3000 PSI (~20685 kPa)	3275 PSI (~22580 kPa)	3000 PSI (~20684 kPa)	3250 PSI (~22408 kPa)	2750 PSI (~18961 kPa)	3275 PSI (~22580 kPa)
Temperature Range	-40°F - +212°F (-40°C - +100°C)	-40°F - +212°F (-40°C - +100°C)	-40°F - +212°F (-40°C - +100°C)	-40°F - +212°F (-40°C - +100°C)	-40°F - +212°F (-40°C - +100°C)	-40°F - +212°F (-40°C - +100°C)
Material	Modified Nitrile Type C2	Modified Nitrile Type C2	Modified Nitrile Type C2	Modified Nitrile Type C2	Modified Nitrile Type C2	Modified Nitrile Type C2
Specialized Construction	High tensile steel wire	High tensile steel wire	High tensile steel wire	High tensile steel wire	High tensile steel wire	High tensile steel wire
Media	Hydraulic Fluid	Hydraulic Fluid	Hydraulic Fluid	Hydraulic Fluid	Hydraulic Fluid	Hydraulic Fluid
Application	Agricultural; Construction	Agricultural; Construction	Agricultural; Construction	Agricultural; Construction	Agricultural; Construction	Agricultural; Construction
Part Number	A12080	A12767	A1434	A1155	A15000	A8213
Description	Hose Assembly, 3/8" x 272" (~690,88 cm)	Hose Assembly, 1/2" x 22" (~55,88 cm)	Hose Assembly, 1/2" x 42.5" (~107,95 cm)	Hose Assembly, 1/4" x 48" (~121,92 cm)	Hose Assembly, 3/8" x 174" (~441,96 cm)	Hose Assembly, 1/2" x 29" (~73,66 cm)
Product Category	Hydraulic Hose	Hydraulic Hose	Hydraulic Hose	Hydraulic Hose	Hydraulic Hose	Hydraulic Hose
Product Form	Hose:Assembly	Hose:Assembly	Hose:Assembly	Hose:Assembly	Hose:Assembly	Hose; Assembly
I.D.	3/8" (~9,53 mm)	1/2" (~12,70 mm)	1/2" (~12,70 mm)	1/4" (~6,35 mm)	3/8" (~9,53 mm)	1/2" (~12,70 mm)
O.D.	.69" (~17,46 mm)	.81" (~20,64 mm)	.81" (~20,64 mm)	.53" (~13,49 mm)	.69" (~17,46 mm)	.81" (~20,64 mm)
Minimum Bend Radius	2 1/2" (~63,5 mm)	3 1/2" (~88,90 mm)	3 1/2" (~88,90 mm)	4" (~100,60 mm)	2 1/2" (~63,50 mm)	3 1/2" (~88,90 mm)
Working Pressure	3000 PSI (~20684 kPa)	3000 PSI (~20684 kPa)	3000 PSI (~20684 kPa)	3275 PSI (~22580 kPa)	3000 PSI (~20684 kPa)	3000 PSI (~20684 kPa)
Temperature Range	-40°F - +212°F (-40°C - +100°C)	-40°F - +212°F (-40°C - +100°C)	-40°F - +212°F (-40°C - +100°C)	-40°F - +212°F (-40°C - +100°C)	-40°F - +212°F (-40°C - +100°C)	-40°F - +212°F (-40°C - +100°C)
Material	Modified Nitrile Type C2	Modified Nitrile Type C2	Modified Nitrile Type C2	Modified Nitrile Type C2	Modified Nitrile Type C2	Modified Nitrile Type C2
Specialized Construction	High tensile steel wire	High tensile steel wire	High tensile steel wire	High tensile steel wire	High tensile steel wire	High tensile steel wire
Media	Hydraulic Fluid	Hydraulic Fluid	Hydraulic Fluid	Hydraulic Fluid	Hydraulic Fluid	Hydraulic Fluid
Application	Agricultural; Con- struction	Agricultural; Con- struction	Agricultural; Con- struction	Agricultural; Construction	Agricultural; Construction	Agricultural; Construction

HYDRAULIC HOSE INFORMATION (CONTINUED)

Part Number	A6201	A15064	A1018	A15076-140	A15077-260
Description	Hose Assembly, 1" x 72" (~182,88 cm)	Hose Assembly, 3/8" x 66" (~167,64 cm)	Hose Assembly, 3/8" x 40" (~101,60 cm)	Hose Assembly, 3/8" x 140" (~355,60 cm)	Hose Assembly, 3/8" x 260" (~660,40 cm)
Product Category	Hydraulic Hose	Hydraulic Hose	Hydraulic Hose	Hydraulic Hose	Hydraulic Hose
Product Form	Hose; Assembly	Hose; Assembly	Hose; Assembly	Hose; Assembly	Hose; Assembly
I.D.	1" (~25,4 mm)	3/8" (~9,53 mm)	3/8" (~9,53 mm)	3/8" (~9,53 mm)	3/8" (~9,53 mm)
O.D.	1.5" (38,10 mm)	.69" (17,46 mm)	.69" (17,46 mm)	.62" (15,75 mm)	.62" (15,75 mm)
Minimum Bend Radius	4 3/4" (~120,65 mm)	2 1/2" (~63,50 mm)	2 1/2" (~63,50 mm)	2 1/2" (~63,50 mm)	2 1/2" (~63,50 mm)
Working Pressure	1000 PSI (~6895 kPa)	3000 PSI (~20684 kPa)	3000 PSI (~20684 kPa)	3000 PSI (~22407 kPa)	3000 PSI (~22407 kPa)
Temperature Range	-40°F - +212°F (-40°C - +100°C)	-40°F - +212°F (-40°C - +100°C)	-40°F - +212°F (-40°C - +100°C)	-40°F - +212°F (-40°C - +100°C)	-40°F - +212°F (-40°C - +100°C)
Material	Modified Nitrile Type C2	Modified Nitrile Type C2	Modified Nitrile Type C2	Modified Nitrile Type C2	Modified Nitrile Type C2
Specialized Construction	High tensile steel wire	High tensile steel wire	High tensile steel wire	High tensile steel wire	High tensile steel wire
Media	Hydraulic Fluid	Hydraulic Fluid	Hydraulic Fluid	Hydraulic Fluid	Hydraulic Fluid
Application	Agricultural; Construction	Agricultural; Construction	Agricultural; Construction	Agricultural; Construction	Agricultural; Construction
Part Number	A15081-128	A15081-24	A15082-140	A15082-154	A15082-77
Description	Hose Assembly, 3/8" x 128" (~325,12 cm)	Hose Assembly, 3/8" x 24" (~60,94 cm)	Hose Assembly, 3/8" x 140" (355,60 cm)	Hose Assembly, 3/8" x 154" (~391,16 cm)	Hose Assembly, 3/8" x 77" (~195,58 cm)
Product Category	Hydraulic Hose	Hydraulic Hose	Hydraulic Hose	Hydraulic Hose	Hydraulic Hose
Product Form	Hose; Assembly	Hose; Assembly	Hose; Assembly	Hose; Assembly	Hose; Assembly
I.D.	3/8" (~9,53 mm)	3/8" (~9,53 mm)	3/8" (~9,53 mm)	3/8" (~9,53 mm)	3/8" (~9,53 mm)
O.D.	.62" (~15,75 mm)	.62" (~15,75 mm)	.62" (~15,75 mm)	.62" (~15,75 mm)	.62" (~15,75 mm)
Minimum Bend Radius	2 1/2" (~63,50 mm)	2 1/2" (~63,50 mm)	2 1/2" (~63,50 mm)	2 1/2" (~63,50 mm)	2 1/2" (~63,50 mm)
Working Pressure	3000 PSI (~22408 kPa)	3000 PSI (~22408 kPa)	3000 PSI (~22408 kPa)	3000 PSI (~22408 kPa)	3000 PSI (~22408 kPa)
Temperature Range	-40°F - +212°F (-40°C - +100°C)	-40°F - +212°F (-40°C - +100°C)	-40°F - +212°F (-40°C - +100°C)	-40°F - +212°F (-40°C - +100°C)	-40°F - +212°F (-40°C - +100°C)
Material	Modified Nitrile Type C2	Modified Nitrile Type C2	Modified Nitrile Type C2	Modified Nitrile Type C2	Modified Nitrile Type C2
Specialized Construction	High tensile steel wire	High tensile steel wire	High tensile steel wire	High tensile steel wire	High tensile steel wire
Media	Hydraulic Fluid	Hydraulic Fluid	Hydraulic Fluid	Hydraulic Fluid	Hydraulic Fluid
Application	Agricultural; Construction	Agricultural; Construction	Agricultural; Construction	Agricultural; Construction	Agricultural; Construction
Part Number	A15084-145	A15085-112	A15092-106	A15092-155	A15082-132

HYDRAULIC HOSE INFORMATION (CONTINUED)

Description	Hose Assembly, 3/8" x 145" (~368,30 cm)	Hose Assembly, 3/8" x 112" (~284,48 cm)	Hose Assembly, 3/8" x 106" (~269,24 cm)	Hose Assembly, 3/8" x 155" (~393,70 cm)	Hose Assembly, 3/8" x 132" (~335,28 cm)
Product Category	Hydraulic Hose	Hydraulic Hose	Hydraulic Hose	Hydraulic Hose	Hydraulic Hose
Product Form	Hose; Assembly	Hose; Assembly	Hose; Assembly	Hose; Assembly	Hose; Assembly
I.D.	3/8" (~9,53 mm)	3/8" (~9,53 mm)	3/8" (~9,53 mm)	3/8" (~9,53 mm)	3/8" (~9,53 mm)
O.D.	.62" (15,75 mm)	.62" (15,75 mm)	.62" (15,75 mm)	.62" (15,75 mm)	.62" (15,75 mm)
Minimum Bend Radius	2 1/2" (~63,50 mm)	2 1/2" (~63,50 mm)	2 1/2" (~63,50 mm)	2 1/2" (~63,50 mm)	2 1/2" (~63,50 mm)
Working Pressure	3000 PSI (~22408 kPa)	3000 PSI (~22408 kPa)	3000 PSI (~22408 kPa)	3000 PSI (~22408 kPa)	3000 PSI (~22408 kPa)
Temperature Range	-40°F - +212°F (-40°C - +100°C)	-40°F - +212°F (-40°C - +100°C)	-40°F - +212°F (-40°C - +100°C)	-40°F - +212°F (-40°C - +100°C)	-40°F - +212°F (-40°C - +100°C)
Material	Modified Nitrile Type C2	Modified Nitrile Type C2	Modified Nitrile Type C2	Modified Nitrile Type C2	Modified Nitrile Type C2
Specialized Construction	High tensile steel wire	High tensile steel wire	High tensile steel wire	High tensile steel wire	High tensile steel wire
Media	Hydraulic Fluid	Hydraulic Fluid	Hydraulic Fluid	Hydraulic Fluid	Hydraulic Fluid
Application	Agricultural; Con- struction	Agricultural; Con- struction	Agricultural; Con- struction	Agricultural; Con- struction	Agricultural; Con- struction
Part Number	A3292	A21533-36	A3371	A15026	A15092-90
Description	Hose Assembly, 3/8" x 22" (~55,88 cm)	Hose Assembly, 3/4" x 36" (~91,44 cm)	Hose Assembly, 3/4" x 25" (~63,50 cm)	Hose Assembly, 3/8" x 98" (~248,92 cm)	Hose Assembly, 3/8" x 90" (~228,60 cm)
Product Category	Hydraulic Hose	Hydraulic Hose	Hydraulic Hose	Hydraulic Hose	Hydraulic Hose
Product Form	Hose:Assembly	Hose; Assembly	Hose; Assembly	Hose; Assembly	Hose; Assembly
I.D.	3/8" (~9,53 mm)	3/4" (~19,05 mm)	3/4" (~19,05 mm)	3/8" (~9,53 mm)	3/8" (~9,53 mm)
O.D.	.69" (~17,46 mm)	1.06" (~26,92 mm)	1.06" (~26,92 mm)	.69" (17,46 mm)	.69" (17,46 mm)
Minimum Bend Radius	2 1/2" (~63,50 mm)	4 3/4" (~120,65 mm)	4 3/4" (~120,65 mm)	2 1/2" (63,50 mm)	2 1/2" (63,50 mm)
Working Pressure	3000 PSI (~20684 kPa)	2250 PSI (~15513 kPa)	2250 PSI (~15513 kPa)	3000 PSI (22407,96 kPa)	3000 PSI (22407,96 kPa)
Temperature Range	-40°F - +212°F (-40°C - +100°C)	-40°F - +212°F (-40°C - +100°C)	-40°F - +212°F (-40°C - +100°C)	-40°F - +212°F (-40°C - +100°C)	-40°F - +212°F (-40°C - +100°C)
Material	Modified Nitrile Type C2	Modified Nitrile Type C2	Modified Nitrile Type C2	Modified Nitrile Type C2	Modified Nitrile Type C2
Specialized Construction	High tensile steel wire	High tensile steel wire	High tensile steel wire	High tensile steel wire	High tensile steel wire
Media	Hydraulic Fluid	Hydraulic Fluid	Hydraulic Fluid	Hydraulic Fluid	Hydraulic Fluid
Application	Agricultural; Con- struction	Agricultural; Con- struction	Agricultural; Con- struction	Agricultural; Con- struction	Agricultural; Con- struction

HYDRAULIC HOSE INFORMATION (CONTINUED)

Part Number	A15094-175	A15098-150	A18668-152	A21518-120	A21525-77	A21530-140
Description	Hose Assembly, 3/8" x 175" (~444,50 cm)	Hose Assembly, 3/8" x 150" (~381,00 cm)	Hose Assembly, 3/8" x 152" (~386,08 cm)	Hose Assembly, 5/8" x 120" (~304,80 cm)	Hose Assembly, 5/8" x 77" (~195,58 cm)	Hose Assembly, 5/8" x 140" (~355,60 cm)
Product Category	Hydraulic Hose	Hydraulic Hose	Hydraulic Hose	Hydraulic Hose	Hydraulic Hose	Hydraulic Hose
Product Form	Hose; Assembly	Hose; Assembly	Hose; Assembly	Hose; Assembly	Hose; Assembly	Hose; Assembly
I.D.	3/8" (9,53 mm)	3/8" (9,53 mm)	3/8" (9,53 mm)	5/8" (15,88 mm)	5/8" (15,88 mm)	5/8" (15,88 mm)
O.D.	.69" (17,46 mm)	.62" (15,75 mm)	.81" (20,64 mm)	.94" (23,81 mm)	.94" (23,81 mm)	.94" (23,81 mm)
Minimum Bend Radius	2 1/2" (63,50 mm)	2 1/2" (63,50 mm)	3 1/2" (88,90 mm)	4" (101,60 mm)	4" (101,60 mm)	4" (101,60 mm)
Working Pressure	3000 PSI (22407,96 kPa)	3000 PSI (22407,96 kPa)	3000 PSI (22407,96 kPa)	2750PSI (18960,58 kPa)	2750PSI (18960,58 kPa)	2750PSI (18960,58 kPa)
Temperature Range	-40°F - +212°F (-40°C - +100°C)	-40°F - +212°F (-40°C - +100°C)	-40°F - +212°F (-40°C - +100°C)	-40°F - +212°F (-40°C - +100°C)	-40°F - +212°F (-40°C - +100°C)	-40°F - +212°F (-40°C - +100°C)
Material	Modified Nitrile Type C2	Modified Nitrile Type C2	Modified Nitrile Type C2	Modified Nitrile Type C2	Modified Nitrile Type C2	Modified Nitrile Type C2
Specialized Construction	High tensile steel wire	High tensile steel wire	High tensile steel wire	High tensile steel wire	High tensile steel wire	High tensile steel wire
Media	Hydraulic Fluid	Hydraulic Fluid	Hydraulic Fluid	Hydraulic Fluid	Hydraulic Fluid	Hydraulic Fluid
Application	Agricultural; Construction	Agricultural; Construction	Agricultural; Construction	Agricultural; Construction	Agricultural; Construction	Agricultural; Construction
Part Number	A15084-110	A15081-12	A1421	A21533-30	A12011	A15085-120
Description	Hose Assembly, 3/8" x 110" (~279,40 cm)	Hose Assembly, 3/8" x 12" (~30,48 cm)	Hose Assembly, 1/2" x 84" (~213,36 cm)	Hose Assembly, 3/4" x 30" (~76,20 cm)	Hose Assembly, 3/8" x 20" (~50,80 cm)	Hose Assembly, 3/8" x 120" (~304,80 cm)
Product Category	Hydraulic Hose	Hydraulic Hose	Hydraulic Hose	Hydraulic Hose	Hydraulic Hose	Hydraulic Hose
Product Form	Hose:Assembly	Hose:Assembly	Hose; Assembly	Hose; Assembly	Hose; Assembly	Hose:Assembly
I.D.	3/8" (~9,53 mm)	3/8" (~9,53 mm)	1/2" (~12,70 mm)	3/4" (~19,05 mm)	3/8" (~9,53 mm)	3/8" (~9,53 mm)
O.D.	.69" (~17,46 mm)	.69" (~17,46 mm)	0.81" (~20,57 mm)	1.06" (26,99 mm)	.69" (17,46 mm)	.69" (~17,46 mm)
Minimum Bend Radius	2 1/2" (~63,50 mm)	2 1/2" (~63,50 mm)	3 1/2" (88,90 mm)	4 3/4" (~120,65 mm)	2 1/2" (63,50 mm)	2 1/2" (~63,50 mm)
Working Pressure	3000 PSI (~20684 kPa)	3000 PSI (~20684 kPa)	3000 PSI (22407,96 kPa)	2250 PSI (~15513 kPa)	3000 PSI (22407,96 kPa)	3000 PSI (~20684 kPa)
Temperature Range	-40°F - +212°F (-40°C - +100°C)	-40°F - +212°F (-40°C - +100°C)	-40°F - +212°F (-40°C - +100°C)	-40°F - +212°F (-40°C - +100°C)	-40°F - +212°F (-40°C - +100°C)	-40°F - +212°F (-40°C - +100°C)
Material	Modified Nitrile Type C2	Modified Nitrile Type C2	Modified Nitrile Type C2	Modified Nitrile Type C2	Modified Nitrile Type C2	Modified Nitrile Type C2
Specialized Construction	High tensile steel wire	High tensile steel wire	High tensile steel wire	High tensile steel wire	High tensile steel wire	High tensile steel wire
Media	Hydraulic Fluid	Hydraulic Fluid	Hydraulic Fluid	Hydraulic Fluid	Hydraulic Fluid	Hydraulic Fluid
Application	Agricultural; Construction	Agricultural; Construction	Agricultural; Construction	Agricultural; Construction	Agricultural; Construction	Agricultural; Construction

HYDRAULIC HOSE INFORMATION (CONTINUED)

Part Number	A12092	A18631-42	A15081-95	A1491	A18627	A21531-288
Description	Hose Assembly, 3/8" x 127" (~322,58 cm)	Hose Assembly, 1/2" x 42" (~106,68 cm)	Hose Assembly, 3/8" x 95" (~241,30 cm)	Hose Assembly, 1/2" x 246" (~624,84 cm)	Hose Assembly, 1/2" x 180" (~457,20 cm)	Hose Assembly, 5/8" x 288" (~731,52 cm)
Product Category	Hydraulic Hose	Hydraulic Hose	Hydraulic Hose	Hydraulic Hose	Hydraulic Hose	Hydraulic Hose
Product Form	Hose; Assembly	Hose; Assembly	Hose:Assembly	Hose; Assembly	Hose; Assembly	Hose:Assembly
I.D.	3/8" (9,53 mm)	1/2" (~12,70 mm)	3/8" (~9,53 mm)	1/2" (~12,70 mm)	1/2" (~12,70 mm)	5/8" (~15,88 mm)
O.D.	.69" (17,46 mm)	.78" (19,81 mm)	.69" (~17,46 mm)	.78" (19,81 mm)	.78" (~19,81 mm)	.94" (~23,81 mm)
Minimum Bend Radius	2 1/2" (63,50 mm)	3 1/2" (88,90 mm))	2 1/2" (~63,50 mm)	3 1/2" (88,90 mm))	3 1/2" (88,90 mm))	4" (~101,60 mm)
Working Pressure	3000 PSI (22407,96 kPa)	3000 PSI (22407,96 kPa)	3000 PSI (~20684 kPa)	3000 PSI (22407,96 kPa)	3000 PSI (22407,96 kPa)	2750 PSI (~18961 kPa)
Temperature Range	-40°F - +212°F (-40°C - +100°C)	-40°F - +212°F (-40°C - +100°C)	-40°F - +212°F (-40°C - +100°C)	-40°F - +212°F (-40°C - +100°C)	-40°F - +212°F (-40°C - +100°C)	-40°F - +212°F (-40°C - +100°C)
Material	Modified Nitrile Type C2	Modified Nitrile Type C2	Modified Nitrile Type C2	Modified Nitrile Type C2	Modified Nitrile Type C2	Modified Nitrile Type C2
Specialized Construction	High tensile steel wire	High tensile steel wire	High tensile steel wire	High tensile steel wire	High tensile steel wire	High tensile steel wire
Media	Hydraulic Fluid	Hydraulic Fluid	Hydraulic Fluid	Hydraulic Fluid	Hydraulic Fluid	Hydraulic Fluid
Application	Agricultural; Construction	Agricultural; Construction	Agricultural; Construction	Agricultural; Construction	Agricultural; Construction	Agricultural; Construction
Part Number	A25504-186	A18676-184				
Description	Hose Assembly, 3/8" x 186" (~472,44 cm)	Hose Assembly, 1/2" x 184" (~467,36 cm)				
Product Category	Hydraulic Hose	Hydraulic Hose				
Product Form	Hose:Assembly	Hose; Assembly				
I.D.	3/8" (~9,53 mm)	1/2" (~12,70 mm)				
O.D.	.62" (15,75 mm)	.78" (~19,81 mm)				
Minimum Bend Radius	2 1/2" (~63,50 mm)	3 1/2" (88,90 mm))				
Working Pressure	3000 PSI (~20684 kPa)	3000 PSI (22407,96 kPa)				
Temperature Range	-40°F - +212°F (-40°C - +100°C)	-40°F - +212°F (-40°C - +100°C)				
Material	Modified Nitrile Type C2	Modified Nitrile Type C2				
Specialized Construction	High tensile steel wire	High tensile steel wire				
Media	Hydraulic Fluid	Hydraulic Fluid				
Application	Agricultural; Construction	Agricultural; Construction				

TOWING PLANTER



DANGER

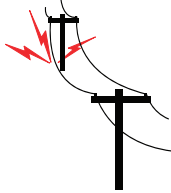

Contacting or coming close to power lines or other high energy sources will cause death or serious injury.

Keep away from power lines or high energy sources at all times.



WARNING

All safety/warning lights, reflective decals, and SMV sign must be in place and visible before transporting machine on public roads or death, serious injury, and damage to property and equipment may result. Check federal, state/provincial, and local regulations before transporting equipment on public roads.



WARNING

Transporting planter with hoppers over half full or unevenly loaded can cause loss of control and could result in death, serious injury, or damage to property and equipment. Properly load planter when transporting. Be aware of extra transport weight, and road conditions and limits.

- Tow only with farm tractor rated and configured for equipment.
- Know your route and be aware of any obstructions.
- Follow all road and bridge load limit restrictions.
- Never exceed maximum transport towing speed of 20 km/h.

PLANTING SPEED

NOTICE

Raise planter out of ground when making sharp turns or backing up or equipment damage may result.

Planters are designed to operate within a speed range of 2 to 8 mph (~3 - 13 km/h). See [“General Planting Rate Information” on page 5-1](#). Variations in ground speed produce variations in rates.

NOTE: Seed spacing can be adversely affected at speeds above 5.5 mph (~9 km/h).

CONTACT DRIVE SPRING ADJUSTMENT

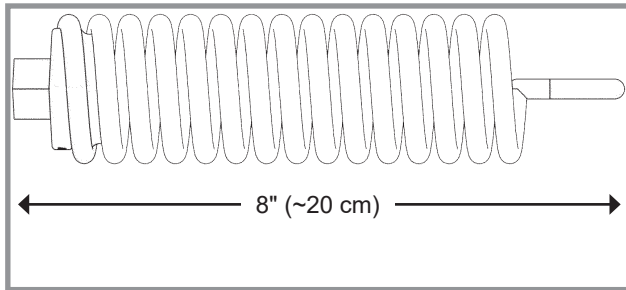

Spring length measurement (Factory setting)



Down pressure spring location

There are two down pressure springs on each contact drive wheel. Spring tension is factory preset and normally requires no adjustment.

Basic setting for spring tension is approximately 200 lb (~91 kg) of down force at tire contact point.

NOTE: Measurement must be taken in planting position with proper tire pressure.

SEED RATE TRANSMISSION ADJUSTMENT

Seed rate transmissions allow simple, rapid changes of sprockets to obtain desired planting population. By removing lynch pins on hexagon shafts, sprockets can be interchanged with those from the sprocket storage rod bolted to the transmission.

Chain tension is controlled by a spring-loaded dual-sprocket idler. The idler assembly is equipped with an easy-release idler arm to remove spring tension for replacing sprockets.

Planting rate charts in the Seed Meter Operation section will aid you in selecting correct sprocket combinations.

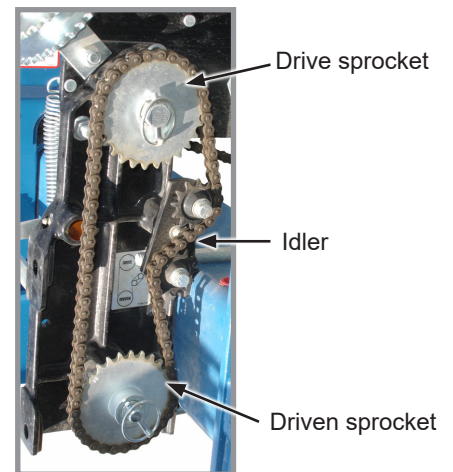

Seed rate transmission chain tension

SHEAR PROTECTION

Shear pins protect the planter driveline and row unit components from damage.

1. Determine where binding has occurred before replacing a pin. Turn shaft by hand (with the aid of a wrench) and check for misalignment and seized parts.
2. When shaft can be turned by hand (with the aid of a wrench) replace shear pins with same size and type. Spare shear pins are in wheel module storage area.

NOTICE	Misaligned drill shaft/transmission coupler can cause equipment damage.
---------------	--

3. Check driveline alignment and follow prescribed lubrication schedules to prevent component binding or breakage.

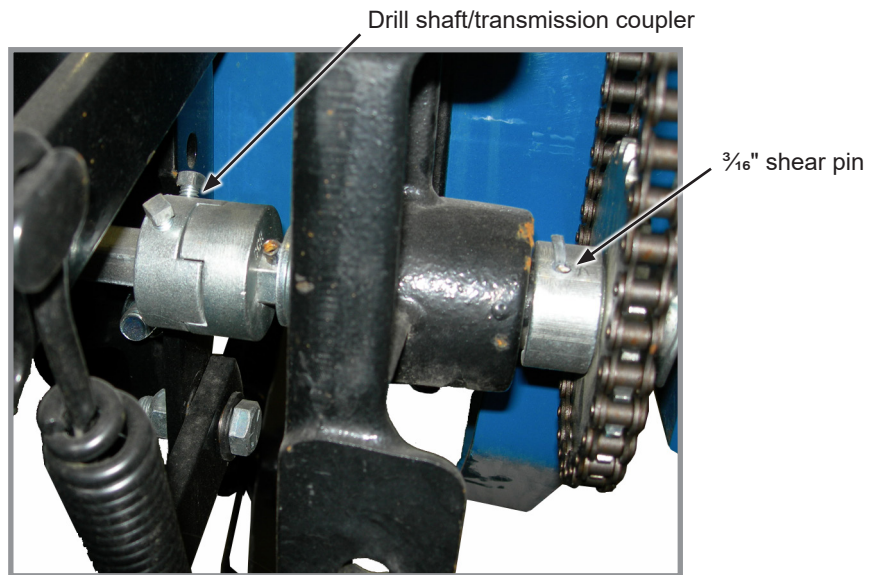

Transmission shaft and drill shaft coupler

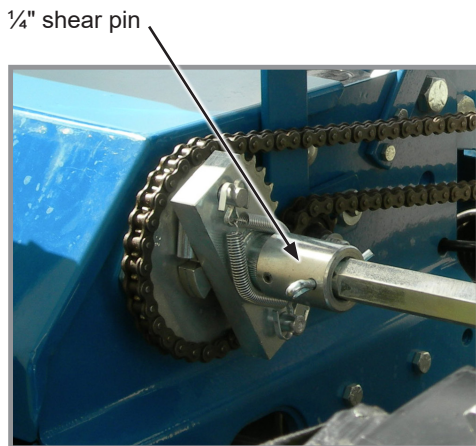

Liquid fertilizer driveline

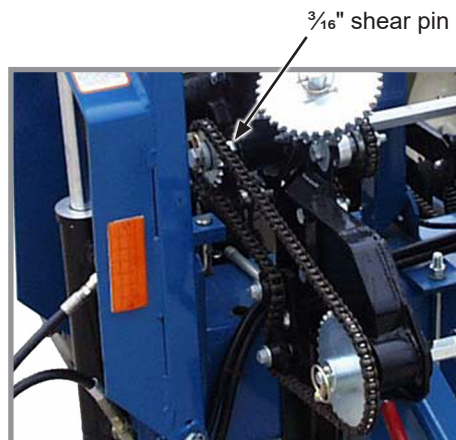

Dry fertilizer driveline

WRAP SPRING WRENCH

Chain idlers use wrap spring wrenches to release and adjust transmission chain tension.

NOTE: Wrap spring wrenches are L.H. and R.H. specific. L.H. styles have silver metal or grey plastic release collars. R.H. styles have gold metal or blue plastic release collars.

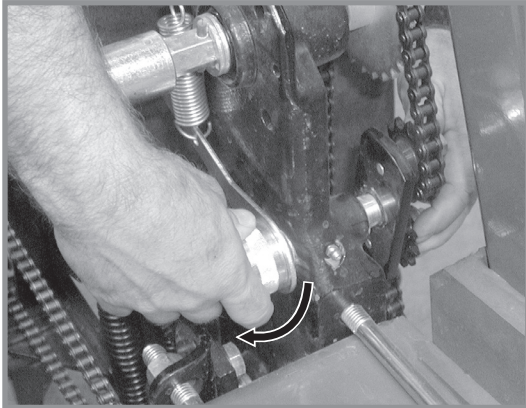

Release chain tension

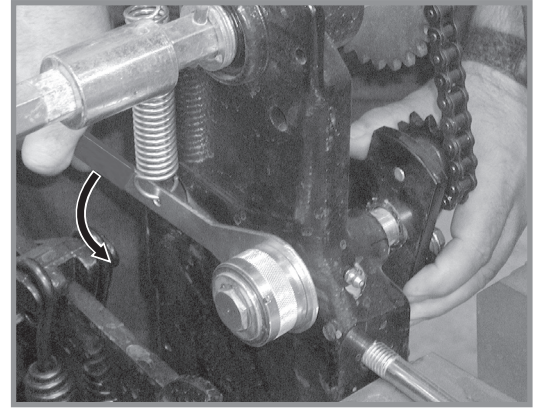

Increase chain tension

Rotate wrap spring wrench knurled collar while rotating chain idler away from chain to release chain tension.

Rotate chain idler into chain while rotating handle to tension idler spring.

CONTACT WHEEL DRIVE SPROCKETS

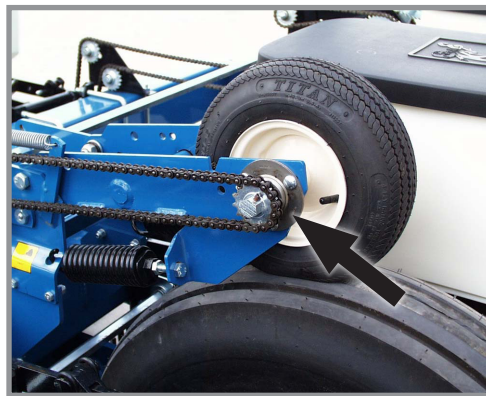

Contact wheel drive sprocket

NOTE: 15 tooth, 19 tooth or 30 tooth drive sprockets at each contact drive wheel can be interchanged from sprocket storage rod bolted to each transmission. 30 tooth sprockets require use of 124 pitch chains instead of standard 116 pitch No. 40 chains.

Chain tension is controlled by a spring-loaded sprocket idler. Amount of spring tension on chain is controlled by idler arm. Planting rate chart in Rate Chart section will aid you in selecting correct sprocket.

NOTE: 15, 19, and 30 tooth drive sprockets are NOT applicable to all rate charts. 23 tooth driven sprocket at reverser plate is changed to a 17 tooth sprocket when using 60 cell soybean seed disc. Check chart titles to ensure proper rate chart is selected.

NOTE: Make a field check after each sprocket combination adjustment to be sure you are planting at desired rate.

ROW MARKER SPEED ADJUSTMENT

NOTICE

Excessive row marker travel speed can damage row markers. Adjust flow controls before row markers are first used.

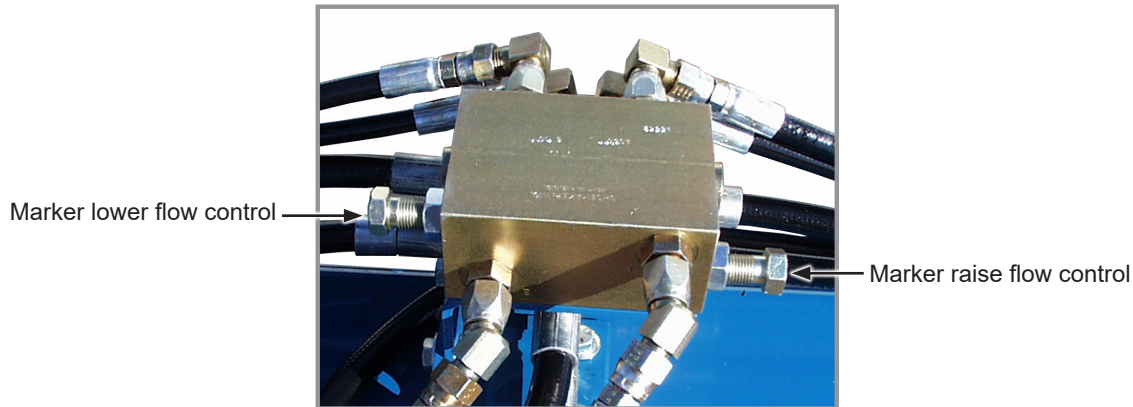

Row marker flow control valves

Two flow control valves determine amount of oil flow restriction controlling row marker travel speeds. One flow control valve controls lowering speed and one controls raising speed of both markers.

NOTE 1: Hydraulics operate slowly when oil is cold. Make all adjustments with oil warm.

NOTE 2: On a tractor where oil flow cannot be controlled, tractor flow rate may be greater than rate marker cylinder can accept. Hold tractor hydraulic control lever until cylinder reaches end of its stroke. This occurs most often on tractors with an open center hydraulic system.

NOTE 3: On tractors with a closed center hydraulic system, set hydraulic flow control so detent functions properly.

1. Loosen jam nut and turn control clockwise (IN) to slow speed or counterclockwise (OUT) to increase speed.
2. Tighten jam nut after adjustments are made.

EVEN-ROW PUSH ROW UNIT

An Even-Row Push Row Unit Package is available to add one additional push row unit on outer L.H. side of front toolbar for use with Solid Row Split Row Package.

NOTE: See “Row Marker Adjustment” for determining correct length to set row marker assemblies when planting with even-row push row unit option.

An inner hitch with a 7½" (19 cm) offset mount is available from Kinze through your Kinze Dealer to plant two 15" rows between last year's 30" rows and avoid tire damage from stalks by driving off row

NOTE: install hitch onto 2-point hitch bar using R.H. hole if 2-Point Hitch Option is used. A 7½" (19 cm) offset mount is not needed. See “Offset Hitch Adjustment” for additional information.

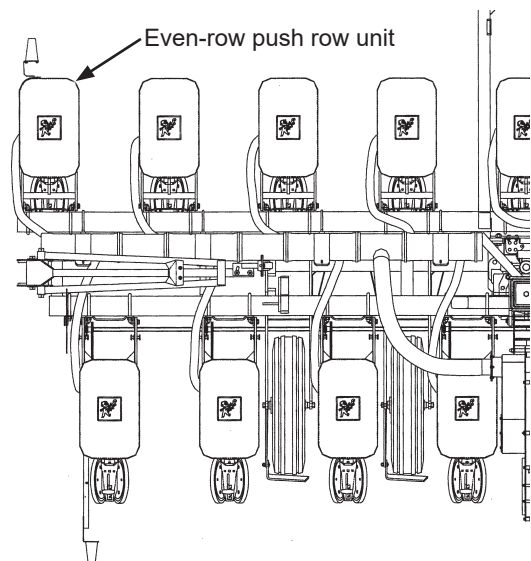

ROW MARKER ADJUSTMENTS

1. Multiply number of rows by the average row spacing in inches to determine total planting width.

Row Marker Lengths	
8 Row 70 cm	560 cm
8 Row 35 cm	525 cm

2. Lower planter and row marker assembly to ground.
3. Measure from planter center line to a point where blade contacts ground.
4. Adjust row marker extension so distance from marker disc blade to center line of planter is equal to total planting width. Adjust right and left row marker assemblies equally and securely tighten clamping bolts.

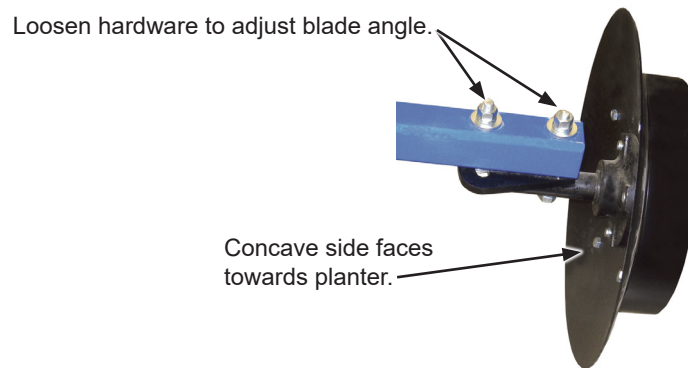

Row marker disc blade angle adjustment

NOTICE

Setting marker disc blade assembly at a sharper angle than needed adds stress to row marker assembly and shortens bearing and blade life. Set blade angle only as needed to leave a clear mark.

Marker disc blade is installed with concave side facing inward. Spindle assembly is slotted so hub and blade can be angled to throw more or less dirt.

5. Loosen hardware and move assembly as required.
6. Tighten bolts to specified torque.
7. Do a field test to ensure markers are properly adjusted.

NOTE: A notched marker blade is available from Kinze through your Kinze Dealer for use in more severe no till conditions.

ROW MARKER EVEN-ROW LENGTH ADJUSTMENT

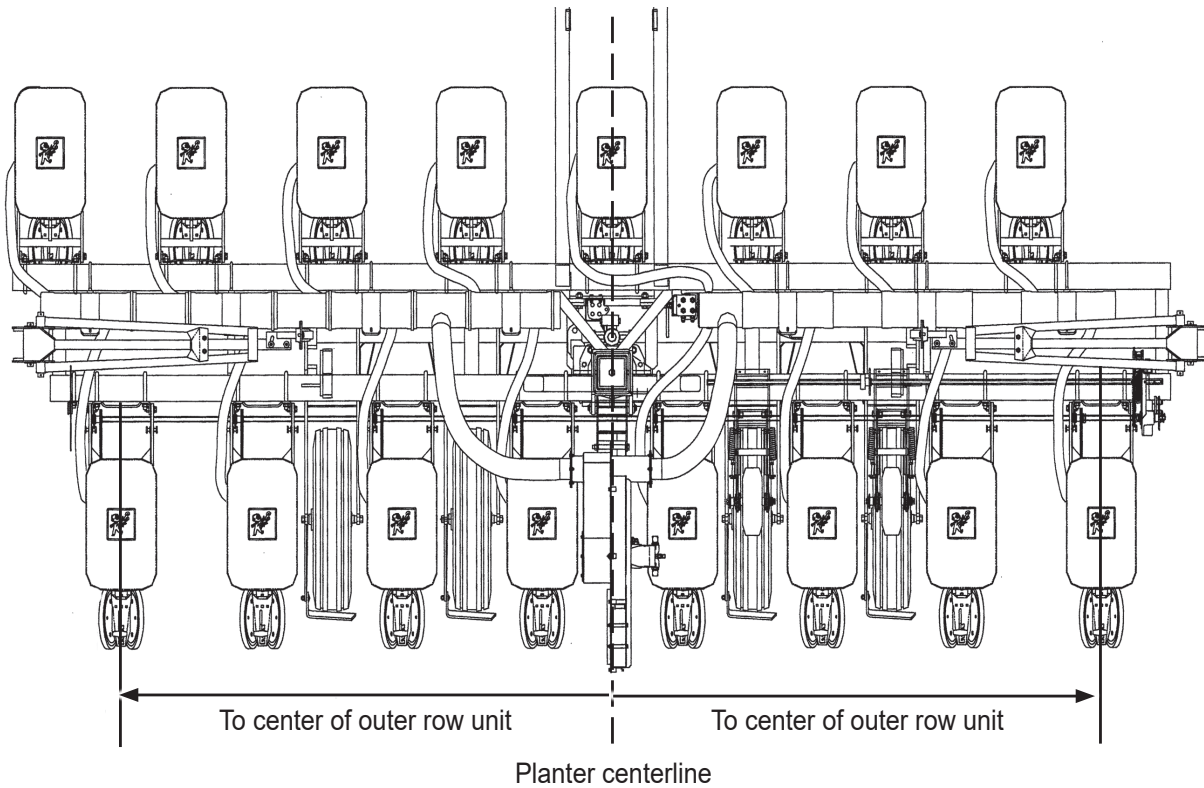

Center of planter to center of outer row unit. $\times 2 + 35 \text{ cm}$ = Row spacing. Dimension between planter center line and marker blade

8 Row 70 cm with 8 interplant push row units
 (L.H. marker $280 \text{ cm} \times 2 + 35 \text{ cm} = 595 \text{ cm}$)
 (R.H. marker $245 \text{ cm} \times 2 + 35 \text{ cm} = 525 \text{ cm}$)

NOTE: Readjust markers when planting 70 cm rows

Number of rows \times row spacing (Centimeters)

=

Dimension between planter center line and marker blade

8 Rows \times 70 cm Spacing = 560 cm Marker Dimension

VACUUM METER SYSTEM

Kinze vacuum meter seed metering system includes seed meters, seed discs, and an air system consisting of a hydraulic driven vacuum fan which draws air through manifolds, hoses, and seed meters on each row unit.

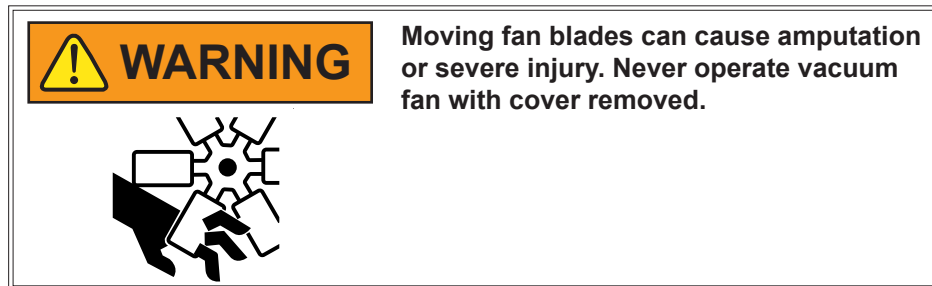

ANALOG VACUUM OR PRESSURE GAUGE

Analog vacuum or pressure gauge connects directly to vacuum meter (vacuum) or bulk fill (pressure) manifold and is tied into digital sending units.

Only adjustment is to “zero” needle with no vacuum or pressure present. If there is a significant difference between gauge and a reading taken at meters, a different manifold location should be found to connect hose to gauge and digital sending unit.

NOTE: Analog gauges are identical EXCEPT for plug and hose barb locations in side of gauge housing. DO NOT connect vacuum meter or bulk fill hose to wrong gauge. Check plug and hose barb installation if readout is erratic or appears inaccurate.

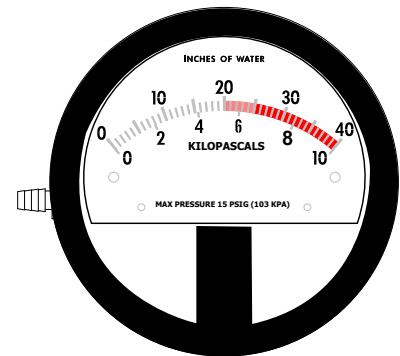

Analog Gauge

BULK FILL SYSTEM



CAUTION

Seed flying out of disconnected delivery tube at high velocity can cause injury. Do not disconnect delivery tubes when system is operating.

NOTICE

Foreign materials can plug system. Make sure seed is clean and free of debris when filling bulk fill hoppers.

NOTICE

Do not turn on system with tractor engine at full speed or system damage may occur.

NOTICE

Do not operate bulk fill system above maximum system operating pressure of 20 inches (~51 cm) of water or seed bridging may occur.

1. Before filling hoppers refer to "Row Unit Operation" for additives information. Fill hoppers with seed, latch lids, and secure with pin.
2. Start bulk fill system with tractor engine at idle.
3. Increase engine speed to full and set initial system pressure using flow control valve.
4. Allow system to warm up and adjust pressure if necessary.

Recommended pressures:

- Corn – 12" (~30 cm) of water
- Soybeans – 10" (~25 cm) of water
- Sunflower – see ["Vacuum Settings" on page 3-10.](#)
- Actual pressure needed is affected by seed size, shape, and coating.

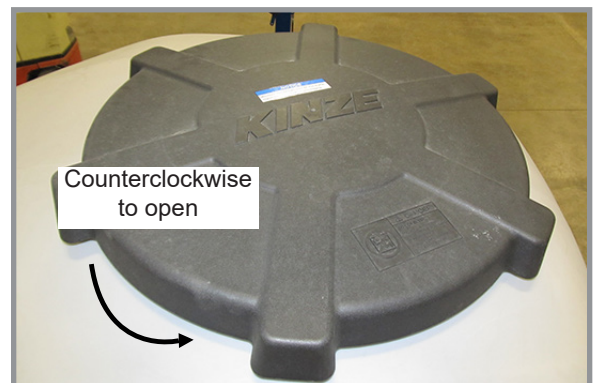

Bulk fill tank lid latch

BULK FILL ENTRAINER ACCESS

1. Shut down bulk fill system.
2. Loosen wing nut and turn retainer holding shutoff door in its storage location.
3. Remove rubber plug closest to area in entrainer needing attention.
4. Insert shutoff door into open slot and push into entrainer at a slight upward angle.
5. When work is complete, remove shutoff door, return door to storage location, and plug open slot.

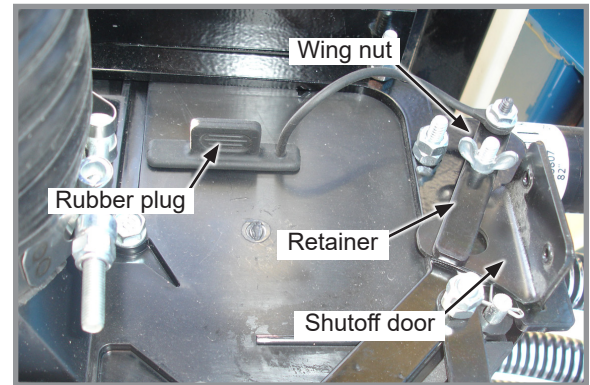

Bulk fill entrainer (end view)

BULK FILL TANKS - CLEAN OUT

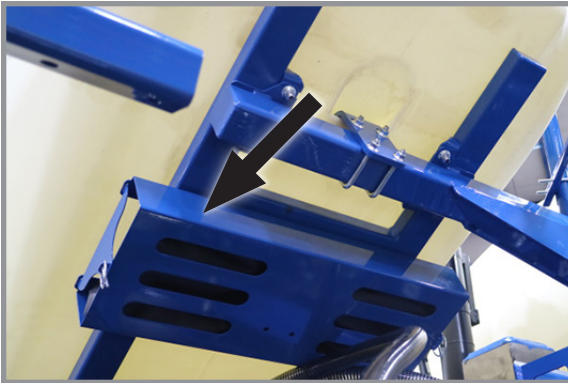

Cleanout chute storage bracket

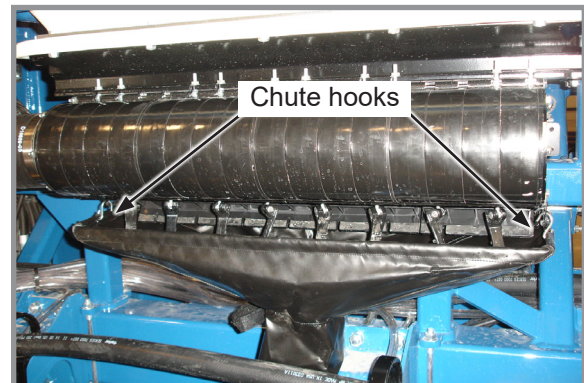

Cleanout chute installed

1. Remove bulk fill tank cleanout chute from storage location beneath catwalk.
2. Position tube of chute under entrainer and attach hooks on each end of entrainment assembly.
3. Open cleanout doors and empty tank.
4. Close all cleanout doors and return cleanout chute to storage location.

RIDGE PLANTING

Planter toolbar height can be raised 3" (~8 cm) for ridge planting.

Relocate 20" (~51 cm) transport axles to lower hole in wheel arm.

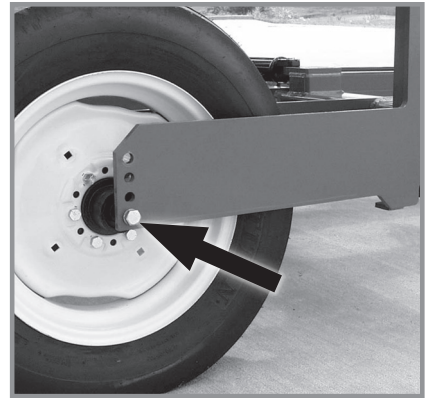

Transport axle in lowest position

TIRE SCRAPER

A tire scraper prevents buildup of dirt and mud between wheel arm assembly and tire.

Adjust scraper so it does not contact tire.

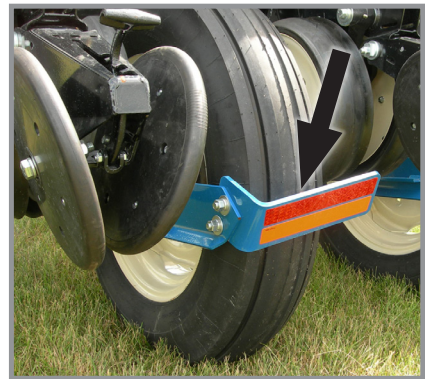

Tire scraper

AUXILIARY WORK LIGHTS PACKAGE

Auxiliary Work Lights Package includes two LED flood lamps, brackets, and hardware to mount lights and a wiring harness to plug into existing planter light harness.



Auxiliary work lights

REAR TRAILER HITCH

NOTICE

Rear trailer hitch is designed for use with piston pump only. Maximum allowable hitch weight is 200 lb (~91 kg). Do not exceed 6,000 lb (~2722 kg) gross towing weight or the equivalent of a loaded 500 gal (~1893 l) tank and running gear or equipment can be damaged.

Rear Trailer Hitch is used to tow a 3 or 4 wheel wagon behind planter.

A spring, chain and mounting bracket are used to support the 1¼" (~4 cm) feed hose from hitch to piston pump. This extra length or loop is required to allow planter to be moved into transport position without stretching or breaking hose.

NOTE: Periodically check feed hose for kinks to prevent restricted delivery rate.

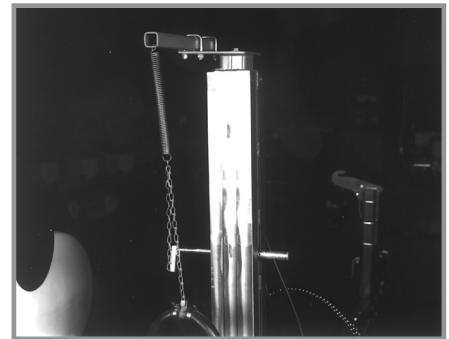

Rear hitch hose support

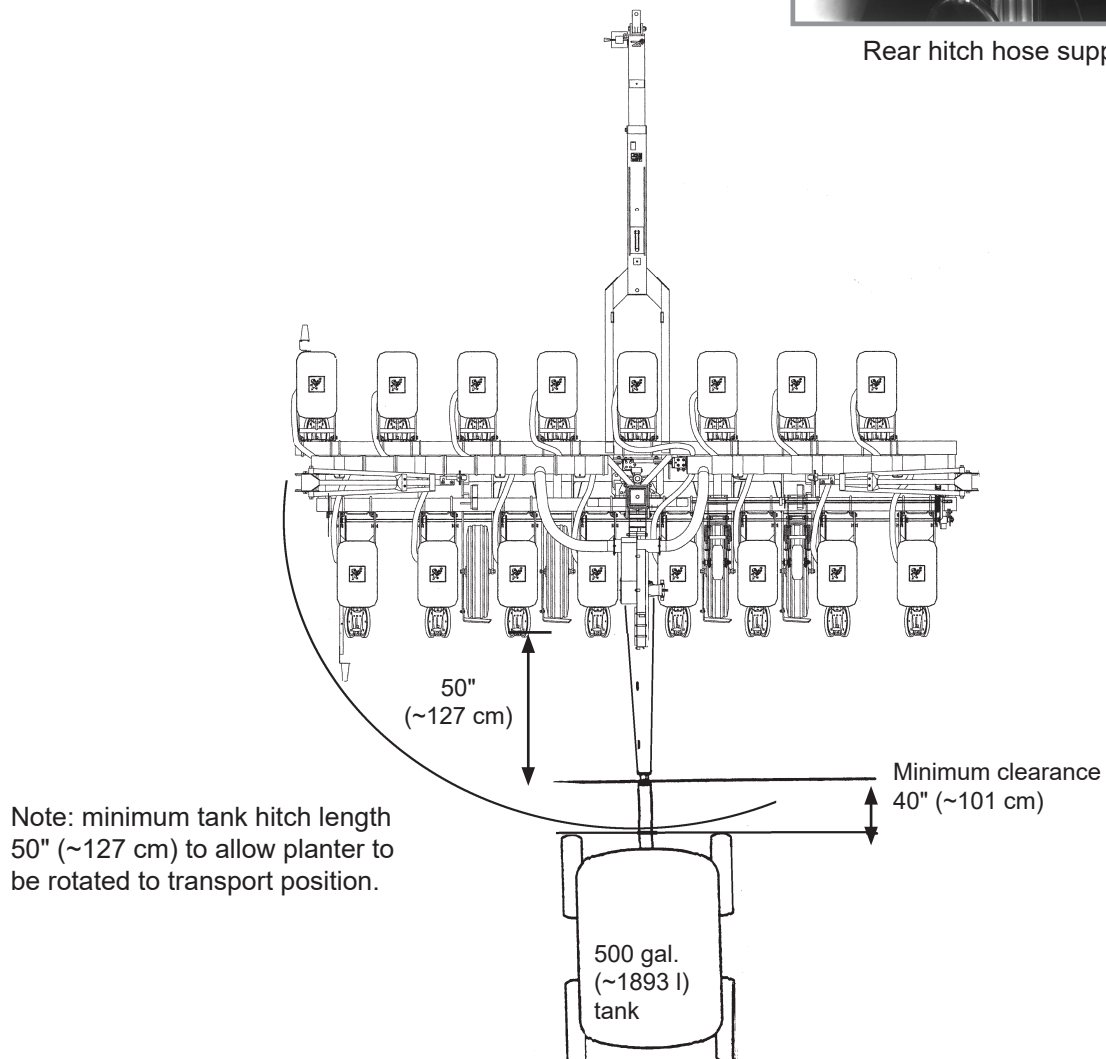

FIELD TEST

Perform a field test with any change of field and/or planting conditions, seed size or planter adjustment to ensure proper seed placement and operation of row units. See [“Cylinder Information” on page 2-17](#), [“Granular chemical field check” on page 2-37](#)

- Check planter for front to rear and lateral level operation. See [“Level Planter” on page 2-16](#)
- Check all row units to be certain they are running level. Row unit parallel arms should be approximately parallel to the ground when planting.
- Check row markers for proper operation and adjustment. See [“Row Marker Speed Adjustment” on page 2-27](#).
- Check for proper application rates and placement of granular chemicals on all rows. See [“Granular Chemical Application Field Check” on page 2-37](#).
- Check for desired depth placement and seed population on all rows. See [“Check Seed Population” on page 2-35](#).
- Check for proper application rates of fertilizer on all rows. See [“Dry Fertilizer Application Rates” on page 5-12](#)

Reinspect machine after field testing.

- Hoses And Fittings
- Bolts And Nuts
- Cotter Pins And Spring Pins
- Drive Chain Alignment

CHECK SEED POPULATION

1. Tie up one or more sets of closing wheels by running a chain or rubber tarp strap between the hopper support panel and closing wheels. It may be necessary to decrease closing wheel arm spring tension.

Chain, rubber tarp strap, or similar.

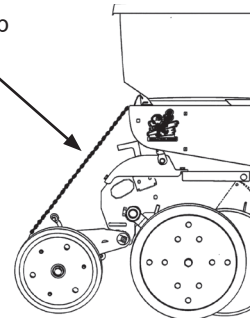

2. Plant a short distance and check to see if seed is visible in the seed trench. Adjust planting depth to a shallower setting if seed is not visible and recheck.

Planting depth adjustment handle

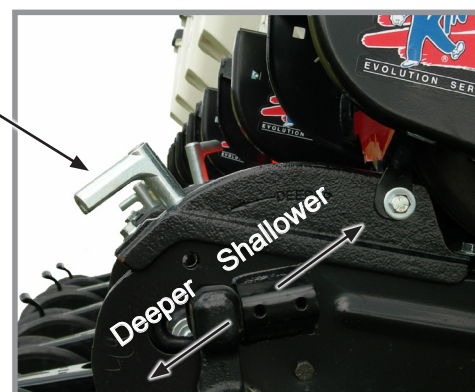

Planting depth adjustment

3. Measure $\frac{1}{1000}$ of a hectare. See chart for correct distance for row width being planted. For example, if planting 70 cm rows $\frac{1}{1000}$ of a hectare would be 14,28 m.

$\frac{1}{1000}$ Hectare Seed Population Count Row Width/Distance		
Row Width	35 cm	70 cm
Distance	28,56 m	14,28 m

NOTE: Seeds may bounce or roll when planting with closing wheels raised and planting depth set shallow affecting seed spacing accuracy.

4. Count seeds in measured distance.
5. Multiply number of seeds placed in $\frac{1}{1000}$ of a hectare by 1000. This gives total population.

EXAMPLE: 70 cm row spacing 14,28 m equals $\frac{1}{1000}$ hectare.
26 seeds counted x 1000 = 26000 seeds per hectare

Seed count can be affected by drive wheel and seed meter drive ratio, tire pressure, and/or seed meter malfunction.

1. If seed check shows average distance between seeds is significantly different than seed rate chart indicates, first check drive ratio between drive wheel and seed meter. Check drive wheel air pressure, check for incorrect sprocket(s) in driveline and check drive and driven sprockets on transmission(s) for proper selection.
2. Check for seed meter malfunction. ["Vacuum Seed Meter" on page 7-4.](#)

DETERMING LITERS PER HECTARE

kilograms per hectare \div Seed unit weight = Liters per hectare

Average Unit Weight of:

Soybeans unit weight = 0,773 kg/l



Milo/Grain Sorghum unit weight = 0,757 kg/l

Cotton unit weight = 0,412 kg/l

If seed population check shows planting rate is significantly different than seed rate chart shows or if a particular meter is not planting accurately, see ["Vacuum Seed Meter" on page 7-4.](#)

GRANULAR CHEMICAL APPLICATION FIELD CHECK

Temperature, humidity, speed, ground conditions, flowability of different material, or meter obstructions can affect granular chemical rate of delivery.

 WARNING	<p>Agricultural chemicals can cause death or serious injury to persons, animals, and plants or seriously damage soil, equipment, or property. Read and follow all chemical and equipment manufacturers labels and instructions.</p>
	

Perform a field check to determine application rates.

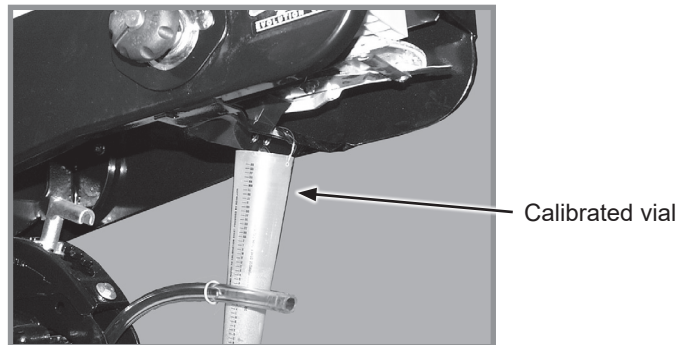

Granular chemical field check

1. Fill insecticide and/or herbicide hoppers.
2. Attach a calibrated vial to each granular chemical meter.

NOTE: Disengage clutch to avoid dropping seed during test.

3. Lower planter and drive 1320 feet (~400 meters) at planting speed.
4. Weigh chemical in grams caught in one vial.
5. Multiply that amount by factor shown to determine kilograms per hectare.

Kg per hectare	
Row Width	Factor
70 cm	0,0301
35 cm	0,0150

EXAMPLE: You are planting 70 cm rows. You have planted for 400 meters at the desired planting speed. You caught 337 grams of chemical in one vial. 337 grams times 0,0301 equals 10,144 kilograms per hectare.

NOTE: Check calibration of all rows.

METERING GATE

Use metering gate setting as a starting point for distributing insecticide or herbicide. Charts are based on 5 mph (~8 km/h) planting speed. Use a higher gate setting for speeds faster than 5 mph (~8 km/h) and a lower setting for speeds slower than 5 mph (~8 km/h).

WATER TANK

The water tank is to only be filled with clean water or preferably potable water (water meeting local standards for drinking). The tank holds 4 gallons (~15 l) of water. Be sure to check for regulations pertaining to this use. Tank should be filled with new water at the beginning of each planting season and drained at the end of each planting season.

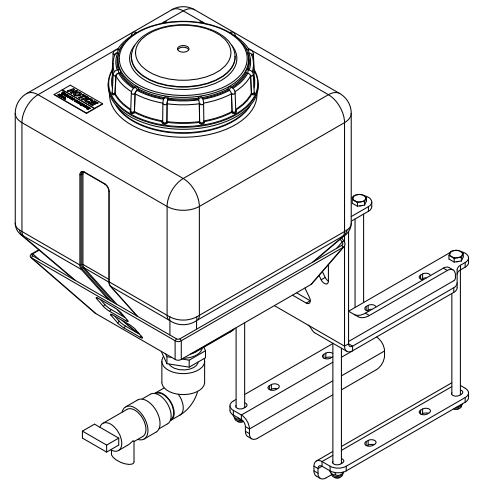

NOTICE

Drain tank if environmental conditions are 32° Fahrenheit (0° Celsius) or below to prevent tank from cracking.

The water tank is to be used in the event of an accidental exposure to chemical. Chemicals are supplied with Material Safety Data Sheets (MSDS) that provide full information about the chemical, its effects on exposure, and first aid needs in the event of an emergency. Keep your MSDS file up-to-date and available for first responders in case of emergency.

If the water tank is used seek medical assistance immediately for further treatment.

PLANTING DEPTH

Planting depth is maintained by adjustable row unit gauge wheels. Depth adjustment range is approximately 1/2" to 3 1/2" (~1,2 to 8,8 cm).

1. Raise planter to remove weight from wheels.
2. Push down on depth adjustment handle and reposition it forward to decrease or rearward to increase planting depth. Initially adjust all units to the same setting.
3. Lower planter and check operation and planting depth of all row units. Readjust individual rows as needed for uniform operation.

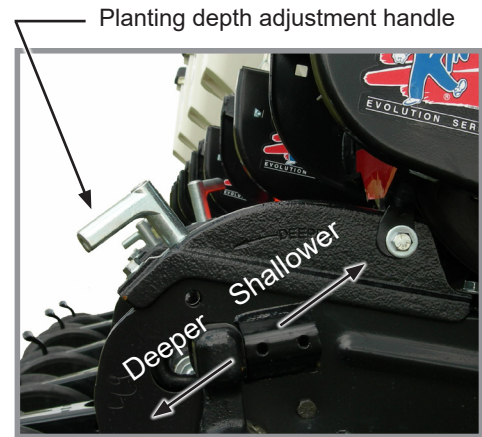

Planting depth adjustment

“V” CLOSING WHEEL ADJUSTMENT (RUBBER OR CAST IRON)

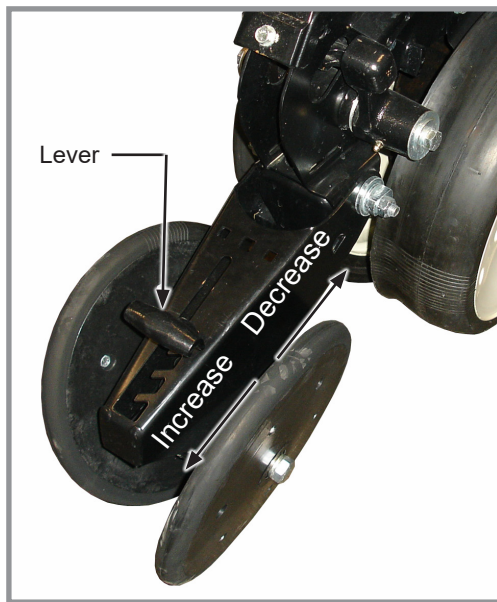

“V” Closing wheels installed offset

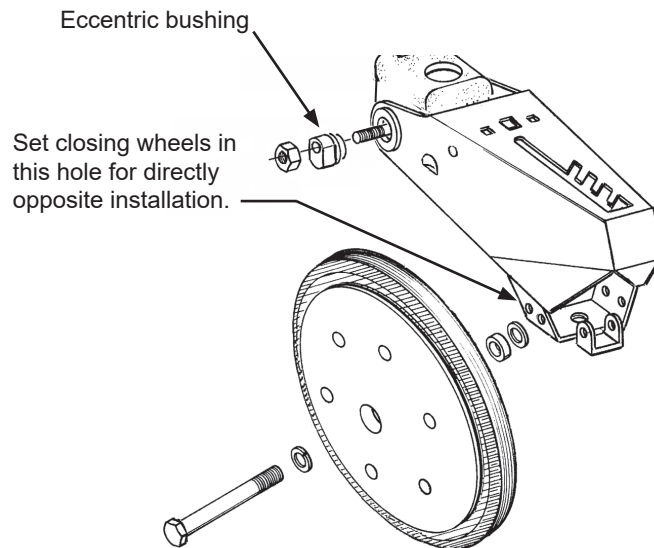

“V” closing wheels should have enough down pressure to close the seed trench and ensure good soil to seed contact. Move 5-position quick adjustable down force lever on the top of closing wheel arm to the rear to increase closing wheel spring pressure. Move lever forward to decrease pressure. Adjust all row units to a similar setting. Light soil usually requires less down force at average depth, approximately 2" (~5 cm) while heavy soil requires increased down force.

Eccentric bushings in the wheel arm stop allow for lateral adjustment of the “V” closing wheel assembly. Use a 3/4" wrench to loosen hardware attaching closing wheel arm to wheel arm stop. Use another 3/4" wrench to turn eccentric bushings until closing wheels are aligned with seed trench. Tighten hardware.

Closing wheels can be installed “offset” (to improve residue flow) or “directly” opposite. Use forward installation holes if set “directly” opposite.

SEED HOPPERS

Vacuum seed hopper has a capacity of 1.75 bushels (~64 liters).

Use clean seed and make certain there are no foreign objects inside when filling seed hopper. Replace hopper lids after hoppers are filled to prevent accumulation of dust or dirt in seed meter which can cause premature wear.

Periodically empty hoppers completely to remove any foreign objects and to ensure proper seed meter operation.

Disengage meter drive and hopper latch and lift hopper off hopper support. See "Seed Meter Drive Release" below.



Seed Hopper

SEED METER DRIVE RELEASE

A clutch release mechanism disengages seed meter drive from seed meter to remove seed hopper. Disconnecting drive allows operator to check granular chemical application rates without dropping seed. It also allows one or more rows to be disconnected when finishing fields.

Turn knob ¼ turn counterclockwise to disengage or ¼ turn clockwise to engage.

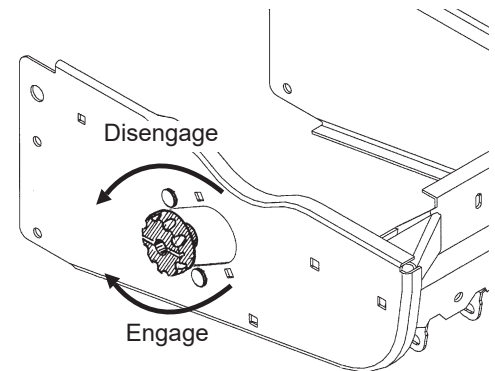

Seed meter drive release

ROW UNIT EXTENSION BRACKETS

Row unit extension brackets extend row units rearward 4" (10,16 cm) to provide clearance for coulter mounted residue wheels and HD single disc fertilizer openers.

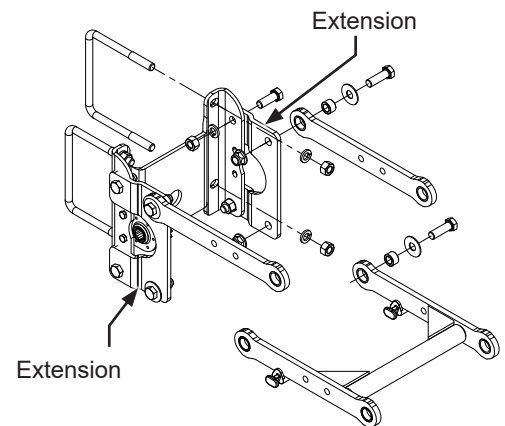

Row unit extension brackets

ROW UNIT CHAIN ROUTING

Row unit drive chains must be properly tensioned and aligned for proper operation and to minimize wear.

Inspect and replace weak, worn or broken springs, idlers, and idler bushings.

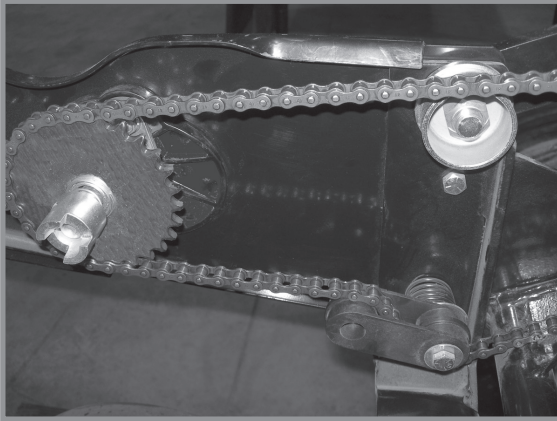

Vacuum pull row unit meter drive

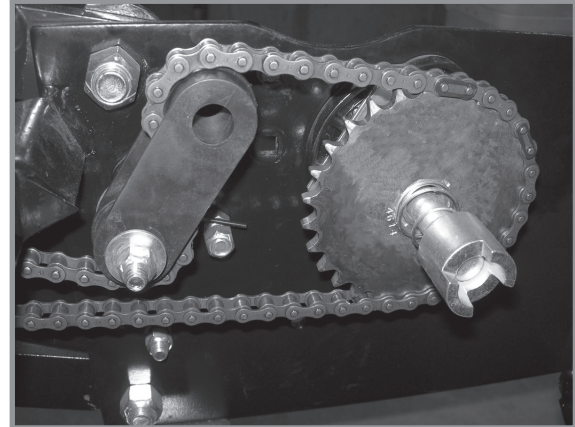

Vacuum push row unit meter drive

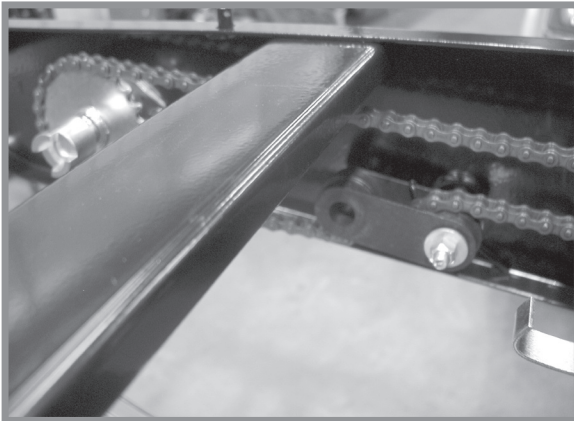

Row unit granular chemical drive

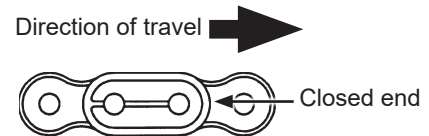

NOTE: Install connector link with closed end facing direction of travel.

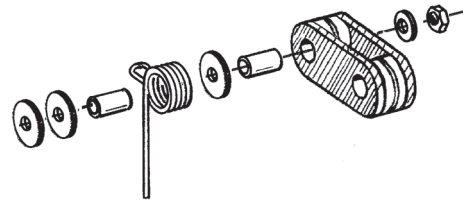

NOTE: Reverse idler when worn on one side for extended use.

QUICK ADJUSTABLE DOWN FORCE SPRINGS OPTION

Quick adjustable down force springs increase penetration in hard soil and keep row unit from bouncing in rough field conditions. Two springs per row, one on each side parallel arms, are used unless equipped with row unit mounted no till coulters. Four springs per row are used with row unit mounted no till coulters.

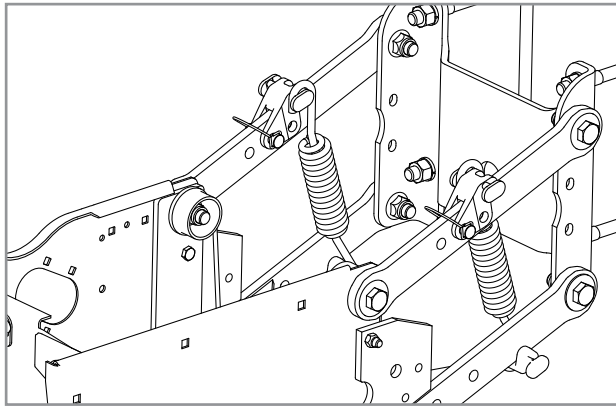

Two Springs Per Row (Dual)

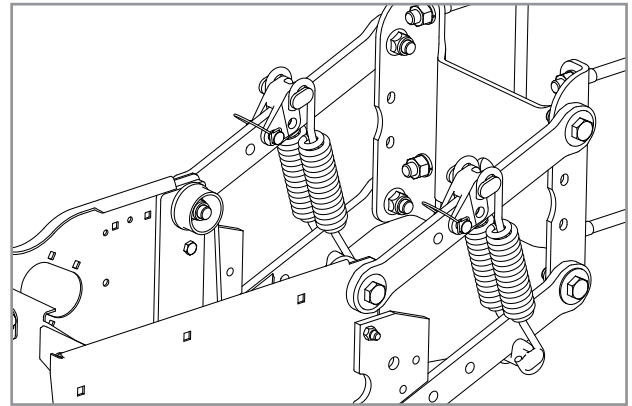

**Four Springs Per Row (Quad)
(Row Unit Mounted No Till Coulters Only)**

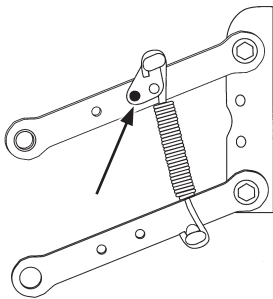

Position 1 (Least)

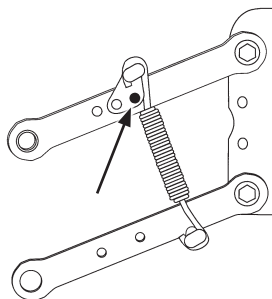

Position 2

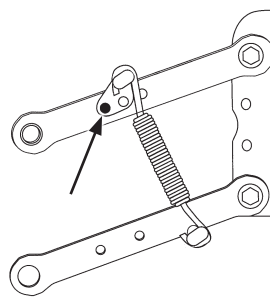

Position 3

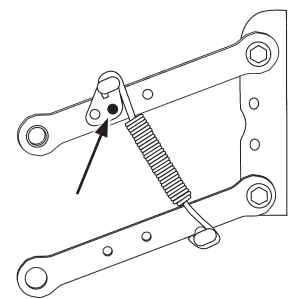

Position 4 (Most)

There are four positions to set down pressure spring tension.

NOTICE	Springs must be installed with open side of spring hooks toward seed hoppers to prevent binding on spring mount adjustment pins.
---------------	---

1. Raise planter and remove spring mount pin at top of spring.
2. Slide mount to desired position and install pin.

NOTE: Adjust springs for field conditions. Too much down pressure in hard field conditions can cause row units to lift planter and keep drive wheels from making contact. Too much down pressure in soft field conditions can cause row unit to run too deep.

Heavy Duty Spring Down Force Pressure*		
	2 Springs	4 Springs
Position	Heavy Duty P/N: D21337	Heavy Duty P/N: D21337
1	43 lb (19.5 kg)	80 lb (36.3 kg)
2	86 lb (39.0 kg)	144 lb (65.3 kg)
3	167 lb (75.7 kg)	307 lb (139.3 kg)
4	249 lb (113.0 kg)	470 lb (213.2 kg)

*Pressure does not include weight of row unit, seed, or options.

PNEUMATIC DOWN PRESSURE PACKAGE (PDP) OPTION

Row unit down pressure can be adjusted on-the-go as field conditions change with pneumatic down pressure option. A cab-mounted control box adjusts pressure (Older models may have a digital readout). A planter-mounted 12 VDC air compressor with 3 gallon capacity air tank supplies air for the down pressure system.

Packages include upper and lower air spring mounting castings for pull row units (front and rear air spring mounting castings for push row units), 150 psi rated air springs, 3/8" O.D. nylon hoses, dual solenoid air valve and stainless steel, 160 psi, 2" liquid-filled gauge and planter wiring harness.

PDP provides a maximum of 218 kg of downforce per each row unit.

Pneumatic down pressure row unit extension brackets are required in some applications.

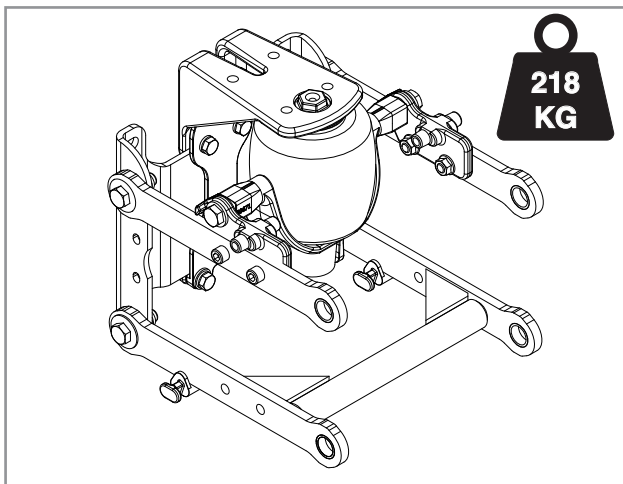

Pull Row Unit Air Spring

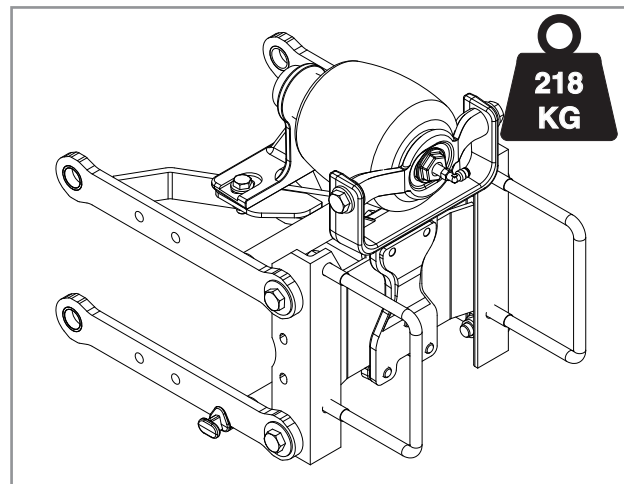

Push Row Unit Air Spring

NOTE: If additional down pressure is needed with the Pneumatic Down Pressure Package, assist springs are available through your Kinze dealer. One spring is installed on the outer side of the parallel arms on each side of the row unit as shown below.

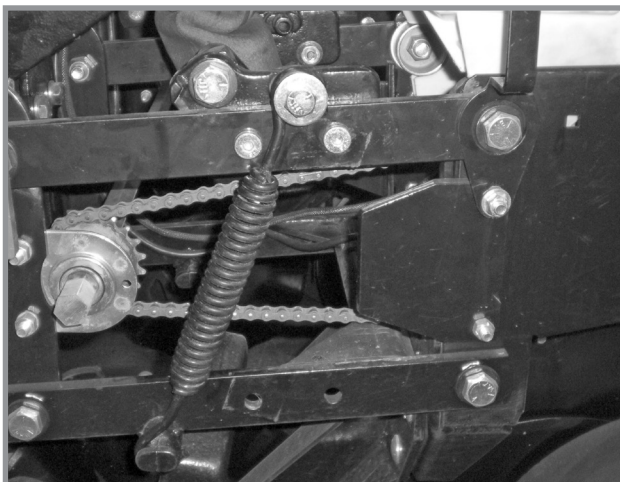

Pull Row Unit Assist Springs

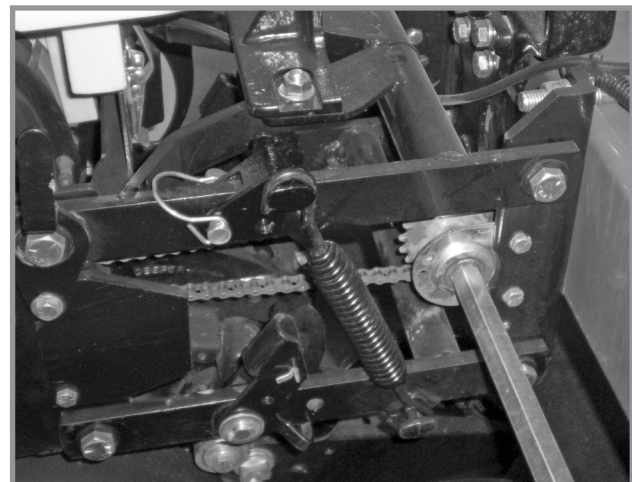

Push Row Unit Assist Springs

FIELD OPERATION

NOTE: Adjust down pressure with planter lowered and row openers in ground for most accurate adjustment. Pressure can be adjusted from tractor using control console, or at planter using manual control valves on compressor assembly.



Control console

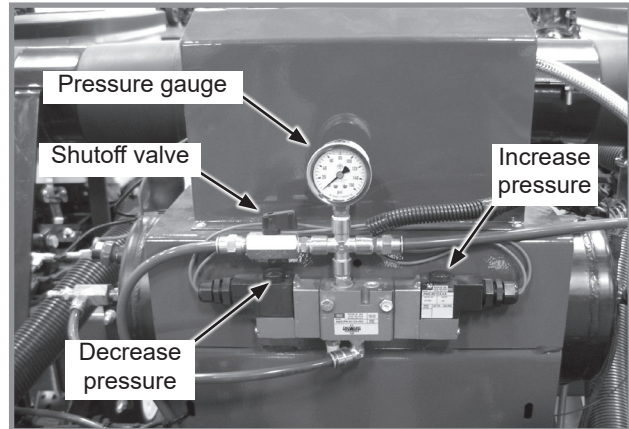

Air compressor assembly controls

ADJUST DOWN PRESSURE FROM CAB

Push toggle switch left to increase or right to decrease pressure.

For models equipped with a Blue Vantage monitor, use the monitor to adjust down pressure. Refer to your Blue Vantage manual for more information.

ADJUST DOWN PRESSURE AT PLANTER

Push and hold decrease or increase button on compressor assembly to decrease or increase pressure.



NOTE: Value on the air pressure gauge is NOT down pressure force. Multiply air pressure (PSI) by four (4) to calculate down pressure (lbs).

LOCK UP PUSH ROW UNITS EQUIPPED WITH PNEUMATIC DOWN PRESSURE SPRINGS

1. Press and hold button on solenoid until pressure gauge reads 0-5 PSI.
2. Lock up units. See [“Split Row Push Unit Lockups” on page 6-3](#) for instructions.
3. Turn shutoff valve handle perpendicular to valve body to turn off push row unit air supply.

SPLIT ROW PUSH UNIT LOCKUPS

Split Row Push Unit Lockups lock push units in their raised position.

	<p>Improper lifting of row units can cause serious injury. An empty row unit requires minimum 84 lb (38.1 kg) lift. Set down pressure springs to minimum, lower planter to ground, and empty seed hopper before attempting to lift with this lever.</p>
	

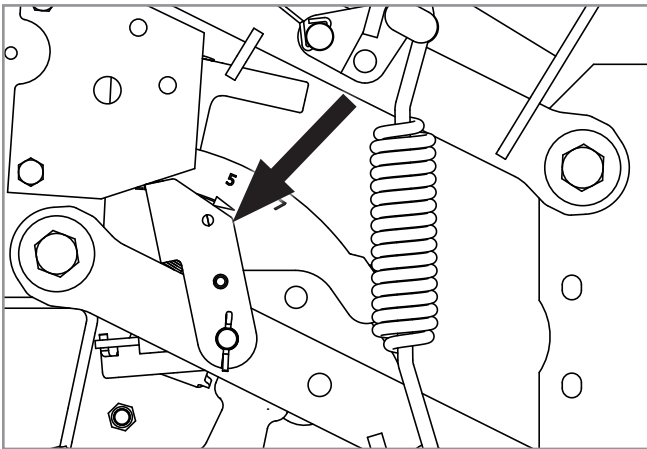

Push Row Unit Locked In Raised Position

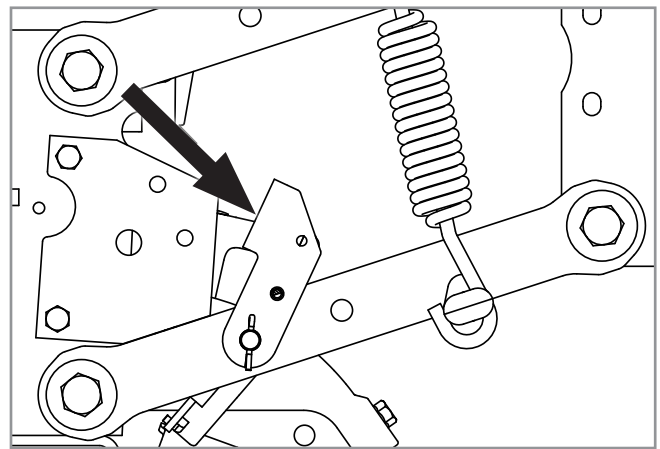

Lockup Released For Field Operation

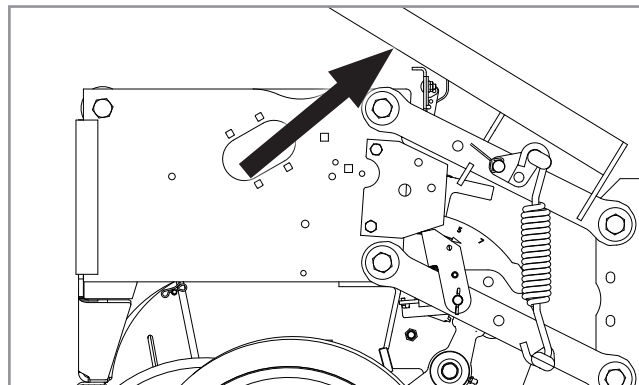

Lift lever positioned on push row unit

To lock in raised position:

1. Set row unit down pressure springs to minimum setting.
2. Lower the planter to the planting position.
3. Empty seed hoppers.
4. On each split row lockup, flip the spring tab forward.
5. Using the lift lever, raise the push row unit to allow the spring loaded lockups to snap into locked position under the row unit stops.
6. Repeat Steps 4 and 5 on remaining push row units.

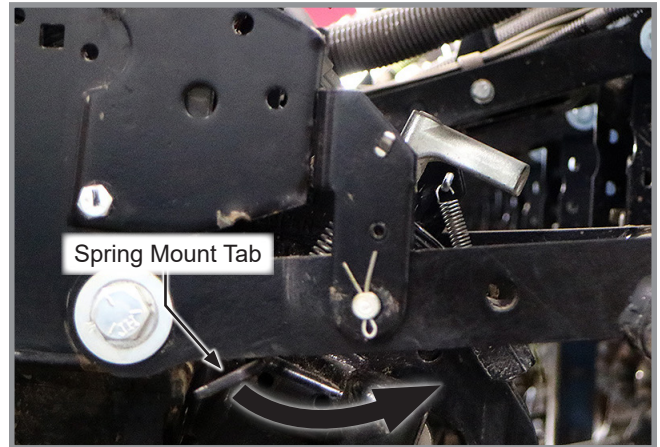

To release lockups:

1. Lower the planter to the planting position.
2. On each split row lockup, flip the spring tab rearward.
3. Using the lift lever, raise the push row unit to allow the spring loaded lockups to snap out of locked position. Lower row unit to the ground.
4. Repeat Step 3 on remaining push row units.

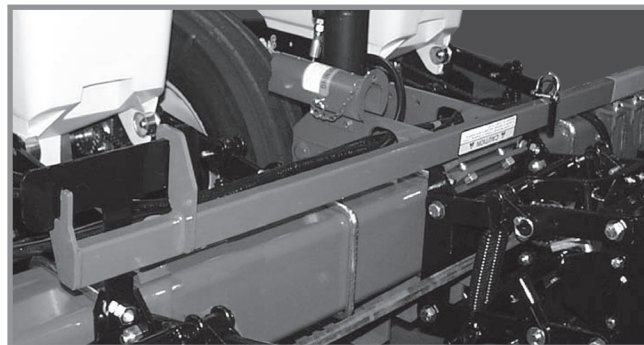
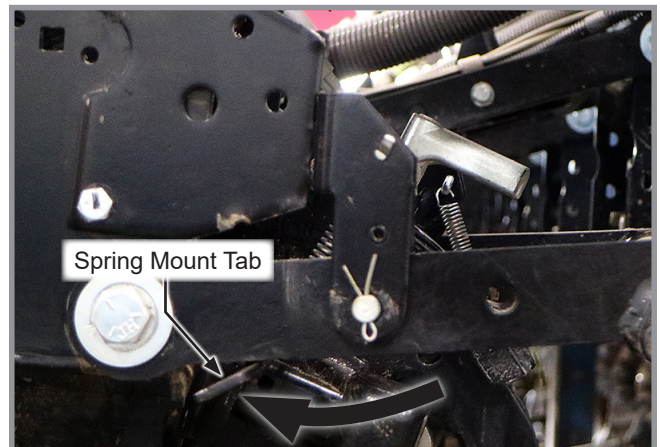

Lift lever in storage location

SPLIT ROW PUSH ROW UNIT CLUTCH SPROCKET

Push row unit clutch sprocket disengages Split Row drive from push row unit drill shaft when only pull row units are used.

DISENGAGE

Rotate knurled collar $\frac{1}{4}$ turn. Rock drill shaft slightly using a $\frac{7}{8}$ " wrench to take pressure off of spring loaded pins in clutch to allow pins to "pop" out, disengaging drive.

ENGAGE

Rotate knurled collar $\frac{1}{4}$ turn and turn drill shaft with a $\frac{7}{8}$ " wrench until drive pins engage drive sprocket.

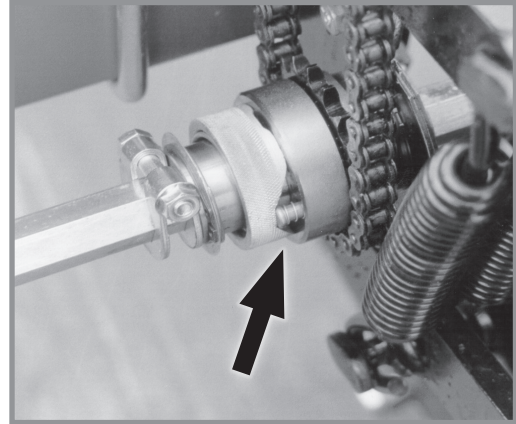

Split Row clutch sprocket



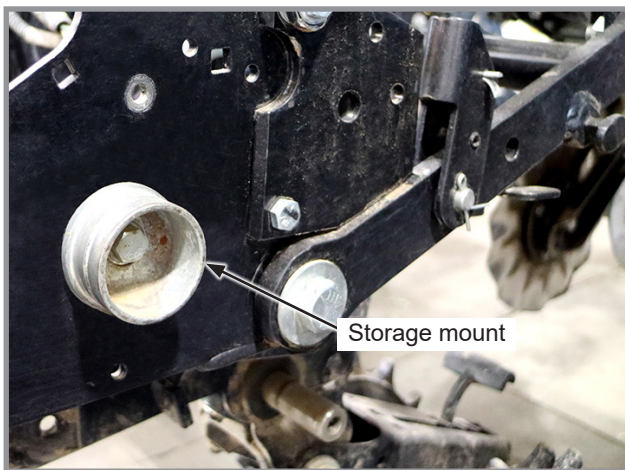







SPLIT ROW PUSH ROW UNIT VACUUM HOSE SHUTOFF



Split Row vacuum hose shutoff

When push row units are not used, move row unit end of 2" (5 cm) vacuum hose on each push row unit to storage mount located on side of shank.

VACUUM SETTINGS

Crop		**Seed Disc Kit	Seed Disc Part No.	Ejector Wheel (Color)	Cells	Seed Size Range	Singulator Zone Setting	Vacuum Setting Inches of Water (cm)	Lubricant
	Corn ‡ Large Sweet Corn	G11152X	B1219 (Light Blue)	1 row 5 punches (Light Blue)	40	2500-5000 seeds/kg	2	18-20 (46-51)	Graphite* Talc*
	Soybean	G11047X	B1232 (Black)	2 rows 6 punches (Black)	120	4850-8820 seeds/kg	0	10-14 (25-36)	Graphite* Talc*
	Sugar Beet	G11154X	B1229 (Dark Orange)	1 row 6 punches (Dark Orange)	60	Pelletized	2	15 (38)	Graphite*
	Milo	G11154X	B1229 (Dark Orange)	1 row 6 punches (Dark Orange)	60	22000-44000 seeds/kg	2	15 (38)	Graphite* Talc*
	Sunflower ‡ Small Sweet Corn	G11153X	B1230 (Gray)	1 row 5 punches (Gray)	40	Oil seeds #2, 3, 4	2	12-18 (30-46)	Graphite* Talc*
	Sunflower	G11153X	B1230 (Gray)	1 row 5 punches (Gray)	40	Oil seeds #5	2	5-8 (13-20)	Graphite* Talc*
	Specialty Disc 1	G11105X	BB1233 (Green)	1 row 6 punches (Green)	60	Cotton	2	15-20 (38-51)	Graphite* Talc as needed*
	Specialty Disc 2	G11106X	B1235 (Brown)	1 row 6 punches (Green)	60	Black turtle & navy edible beans	2	15-20 (38-51)	Graphite* Talc as needed*
	Specialty Disc 3	G11107X	B1234 (Dark Blue)	1 row 6 punches (Green)	60	Pinto & Great Northern edible beans & low-rate soybean	2	15-20 (38-51)	Graphite* Talc as needed*
	Rapeseed	G11046X	B1239 (Dark Gray)	1 row 10 punches (Dark Gray)	83	See "Rapeseed Planting Section" on page 3-18	0	See "Rapeseed Planting Section" on page 3-18	Kinze Brand Graphite Only
	Wheat Disc	G11332X	10783001 (Red)	3 rows 9 punches (Red)	231	17,600-44,000 seeds/kg	§N/A	15-24 (38-61)	Graphite* Talc as needed*

Install selected seed disc. Position vacuum cover on meter by aligning keyhole slots over bolt heads. Push cover on meter and turn counter clockwise to lock in place.

*For More information on application rate, see Additives section.

**Includes seed disc, ejector wheel, and spring.

‡Conventional hoppers only, not applicable with bulk fill.

§Wheat disc wiper must be installed, refer to [“Wheat Disc Wiper Installation” on page 3-12](#)

NOTE: See [“Check Seed Population” on page 2-35](#) for more information. Always field check seed population to ensure planting rates are correct.

NOTE: Singulator settings are marked from 0 - 3.

NOTE: Mixing seed sizes and shapes affects meter performance. Use consistent seed size and shape.

NOTE: Use 1 tablespoon powdered graphite with each standard hopper fill of seed. Seed treatment, foreign material, dirt or seed chaff may cause gradual reduction of seed disc fill (population). See [“Additives” on page 3-16](#)

NOTE: Excessive seed treatment, humidity, and light-weight seed can affect meter performance. Use ½ cup (~118 ml) of talc with each standard hopper fill of seed and mix thoroughly to coat all seeds and adjust rates as needed. Use of talc aids seed flow into meter, singulation, and disc seed drop.

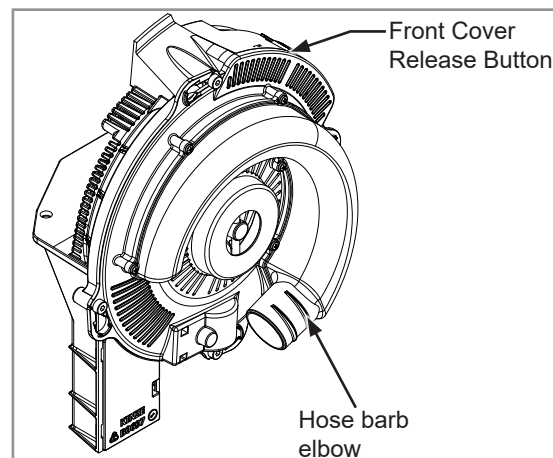
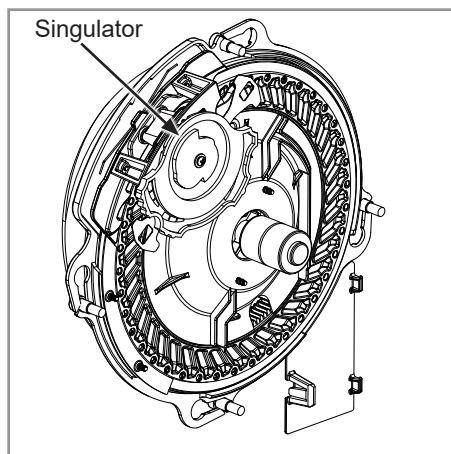

NOTE: Foreign material in seed disc orifices, such as seed chips, hulls, stems, etc., may affect seed delivery. Clean seed ensures accurate seed metering from vacuum seed meter. Remove Seed discs daily to check for buildup of foreign material in seed disc orifices.

Air inlet screens allow air to enter system and aids in keeping field residue or other foreign material out of meter.

See [“Vacuum Seed Meter Maintenance” on page 6-14](#) and [“Preparing Planter for Storage” on page 6-30](#) in Lubrication and Maintenance section for more information.

WHEAT DISC WIPER INSTALLATION

1. Disengage seed drive and remove seed hopper and meter.
2. Rotate seed disc hub clockwise to unlock and remove seed disc.
3. Remove singulator.
4. Install wheat disc wiper in place of singulator.
5. Reinstall seed disc.

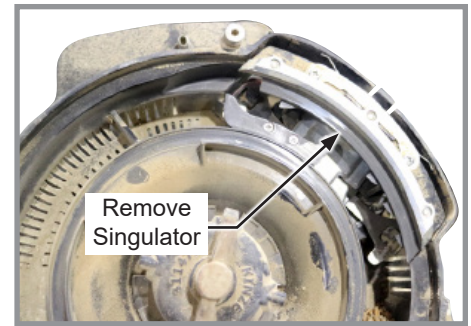

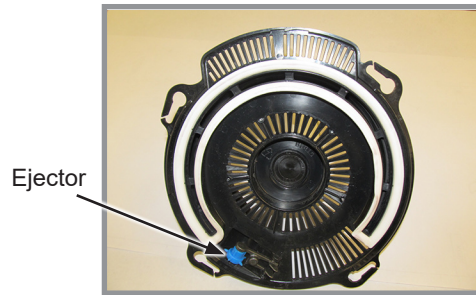

NOTE: Damaged seed or seed containing foreign material will cause plugging of seed disc orifices and require more frequent seed meter cleanout to prevent underplanting.

Wheel-Type Ejectors

Wheel-type ejectors expel seed remnants from seed disc orifices. These ejectors are disc specific and colored coded to match disc.

NOTICE	Replace hopper or tank lids after filling to prevent accumulation of dust or dirt in seed meter resulting in premature wear.
---------------	---

NOTE: Seed size, seed shape, seed treatments, travel speed, and planting rate affect meter performance.

1. Select seed disc and ejector to match crop and population.

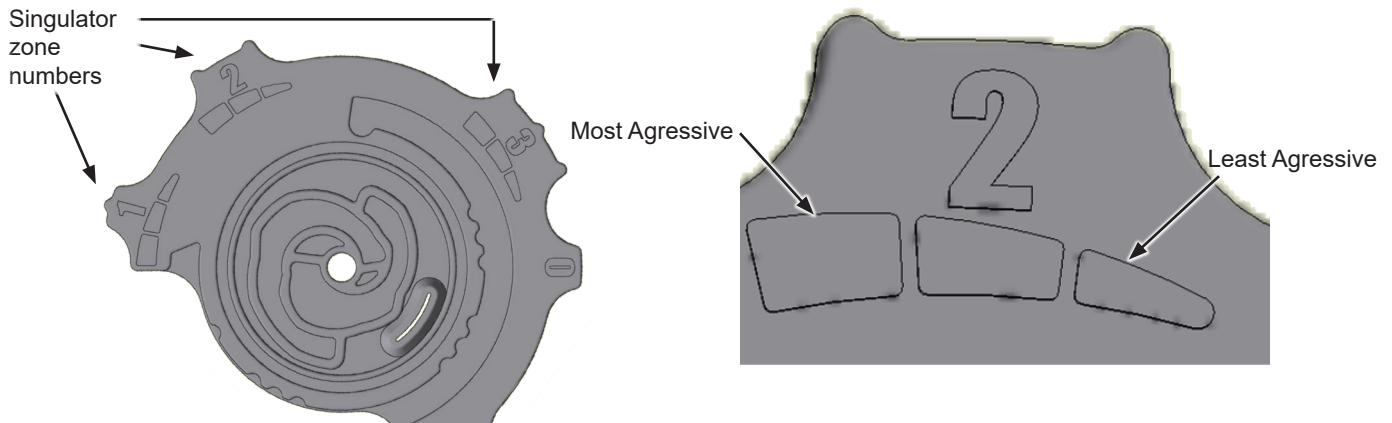

Singulator Adjustment Wheel

2. Adjust singulator wheel to initial setting. Seed size, seed shape, seed treatments, travel speed and planting rate all affect meter performance.
3. With vacuum fan running, lower planter to planting position and drive forward a short distance to load seed into seed disc cells.
4. Adjust vacuum level to initial setting according to tables on page.

NOTE: Vacuum reading will be much lower when seed disc cells are empty. Load all seed cells before setting vacuum level.

NOTE: Operate vacuum fan 3-5 minutes to bring oil up to normal operating temperature prior to making final vacuum level adjustment.

5. Adjust vacuum level to initial setting according to tables on page.

NOTE: Vacuum reading will be much lower when seed disc cells are empty. Load all seed cells before setting vacuum level.

NOTE: Operate vacuum fan 3-5 minutes to bring oil up to normal operating temperature prior to making final vacuum level adjustment.

SEED METER CLEANOUT

NOTE: Use of damaged seed or seed containing foreign material will cause plugging of seed cell orifices and require more frequent seed meter cleanout to prevent underplanting.

Thorough seed meter cleanout is important to maintain genetic purity.

1. Disengage seed drive and remove seed hopper and meter.
2. Dump seed from right rear corner of hopper into a container.
3. Lay hopper on its right side. Push release button and rotate seed meter vacuum cover clockwise to align keyhole slots with bolt heads. Lift off cover.
4. Rotate seed disc hub clockwise to unlock and remove seed disc.
5. Empty meter.
6. Thoroughly inspect meter to ensure all seed is removed.
7. Replace seed disc. Install vacuum cover.

This page left blank intentionally.

ADDITIVES

GRAPHITE

The use of graphite is recommended to promote seed flow, provide lubrication for the seed meter and to help dissipate static charge buildup. Among the available dry seed lubricants graphite is the most effective and easiest to use and it requires no mechanical agitation

CONVENTIONAL HOPPERS

Mix one tablespoon of **powdered graphite** with seed each time hoppers are filled. Regular graphite use prolongs life of the seed meter components, improves seed spacing, and may reduce buildup of seed treatments.

NOTE: DO NOT apply graphite only in center of hopper. It will filter too quickly through the seed and not distribute as evenly as desired.

Apply graphite around outer perimeter of hopper.

BULK FILL TANKS

Mix 1 pound (~0,5 kg) bottle of powdered graphite each time the bulk seed hopper is filled. Graphite should be added in layers as the bulk seed hoppers are filled. Regular graphite use prolongs life of the seed meter components, improves seed spacing, and may reduce buildup of seed treatments.

Lubricant Application Rate	
Graphite	
Conventional Hoppers	1 Tbs. (~15 ml)/Hopper Fill
Bulk Fill Tanks	1 Lb (~0,5 kg) Bottle/Tank
80/20 Talc-Graphite	
Conventional Hoppers	1/2 C (120 ml).**
Bulk Fill Tanks	8 Lbs (~4 kg)/Tank
**Must be evenly mixed during fill.	
Talc	
Conventional Hoppers	1/4" C. (~59 ml*)
Bulk Fill Tanks	4 Lbs (~2 kg)/Tank*
*Double amount of talc for sunflowers.	

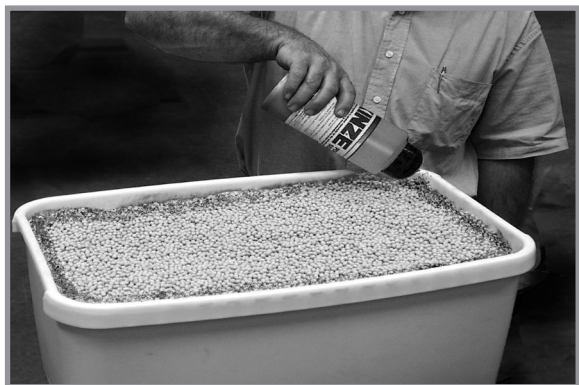

Adding graphite to conventional hopper



Adding graphite to bulk fill hopper

NOTE: Additional graphite may be required to retard buildup of seed treatments on meter components. More frequent cleaning of monitor seed tubes may be necessary due to use of additional graphite.

80/20 TALC-GRAPHITE

Talc-Graphite lubricant is to be used for treated seed, providing benefits of both talc and graphite. It absorbs moisture to prevent bridging, minimizes static electricity for improved seed flow, and lubricates seed and meters.

Conventional Hoppers

Mix ½ C. of 80/20 talc-graphite evenly with seed each time hoppers are filled. Regular graphite use prolongs life of the seed meter components, improves seed spacing, and may reduce buildup of seed treatments.

NOTE: Talc-Graphite lubricant MUST be mixed evenly during fill.

Bulk Fill Hoppers

Mix 8 lbs. of 80/20 talc-graphite each time the bulk seed hopper is filled. Regular graphite use prolongs life of the seed meter components, improves seed spacing, and may reduce buildup of seed treatments.

NOTE: Talc-Graphite lubricant MUST be mixed evenly during fill.

TALC

Talc seed lubricant may be used as a drying agent in addition to graphite lubrication. The drying agent may improve seed release and/or **to retard buildup of seed treatments on meter components.**

1. Fill hopper ½ full of seed, add ¼ cup (conventional); 2 pounds (Bulk Fill) of talc and **mix thoroughly**.
2. Finish filling hopper, add another ¼ cup (conventional); 2 pounds (Bulk Fill) of talc and **mix thoroughly**.
3. Adjust rate of talc use as needed so all seeds are coated, while avoiding a buildup of talc in bottom of hopper.

Humid conditions and/or small sized seeds with extra seed treatment may require additional talc to maintain meter performance.

NOTE: Liquid seed treatments or inoculants may create buildup on the seed disc or brushes. Check frequently for proper population and/or seed delivery when using any liquid seed treatment.

Completely mix all treatments with seed following manufacturers' recommendations. Seed treatment dumped on top of seed after hopper is filled may not mix properly and cause seed bridging, reducing population or stopping meter from planting.

RAPSEED PLANTING SECTION

NOTICE

When used with rapeseed, some seed will be lost through the air dissipator screen. Proper lubrication and quality seed is essential for proper machine operation.

MONITOR SETTINGS

KPM III	
Meter Type:	Vacuum
Meter Sprocket:	28 Tooth
Crop Type:	Other Small Seed
Seeds Per Rev:	83
Seed Size:	1
Interplant:	Enable

See *KPM III Electronic Seed Monitor Operator Manual* for more details.

NOTE Set sensitivity value to 1 for Ag Leader InCommand and Integra monitors. See Monitor Operator manual for more information.

NOTE: Because of small seed size and high seeding populations, it is possible in certain planting conditions that not all seeds will be detected by the row unit seed sensor. So it is possible KPM III and Ag Leader InCommand or Integra monitors might not show correct seeding accuracy. Monitor planting accuracy alarm may be required to be adjusted to lower accuracy (or muted) due to false accuracy alarms. Frequent field checks are recommended.

VACUUM SETTINGS

Due to rapeseed size and weight variations planting settings may vary. Testing with a Kinze T4000 test stand is recommended to verify vacuum level setting and to achieve best planting accuracy. See your Kinze dealer for testing.

Set desired vacuum to value found during testing (recommended) or use preliminary values provided in chart below.

If testing is unavailable measure 20 - 50 seed samples and find average seed diameter (largest - width/length/height seed dimension).

Target Speed (km/h)	Target Population	Target Vacuum (inches (cm) of water)		
		Small Seed Diameter Range: 1,2 - 2,0 mm (Average: 1,6 mm)	Medium Seed Diameter Range: 1,5-2,5 mm (Average: 2,0 mm)	Large Seed Diameter Range: 1,6-3,1 mm (Average: 2,6 mm)
8	350000	4 (10)	4 (10)	6 (15)
8	500000	4 (10)	6 (15)	8 (20)
8	650000	4 (10)	8 (20)	12 (30)
8	800000	4 (10)	12 (30)	16 (40)
10	350000	4 (10)	6 (15)	8 (20)
10	500000	4 (10)	8 (20)	12 (30)
10	650000	4 (10)	10 (25)	14 (35)
10	800000	6 (15)	12 (30)	16 (40)

ADDITIVES

Rapeseed

It is essential to use graphite to neutralize electrostatic rapeseed properties.

Mix rapeseed with Kinze graphite thoroughly in a closed container. Keep mixing until all seed becomes evenly coated. Excessive graphite will stay on the bottom of container. It is recommended to prepare an even amount of seed-graphite mix for each hopper separately. This will help to monitor each row performance while planting.

Use approximately 1Tbs (~15ml) of graphite per 3-4 l of seed.

NOTE: For best performance Kinze brand graphite MUST be used.



RATE CHARTS

For Rapeseed Rate Charts, See [“General Planting Rate Information” on page 5-1](#) section of this manual.

VACUUM METER INSULATION FOR RAPESEED

Additional insulating shims for Vacuum Meters are needed in order to successfully and efficiently plant rapeseed with Blue Drive equipped machines, as they prevent the seeds from getting crushed, thus clogging up the seed disc. The shims are obligatory on Blue Drive planters, but provide a tangible benefit when used on Ground Contact Drive planters as well. The instructions below detail the process of shim insertion and removal, as well as washing of seed discs.

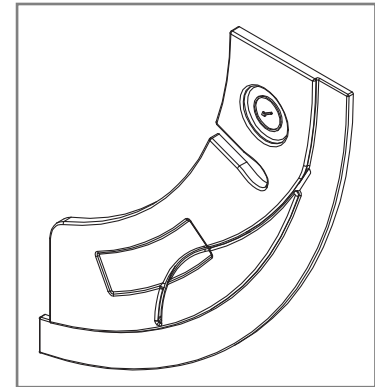

Rapeseed Meter Insulation Shim

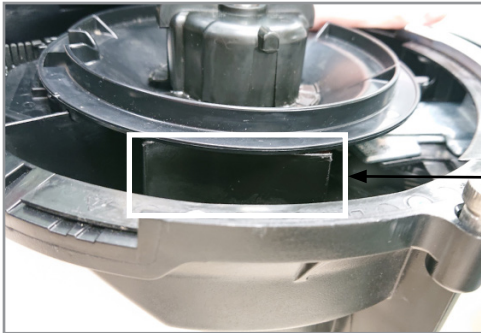

Place of the Shim on the Baffle

Inserting the Insulation Shim:

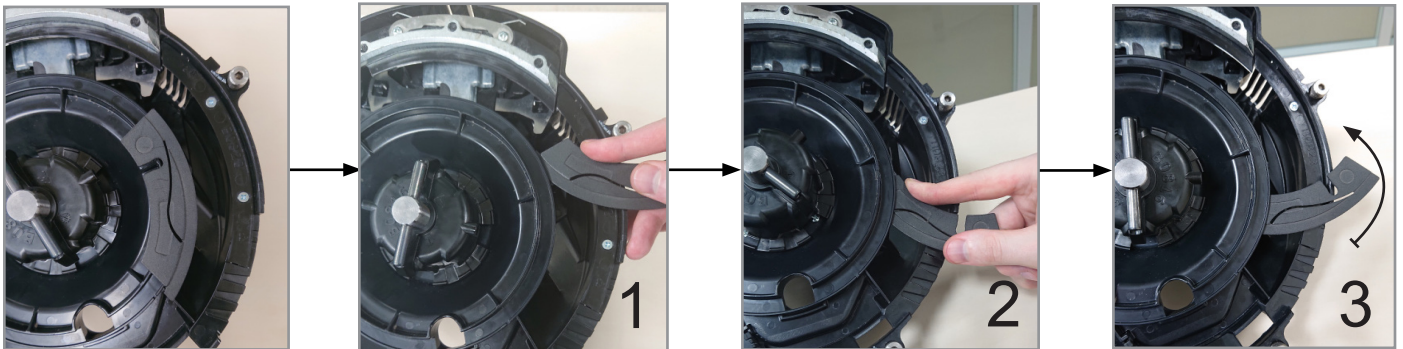

1. Begin inserting the Insulation Shim by sliding the tail end of it inside the gap indicated above, knife-like (img. 1).
2. Once initially inserted in the gap, rotate the Shim to the left by about 90° (img. 2 & 3).
3. Proceed to apply continual pressure while also maintaining the desired direction with your fingers until the shim is securely inserted (the longitudinal contoured gap in the shim is aligned with the contour of the baffle of the vacuum meter on which it sits, the shim clicks into place)(img. 4, 5 & 6).

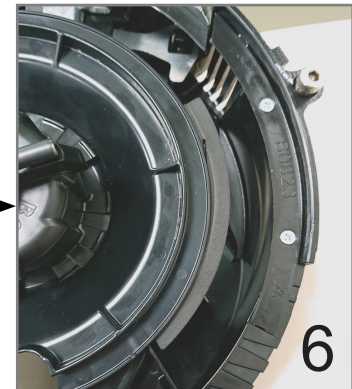

Removing the Insulation Shim:

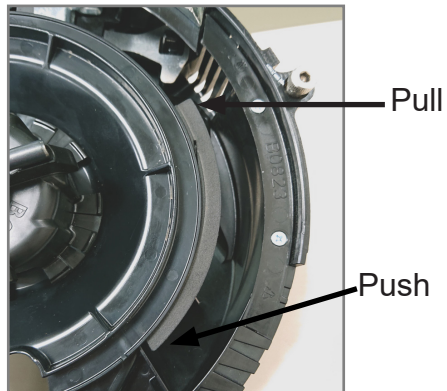

To remove the Insulation Shim, push down with your fingers on one end, while pulling on another end (see img. above).

Washing Seed Discs:

When planting Rapeseed, Seed Discs will periodically need to be scrubbed and washed with soap and water to remove the accumulated oils and debris, which prevent the disc from functioning optimally. Maintaining clean discs will ensure the best planting results.



ROW UNIT MOUNTED RESIDUE WHEEL

Row unit mounted residue wheels are used on pull and push row units.

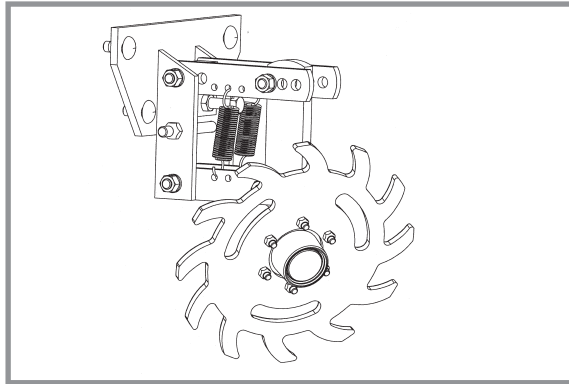

Row Unit Mounted Residue Wheel

Two adjustable springs on each residue wheel parallel links provide down force adjustment. Position 1 provides minimum down pressure and position 3 maximum down pressure.

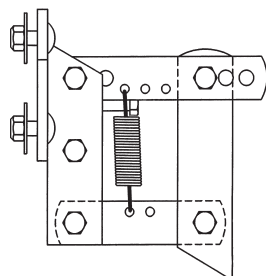

Position 1 (Least)

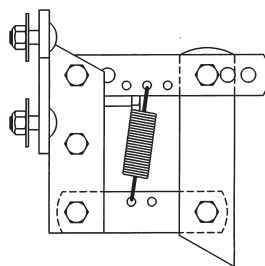

Position 2

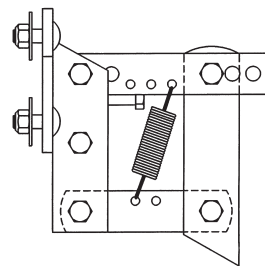

Position 3 (Most)

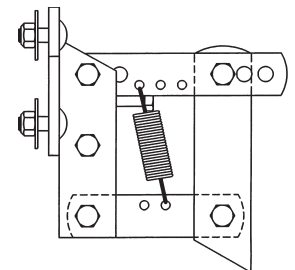

Additional uplift or float

Raise row unit and reposition springs to adjust down pressure.

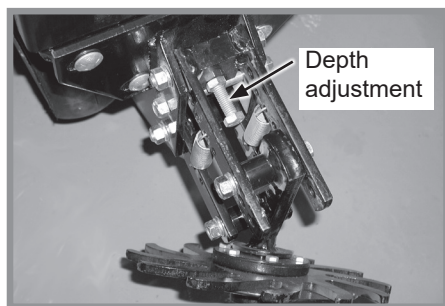

Wheel depth adjustment

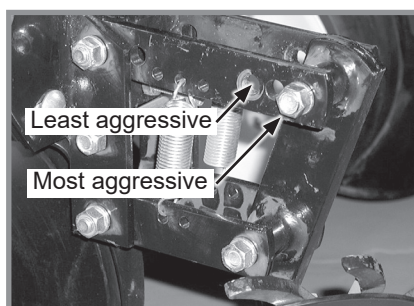

Wheel angle adjustment

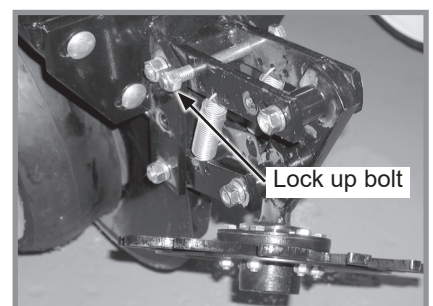

Wheel lock up

A full threaded bolt and jam nut located on the upper link sets maximum depth for loose soil conditions. Initial setting is 45 mm above row unit double disc opener depth.

Three holes in upper link adjust wheel angle. With wheel mount in most vertical position, using the rear hole in the upper link, the residue wheel is most aggressive. Moving wheel mount to a forward hole reduces aggressiveness of residue wheel for use in mulch till applications where soil is loose.

To lock residue wheel up, remove 1/2" x 5" lockup bolt, raise residue wheel and install bolt.

ROW UNIT MOUNTED NO TILL COULTER

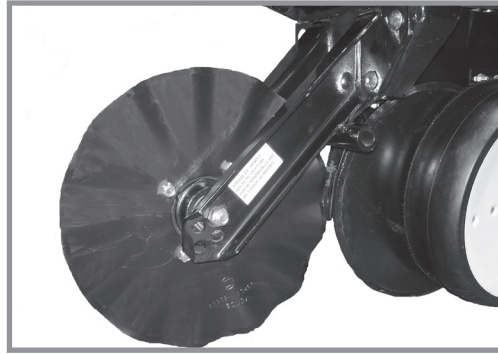

Row unit mounted no till coulters with 1" bubbled, 1" fluted (8 flutes) or ¾" fluted (13 flutes) blades may be used on pull row units and push row units (¾" fluted shown). Four quick adjustable down force springs are required per row when using row unit mounted no till coulters. See "Quick Adjustable Down Force Springs Options".

Align coulters blade in relation to row unit double disc openers. Adjust by loosening four attaching bolts, moving coulters arm, and tightening four attaching bolts. Coulters blade can be adjusted to one of four ½" incremental settings in the forked arm. Initial location is the top hole. Move blade as it wears to one of the three lower hole to maintain coulters blade at or slightly above opener discs as needed. Adjust coulters below depth of double disc opener blades in very hard soil conditions such as compacted wheel tracks to improve opener penetration and cutting of surface residue.

Check operating depth by setting planter down on a level concrete floor and checking relationship between coulters blade and row unit opener blade. Make sure planter is level and coulters is square with planter frame and aligned with row unit disc opener.

NOTE: Torque ⅝" spindle hardware to 120 ft-lb (~163 Nm).

COULTER MOUNTED RESIDUE WHEELS

Coulters mounted residue wheels are designed for use on pull row units and push row units. Row unit extension brackets are required on the four center pull row units if the planter is equipped with coulters mounted residue wheels.

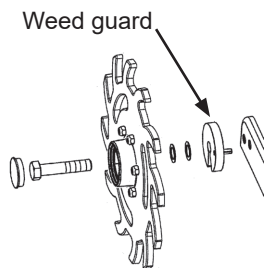

NOTE: Opening in weed guard must face down.



Residue wheels attach to row unit mounted coulters with two cap screws and sleeves allowing unit to free-float. A 2-position spindle bolt mounting positions wheels interlocked or staggered. Depth adjustment is made with a spring-loaded cam and pin with 11 positions in ¼" (~6 mm) increments. A high point on the cam allows wheels to be locked up.

A weed guard on the inboard side of each wheel helps prevent weed wrap which can cause premature bearing failure.

GRANULAR CHEMICAL HOPPER AND DRIVE

WARNING

Agricultural chemicals can cause death or serious injury to persons, animals, and plants or seriously damage soil, equipment, or property. Read and follow all chemical and equipment manufacturers labels and instructions.



The granular chemical hopper has a 1.4 cubic feet (~0,04 m³) capacity.

Make sure no foreign objects get into hopper when it is being filled. Replace hopper lids after filling to prevent accumulation of dirt and moisture.

A metering gate on bottom of hopper regulates the application rate. See "Dry Insecticide and Dry Herbicide Application Rate Charts" in this manual. Calibrate using chemical manufacturers' instructions.



Granular chemical hopper

Granular chemical clutch drive coupler and meter shaft can be disengaged and engaged by turning throwout knob at rear of hopper support panel.

Rotate knob ¼ turn counterclockwise to disengage and ¼ turn clockwise to engage.

Slotted holes in hopper support panel and clutch housing allow for alignment adjustment between clutch drive coupler and meter shaft.

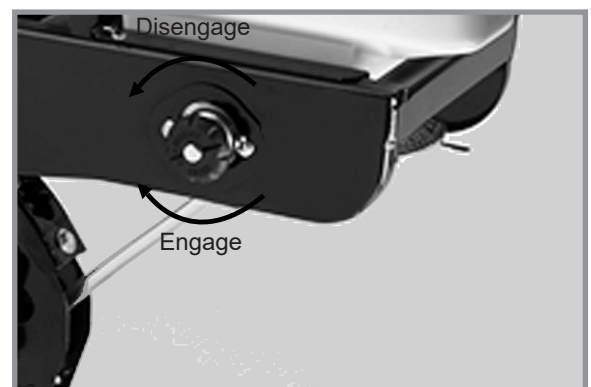

Granular chemical drive release

GRANULAR CHEMICAL BANDING OPTIONS

Granular chemical banding options allow 4½" (~12 cm) slope-compensating banding or straight drop in-furrow placement.

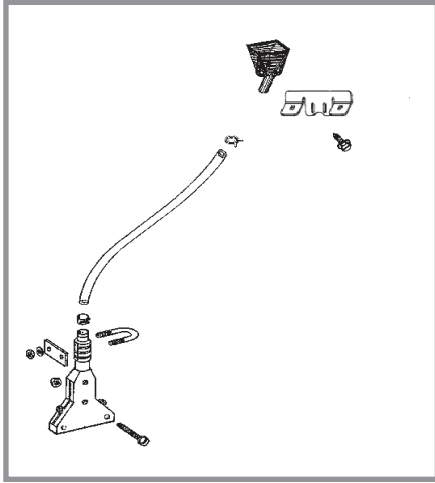

4½" (~11 cm) Slope-Compensating Bander

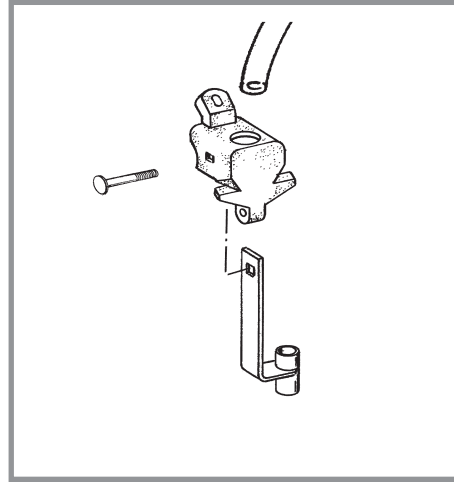

Straight Drop In-Furrow Placement

GRANULAR CHEMICAL BANDER SHIELD

Optional granular chemical bander shield is installed on underside of wheel arm stop to shield crop residue from lodging in granular chemical bander.

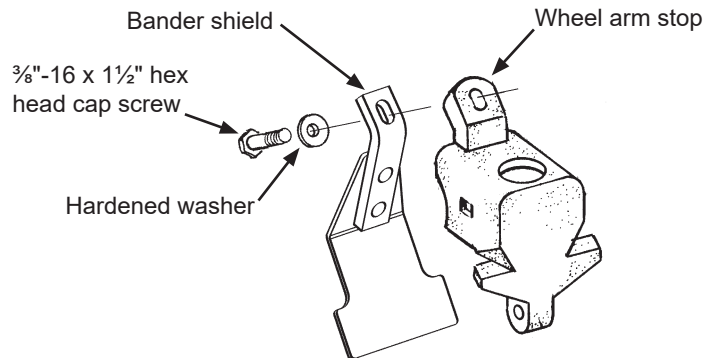

Granular chemical bander shield installation

SPIKED CLOSING WHEEL

Spiked closing wheels crumble the sidewall, allowing roots to penetrate soil. They can be used on pull row units and push row units.

Align spiked closing wheels straight across from each other, in most rearward holes on closing wheel arm. Set the wheels 1" - 1¼" (~2,5 - 3,1 cm) apart at the closest point. If large amounts of contouring is being done, mount wheels in the forward most hole. This will reduce drifting of row unit.

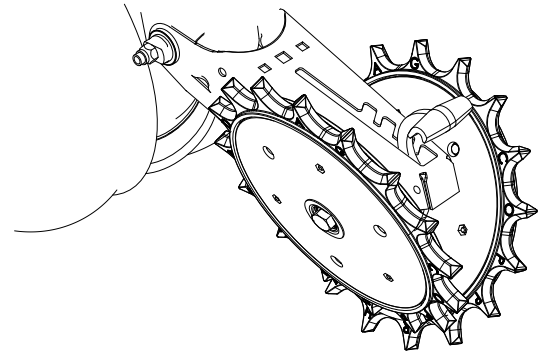

Row Unit Spiked Closing Wheel

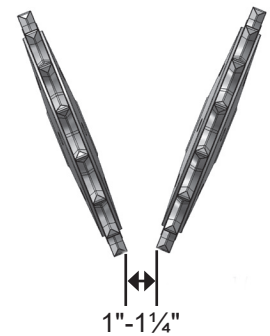

SYSTEM OVERVIEW

Fertilizer can be controlled through the Blue Vantage Display on Blue Drive equipped units. You can increase or decrease fertilizer rate, turn fertilizer function on or off, and load a prescription. Refer to your Blue Vantage manual for more information, if applicable.

NOTCHED SINGLE DISC OPENERS

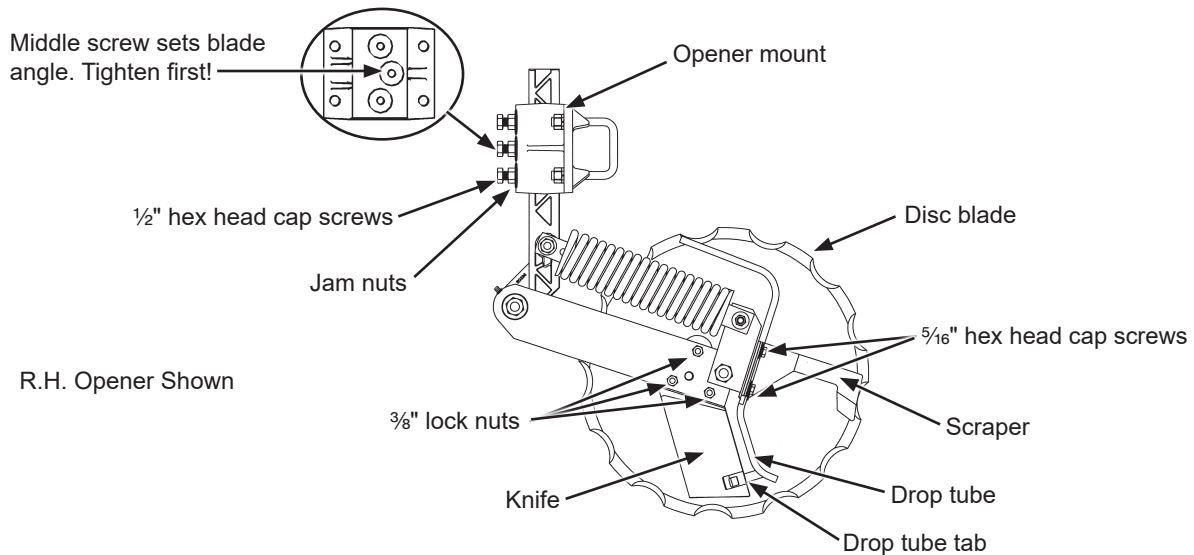

Notched single disc opener adjustments



CAUTION

Compressed spring may fly out of this assembly if attempting to disassemble and cause injury. Do not take apart this assembly.

Disc blades are sharp and can cut causing serious injury. Wear gloves when working on or turning disc blades by hand.



NOTICE

Never strike knife with heavy object. Damage to knife will occur.

If knife to disc blade clearance is too large, soil or residue can wedge between knife and blade, and blade will not turn.

1. Adjust knife to disc blade contact. Loosen or tighten $\frac{3}{8}$ " lock nuts to adjust knife's entire leading edge against disc blade. Turn blade and check for slight resistance without freewheeling. Readjust knife to blade's tight spot as needed.

NOTICE

Adjust liquid drop tube out of path of soil flow across knife. Drop tube and tab wear quickly if not correctly adjusted.

2. Adjust scraper and drop tube. Loosen two $\frac{5}{16}$ " hex head cap screws. Adjust scraper until just touching disc blade. Adjust drop tube until it is centered between knife and disc blade. Tighten screws. Turn blade and check for slight resistance without freewheeling. Repeat as needed. Insert flat bladed pry bar or screwdriver between knife and drop tube above drop tube tab. Carefully bend tube until $\frac{1}{4}$ "- $\frac{3}{8}$ " (~6 - 10 mm) from disc blade.

NOTE: Maximum disc blade depth 4" (~10 cm).

3. Adjust blade depth. Loosen three $\frac{1}{2}$ " hex head cap screws and jam nuts in opener mount. Adjust opener assembly up or down to desired blade depth. Tighten center hex head cap screw and jam nut first to set proper disc blade angle. Tighten remaining hex head cap screws and jam nuts. Torque hex head cap screws and jam nuts to 57 ft-lb (~77 Nm). Check fertilizer hose clearance and adjust as necessary.

DEPTH/GAUGE WHEEL ATTACHMENT FOR NOTCHED SINGLE DISC FERTILIZER

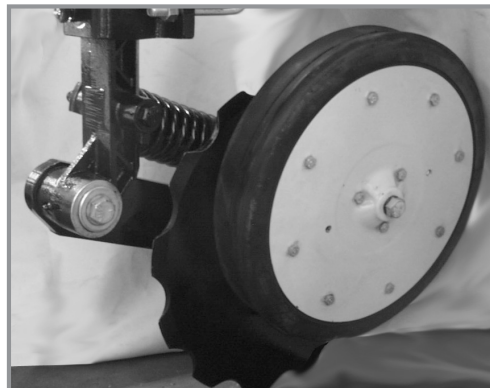

Notched single disc opener depth/gauge wheel

Depth/gauge wheel attachment for notched single disc fertilizer opener is used where additional gauging is required to maintain desired fertilizer opener depth. Depth/gauge wheel is attached to notched single disc fertilizer opener using a mounting block fastened to the pivot arm with $\frac{5}{8}$ " hardware through disc blade bearing.

Depth adjustment is made using 3 adjustment holes in depth/gauge wheel mounting block. Moving depth/gauge wheel increases/decreases depth in approximate 1" (2.5 cm) increments in relation to blade depth setting made at vertical mounting post.

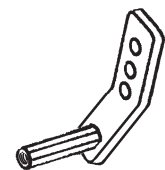

HD SINGLE DISC FERTILIZER OPENER

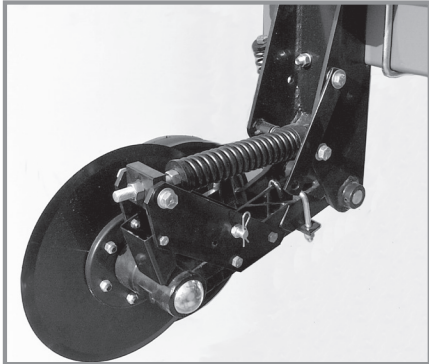

HD single disc opener

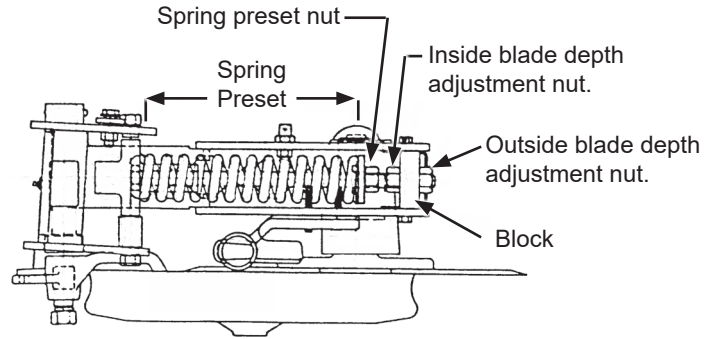

R.H. configuration shown (Overhead view)

Recommended placement of fertilizer with HD single disc fertilizer opener is 3½" - 4" (8.8 - 10.1 cm) from row.

NOTICE	Never place fertilizer closer than 2" (5 cm) to row or seeds may be damaged.
---------------	---

Maximum blade depth is approximately 5" (12.7 cm) with planter frame level and at 20" (50.8 cm) operating height. Soil conditions can affect depth slightly.

Raise planter to remove weight from fertilizer opener. Loosen inside adjustment nut with 1½" wrench. Turn outside nut clockwise to decrease or counterclockwise to increase blade depth. One full turn of blade depth adjustment nut changes blade depth ⅜". Tighten inside nut tight against block. Adjust all fertilizer openers to same depth.

Fertilizer opener down pressure can be adjusted from 250 lb (113.4 kg) to 640 lb (290.3 kg).

NOTICE	Do not operate HD single disc fertilizer openers at full down pressure tension on rocky ground or disc blades will chip.
---------------	---

NOTE: DO NOT adjust spring preset dimension less than 9½" (24.13 cm).

NOTE: Excessive down pressure can cause planter frame up-lift and affect machine performance. Planter frame should be 20" (50.8 cm) from ground in planting position. Excessive down pressure in loose soil conditions can cause openers to run too deep and push dirt ahead of opener and may stop soil press wheel and opener blade from turning.

Raise planter to remove weight from fertilizer opener. Turn spring preset nut clockwise to increase and counterclockwise to decrease down pressure. Adjust all rows to a similar setting. Minimal spring pressure for acceptable operation is recommended. See chart for spring length setting specifications.

Adjust spring loaded dry fertilizer drop tube/scrapper periodically to maintain ⅛" (3 mm) gap between drop tube and opener blade. If this dimension is not maintained fertilizer may not drop in proper location.

Loosen scraper adjustment bolt. Slotted hole in scraper allows up or down adjustment.

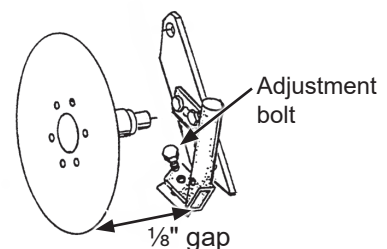

Spring Preset	
Length	Down Pressure
11" (27.9 cm)	250 lb (113.4 kg)
10¾" (27.3 cm)	320 lb (145.1 kg)
*10½" (26.7 cm)	370 lb (167.8 kg)
10¼" (26 cm)	450 lb (204.1 kg)
10" (25.4 cm)	520 lb (235.8 kg)
9¾" (24.8 cm)	580 lb (263.1 kg)
9½" (24.1 cm)	640 lb (290.3 kg)
*Initial setting	

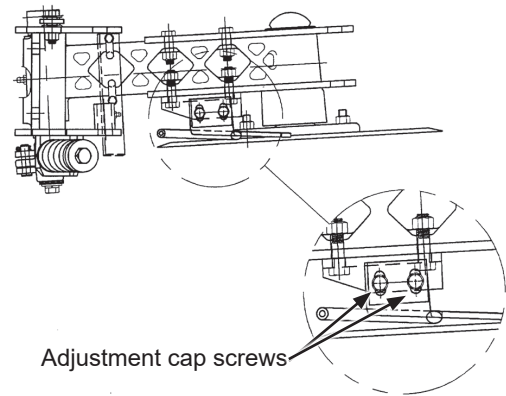

Adjust liquid drop tube/scrapper so there is slight contact between blade and scraper lower leading edge, and $\frac{1}{4}$ " (0.6 cm) clearance between liquid drop tube trailing edge and blade. Blade should turn with minimum amount of drag.



DRY FERTILIZER ATTACHMENT

 <p>WARNING</p>	<p>Agricultural chemicals can cause death or serious injury to persons, animals, and plants or seriously damage soil, equipment, or property. Read and follow all chemical and equipment manufacturers labels and instructions.</p>
	

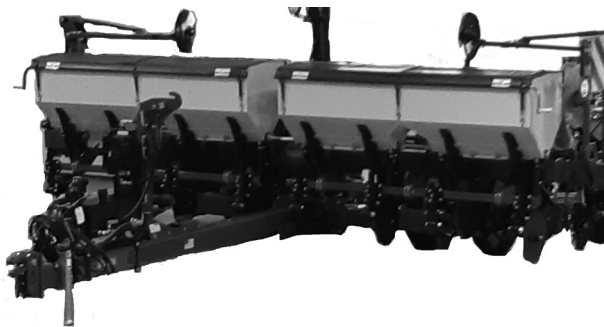

Dry fertilizer option installed

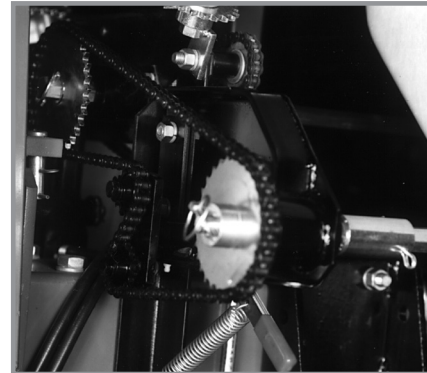

Fertilizer drive rate transmission

Rate of fertilizer application is determined by drive/driven sprocket combination on fertilizer drive rate transmission and auger position in the hoppers.



Augers positioned for high rate delivery

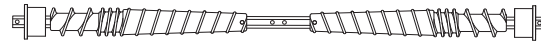

Augers positioned for low rate delivery

NOTE: Uneven delivery of fertilizer will occur if high rate auger position is used at too low a rate setting.

Remove 1/4" (~0,6 cm) stainless steel cap screws holding augers in place on shaft and reposition augers to change delivery rate.

A fertilizer transmission is located directly ahead of row unit transmission on right side of planter and allows simple, rapid changes in sprockets to obtain desired fertilizer application rates. Chain tension is controlled by a spring loaded idler adjusted with a ratchet arm located to inside of transmission. Sprockets can be changed with those on the sprocket storage rod by removing hexagon shaft pins. Fertilizer rate charts in Rate Chart section will help you select correct sprocket combinations.

NOTE: Make a field check after each sprocket combination adjustment to be sure you are applying fertilizer at desired rate.

<p>NOTICE</p>	<p>Placing fertilizer too close to seeds or in excessive amounts can cause germination or seedling damage. Check with your fertilizer dealer or manufacturer for correct amount and placement.</p>
----------------------	--

Because dry fertilizer attachment meters granules by volume rather than weight, differences in brands, and fertilizer analysis, weight metered during actual application may vary considerably. Use chart for reference only. Use a container to catch and measure application for a better estimate.

Keep fertilizer dry during use and storage since most fertilizers easily absorb moisture. In addition to waste, deposits of fertilizer left in hopper can cause metal corrosion. Empty hoppers at end of each day.

CLEANING

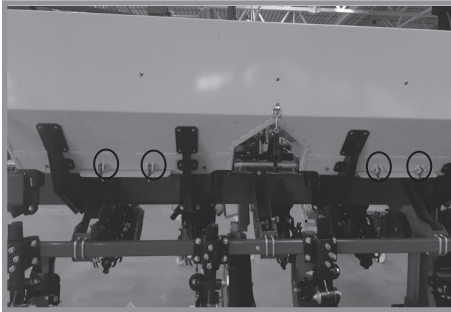

Unbolt screws under the Fertilizer hopper

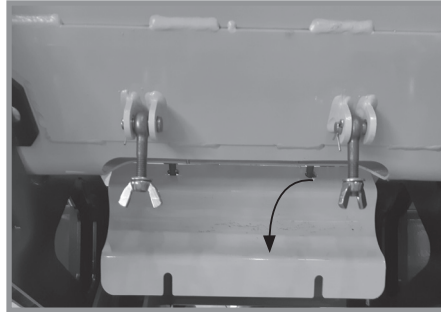

Open the Fertilizer cleaning doors



Cleanout Chute installed

Dry fertilizer hoppers are easy to clean. Unbolt screws under the hoppers and open Fertilizer cleaning doors. Use cleanout chute.

At end of planting season or when fertilizer attachment is not used for a period of time, hoppers should be disassembled, cleaned, and metal surfaces coated with a rust preventative. Remove $\frac{1}{4}$ " cotter pin and bearing from one end of shaft. Pull auger assembly from opposite end of hopper. Remove stainless steel cap screws from auger shaft and remove all auger components for cleaning. Coat all parts with rust preventative before reassembly. Reinstall auger halves in low or high rate position.

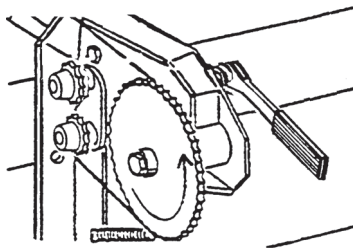

Transmission direction of rotation

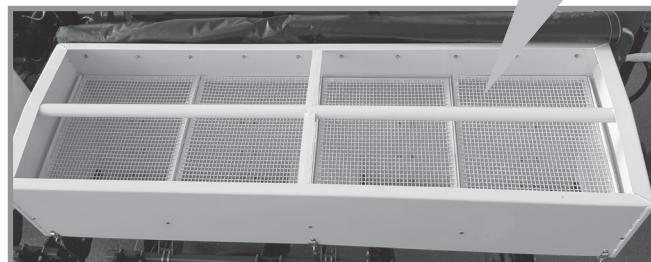

Auger installation

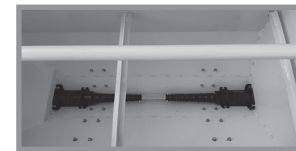

Flighting must move chemicals from center to outside of hopper.

NOTE: Install auger assembly so the flighting moves material to outer openings in hopper when augers rotate in direction they turn during operation.

Slide auger assembly through outlet housing into hopper. Secure in place by reinstalling bearing and cotter pin. Rotating shaft in direction shown to see if flighting (spirals) on auger move toward ends of hopper. If not, remove auger assembly, turn 180° , and reinstall.

NOTE: Frequent lubrication of auger bearings is critical to ensure augers turn freely. Check "[Lubrication and Maintenance](#)" on page 6-1. Be certain augers turn freely. If not, loosen $\frac{5}{16}$ " carriage bolts in outlet housings, rotate auger several times, and retighten carriage bolts. This allows housings and augers to realign.

NOTE: Do not operate fertilizer attachment without auger baffles in place.

Install auger baffles over augers and secure in place with two hair pin clips in each hopper.

LIQUID FERTILIZER ATTACHMENT

WARNING



Agricultural chemicals can cause death or serious injury to persons, animals, and plants or seriously damage soil, equipment, or property. Read and follow all chemical and equipment manufacturers labels and instructions.

CAUTION

Overfilling tank can cause siphoning, tank collapse, personal injury, and damage to property and equipment. Do not overfill tank. Do not leave planter unattended when filling tank. Close fill valve and open tank lid if siphoning occurs. Follow all chemical manufacturers first aid, cleanup, and handling instructions.



Liquid fertilizer option installed



Check valve

NOTE: Optional low rate check valves are available for in-line installation between liquid fertilizer squeeze or piston pump and openers to ensure equal distribution of product at low rates. Check valves also eliminate anti-siphon loops.

NOTICE

Placing fertilizer too close to seeds or in excessive amounts can cause germination or seedling damage. Check with your fertilizer dealer or manufacturer for correct amount and placement.

OPTIONAL PISTON PUMP

NOTE: Keep manuals shipped with pump and flow divider with this manual.

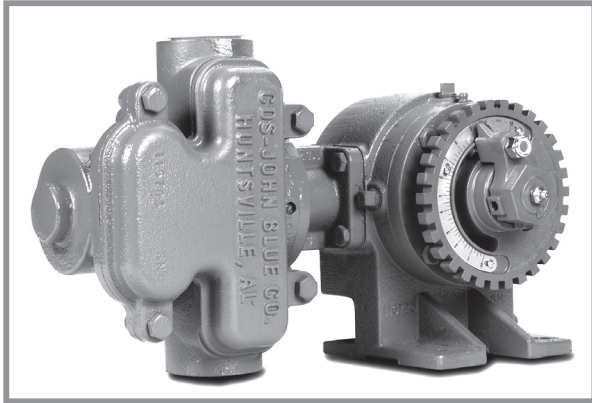

Piston pump

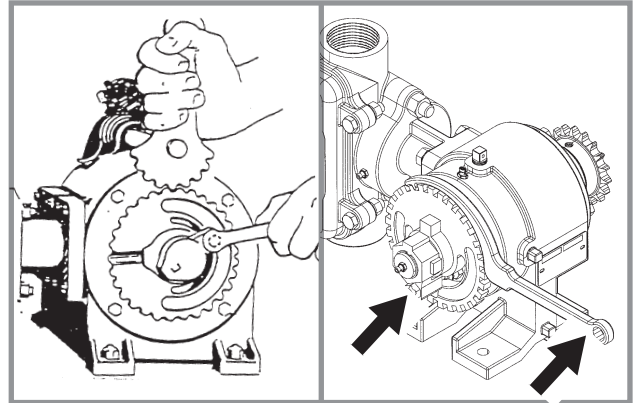

Adjusting delivery rate

NOTE: Delivery rate chart in Rate Chart section of this manual provides approximate application rate only see ["Liquid Fertilizer Piston Pump Application Rates" on page 5-13](#) Delivery varies with temperature and fertilizer.

Loosen $\frac{3}{8}$ " lock nut that secures arm with pointer and rotate scale flange with adjustment wrench until pointer is over desired scale setting. Tighten $\frac{3}{8}$ " lock nut. DO NOT OVERTIGHTEN.

NOTE: Periodically check flow to all rows. Set rate is delivered to remaining rows if one or more lines are plugged.

Cleaning

Clean tanks, hoses, and metering pump thoroughly with water at end of planting season or prior to an extended period of non-use. Do not allow fertilizer to crystallize from cold temperature or evaporation.

On machines equipped with piston pump, take apart and clean strainer located between piston pump and ball valve daily. Remove the end cap to clean the screen. See ["Piston Pump Storage" on page 6-29](#).

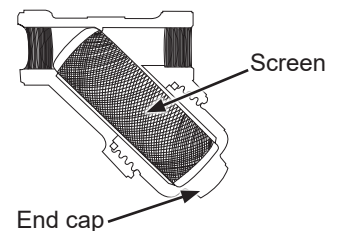

Blue Vantage Liquid Fertilizer

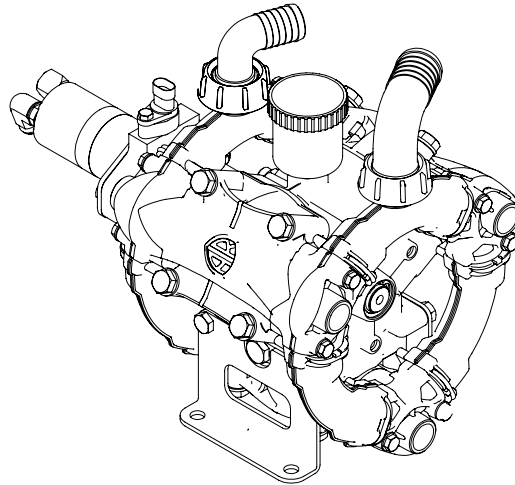

CAUTION

DO NOT use the diaphragm pump without first checking that the intake and delivery circuit pipelines are correctly secured and free from leaks.

DO NOT draw in liquids at temperatures above 50°C and below 5°C.

DO NOT use the pump for flammable, toxic or corrosive liquids or liquids with unsuitable density, especially solvents or residue of any kind.



CAUTION

Before doing any maintenance work, depressurize the liquid system and isolate the pump from all energy sources.

When the jobs are done, before restarting the pump, check that no tools, rags or other materials have been left close to moving parts or in hazardous zones.

NOTICE

Before start-up, the operator must perform the necessary safety checks.

In the event of leaks from the pressurized pipes, stop the pump at once and fix the leak.

NOTICE



During the first few hours of operation, check that the oil level in the tank remains between the minimum and maximum limits. If top-ups are required, use oil specified in the Maintenance section of the manual.

Fertilizer Systems Parts Overview

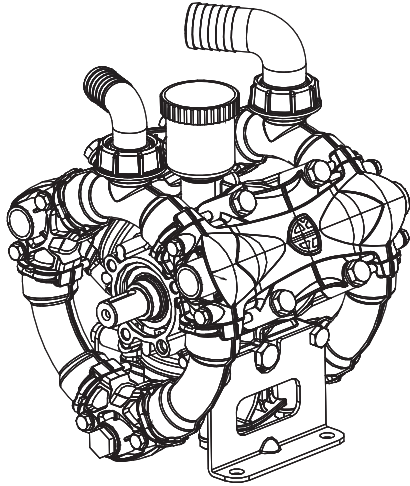
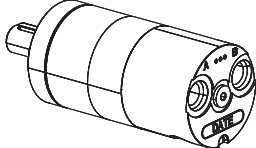
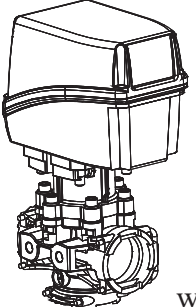
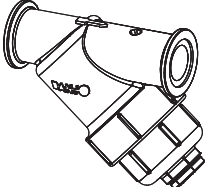
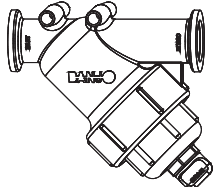
NOTE: See parts manual for part numbers.

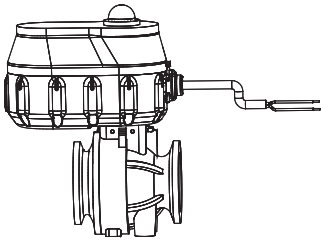
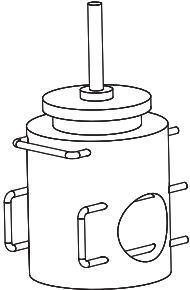
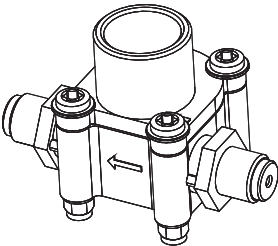
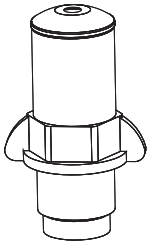
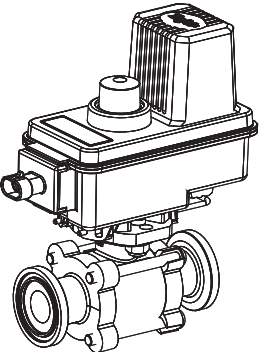
COMPONENT		DESCRIPTION
Diaphragm Pump	 <p style="text-align: center;">3 Cylinder</p>	<p>Oil Capacity: 1 L</p> <p>Diaphragm Kit: Available, see parts manual. Check Valve Kit: Available, see parts manual. Seal Kit: Available, see parts manual. Oil: Available, see parts manual. Winterizer: Available, see parts manual.</p>
Hydraulic Motor		<p>Fertilizer Pump Motor. Small pump and large pump have different motors.</p> <p>Seal Kit: Available, see parts manual.</p>
Pressure Regulator	 <p style="text-align: right;">W</p>	<p>Controls delivery manifold pressure and bypasses overhead flow for agitation.</p>
Suction Strainer		<p>30 mesh.</p> <p>Clean regularly.</p>
Pressure Strainer		<p>80 mesh.</p> <p>Clean regularly.</p>

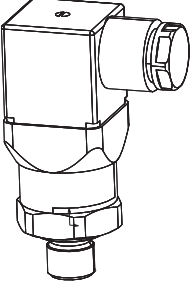
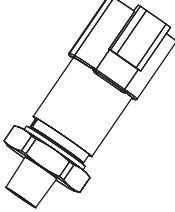
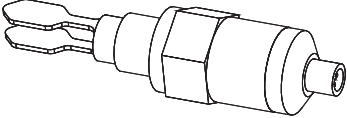
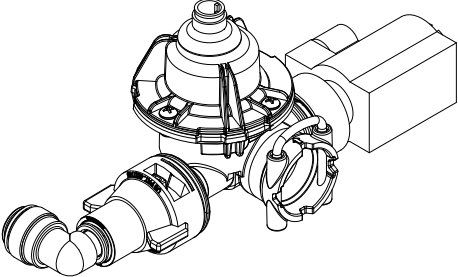
COMPONENT		DESCRIPTION
Suction Ball Valve		ON/OFF valve that opens flow of fertilizer to the pump. This feature is used when entering planting task in Blue Vantage.
Large System Flow Meter		Full flow flow meter.
Small System Flow Meter		Arrows on housing indicates direction of flow.
		Small flow meter sensor.
Small Ball Valve		Closes to send flow through small flowmeter at low flow rates.

COMPONENT		DESCRIPTION
Suction Sensor		<p>Located in suction strainer. Sends pump suction pressure to Blue Vantage controls.</p>
Pressure Sensor		<p>Sends delivery manifold pressure to Blue Vantage controls.</p>
Fluid Switch		<p>Located in tank for low level alert. Located in suction circuit to know when pump has fluid supply.</p>
Row Flow Meter		<p>Indicates flow or no flow to each row.</p>
Jet Orifice		<p>Used for all orifices smaller than .055 and not used for .065 and larger.</p>
4916 Orifice		<p>Different orifices used for different application rates.</p>

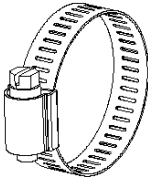
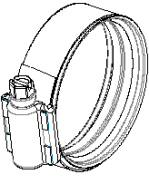
Hose Clamp Torque Values Chart				
 Standard	 Heavy Duty	Diameter	Standard	Heavy Duty
		1¼"	42 in-lb	75 in-lb
		1½"	42 in-lb	75 in-lb
		2"	42 in-lb	X

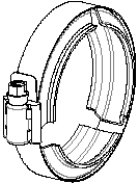
Flange Clamp Torque Values Chart		
	Diameter	Torque
	1"	50-60 in-lb
	2"	90-100 in-lb

LIQUID FERTILIZER SYSTEM SCHEMATICS

Fertilizer is controlled through the Blue Vantage display. You can increase or decrease fertilizer rate, turn fertilizer function on or off, and load a prescription. Refer to your Blue Vantage manual for more information.

Rear Trailer or Hitch Auxiliary Tank

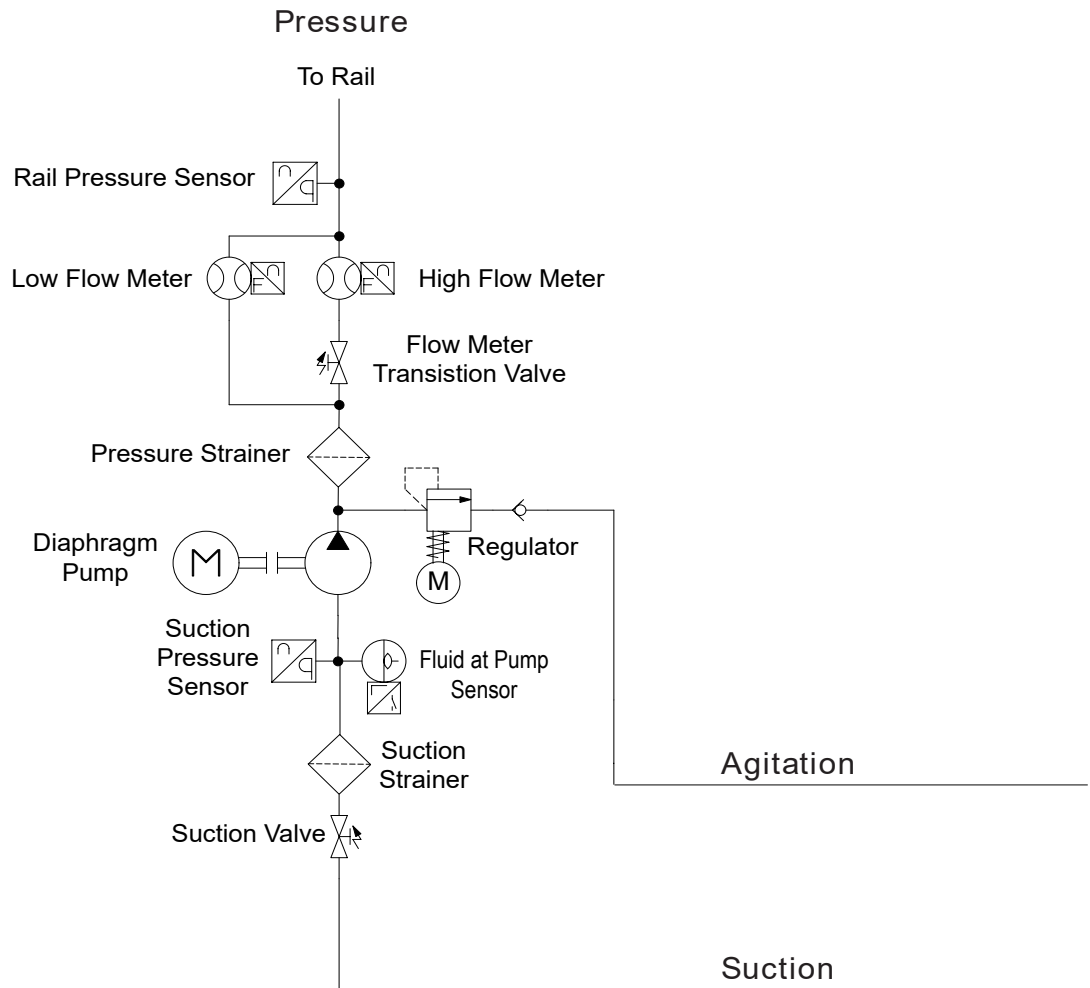

System Overview

Diaphragm Pump - Model Number AR120

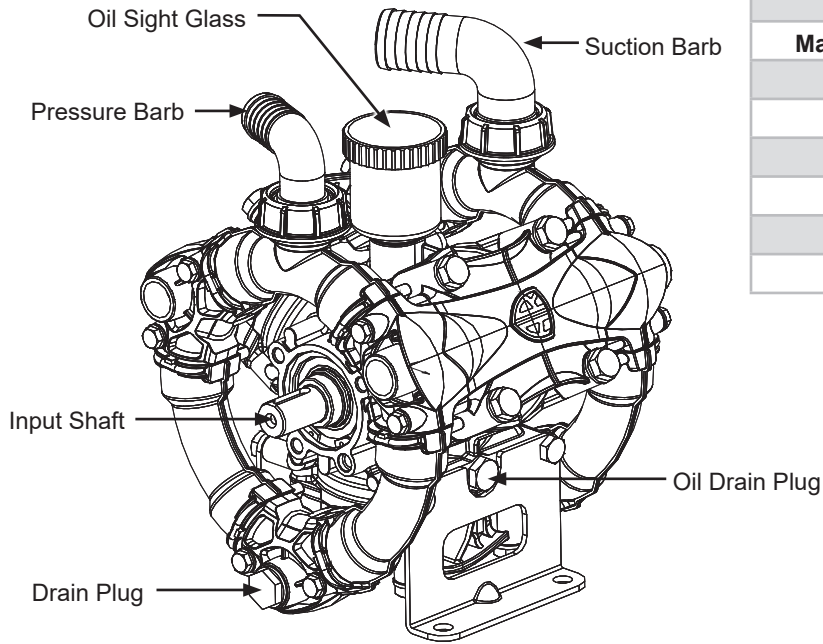

Operating Pressure Range	
	AR120
Max GPM (Max L/min)	30.8 (116.6)
Max PSI (Max kPa)	220 (1517)
Weight	15.4 kg
Cylinders	3
Oil Capacity	1 L
Max Speed (RPM)	550
Pulsation Damper	No

Diaphragm pumps are reciprocating positive displacement pumps. Reciprocating movement of the diaphragms expands and compresses volumes. This mechanical work and change in volumes cause transfer of liquid. The main difference between a diaphragm pump and other types of reciprocating pumps, is the presence of a flexible separating component (the diaphragm) between mechanical parts and pumped liquid circuit. This enables diaphragm pumps to transfer liquids which would be detrimental to other types of reciprocating pumps. Pistons are generally in a “Boxer” type opposing cylinder arrangement, or in a radial layout around the axis of the crankshaft which drives them.

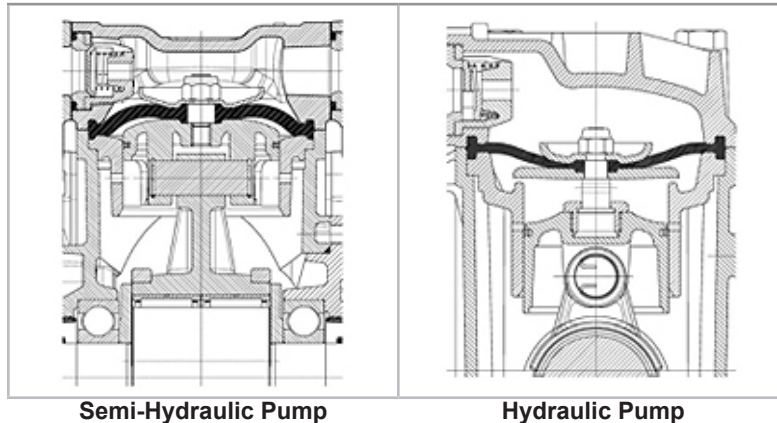

The piston is mechanically connected to diaphragm. The diaphragm is mechanically operated by piston at it's center and at the same time it's outer edge ensure a watertight seal around the pumping chamber. In a “semi-hydraulic diaphragm pump”, the diaphragm is rigidly secured to piston by a stud screwed on the piston and a plate tightened by a nut. In a “Hydraulic diaphragm pump” the center of the diaphragm is fixed to a floating component on piston. The suction and delivery valves, fitted at the pumping chamber suction and delivery ports, are operated by the alternating negative and positive pressure inside circuit.

Suction

During the suction stroke (piston retreating), the difference between the suction pressure and the pressure inside the pump head open the suction valve and closes the delivery valve. The transferred liquid is drawn into the head by the suction line.

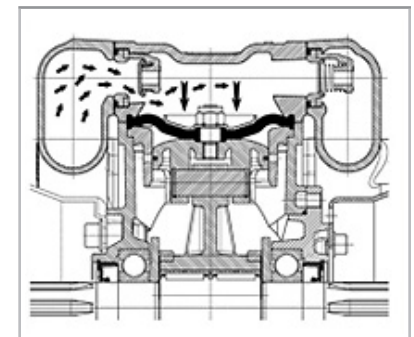

Suction

Compression

During the compression stroke (advancing piston), the suction valve closes and the delivery valve opens due the pressure generated inside the head by the piston. The transferred liquid is pumped out of the head and into the delivery line.

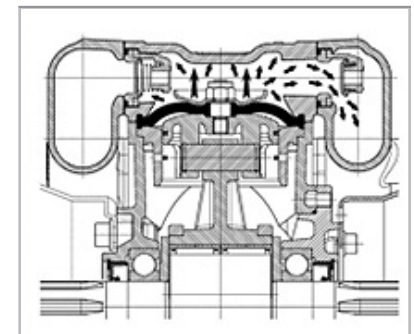

Compression

Oil

When pump is new, oil in tank is clear and yellowish in color. After a few operating hours, the oil in tank loses its transparency and becomes dark due to metal particles removed by rubbing of internal components during functioning. This is normal color for this type of diaphragm pump. This occurs regardless of the type of oil used and pump's working conditions. In heavy-duty working conditions, oil will become dark more quickly. When oil in the tank becomes light grey and looks milky (color also depends on color of the liquid being pumped), stop using the pump immediately, it is likely that one or more diaphragms have ruptured, allowing the aqueous solution pumped to pass into the lubricating oil and form a water/oil emulsion inside pump body.



Oil in New Pump



Oil in Functioning Pump



Oil After Diaphragm Rupture

Replacing Diaphragms

Aside from its lubricating function, in diaphragm pumps the oil passes through the calibrated holes in the sleeves uncovered at every piston stroke to form a protective cushion between piston and diaphragm. The volume of this oil cushion is not constant; it varies with pressure/vacuum inside pumping chamber. However, the oil cushion is only effective when it does not contain residual air. After replacing diaphragms the oil cushion should be restored, by removing as much air as possible inside the body and specifically between pistons and diaphragms

Restore oil cushion:

1. Calibrated holes in the sleeves must always be mounted in vertical position, allowing air to flow out, and cap must be off tank.
2. Before proceeding weigh quantity of oil stated in manual for the specific pump model.
3. Turn pump shaft by hand and tilt at various angles; air bubbles will be seen coming out of tank.
4. When the entire amount of oil specified for the pump has been poured in, oil is between the minimum and maximum level marks on the tank and no air is bubbling out. The system has been vented correctly.

NOTE: Particularly heavy or bulky pumps can be operated at low RPM for a few minutes at 0 bar without oil cap on oil sight reservoir. Air bubbles will come out, causing level to drop. Top up until entire quantity of oil specified for the pump has been added.

NOTE: During operation, if working pressure increases, the level in tank will increase, if pump is working with a high suction pressure (obstructed filter, suction from a strong gradient), level in tank will reduce.

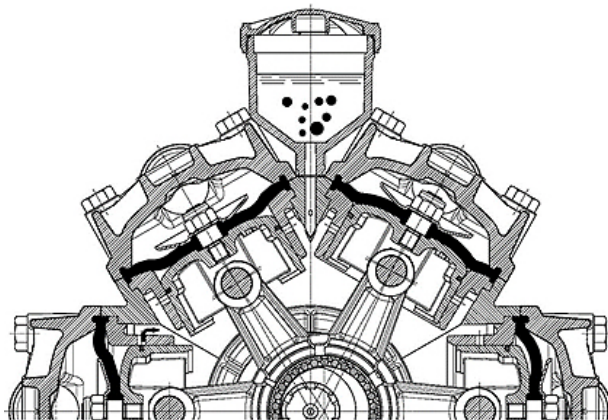

Improper Fertilizer Pump Operation

- Do not use the pump in a potentially explosive atmosphere.
- Do not use the pump for flammable, or liquids with unsuitable density, especially seawater, adhesives, bitumens, asphalt sealers, two-step curing compounds, concrete sealers, liquefied gases or solvents of any kind, paints of any kind or liquids containing solids in suspension.
- Do not draw in liquids at temperatures above 122°F (50°C) or below 41°F (5°C).
- Do not use the pump in drinking water supply systems.
- Do not use the pump on products for human consumption.
- Do not use the pump without first checking that the intake and delivery circuit pipelines are correctly secured and free from leaks.
- Do not use the pump without the safety devices provided: guards for shafts and drive couplings and suitably rated relief valve on the delivery circuit.
- Do not use the pump to wash or spray: people, animals or delicate items, live electrical equipment or chemicals whose characteristics are not known.

Servicing Pump

Refer to the parts manual for all service kit part numbers. Use the chart below for maintenance intervals.

MAINTENANCE INTERVAL	ACTION
Each time used.	Check level and status of oil.
	Check suction filter and clean if necessary.
Every 50 hours.	Check pulsation damper inflation pressure (if applicable).
	Check if suction line is intact.
	Check if pump is tightly fastened to chassis of machine. NOTE: Should the pump not be securely fastened, DO NOT use the machine for any reason.
Every 300 hours.	Check the diaphragms and replace if necessary. Replace all diaphragms in the pump, regardless of conditions if aggressive chemicals are used.
	Check damper diaphragm (if applicable) and replace if necessary.
	Replace oil. Oil MUST be changed every time diaphragms are replaced. First oil change must be made after 300 hours.
	Check to be sure pump screws are tight. If pump operates in conditions of heavy vibration, check more frequently.

Checking Oil Level

- Check oil with pump level, ensuring that it has been running for at least 5 minutes in normal working conditions.
- If oil level is not visible or completely full, add or remove oil to restore this level and check, still with the pump running, that the oil level does not vary so much that it leaks from the cap or is no longer visible in tank.
- If necessary, **top up with SAE 30 compressor oil.**
- Check oil level regularly, as it may vary significantly with operating conditions.



Topping Up

To top up with oil proceed as described below:

1. Unscrew the cap (B) on the oil sight glass and pour in oil until the level is between the minimum and maximum values indicated (A).
2. Screw the cap (B) back on.

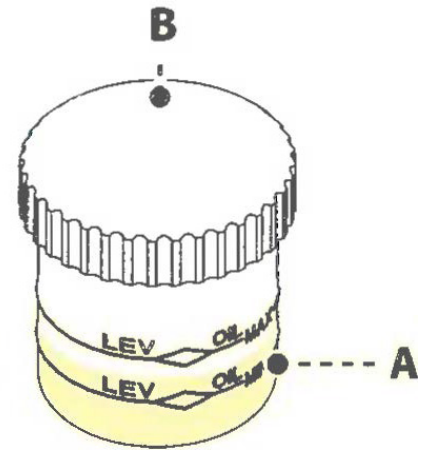
Changing the Oil

To change the oil in the pump, proceed as described below:

1. Loosen the cap on the oil sight glass.
2. Unscrew the oil plug located on the pump casing (C). Use container of an adequate size to drain about a liter of oil from the pump.
3. Let the oil pour out of the pump. Dispose of oil in accordance with local regulations.
4. Refill the pump with about 1 liter of oil using the purge button on the Blue Vantage to spin the pump and get all oil circulated. When oil level stops going down it is adequate.
5. Reinstall the oil drain plug.
6. Reinstall the cap.

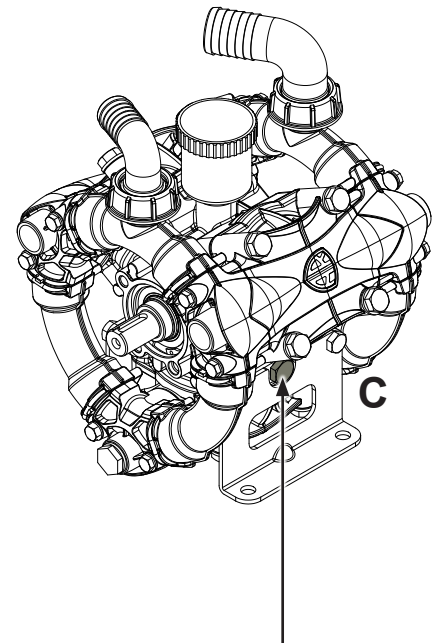

Remove plug to drain oil

Oil change intervals & conditions

Every 300 hours of use	Change oil
Grey or milky oil color	Change oil

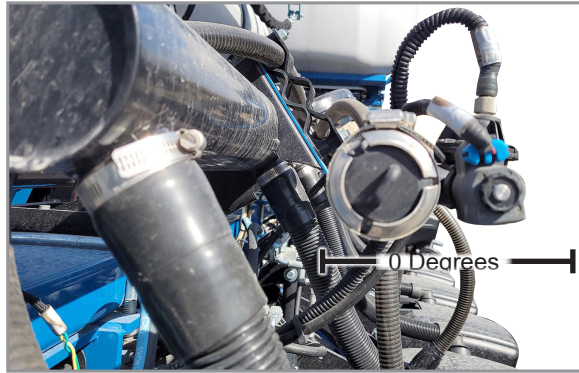
ROW FLOW METER**End View**

When planter toolbar is on level ground, check to ensure all flow meter are also as horizontal as possible for best operation. If flow meter is not level while planter is on level ground, adjust by rotating manifold(s).

ROW FLOW METER CLEANOUT

Fertilizer can salt out when certain conditions of time and temperature are met. This causes a buildup of fertilizer granules in and around areas of low flow. This will cause errors in the performance of the fertilizer flow manifold.

To properly clean, disassemble the entire assembly. Use the illustrations below as a guide for disassembly and reassembly.

Clean all parts thoroughly with clean water at the end of planting season or prior to an extended period of non-use. Do not allow fertilizer to crystallize from cold temperatures or evaporation.

1. Turn cover counterclockwise to unlock and remove cover from flow meter.

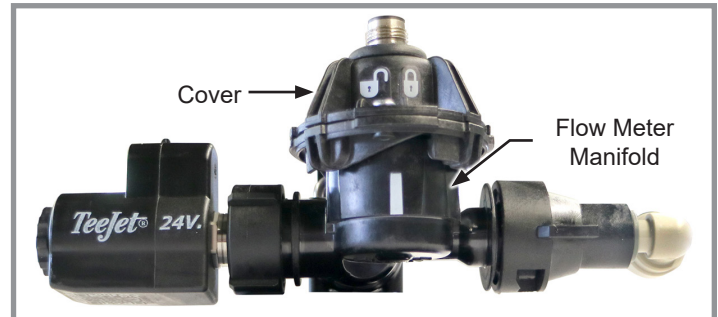

2. Remove paddle wheel from cavity.
3. Clean all parts thoroughly with clean water. Remove any debris inside of cavity.

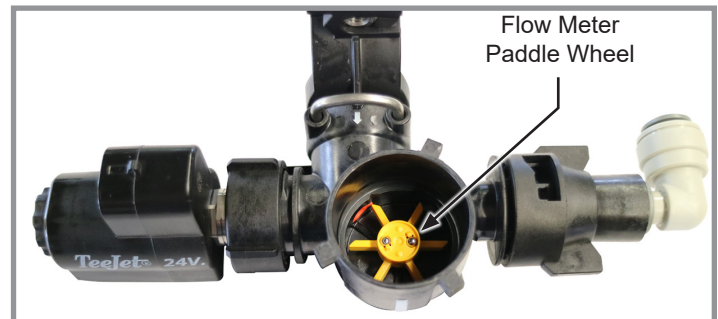

4. Once clean, place paddle wheel back onto pin inside cavity and spin the paddle wheel to ensure it is seated correctly.



5. Reinstall cover and turn clockwise until the "lock symbol" is directly above the white line.

NOTE: If cover does not go on easily, paddle wheel is not aligned correctly on pin.

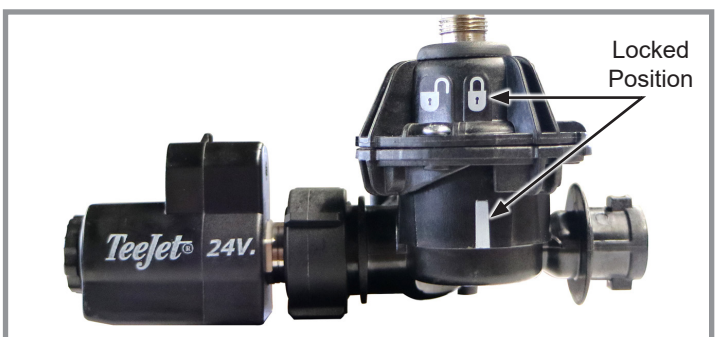

ROW FLOW METER JET ORIFICE REMOVAL

1. Turn cover counterclockwise to unlock and remove cover from flow meter.

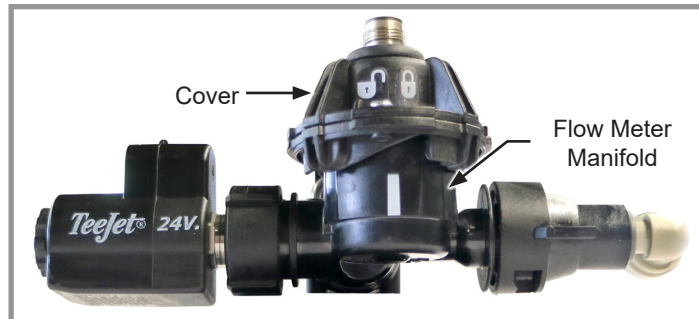

2. Remove paddle wheel from cavity.

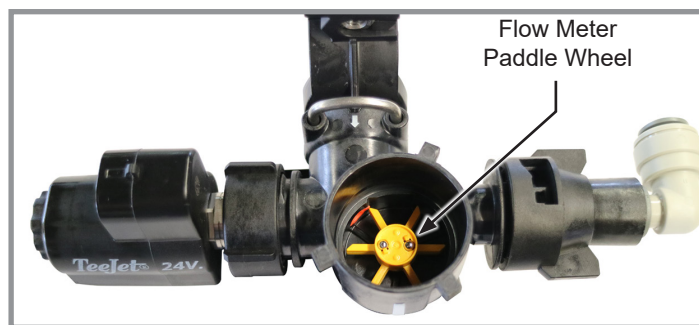

3. Rotate the nozzle assembly counterclockwise 90° and pull nozzle off.
4. Pull strainer out of flow meter.
5. Remove row shutoff valve by spinning nut counterclockwise and pulling valve out.

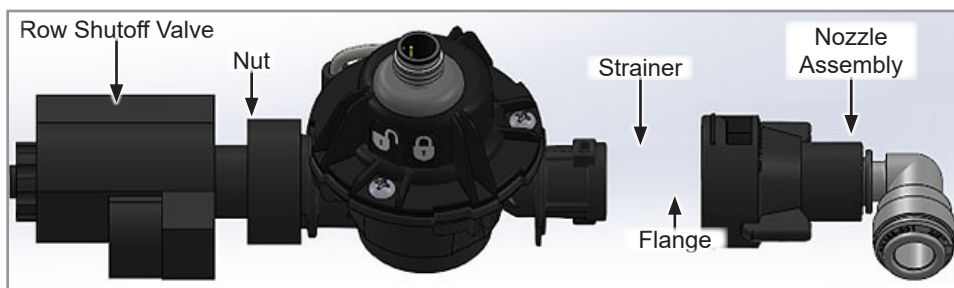

6. Remove jet orifice:

- Insert #1 Phillips screwdriver from the nozzle assembly side until the tip is in the jet orifice as shown. Then push the jet orifice out.

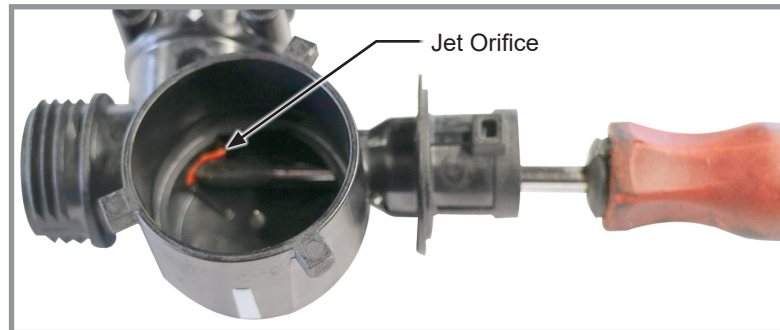

7. Reassemble flow meter

- Reinstall row shutoff valve and tighten nut clockwise.
- Place the paddle wheel on the pin in the cavity and spin paddle wheel to ensure it is seated correctly.
- Reinstall cover and turn clockwise until the lock symbol is directly above the white line.
- Reinstall strainer.
- Reinstall gasket, orifice, and nozzle assembly.

ROW FLOW METER JET ORIFICE INSTALLATION

1. Remove row shutoff valve by spinning nut counterclockwise and pulling valve out.
2. Turn cover counterclockwise to unlock and remove cover from flow meter

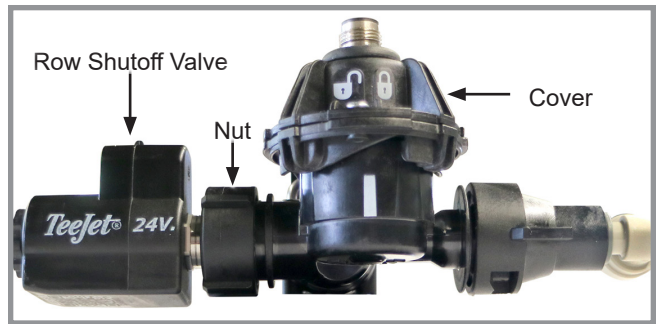

3. Place jet orifice on the end of #1 Phillips screwdriver, with the long tip closest to the rail and pointing toward the paddle wheel cavity.

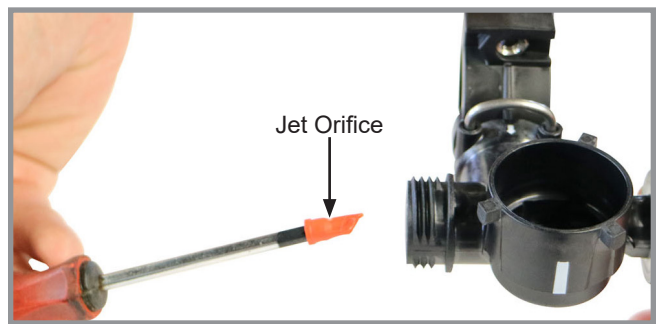

4. Insert jet orifice into center hole on the row shut valves, gently twisting back and forth to help align the rib on the orifice and the groove in the housing. The jet orifice should be flush with paddle wheel cavity wall when installed completely.

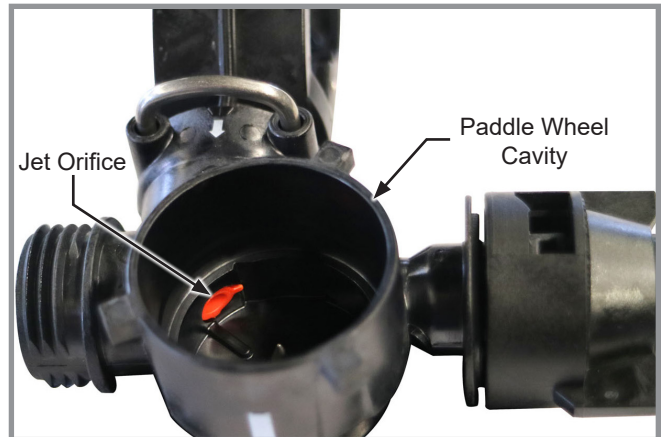

5. Reinstall row shutoff valve and tighten nut clockwise.
6. Place paddle wheel on the pin in the cavity and spin the paddle wheel to ensure it is seated correctly.

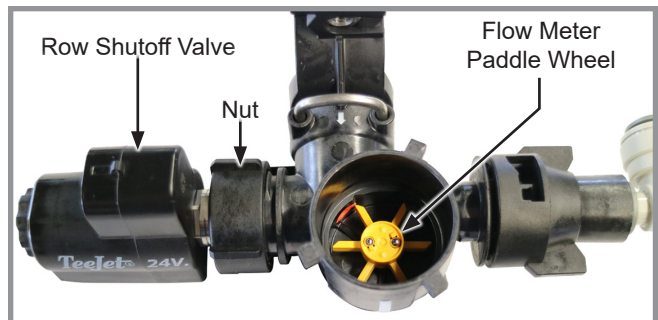

- Reinstall cover and turn clockwise until the lock symbol is directly above the white line.

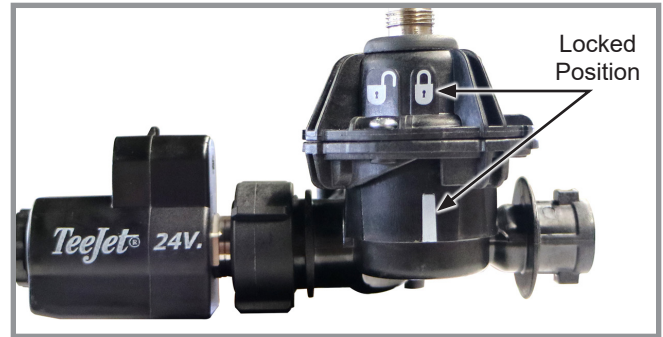

- Reinstall strainer.

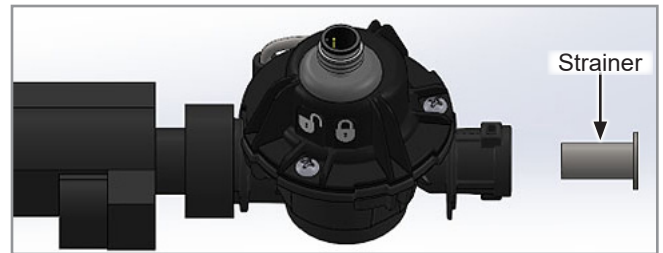

- Reinstall gasket, orifice, and nozzle assembly.

NOTE: Orifices must be installed correctly. Install orifice with the blank side towards the flow meter manifold and the stamped side facing nozzle assembly (pointing downstream toward the direction of delivery).

NOTE: Orifice is installed in center groove of gasket.

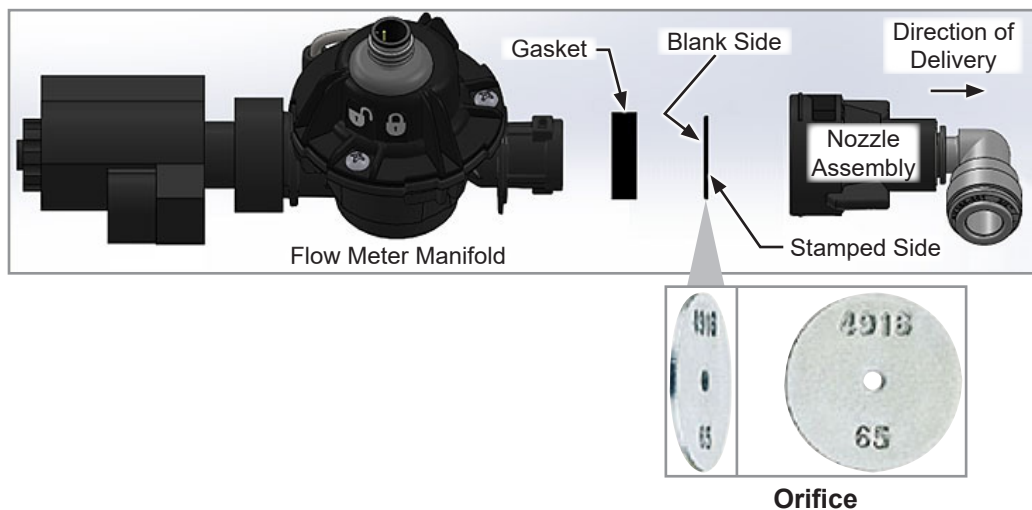

FLOW METER STRAINER AND ORIFICE CLEANING AND/OR REPLACEMENT

Strainer

1. Rotate the nozzle assembly counterclockwise 90° and pull nozzle off.

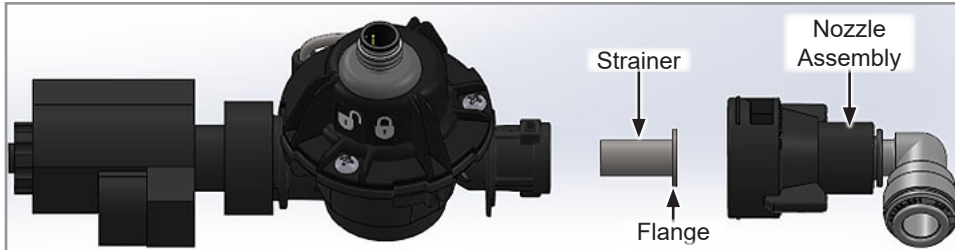

2. Pull strainer out of flow meter and clean or replace it.

NOTE: Reinstall a clean strainer with the flange towards the nozzle cap. Refer to table to ensure the correct strainer is chosen for the orifice selected.

Orifice Size	Strainer Mesh Size	Part Number	Color
0.015 and Below	200	G10943201	Pink
0.016 - 0.039	100	G10943101	Green
0.040-0.070	50	GD27290	Blue
0.072 and Larger	---	---	---

NOTE: If the rail pressure increases during planting, clean the strainers.

Orifice

1. Rotate the nozzle assembly counterclockwise 90° and pull nozzle off.

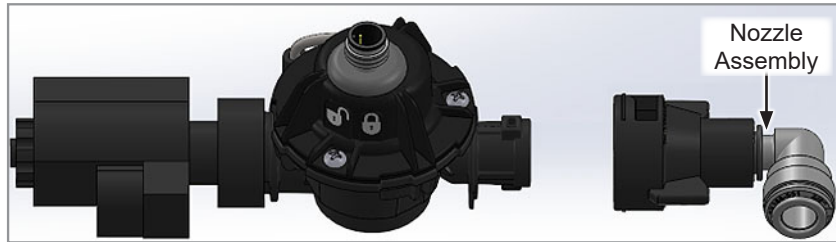

2. Remove gasket with orifice currently installed.
3. Remove orifice from gasket.

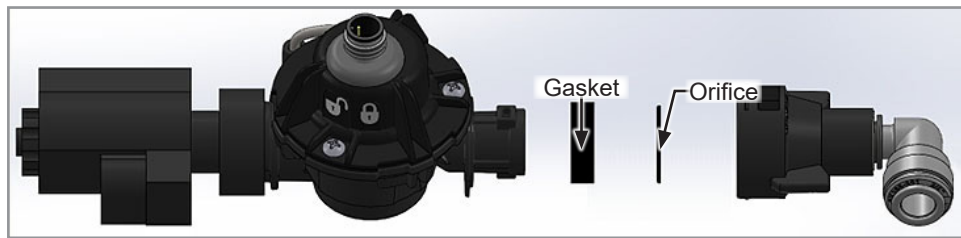

NOTE: Orifices must be installed correctly. Install orifice with the blank side towards the flow meter manifold and the stamped side facing nozzle assembly (pointing downstream toward the direction of delivery).

NOTE: Orifice is installed in center groove of gasket.

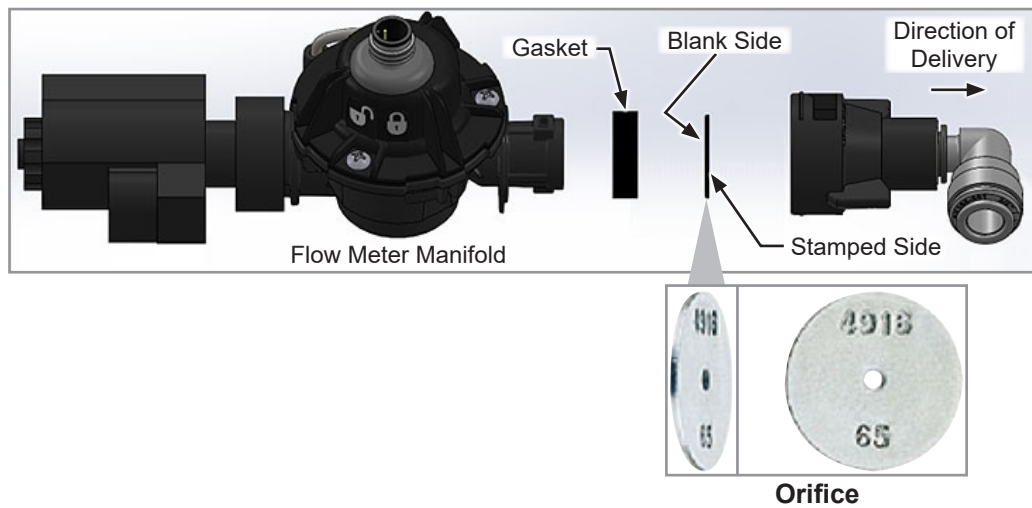

ORIFICE CONFIGURATION RATES

How to select an orifice configuration (using Orifice Look Up Chart below):

- Find the closest listed Liters per hectare [L/ha] value and its group of rows.

Identify the slowest and highest planting speed that will be used. Follow those rows over to corresponding row spacing being used, this equals Liters per minute [L/min].

- For a more accurate L/min value, use this formula: $L/min = \frac{(Row\ Spacing\ (cm) \times km/h \times L/ha)}{60000}$

- Take the low and high L/min values, trace them vertically on Orifice Rate Chart. Whichever bar best covers that range, this is the configuration that should be used.

NOTE: If the L/min value is high enough, the jet orifice may have to be removed, see "Row Flow Meter Jet Orifice Removal" on page 4-23.

ORIFICE LOOK UP CHART

L/ha	km/h	70cm L/min	35cm L/min	L/ha	km/h	70cm L/min	35cm L/min	L/ha	km/h	70cm L/min	35cm L/min	L/ha	km/h	70cm L/min	35cm L/min	L/ha	km/h	70cm L/min	35cm L/min
8	6	0.06	0.03	30	6	0.21	0.11	70	6	0.49	0.25	140	6	0.98	0.49	220	6	1.54	0.77
8	9	0.08	0.04	30	9	0.32	0.16	70	9	0.74	0.37	140	9	1.47	0.74	220	9	2.31	1.16
8	13	0.12	0.06	30	13	0.46	0.23	70	13	1.06	0.53	140	13	2.12	1.06	220	13	3.34	1.67
8	16	0.15	0.07	30	16	0.56	0.28	70	16	1.31	0.65	140	16	2.61	1.31	220	16	4.11	2.05
8	19	0.18	0.09	30	19	0.67	0.33	70	19	1.55	0.78	140	19	3.10	1.55	220	19	4.88	2.44
10	6	0.07	0.04	40	6	0.28	0.14	80	6	0.56	0.28	160	6	1.12	0.56				
10	9	0.11	0.05	40	9	0.42	0.21	80	9	0.84	0.42	160	9	1.68	0.84				
10	13	0.15	0.08	40	13	0.61	0.30	80	13	1.21	0.61	160	13	2.43	1.21				
10	16	0.19	0.09	40	16	0.75	0.37	80	16	1.49	0.75	160	16	2.99	1.49				
10	19	0.22	0.11	40	19	0.89	0.44	80	19	1.77	0.89	160	19	3.55	1.77				
15	6	0.11	0.05	50	6	0.35	0.18	100	6	0.70	0.35	180	6	1.26	0.63				
15	9	0.16	0.08	50	9	0.53	0.26	100	9	1.05	0.53	180	9	1.89	0.95				
15	13	0.23	0.11	50	13	0.76	0.38	100	13	1.52	0.76	180	13	2.73	1.37				
15	16	0.28	0.14	50	16	0.93	0.47	100	16	1.87	0.93	180	16	3.36	1.68				
15	19	0.33	0.17	50	19	1.11	0.55	100	19	2.22	1.11	180	19	3.99	2.00				
20	6	0.14	0.07	60	6	0.42	0.21	120	6	0.84	0.42	200	6	1.40	0.70				
20	9	0.21	0.11	60	9	0.63	0.32	120	9	1.26	0.63	200	9	2.10	1.05				
20	13	0.30	0.15	60	13	0.91	0.46	120	13	1.82	0.91	200	13	3.03	1.52				
20	16	0.37	0.19	60	16	1.12	0.56	120	16	2.24	1.12	200	16	3.73	1.87				
20	19	0.44	0.22	60	19	1.33	0.67	120	19	2.66	1.33	200	19	4.43	2.22				

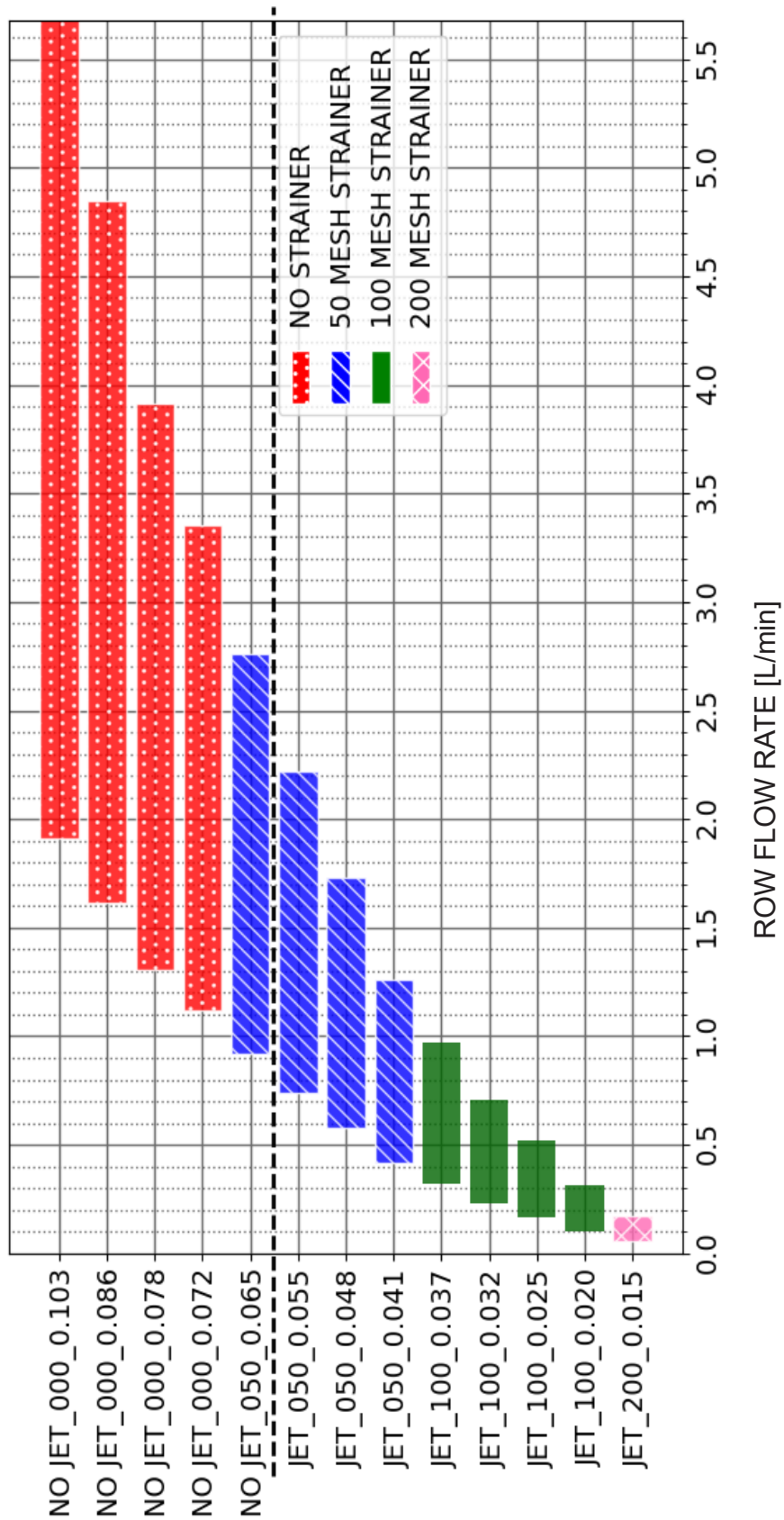

PUMP CLEAN OUT AND STORAGE

NOTE: Do not let fertilizer sit in the pump and system for longer than a day. Fertilizer will crystalize and cause issues with small moving parts and nozzles in the fertilizer system.

NOTE: Chemical solutions may become extremely corrosive if the system is not cleaned out properly.

After each use, flush out the circuit with clean water by running the pump with clean water for a few minutes. Then drain it by operating without pressure and suck-in air opening a ball valve on the suction line or remove the suction fitting until the pump runs dry.

Inspect the pump and other circuit components with regularity, or at the end of the season, replacing any components that show signs of wear.

If the pump is stored for the winter in a zone with a risk of frost, liquid antifreeze should be added to the circuit flushing water.

1. Remove as much fertilizer out of the tank(s) and row unit manifolds as possible.
2. Fill the tanks with 300-500 liters of clean water.
3. Run system on Blue Vantage so that manual run buttons can be used to clean row unit plumbing.
4. Beginning in the middle of the planter, flushing each row unit (with manual run button) for 5-10 seconds each. Row unit is clean once mostly clear water is seen. After every row has been cleaned out, repeat process on each row for an additional 2-3 seconds per row. This will clean out the components on each row unit.
5. Clean the flow meters on every row. See ["Row Flow Meter Cleanout" on page 4-22](#).
6. Cleanout complete, complete remaining steps for winterization.

Winterization

There are two methods for winterizing the pump, depending on whether ready-to-use antifreeze or antifreeze concentrate is used.

When ready-to-use anti-freeze is used:

1. Remove the suction hose barb. NOTE: The suction valve will be closed when not in a Blue Vantage task.
2. Remove the discharge manifold drain plug from the pump.

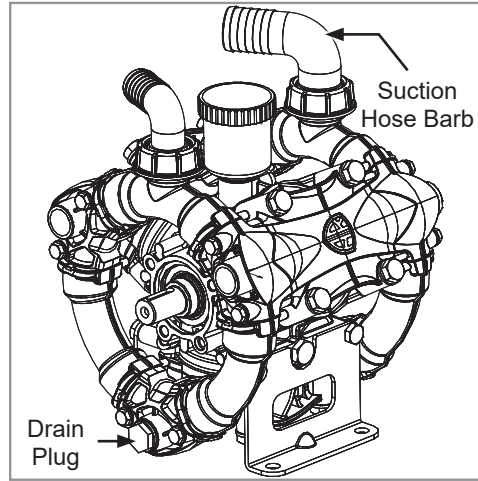

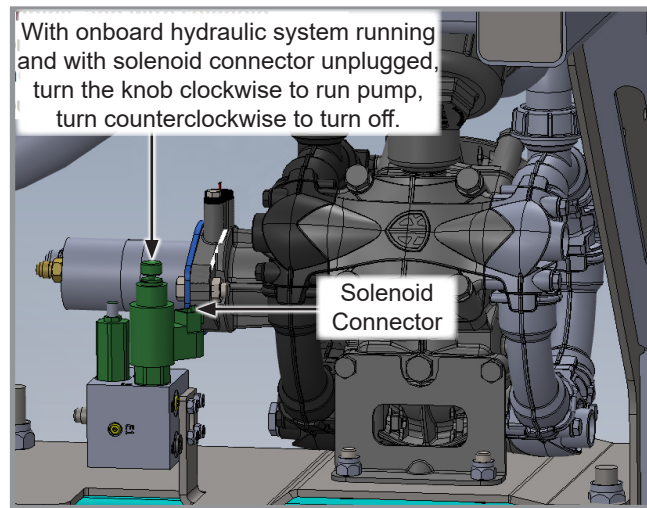

Diaphragm Pump

3. Turn the pump over by hand (or with the motor) for 15-20 seconds to remove any fluid in the manifolds and heads.



4. Reinstall the drain plug.
5. Add a 50:50 mix of water and antifreeze for fresh water systems (RV antifreeze) through the same inlet access port.
6. Run the pump for a few seconds to distribute the mix through the manifolds and heads.

7. Fill the onboard fertilizer tank with a small amount of liquid antifreeze for winter storage.

 WARNING	Antifreeze can cause death or serious injury to persons, animals, and plants or seriously damage soil, equipment, or property. Read and follow all chemical manufacturers labels and instructions.
	

8. Run the system so liquid antifreeze distributes through the manifolds and flow meter on every row unit. Use manual run buttons so antifreeze comes out of every row unit.

NOTICE	Catch any antifreeze in a container and dispose in a safe manner, to appropriate waste disposal facility, in accordance with local/regional regulations.
---------------	---

9. Wash any excess fertilizer or winterizing fluid off the planter before putting it into storage.

When antifreeze concentrate is used:

1. After the cleanout, there will be about 35 liters of water left in the system. Add the antifreeze concentrate into the L.H. fertilizer tank. Make sure to use the right ratio of the concentrate for your region.
2. Go into a planting task using Blue Vantage and leave the system to agitate for 5 minutes so the antifreeze can mix in the tank.
3. Flush the system using Blue Vantage for 2 minutes or until you see colored fluid coming out of fertilizer drop tubes.
4. Flush water remains from the quick-fill valve. Close the valve as soon as you see the antifreeze coming out.

FERTILIZER PUMP FLUID DISCHARGE PROCEDURE

If it is needed to discharge the fluid from the fertilizer pump, remove the drain plug, turn the pump over, and remove the suction filter. Open the fill-up valve via Blue Vantage and discharge the fluid.

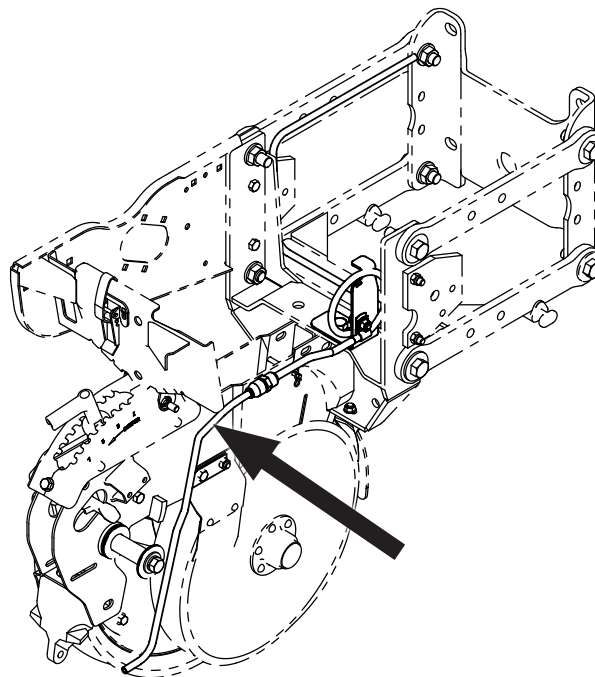
IN FURROW

In Furrow is available for in-line installation to ensure equal distribution of product at low rates and siphon protection for field turns.

LIQUID FERTILIZER 3-WAY DISTRIBUTION VALVES

The valve in the illustration below is used to control the fill-up flow. Operate the valve via the handle to set the flow to the desired fertilizer tank. The default handle position is in the middle and allows flow to both tanks.

For planting operations, turn the handle to its default position (indicated below).

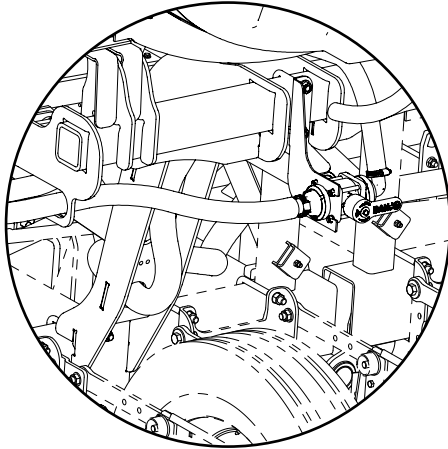

Valve location w/ Row Hoppers

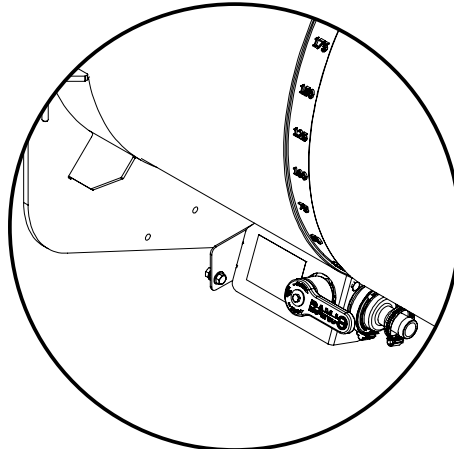

Valve location w/ Bulk Fill

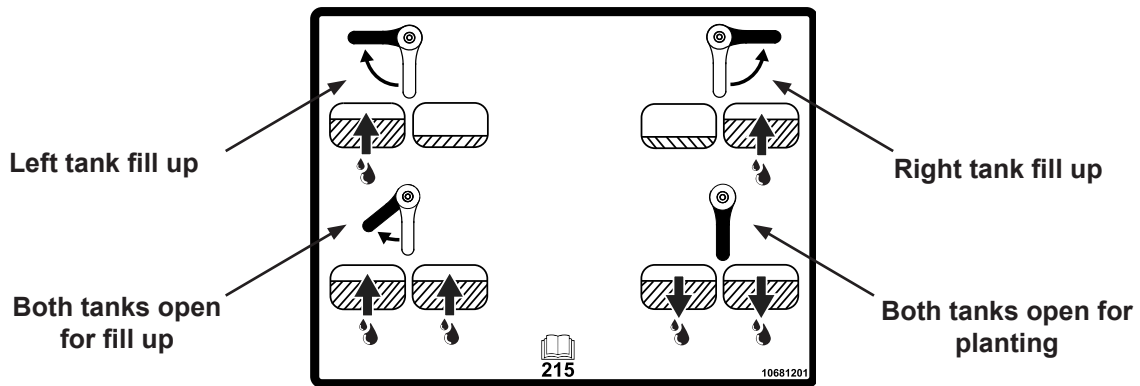

Valve functions for each handle position:



LIQUID FERTILIZER SENSORS

Blue Vantage controlled liquid fertilizer system uses sensors to determine the level of liquid in the tanks and at the pump.

The sensors have a color LED which will inform the user about following:

-  Green - powered, no liquid detected.
-  Green & Orange - powered, liquid detected.



Sensor on fertilizer tank



Sensor at the pump flow line

FERTILIZER PUMP TROUBLESHOOTING

PROBLEM	CAUSE	SOLUTION
Pump does not prime.	Air being sucked in from suction line.	Check suction line connections and inspect it for damage.
	One or more valves not properly sealing.	Check the valves and replace them (if necessary).
Pump does not reach rated working pressure.	One or more valves not properly sealing.	Check the valves and replace them (if necessary).
	Nozzles worn or not correct diameter.	Check nozzles and replace them (if necessary).
	Suction filter plugged.	Clean filter.
	Presence of air pockets or collapsed suction hose.	Check suction line.
Pressure gauge needle fluctuates.	Air being sucked in from suction line.	Check suction line connections and inspect it for damages.
	One or more valves jammed.	Check the valves and replace them (if necessary).
Flow rate falls and pump is noisy.	Oil level in tank has dropped.	Top off oil to correct level.
Excessive noise and vibrations and fall in performance.	Cavitation.	Clean filter.
	Suction hose collapsed.	Check suction line and eliminate any restriction found.
	Suction filter plugged.	Clean filter or change filter cartridge.
Oil disappears from tank (after oil topped off)	One or more diaphragms are ruptured.	Stop pump immediately and replace diaphragm.
Oil going into tank changing to milky white color.	Oil/water emulsion into tank. One or more diaphragms are ruptured.	Stop pump immediately and replace diaphragm.

FERTILIZER SYSTEM TROUBLESHOOTING

PROBLEM	CAUSE	SOLUTION
Fertilizer flow not detected.	Plugged orifice.	Clean debris from orifice.
	Row shutoff valve plugged.	Clean debris from shutoff valve, replace if necessary.
	Flow meter plugged.	Open cover and check for debris.
Fertilizer flow unexpected.	Row shutoff valve stuck open.	Clean debris from shutoff valve, replace if necessary.
Fertilizer rail pressure high.	Improper orifice selection.	Refer to orifice charts.
	Check valve on agitation line installed backwards.	Turn valve around so flow arrow points out of regulator.
No fluid detected.	Fluid inlet sensor does not have power.	Check wiring harness.
	No fluid at pump.	Clean suction strainer regularly. Ensure fluid is in tanks, prime pump.
Fertilizer Off - rail sensor error.	Rail pressure sensor is not being powered properly.	Check wiring harness.
	Rail pressure sensor is damaged.	Replace pressure sensor.
Fertilizer Off - suction sensor error.	Suction pressure sensor is not being powered properly.	Check wiring harness.
	Suction pressure sensor is damaged.	Replace pressure sensor.
Fertilizer off - high suction pressure.	Suction pressure has exceeded -7 PSI (48 kPa).	Clean suction strainer regularly.
	Suction strainer is clogged.	
	Suction hose is kinked/damaged.	Replace hose.
	Electronic ball valve is not opening.	Check wiring harness and ball valve.
Pump RPM not detected.	RPM sensor is not being powered properly.	Check wiring harness.
Pump will not run or turn on.	No hydraulic flow to motor.	Send hydraulic flow to pump.
	No fertilizer control enabled.	Blue Vantage must be on and in a fertilizer task.
Pump will not prime or pump.	Plugged suction strainer.	Clean strainers regularly.
	Suction ball valve not opening.	Check wiring harness and ball valve.
Unable to achieve rate.	Plugged row strainers or orifice.	Inspect and clean row flow components.
	Plugged pressure strainer.	Clean strainers regularly.
Flow rate does not read properly below 1.5 GPM (6 L/min).	Lower small system flow meter installed backwards.	Ensure lower small system flow meter is in correct orientation (check arrow direction).
	Lower small system flow meter does not have power/reading incorrectly.	Check wiring harness.
Analog pressure gauge needle bouncing.	Inline orifice not installed in hose.	Add orifice to system before gauge.

GENERAL PLANTING RATE INFORMATION

NOTICE	<p>Sprocket combinations in these charts are for average conditions. Changes in sprocket combinations may be required for desired planting population. <u>ALWAYS MAKE FIELD CHECKS TO BE SURE YOU ARE PLANTING AT THE DESIRED RATE.</u></p>
---------------	--

NOTE: Seed size and shape may affect planting rate.

NOTE: Not all row spacings listed apply to all size planters.

NOTE: Speeds above 5.5 MPH (~9 km/h) can adversely affect seed spacing.

NOTE: Contact wheel drive sprocket references are located in each chart title.

NOTE: DO NOT USE 44 tooth sprockets (60 cell soybean discs) with dry fertilizer.

NOTE: 15, 19, and 30 tooth drive sprockets are NOT applicable to all rate charts. Check chart titles to ensure proper rate chart is selected. 15 and 19 tooth sprockets requires 116 pitch No. 40 chain and 30 tooth sprocket requires 124 pitch No. 40 chain.

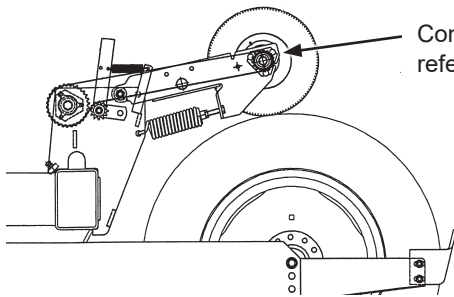

Contact wheel drive sprocket referenced in rate chart title.

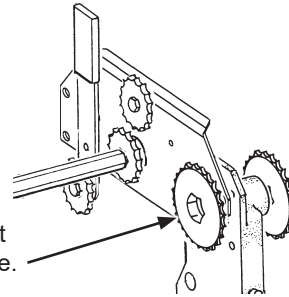

Reverser driven sprocket referenced irate chart title.

**PLANTING RATES FOR (VACUUM) CORN/SUNFLOWER 40 CELL DISC
15 TOOTH CONTACT WHEEL DRIVE/23 TOOTH REVERSER DRIVEN SPROCKETS (SEE PAGE 5-1)
APPROXIMATE SEEDS/HECTARE FOR VARIOUS ROW WIDTHS**

35 cm Rows (Seeds/Hectare)	70 cm Rows (Seeds/Hectare)	Transmission Sprockets		Recomm. Speed (km/h)	Average Spacing In Centimeters
		Drive	Driven		
127951	63976	15	28	6 to 10	22,4
132690	66344	15	27	6 to 10	21,6
137794	68897	15	26	6 to 10	20,8
143304	71652	15	25	6 to 10	19,8
145011	72504	17	28	6 to 10	19,6
149274	74638	15	24	6 to 10	19,1
150381	75189	17	27	6 to 10	19,1
155765	77883	15	23	6 to 10	18,3
156166	78081	17	26	6 to 10	18,3
162071	81035	19	28	6 to 10	17,5
162412	81205	17	25	6 to 10	17,5
168073	84038	19	27	6 to 10	17,0
169180	84591	17	24	6 to 10	16,8
174537	87268	19	26	6 to 10	16,3
176534	88268	17	23	6 to 10	16,0
181517	90760	19	25	6 to 10	15,7
188559	94278	15	19	6 to 10	15,0
189084	94539	19	24	6 to 10	15,0
196190	98095	23	28	6 to 10	14,7
197303	98654	19	23	6 to 10	14,5
203455	101729	23	27	6 to 10	14,2
204721	102361	24	28	6 to 10	14,0
210742	105371	15	17	6 to 10	13,7
212304	106150	24	27	6 to 10	13,5
213701	106849	17	19	6 to 10	13,5
219736	109868	23	25	6 to 10	13,0
221781	110889	26	28	6 to 10	13,0
228890	114442	23	24	6 to 10	12,4
229288	114644	24	25	6 to 10	12,4
230309	115155	27	28	6 to 10	12,4
238843	119420	23	23	6 to 10	11,9
247689	123844	28	27	6 to 10	11,7
248028	124011	27	26	6 to 10	11,4
249226	124613	24	23	6 to 10	11,4
257212	128607	28	26	6 to 10	11,2
257948	128976	27	25	6 to 10	11,2
259610	129803	25	23	6 to 10	10,9
266939	133470	19	17	6 to 10	10,7
268697	134349	27	24	6 to 10	10,7
26999	134999	26	23	6 to 10	10,7
27865	139324	28	24	6 to 10	10,2
280378	140189	27	23	6 to 10	10,2
289122	144562	23	19	6 to 10	9,9
290761	145382	28	23	6 to 10	9,9
301693	150846	24	19	6 to 10	9,4
314264	157133	25	19	6 to 10	9,1
323139	161571	23	17	6 to 10	8,9
326835	163417	26	19	6 to 10	8,6
337186	168594	24	17	6 to 10	8,4
339406	169702	27	19	6 to 10	8,4
351238	175617	25	17	6 to 10	8,1
351977	175988	28	19	6 to 10	8,1
365287	182643	26	17	6 to 10	7,9
366222	183111	23	15	6 to 10	7,6
379336	189667	27	17	6 to 10	7,4

NOTE: See ["General Planting Rate Information"](#) on page 5-1.

**PLANTING RATES FOR (VACUUM) CORN/SUNFLOWER 40 CELL DISC
19 TOOTH CONTACT WHEEL DRIVE/23 TOOTH REVERSER DRIVEN SPROCKETS (SEE PAGE 5-1)
APPROXIMATE SEEDS/HECTARE FOR VARIOUS ROW WIDTHS**

35 cm Rows (Seeds/Hectare)	70 cm Rows (Seeds/Hectare)	Transmission Sprockets		Recomm. Speed (km/h)	Average Spacing In Centimeters
		Drive	Driven		
162071	81035	15	28	6 to 10	17,5
168073	84038	15	27	6 to 10	17,0
174537	87268	15	26	6 to 10	16,3
181517	90760	15	25	6 to 10	15,7
183678	91840	17	28	6 to 10	15,5
189084	94539	15	24	6 to 10	15,0
190484	95243	17	27	6 to 10	15,0
197303	98654	15	23	6 to 10	14,5
197811	98904	17	26	6 to 10	14,5
205288	102646	19	28	6 to 10	14,0
205721	102861	17	25	6 to 10	14,0
212892	106446	19	27	6 to 10	13,5
214293	107148	17	24	6 to 10	13,5
221079	110540	19	26	6 to 10	13,0
223611	111806	17	23	6 to 10	13,0
229925	114961	19	25	6 to 10	12,4
238843	119420	15	19	6 to 10	11,9
239505	119754	19	24	6 to 10	11,9
248506	124256	23	28	6 to 10	11,4
249920	124957	19	23	6 to 10	11,4
257712	128857	23	27	6 to 10	11,2
259314	129656	24	28	6 to 10	10,9
266939	133470	15	17	6 to 10	10,7
26892	134459	24	27	6 to 10	10,7
270689	135343	17	19	6 to 10	10,7
278330	139162	23	25	6 to 10	10,2
280924	140461	26	28	6 to 10	10,2
289928	144963	23	24	6 to 10	9,9
290431	145215	24	25	6 to 10	9,9
291726	145863	27	28	6 to 10	9,9
302531	151266	23	23	6 to 10	9,4
313737	156867	28	27	6 to 10	9,1
314167	157085	27	26	6 to 10	9,1
31569	157843	24	23	6 to 10	9,1
325803	162901	28	26	6 to 10	8,6
326735	163369	27	25	6 to 10	8,6
328840	164420	25	23	6 to 10	8,6
338124	169062	19	17	6 to 10	8,4
340349	170175	27	24	6 to 10	8,4
341994	170994	26	23	6 to 10	8,4
352955	176475	28	24	6 to 10	8,1
355146	177574	27	23	6 to 10	7,9
366222	183111	23	19	6 to 10	7,6
368300	184151	28	23	6 to 10	7,6
382145	191129	24	19	6 to 10	7,4
398070	199034	25	19	6 to 10	7,1
409308	204654	23	17	6 to 10	6,9
413993	206995	26	19	6 to 10	6,9
427104	213551	24	17	6 to 10	6,6
429916	214957	27	19	6 to 10	6,6
444900	222450	25	17	6 to 10	6,4
445839	222918	28	19	6 to 10	6,4
462697	231350	26	17	6 to 10	6,1
463885	231941	23	15	6 to 10	6,1
480493	240246	27	17	6 to 10	5,8

NOTE: See ["General Planting Rate Information"](#) on page 5-1.

**PLANTING RATES FOR (VACUUM) MILO/SUGAR BEET/SPECIALTY 60 CELL DISCS
15 TOOTH CONTACT WHEEL DRIVE/23 TOOTH REVERSER DRIVEN SPROCKETS (SEE PAGE 5-1)**

APPROXIMATE SEEDS/HECTARE FOR VARIOUS ROW WIDTHS

35 cm Rows (Seeds/Hectare)	70 cm Rows (Seeds/Hectare)	Transmission Sprockets		Recomm. Speed (km/h)	Average Spacing In Centimeters
		Drive	Driven		
191927	95964	15	28	6 to 10	15,0
199030	99517	15	27	6 to 10	14,2
206689	103344	15	26	6 to 10	13,7
214957	107478	15	25	6 to 10	13,2
217515	108758	17	28	6 to 10	13,2
223912	111956	15	24	6 to 10	12,7
225574	112787	17	27	6 to 10	12,7
233648	116824	15	23	6 to 10	12,2
234247	117125	17	26	6 to 10	12,2
243106	121552	19	28	6 to 10	11,7
243617	121810	17	25	6 to 10	11,7
252110	126054	19	27	6 to 10	11,4
253769	126884	17	24	6 to 10	11,2
261805	130903	19	26	6 to 10	10,9
264802	132400	17	23	6 to 10	10,7
272280	13614	19	25	6 to 10	10,4
282838	141420	15	19	6 to 10	10,2
283623	141813	19	24	6 to 10	10,2
294285	147143	23	28	6 to 10	9,7
295954	147979	19	23	6 to 10	9,7
305187	152594	23	27	6 to 10	9,4
307082	153540	24	28	6 to 10	9,4
316113	158058	15	17	6 to 10	9,1
31845	15923	24	27	6 to 10	8,9
32055	16028	17	19	6 to 10	8,9
329601	164802	23	25	6 to 10	8,6
33267	166336	26	28	6 to 10	8,6
343335	171666	23	24	6 to 10	8,4
343932	171965	24	25	6 to 10	8,4
34547	172733	27	28	6 to 10	8,4
35826	179130	23	23	6 to 10	7,9
371531	185764	28	27	6 to 10	7,6
372041	186019	27	26	6 to 10	7,6
373840	186920	24	23	6 to 10	7,6
385819	192911	28	26	6 to 10	7,4
386924	193462	27	25	6 to 10	7,4
389416	19471	25	23	6 to 10	7,4
400409	200206	19	17	6 to 10	7,1
403046	201523	27	24	6 to 10	7,1
404992	202496	26	23	6 to 10	7,1
417971	208987	28	24	6 to 10	6,9
420568	210285	27	23	6 to 10	6,9
433684	216843	23	19	6 to 10	6,6
436144	218072	28	23	6 to 10	6,6
452542	226270	24	19	6 to 10	6,4
471397	235699	25	19	6 to 10	6,1
484707	242354	23	17	6 to 10	5,8
490252	245127	26	19	6 to 10	5,8
505783	252890	24	17	6 to 10	5,6
509110	254554	27	19	6 to 10	5,6
526855	263429	25	17	6 to 10	5,3
527965	263983	28	19	6 to 10	5,3
547930	273965	26	17	6 to 10	5,3
549333	274667	23	15	6 to 10	5,1
569003	284502	27	17	6 to 10	5,1

NOTE: See ["General Planting Rate Information"](#) on page 5-1.

**PLANTING RATES FOR (VACUUM) MILO/SUGAR BEET/ SPECIALTY 60 CELL DISCS
19 TOOTH CONTACT WHEEL DRIVE/23 TOOTH REVERSER DRIVEN SPROCKETS (SEE PAGE 5-1)**

APPROXIMATE SEEDS/HECTARE FOR VARIOUS ROW WIDTHS

35 cm Rows (Seeds/Hectare)	70 cm Rows (Seeds/Hectare)	Transmission Sprockets		Recomm. Speed (km/h)	Average Spacing In Centimeters
		Drive	Driven		
243106	121552	15	28	6 to 10	11,7
252110	126054	15	27	6 to 10	11,4
261805	130903	15	26	6 to 10	10,9
272280	136139	15	25	6 to 10	10,4
275521	137759	17	28	6 to 10	10,4
283623	141813	15	24	6 to 10	10,2
285724	142864	17	27	6 to 10	9,9
295954	147979	15	23	6 to 10	9,7
296715	148358	17	26	6 to 10	9,7
307934	153967	19	28	6 to 10	9,4
308582	154292	17	25	6 to 10	9,1
319338	159671	19	27	6 to 10	8,9
321440	160722	17	24	6 to 10	8,9
331622	165810	19	26	6 to 10	8,6
335417	167707	17	23	6 to 10	8,6
344886	172443	19	25	6 to 10	8,4
35826	179130	15	19	6 to 10	7,9
359258	17963	19	24	6 to 10	7,9
372762	186382	23	28	6 to 10	7,6
374877	187439	19	23	6 to 10	7,6
386569	193285	23	27	6 to 10	7,4
388969	194486	24	28	6 to 10	7,4
400409	200206	15	17	6 to 10	7,1
403376	201687	24	27	6 to 10	7,1
406029	203015	17	19	6 to 10	7,1
417495	208748	23	25	6 to 10	6,9
421385	210691	26	28	6 to 10	6,9
434891	217446	23	24	6 to 10	6,6
435646	217822	24	25	6 to 10	6,6
437592	218795	27	28	6 to 10	6,6
453797	226899	23	23	6 to 10	6,4
470604	235303	28	27	6 to 10	6,1
471252	235626	27	26	6 to 10	6,1
473529	236763	24	23	6 to 10	6,1
488707	244353	28	26	6 to 10	5,8
490102	245052	27	25	6 to 10	5,8
493260	246630	25	23	6 to 10	5,8
507186	253594	19	17	6 to 10	5,6
510524	255261	27	24	6 to 10	5,6
512989	256494	26	23	6 to 10	5,6
529430	264716	28	24	6 to 10	5,3
532720	266359	27	23	6 to 10	5,3
549333	274667	23	19	6 to 10	5,1
552449	276226	28	23	6 to 10	5,1
573218	286609	24	19	6 to 10	5,1
59710	298551	25	19	6 to 10	4,8
613962	306980	23	17	6 to 10	4,6
620986	310493	26	19	6 to 10	4,6
640655	320328	24	17	6 to 10	4,6
644872	322435	27	19	6 to 10	4,3
667351	333675	25	17	6 to 10	4,3
668756	334377	28	19	6 to 10	4,3
	347023	26	17	6 to 10	4,1
	347913	23	15	6 to 10	4,1
	360368	27	17	6 to 10	4,1

NOTE: See ["General Planting Rate Information"](#) on page 5-1.

**PLANTING RATES FOR (VACUUM) SPECIALTY 60 CELL DISC
30 TOOTH CONTACT WHEEL DRIVE/17 TOOTH REVERSER DRIVEN SPROCKETS (SEE PAGE 5-1)
APPROXIMATE SEEDS/HECTARE FOR VARIOUS ROW WIDTHS**

35 cm Rows (Seeds/Hectare)	70 cm Rows (Seeds/Hectare)	Transmission Sprockets		Recomm. Speed (km/h)	Average Spacing In Centimeters
		Drive	Driven		
519335	259666	15	28	6 to 10	5,6
538569	269283	15	27	6 to 10	5,3
559281	27964	15	26	6 to 10	5,1
581655	290826	15	25	6 to 10	4,8
588578	294288	17	28	6 to 10	4,8
605888	30295	15	24	6 to 10	4,8
610377	305190	17	27	6 to 10	4,6
63223	31612	15	23	6 to 10	4,6
633852	316927	17	26	6 to 10	4,6
657822	328913	19	28	6 to 10	4,3
659207	329603	17	25	6 to 10	4,3
NOTE: Planting rates over 670,000 seeds/hectare are not recommended with subject seed disc and/or drive ratio.	341094	19	27	6 to 10	4,1
	343338	17	24	6 to 10	4,1
	354213	19	26	6 to 10	4,1
	358264	17	23	6 to 10	4,1
	368381	19	25	6 to 10	3,8
	38267	15	19	6 to 10	3,8
	383731	19	24	6 to 10	3,8
	398156	23	28	6 to 10	3,6
	400414	19	23	6 to 10	3,6
	412902	23	27	6 to 10	3,6
415466	24	28	6 to 10	3,6	
42769	15	17	6 to 10	3,3	
430854	24	27	6 to 10	3,3	
433690	17	19	6 to 10	3,3	
445935	23	25	6 to 10	3,3	
450088	26	28	6 to 10	3,0	
464516	23	24	6 to 10	3,0	
465323	24	25	6 to 10	3,0	
467400	27	28	6 to 10	3,0	
484713	23	23	6 to 10	3,0	
502665	28	27	6 to 10	2,8	
503355	27	26	6 to 10	2,8	
505785	24	23	6 to 10	2,8	
521996	28	26	6 to 10	2,8	
523487	27	25	6 to 10	2,8	
526861	25	23	6 to 10	2,8	
541735	19	17	6 to 10	2,5	
545299	27	24	6 to 10	2,5	
547936	26	23	6 to 10	2,5	
565495	28	24	6 to 10	2,5	
569008	27	23	6 to 10	2,5	
586756	23	19	6 to 10	2,5	
590084	28	23	6 to 10	2,5	
612266	24	19	6 to 10	2,3	
637779	25	19	6 to 10	2,3	
655785	23	17	6 to 10	2,3	
663289	26	19	6 to 10	2,0	
		24	17	6 to 10	2,0
		27	19	6 to 10	2,0
		25	17	6 to 10	2,0
		28	19	6 to 10	2,0
		26	17	6 to 10	2,0
		23	15	6 to 10	2,0
		27	17	6 to 10	1,8

NOTE: See ["General Planting Rate Information"](#) on page 5-1.

**PLANTING RATES FOR (VACUUM) SOYBEAN 120 CELL DISC
15 TOOTH CONTACT WHEEL DRIVE/23 TOOTH REVERSER DRIVEN SPROCKETS (SEE PAGE 5-1)
APPROXIMATE SEEDS/HECTARE FOR VARIOUS ROW WIDTHS**

35 cm Rows (Seeds/Hectare)	70 cm Rows (Seeds/Hectare)	Transmission Sprockets		Recomm. Speed (km/h)	Average Spacing In Centimeters
		Drive	Driven		
383852	191927	15	28	6 to 10	7,4
398068	199034	15	27	6 to 10	7,1
413378	206689	15	26	6 to 10	6,9
429913	214957	15	25	6 to 10	6,6
435031	217515	17	28	6 to 10	6,6
447828	223912	15	24	6 to 10	6,4
451144	225574	17	27	6 to 10	6,4
467298	233648	15	23	6 to 10	6,1
468497	234247	17	26	6 to 10	6,1
486212	243106	19	28	6 to 10	5,8
487237	243617	17	25	6 to 10	5,8
504221	252110	19	27	6 to 10	5,6
507538	253769	17	24	6 to 10	5,6
523614	261805	19	26	6 to 10	5,3
529605	264802	17	23	6 to 10	5,3
544557	272280	19	25	6 to 10	5,3
565675	282838	15	19	6 to 10	5,1
567248	283623	19	24	6 to 10	5,1
588573	294285	23	28	6 to 10	4,8
591911	295954	19	23	6 to 10	4,8
610371	305187	23	27	6 to 10	4,6
614164	307082	24	28	6 to 10	4,6
632226	316113	15	17	6 to 10	4,6
636911	318454	24	27	6 to 10	4,6
641099	320551	17	19	6 to 10	4,6
659201	329601	23	25	6 to 10	4,3
665343	332673	26	28	6 to 10	4,3
	343335	23	24	6 to 10	4,1
	343932	24	25	6 to 10	4,1
	345467	27	28	6 to 10	4,1
	358261	23	23	6 to 10	4,1
	371531	28	27	6 to 10	3,8
	372041	27	26	6 to 10	3,8
	373840	24	23	6 to 10	3,8
	385819	28	26	6 to 10	3,8
	386924	27	25	6 to 10	3,8
	389416	25	23	6 to 10	3,6
	400409	19	17	6 to 10	3,6
	403046	27	24	6 to 10	3,6
	404992	26	23	6 to 10	3,6
	417971	28	24	6 to 10	3,3
	420568	27	23	6 to 10	3,3
	433684	23	19	6 to 10	3,3
	436144	28	23	6 to 10	3,3
	452542	24	19	6 to 10	3,0
	471397	25	19	6 to 10	3,0
	484707	23	17	6 to 10	3,0
	490252	26	19	6 to 10	2,8
	505783	24	17	6 to 10	2,8
	509110	27	19	6 to 10	2,8
	526855	25	17	6 to 10	2,8
	527965	28	19	6 to 10	2,8
	547930	26	17	6 to 10	2,5
	549333	23	15	6 to 10	2,5
	569003	27	17	6 to 10	2,5

NOTE: Planting rates over 670,000 seeds/hectare are not recommended with subject seed disc and/or drive ratio.

NOTE: See ["General Planting Rate Information" on page 5-1.](#)

**PLANTING RATES FOR (VACUUM) SOYBEAN 120 CELL DISC
19 TOOTH CONTACT WHEEL DRIVE/23 TOOTH REVERSER DRIVEN SPROCKETS (SEE PAGE 5-1)
APPROXIMATE SEEDS/HECTARE FOR VARIOUS ROW WIDTHS**

35 cm Rows (Seeds/Hectare)	70 cm Rows (Seeds/Hectare)	Transmission Sprockets		Recomm. Speed (km/h)	Average Spacing In Centimeters
		Drive	Driven		
486212	243106	15	28	6 to 10	5,8
504221	252110	15	27	6 to 10	5,6
523614	261805	15	26	6 to 10	5,3
544557	272280	15	25	6 to 10	5,3
551040	275521	17	28	6 to 10	5,1
567248	283623	15	24	6 to 10	5,1
571449	285724	17	27	6 to 10	5,1
591911	295954	15	23	6 to 10	4,8
593427	296715	17	26	6 to 10	4,8
615868	307934	19	28	6 to 10	4,6
617166	308582	17	25	6 to 10	4,6
638680	319338	19	27	6 to 10	4,6
642881	321440	17	24	6 to 10	4,3
663244	331622	19	26	6 to 10	4,3
670831	335417	17	23	6 to 10	4,3
	344886	19	25	6 to 10	4,1
NOTE: Planting rates over 670,000 seeds/hectare are not recommended with subject seed disc and/or drive ratio.	35826	15	19	6 to 10	4,1
	359258	19	24	6 to 10	4,1
	372762	23	28	6 to 10	3,8
	374877	19	23	6 to 10	3,8
	386569	23	27	6 to 10	3,8
	388969	24	28	6 to 10	3,6
	400409	15	17	6 to 10	3,6
	403376	24	27	6 to 10	3,6
	406029	17	19	6 to 10	3,6
	417495	23	25	6 to 10	3,3
421385	26	28	6 to 10	3,3	
4349	23	24	6 to 10	3,3	
435646	24	25	6 to 10	3,3	
437592	27	28	6 to 10	3,3	
453797	23	23	6 to 10	3,0	
470604	28	27	6 to 10	3,0	
471252	27	26	6 to 10	3,0	
473529	24	23	6 to 10	3,0	
488707	28	26	6 to 10	2,8	
490102	27	25	6 to 10	2,8	
493260	25	23	6 to 10	2,8	
507186	19	17	6 to 10	2,8	
510524	27	24	6 to 10	2,8	
512989	26	23	6 to 10	2,8	
529430	28	24	6 to 10	2,8	
532720	27	23	6 to 10	2,8	
549333	23	19	6 to 10	2,5	
552449	28	23	6 to 10	2,5	
573218	24	19	6 to 10	2,5	
59710	25	19	6 to 10	2,3	
613962	23	17	6 to 10	2,3	
620986	26	19	6 to 10	2,3	
640655	24	17	6 to 10	2,3	
644872	27	19	6 to 10	2,3	
667351	25	17	6 to 10	2,0	
668756	28	19	6 to 10	2,0	
		26	17	6 to 10	2,0
		23	15	6 to 10	2,0
		27	17	6 to 10	2,0

NOTE: See ["General Planting Rate Information"](#) on page 5-1.

**PLANTING RATES FOR (VACUUM) RAPESSED 83 CELL DISCS
15 TOOTH CONTACT WHEEL DRIVE/23 TOOTH REVERSER DRIVEN SPROCKETS (SEE PAGE 5-1)**

APPROXIMATE SEEDS/HECTARE FOR VARIOUS ROW WIDTHS

35 cm Rows (Seeds/Hectare)	Transmission Sprockets		Recomm. Speed (km/h)	Average Spacing In Centimeters
	Drive	Driven		
265499	15	28	6 to 10	10,1
275330	15	27	6 to 10	9,7
285920	15	26	6 to 10	9,4
297357	15	25	6 to 10	9,0
300896	17	28	6 to 10	8,9
309746	15	24	6 to 10	8,6
312043	17	27	6 to 10	8,6
323213	15	23	6 to 10	8,3
324042	17	26	6 to 10	8,3
336297	19	28	6 to 10	8,0
337003	17	25	6 to 10	7,9
348753	19	27	6 to 10	7,7
351047	17	24	6 to 10	7,6
362164	19	26	6 to 10	7,4
366310	17	23	6 to 10	7,3
376654	19	25	6 to 10	7,1
391259	15	19	6 to 10	6,8
392345	19	24	6 to 10	6,8
407095	23	28	6 to 10	6,6
409404	19	23	6 to 10	6,5
422175	23	27	6 to 10	6,3
424797	24	28	6 to 10	6,3
437290	15	17	6 to 10	6,1
440528	24	27	6 to 10	6,1
443428	17	19	6 to 10	6,0
455948	23	25	6 to 10	5,9
460197	26	28	6 to 10	5,8
474947	23	24	6 to 10	5,6
475773	24	25	6 to 10	5,6
477896	27	28	6 to 10	5,6
495594	23	23	6 to 10	5,4
513951	28	27	6 to 10	5,2
514657	27	26	6 to 10	5,2
517145	24	23	6 to 10	5,2
533717	28	26	6 to 10	5,0
535245	27	25	6 to 10	5,0
538692	25	23	6 to 10	5,0
553899	19	17	6 to 10	4,8
557546	27	24	6 to 10	4,8
560238	26	23	6 to 10	4,8
578193	28	24	6 to 10	4,6
581785	27	23	6 to 10	4,6
599930	23	19	6 to 10	4,5
603332	28	23	6 to 10	4,4
626016	24	19	6 to 10	4,3
652099	25	19	6 to 10	4,1
670512	23	17	6 to 10	4,0
678182	26	19	6 to 10	3,9
699666	24	17	6 to 10	3,8
704269	27	19	6 to 10	3,8
728816	25	17	6 to 10	3,7
730352	28	19	6 to 10	3,7
757970	26	17	6 to 10	3,5
759911	23	15	6 to 10	3,5
787121	27	17	6 to 10	3,4

NOTE: See ["General Planting Rate Information" on page 5-1.](#)

**PLANTING RATES FOR (VACUUM) RAPESED 83 CELL DISCS
19 TOOTH CONTACT WHEEL DRIVE/23 TOOTH REVERSER DRIVEN SPROCKETS
(SEE PAGE 5-1)**

APPROXIMATE SEEDS/HECTARE FOR VARIOUS ROW WIDTHS

35 cm Rows (Seeds/Hectare)	Transmission Sprockets		Recomm. Speed (km/h)	Average Spacing In Centimeters
	Drive	Driven		
336297	15	28	6 to 10	8,0
348753	15	27	6 to 10	7,7
362164	15	26	6 to 10	7,5
376654	15	25	6 to 10	7,2
381138	17	28	6 to 10	7,1
392345	15	24	6 to 10	6,9
395252	17	27	6 to 10	6,8
409404	15	23	6 to 10	6,6
410456	17	26	6 to 10	6,6
425975	19	28	6 to 10	6,3
426871	17	25	6 to 10	6,3
441752	19	27	6 to 10	6,1
444659	17	24	6 to 10	6,1
458744	19	26	6 to 10	5,9
463994	17	23	6 to 10	5,8
477093	19	25	6 to 10	5,7
495594	15	19	6 to 10	5,4
496974	19	24	6 to 10	5,4
515654	23	28	6 to 10	5,2
518580	19	23	6 to 10	5,2
534754	23	27	6 to 10	5,0
538074	24	28	6 to 10	5,0
553899	15	17	6 to 10	4,9
558004	24	27	6 to 10	4,8
561674	17	19	6 to 10	4,8
577535	23	25	6 to 10	4,7
582915	26	28	6 to 10	4,6
601599	23	24	6 to 10	4,5
602644	24	25	6 to 10	4,5
605336	27	28	6 to 10	4,5
627753	23	23	6 to 10	4,3
651002	28	27	6 to 10	4,1
651899	27	26	6 to 10	4,1
655048	24	23	6 to 10	4,1
676044	28	26	6 to 10	4,0
677974	27	25	6 to 10	4,0
682343	25	23	6 to 10	4,0
701607	19	17	6 to 10	3,8
706225	27	24	6 to 10	3,8
709634	26	23	6 to 10	3,8
732378	28	24	6 to 10	3,7
736929	27	23	6 to 10	3,7
759911	23	19	6 to 10	3,6
764221	28	23	6 to 10	3,5
792951	24	19	6 to 10	3,4
825991	25	19	6 to 10	3,3
849315	23	17	6 to 10	3,2
859030	26	19	6 to 10	3,1
886240	24	17	6 to 10	3,0
892073	27	19	6 to 10	3,0
923169	25	17	6 to 10	2,9
925113	28	19	6 to 10	2,9
	26	17	6 to 10	2,8
	23	15	6 to 10	2,8
	27	17	6 to 10	2,7

NOTE: See ["General Planting Rate Information" on page 5-1.](#)

**DRY INSECTICIDE APPLICATION RATES
APPROXIMATE KILOGRAMS/HECTARE AT 8 KM/H FOR 70 CM ROW WIDTH**

Meter Setting	70 cm Rows
CLAY GRANULES	
10	6,0
11	6,0
12	7,4
13	8,4
14	9,4
15	10,4
16	11,7
17	13,1
18	13,9
19	16,0
20	17,3
21	18,9
22	20,0
23	21,0
24	22,9
25	25,5
26	28,1
27	29,4
28	31,0
29	33,9
30	36,1

SAND GRANULES	
5	3,5
6	6,0
7	6,5
8	7,7
9	9,5
10	10,9
11	12,4
12	13,7
13	15,4
14	17,6
15	18,9
16	21,4
17	23,7
18	26,6
19	29,6
20	31,4
21	33,7
22	36,1
23	39,0
24	42,0
25	45,0

NOTE: Above chart represents average values and should be used only as a starting point, Granular chemical flows through given meter opening at a nearly uniform rate regardless of roller speed, Your actual rate will vary with specific insecticide, planting speed, and plant population, Planting speed/ground speed has the greatest effect on application rate,

Your actual rate must be field checked with actual insecticide you are using at speed and population you are planting, See ["Granular Chemical Application Field Check" on page 2-37](#) for additional information.

DRY FERTILIZER APPLICATION RATES
APPROXIMATE RATE IN KG PER HECTARE

Drive Sprocket	Driven Sprocket	Low Rate Position	High Rate Position
		70 cm Rows	70 cm Rows
15	35	39	115
15	33	44	133
15	30	48	147
19	33	55	165
19	30	61	187
15	19	71	213
30	35	75	230
30	33	82	245
33	35	84	252
35	33	93	262
33	30	99	295
19	15	114	340
30	19	142	424
33	19	155	467
35	19	163	492
30	15	179	538
33	15	197	589
35	15	205	624



High rate setting

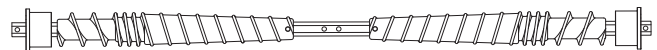

Low rate setting

NOTE: Uneven delivery may result from attempting to use lower rates than indicated by chart.

Above chart is for planters equipped with contact drive. Check tires for correct operating pressure.

Chart calculated with a bulk density of 1041 kilograms per cubic meter.

NOTE: Fertilizer application rates can vary from weights calculated in above chart. Make field checks to be sure you are applying fertilizer at desired rate.

To check exact number of kilograms your fertilizer attachment will actually deliver on 70 cm row spacing:

1. Remove one spout from one fertilizer hopper and attach a container under opening.
2. Engage fertilizer attachment and drive forward 14.28 m.
3. Weigh amount of fertilizer caught in container and multiply by 1000. Result is kilograms of fertilizer delivered per hectare when planting in 70 cm rows.

**LIQUID FERTILIZER PISTON PUMP APPLICATION RATES
LITERS PER HECTARE**

Applies to Model LM-2455-R And NGP-6055 Pump With 18 Tooth Sprocket

Pump Setting	1	2	3	4	5	6	7	8	9	10
8 Row 70 cm	41,7	84,3	126,0	168,0	209,0	252,0	293,7	335,0	377,0	419,7

Above chart is for planters equipped with contact drive. Check tires for correct operating pressure.

Chart is based on average wheel slippage and liquid viscosities.

Measure and weigh one kilogram of actual fertilizer solution to determine exact application rate.

NOTE: Fertilizer application rates can vary from the above chart. To prevent application miscalculations, make field checks to be sure you are applying fertilizer to all rows at the desired rate.

NOTE: Periodically check flow to all rows. Desired rate is delivered to remaining rows keeping total application rate at desired rate if one or more lines are plugged.

To check the exact number of liters your fertilizer attachment will actually deliver on a 70 cm row spacing:

1. Remove hose from one fertilizer opener and insert it into a collection container secured planter frame.
2. Engage fertilizer attachment and drive forward for 14,28 m.
3. Measure fluid milliliters caught in container. Result is liters of fertilizer delivered per hectare when planting in 70 cm rows (e.g. 2ml = 2 l ; 5 ml= 5 l; 10 ml = 10 l)
4. Rinse collection container and repeat test on other rows if necessary.

Wheat Disc Section

NOTE: Graphite needs to be used unless wheat has been treated, then use 80/20 and graphite. Refer to additives section for additional information.

NOTE: Verify actual rate by determining seed usage with bulk fill scales and seed density (sds/gram). Adjust target rate as necessary.

NOTE: Rates will vary depending on travel speed and vacuum.

231 cell wheat disc refer to ["PLANTING RATES FOR \(VACUUM\) WHEAT 231 CELL DISC" on page 5-24](#)

Brush-Type seed meters refer to ["PLANTING RATES FOR BRUSH-TYPE SEED METERS \(HALF RATE DRIVE\)" on page 5-15](#)

Use a 28 tooth Drive sprocket and a 27 tooth Driven sprocket

Drive	Driven	RPM/GS
27	28	3.671
15	15	3.807
28	27	3.948
27	26	3.953

FOR HYDRAULIC DRIVE (BRUSH-TYPE AND VACUUM) AND ELECTRIC DRIVE (VACUUM)

- a. Brush-Type: use the instructions found on page 5-16 to find the seeds per revolution (SDS/REV). The SDS/REV will be relatively constant at all speeds for the Brush-Type Meter.
- b. Vacuum: use the instructions found on page 5-16 to find the seeds per revolution (SDS/REV) or look it up in Rate Chart. The SDS/REV will decrease as the disc speed increases (less SDS/REV as ground speed increases) for the True Rate Vacuum Meter.
- c. Divide the SDS/REV by the number of Cells to get the SDS/CELL. Some display may not support 54 cells as an option for number of cells on a seed disc, in that case, substitute a useable number of cells (60 or 40) and use that Cell number in the calculation. DO NOT PHYSICALLY CHANGE THE DISC, THE CELL COUNT IS FOR THE MONITOR ONLY.
- d. Divide your target population by the SDS/CELL to get your Monitor Population.

Seed Meter Type	Target Population	SDS/REV	Cells	SDS/CELL	Monitor Population
Brush	800,000	465	54	8.611	92,903
Brush	1,200,000	465	54	8.611	139,355
Vacuum	808,755	891	54	16.500	49,015
Vacuum	1,195,655	771	54	14.278	83,742
Vacuum	808,755	891	60	14.85	54,461
Vacuum	1,195,655	771	60	12.85	93,047

**PLANTING RATES FOR BRUSH-TYPE SEED METERS (HALF RATE DRIVE)
APPROXIMATE SEEDS/HECTARE FOR 35 CM ROW WIDTH**

Transmission Sprockets		Population Factor	Rye 400 SDS/REV, 35.9 SDS/GRAM		Wheat 465 SDS/REV, 39.6 SDS/GRAM		Speed Range (km/h)
Drive	Driven		Population (sds/hectare)	Population (kg/hectare)	Population (sds/hectare)	Population (kg/hectare)	
15	28	3,199.59	1,279,835	35	1,488,134	38	6 to 10
15	27	3,318.09	1,327,237	37	1,543,253	39	6 to 10
15	26	3,445.71	1,378,285	39	1,602,606	40	6 to 10
15	25	3,583.54	1,433,415	40	1,666,710	43	6 to 10
17	28	3,626.20	1,450,480	40	1,686,552	43	6 to 10
15	24	3,732.85	1,493,141	41	1,736,156	44	6 to 10
17	27	3,760.50	1,504,201	41	1,749,020	44	6 to 10
15	23	3,895.15	1,558,060	44	1,811,644	46	6 to 10
17	26	3,905.14	1,562,054	44	1,816,288	46	6 to 10
19	28	4,052.81	1,621,122	45	1,884,970	47	6 to 10
17	25	4,061.35	1,624,538	45	1,888,940	47	6 to 10
19	27	4,202.91	1,681,166	46	1,954,784	50	6 to 10
17	24	4,230.56	1,692,226	47	1,967,643	50	6 to 10
19	26	4,364.57	1,745,827	49	2,029,968	51	6 to 10
17	23	4,414.50	1,765,800	49	2,053,194	52	6 to 10
19	25	4,539.15	1,815,659	51	2,111,167	54	6 to 10
15	19	4,715.18	1,886,072	52	2,193,041	55	6 to 10
19	24	4,728.28	1,891,314	52	2,199,132	56	6 to 10
23	28	4,906.04	1,962,415	55	2,281,807	57	6 to 10
19	23	4,933.86	1,973,542	55	2,294,746	58	6 to 10
23	27	5,087.74	2,035,096	57	2,366,318	60	6 to 10
24	28	5,119.34	2,047,737	57	2,381,015	60	6 to 10
15	17	5,269.91	2,107,963	58	2,451,046	62	6 to 10
23	26	5,283.42	2,113,369	58	2,457,328	62	6 to 10
24	27	5,308.94	2,123,577	60	2,469,203	62	6 to 10
25	28	5,332.64	2,133,057	60	2,480,225	62	6 to 10
17	19	5,343.87	2,137,548	60	2,485,445	63	6 to 10
23	25	5,494.76	2,197,904	61	2,555,624	65	6 to 10
24	26	5,513.14	2,205,255	61	2,564,172	65	6 to 10
25	27	5,530.15	2,212,060	62	2,572,085	65	6 to 10
26	28	5,545.95	2,218,380	62	2,579,433	65	6 to 10
23	24	5,723.70	2,289,481	63	2,662,105	67	6 to 10
24	25	5,733.66	2,293,464	63	2,666,737	67	6 to 10
25	26	5,742.85	2,297,138	65	2,671,010	67	6 to 10
26	27	5,751.36	2,300,544	65	2,674,969	67	6 to 10
27	28	5,759.26	2,303,705	65	2,678,644	68	6 to 10
15	15	5,972.56	2,389,025	67	2,777,852	71	6 to 10
28	27	6,193.77	2,477,508	69	2,880,734	73	6 to 10
27	26	6,202.28	2,480,911	69	2,884,693	73	6 to 10
26	25	6,211.47	2,484,588	69	2,888,966	73	6 to 10
25	24	6,221.42	2,488,568	69	2,893,595	73	6 to 10
24	23	6,232.24	2,492,896	69	2,898,626	73	6 to 10

Continued on the next page.

**PLANTING RATES FOR BRUSH-TYPE SEED METERS (HALF RATE DRIVE)
APPROXIMATE SEEDS/HECTARE FOR 35 CM ROW WIDTH**

Transmission Sprockets		Population Factor	Rye 400 SDS/REV, 35.9 SDS/GRAM		Wheat 465 SDS/REV, 39.6 SDS/GRAM		Speed Range (km/h)
Drive	Driven		Population (sds/hectare)	Population (kg/hectare)	Population (sds/hectare)	Population (kg/hectare)	
28	26	6,431.99	2,572,797	72	2,991,531	75	6 to 10
27	25	6,450.37	2,580,148	72	3,000,079	75	6 to 10
26	24	6,470.27	2,588,109	72	3,009,338	75	6 to 10
25	23	6,491.92	2,596,767	72	3,019,404	77	6 to 10
19	17	6,675.22	2,670,088	74	3,104,657	78	6 to 10
28	25	6,689.27	2,675,709	74	3,111,194	78	6 to 10
27	24	6,719.13	2,687,653	74	3,125,082	79	6 to 10
26	23	6,751.60	2,700,638	75	3,140,179	79	6 to 10
17	15	6,768.91	2,707,562	75	3,148,232	79	6 to 10
28	24	6,967.99	2,787,197	78	3,240,828	82	6 to 10
27	23	7,011.27	2,804,507	78	3,260,957	83	6 to 10
23	19	7,229.94	2,891,977	80	3,362,662	85	6 to 10
28	23	7,270.94	2,908,378	82	3,381,732	85	6 to 10
24	19	7,544.29	3,017,716	84	3,508,866	89	6 to 10
19	15	7,565.25	3,026,100	84	3,518,612	89	6 to 10
25	19	7,858.63	3,143,453	88	3,655,065	92	6 to 10
23	17	8,080.53	3,232,210	90	3,758,270	95	6 to 10
26	19	8,172.98	3,269,192	91	3,801,270	96	6 to 10
24	17	8,431.86	3,372,744	94	3,921,674	99	6 to 10
27	19	8,487.33	3,394,932	95	3,947,474	100	6 to 10
25	17	8,783.18	3,513,272	97	4,085,075	103	6 to 10
28	19	8,801.67	3,520,668	99	4,093,676	103	6 to 10
26	17	9,134.51	3,653,805	102	4,248,479	107	6 to 10
23	15	9,157.93	3,663,172	102	4,259,370	107	6 to 10
27	17	9,485.83	3,794,333	106	4,411,881	111	6 to 10
24	15	9,556.10	3,822,439	106	4,444,562	112	6 to 10
28	17	9,837.16	3,934,866	110	4,575,285	116	6 to 10
25	15	9,954.27	3,981,709	111	4,629,753	117	6 to 10
26	15	10,352.44	4,140,977	116	4,814,942	122	6 to 10
27	15	10,750.62	4,300,247	119	5,000,134	127	6 to 10
28	15	11,148.79	4,459,514	124	5,185,323	130	6 to 10

NOTE: Seed size and type affect the output rate of the meter. For a method to improve the population accuracy with your desired seed, please see the following pages.

NOTE: See “Mechanical Meter” in ["General Planting Rate Information" on page 5-1](#) and ["Check Seed Population" on page 2-33](#) for additional information.

NOTE: When using Half Rate (2 To 1) Drive Reduction Package, rates are approximately 50% of given numbers.

NOTE: Always field check seed population to ensure planting rates are correct.

To more accurately predict population when using the 54 Cell Singulated Wheat Disc, two things are needed:

1. Seeds/gram
2. Grams/revolution of seed disc

Seeds per gram can be found by weighing a small sample of desired seed (a cup or less) and counting number of seeds in sample.

$$\frac{\text{Seeds}}{\text{Grams}} = \frac{\text{number of seeds in sample}}{\text{weight of sample in grams}} \quad \frac{396 \text{ Seeds}}{10 \text{ Grams}} = 39.6 \frac{\text{seeds}}{\text{gram}}$$

To find grams/revolution a gram scale, a stopwatch, a small container to catch seed, and a method for spinning the meter at a constant, known rpm (see your local Kinze dealer with a T4000 Seed Meter Test Stand) are needed.

1. Zero gram scale with the small container on it.
2. Load meter with correct disc.
3. Load meter with desired seed.
4. Start spinning meter at a known, constant rpm.
5. Start stopwatch as you place container under meter.
6. Catch seed with container for 10-30 seconds.
7. Stop the stopwatch as you remove container from underneath meter.
8. Weigh container.
9. Enter meter rpm, weight of sample, and duration of sample collection into the equation below:

$$\frac{\text{Grams}}{\text{Rev}} = \frac{\text{Sample Weight} * 60}{\text{Disc RPM} * \text{Sample Duration}}$$

EX: For a sample taken for 30 seconds with meter spinning at 50rpm and weighs 293 grams

$$\frac{293 \text{ Grams} * 60}{50 \text{ RPM} * 30 \text{ Seconds}} = 11.7 \frac{\text{Grams}}{\text{Rev}}$$

10. Find desired output rate. For seeds per hectare, use seeds/rev. For kilograms per hectare, use kg/rev.

a. Seeds/rev:

$$\frac{\text{Seeds}}{\text{Rev}} = \frac{\text{Seeds}}{\text{Grams}} * \frac{\text{Grams}}{\text{Rev}} \quad \left| \quad 39.6 \frac{\text{Seeds}}{\text{Grams}} * 11.7 \frac{\text{Grams}}{\text{Rev}} = 465 \frac{\text{Seeds}}{\text{Rev}} \right.$$

b. Kg/rev:

$$\frac{\text{Kilograms}}{\text{Rev}} = \frac{\frac{\text{Grams}}{\text{Rev}}}{1000 \frac{\text{Grams}}{\text{Grams}}} \quad \left| \quad \frac{11.7 \frac{\text{Grams}}{\text{Rev}}}{1000 \frac{\text{Grams}}{\text{Grams}}} = 0.0117 \frac{\text{Kilograms}}{\text{Rev}} \right.$$

11. Find the correct population factor by dividing the desired population by the measured output rate.

Seeds/hectare:

$$\frac{\text{Target Population}}{\text{Output Rate}} = \text{Population Factor} \quad \left| \quad \frac{2,687,831 \frac{\text{Seeds}}{\text{Hectare}}}{465 \frac{\text{Seeds}}{\text{Rev.}}} = 5780.28$$

kg/hectare:

$$\frac{\text{Target Population}}{\text{Output Rate}} = \text{Population Factor} \quad \left| \quad \frac{68 \frac{\text{kg}}{\text{hectare}}}{0.0117 \frac{\text{kg}}{\text{rev}}} = 5811.97$$

12. Find the closest Population Factor in the Rate Chart to identify the correct transmission sprockets. For the examples list above, the closest Population Factor is 5759.26 which corresponds to a 27 tooth Drive sprocket and 28 tooth Driven sprocket.

NOTE: Multiple trials are recommended to increase the accuracy of the predicted rate.

**PLANTING RATES FOR (VACUUM) WHEAT 54 CELL DISC
(HALF RATE DRIVE [15 TOOTH])
APPROXIMATE SEEDS/HECTARE FOR 35 CM ROW WIDTH**

Transmission Sprockets		RPM/GS (Seed Disc RPM To Ground Speed (km/h))	81NH2O, no sigulator		81NH2O, sigulator 3.3		Speed Range (km/h)
Drive	Driven		SDS/REV	Population	SDS/REV	Population	
15	28	1.267	909	2,002,809	554	1,219,334	8 to 11
15	27	1.314	903	2,056,694	551	1,252,385	8 to 11
15	26	1.365	897	2,114,134	547	1,287,682	8 to 11
15	25	1.420	891	2,175,483	543	1,325,459	8 to 11
17	28	1.436	888	2,194,326	542	1,337,079	8 to 11
15	24	1.479	883	2,241,141	539	1,365,982	8 to 11
17	27	1.490	882	2,253,208	539	1,373,439	8 to 11
15	23	1.543	876	2,311,561	535	1,409,551	8 to 11
17	26	1.547	875	2,315,865	535	1,412,217	8 to 11
19	28	1.605	868	2,379,026	531	1,451,401	8 to 11
17	25	1.609	868	2,382,650	530	1,453,652	8 to 11
19	27	1.665	861	2,442,390	527	1,490,808	8 to 11
17	24	1.676	860	2,453,973	526	1,498,022	8 to 11
19	26	1.729	854	2,509,686	522	1,532,773	8 to 11
17	23	1.749	852	2,530,278	521	1,545,639	8 to 11
19	25	1.798	846	2,581,265	518	1,577,544	8 to 11
15	19	1.868	838	2,652,284	513	1,622,106	8 to 11
19	24	1.873	837	2,657,522	513	1,625,398	8 to 11
23	28	1.943	829	2,727,970	508	1,669,760	8 to 11
19	23	1.955	828	2,738,889	508	1,676,652	8 to 11
23	27	2.016	821	2,798,761	504	1,714,493	8 to 11
24	28	2.028	819	2,810,944	503	1,722,211	8 to 11
15	17	2.088	813	2,868,489	499	1,758,716	8 to 11
23	26	2.093	812	2,873,613	499	1,761,973	8 to 11
24	27	2.103	811	2,883,270	498	1,768,112	8 to 11
25	28	2.112	810	2,892,214	497	1,773,801	8 to 11
17	19	2.117	809	2,896,445	497	1,776,493	8 to 11
23	25	2.177	803	2,952,842	493	1,812,439	8 to 11
24	26	2.184	802	2,959,650	493	1,816,788	8 to 11
25	27	2.191	801	2,965,945	493	1,820,810	8 to 11
26	28	2.197	801	2,971,782	492	1,824,538	8 to 11
23	24	2.267	793	3,036,784	488	1,866,162	8 to 11
24	25	2.272	792	3,040,388	487	1,868,475	8 to 11
25	26	2.275	792	3,043,713	487	1,870,611	8 to 11
26	27	2.278	792	3,046,790	487	1,872,585	8 to 11
27	28	2.282	791	3,049,644	487	1,874,417	8 to 11
15	15	2.366	782	3,125,801	482	1,923,438	8 to 11
28	27	2.454	772	3,202,977	476	1,973,374	8 to 11
27	26	2.457	772	3,205,909	476	1,975,275	8 to 11
26	25	2.461	772	3,209,073	476	1,977,328	8 to 11
25	24	2.465	771	3,212,494	476	1,979,550	8 to 11
24	23	2.469	771	3,216,212	475	1,981,963	8 to 11
28	26	2.548	762	3,284,041	471	2,026,118	8 to 11
27	25	2.556	762	3,290,206	470	2,030,142	8 to 11
26	24	2.563	761	3,296,872	470	2,034,494	8 to 11
25	23	2.572	760	3,304,099	469	2,039,217	8 to 11
19	17	2.644	752	3,364,614	465	2,078,867	8 to 11
28	25	2.650	752	3,369,203	465	2,081,879	8 to 11
27	24	2.662	750	3,378,927	464	2,088,273	8 to 11
26	23	2.675	749	3,389,458	463	2,095,200	8 to 11
17	15	2.682	748	3,395,059	463	2,098,888	8 to 11
28	24	2.761	740	3,458,662	458	2,140,885	8 to 11

Continued on next page.

**PLANTING RATES FOR (VACUUM) WHEAT 54 CELL DISC
(HALF RATE DRIVE [15 TOOTH])
APPROXIMATE SEEDS/HECTARE FOR 35 CM ROW WIDTH**

Transmission Sprockets		RPM/GS (Seed Disc RPM To Ground Speed (km/h))	8INH2O, no sigulator		8INH2O, sigulator 3.3		Speed Range (km/h)
Drive	Driven		SDS/REV	Population	SDS/REV	Population	
27	23	4.469	738	3,472,292	457	2,149,916	8 to 11
23	19	4.609	729	3,540,088	452	2,195,007	8 to 11
28	23	4.635	728	3,552,602	451	2,203,361	8 to 11
24	19	4.809	717	3,634,408	445	2,258,249	8 to 11
19	15	4.822	716	3,640,562	445	2,262,400	8 to 11
25	19	5.009	704	3,725,023	438	2,319,630	8 to 11
23	17	5.151	695	3,786,759	433	2,361,838	8 to 11
26	19	5.210	692	3,811,937	431	2,379,150	8 to 11
24	17	5.375	682	3,880,734	426	2,426,772	8 to 11
27	19	5.410	680	3,895,152	425	2,436,811	8 to 11
25	17	5.599	668	3,970,088	419	2,489,383	8 to 11
28	19	5.610	668	3,974,663	418	2,492,614	8 to 11
26	17	5.823	655	4,054,817	412	2,549,669	8 to 11
23	15	5.837	654	4,060,299	411	2,553,605	8 to 11
27	17	6.046	642	4,134,920	405	2,607,632	8 to 11
24	15	6.091	640	4,150,387	403	2,618,945	8 to 11
28	17	6.270	630	4,210,402	398	2,663,270	8 to 11
25	15	6.345	625	4,234,536	395	2,681,300	8 to 11
26	15	6.599	611	4,312,743	388	2,740,670	8 to 11
27	15	6.853	598	4,385,013	381	2,797,056	8 to 11
28	15	7.106	584	4,451,343	374	2,850,458	8 to 11

NOTE: The SDS/REV values shown in the table above are examples and not actual predicted results, as they are accurate only under one specific set of conditions (8 INH2O vacuum pressure, target speed of 9.66 km/h, and seed density of 25.88 seeds/gram). Once a different ground speed is used, other than 9.66 km/h, the values in the table will no longer apply.

1. Identify planting parameters and record in Table #1.
2. Weigh small sample of seeds and complete Table #2.
3. Use a device to spin the meter at a constant, measured RPM (Seed Meter Test Stand T4000). Set the RPM to settings in the table below (15, 20, 25, 30) and collect a sample of seed coming out of the meter. It is recommended to start with a Vacuum pressure of 8INH2O and removing the singulator. Increasing the vacuum pressure will increase the SDS/REV while using the singulator will decrease the SDS/REV. Weigh the sample of seed and record the length of time the sample was collected in Table #3.
4. Complete Table #3 for each RPM setting using information from Tables 1 and 2. Variables with the subscript “[RPM]” use the values in the same row in Table #3.
5. Choose the 2 closest populations to your desired target population and add them to Table #4 with their respective seeds per rev.
6. Complete Table #4 and calculate the approximate seeds per rev.
7. Calculate Seed Disc RPM/Ground Speed Ratio in Table #5.
8. Select the closest RPM/GS (Seed Disc RPM to Ground Speed (km/h)) in the rate chart and use that Drive and Driven pair.

Table #1				Table #2	
Target Population [seeds/hectare] (Pop_{TAR})				Number of Seeds (N)	
Ideal Planting Ground Speed [km/h] (GS)				Weight of sample [grams] (W)	
Planter Row Spacing [cm] (RS)				Seeds/ Gram = N/W (SG)	
Table #3					
			$SR_{RPM} = \frac{W_{RPM}}{t_{RPM}} \times \left(\frac{60}{RPM}\right) \times SG$		$Pop_{RPM} = \frac{SR_{RPM} \times RPM \times 60,000}{GS \times RS}$
Vacuum Pressure	Disc RPM	Weight [grams] (W_{RPM})	Time [sec.] (t_{RPM})	Seeds/ Rev (SR_{RPM})	Population (Pop_{RPM})
	15				
Sing. Setting	20				
	25				
	30				
Table #4					
Pop_1		Pop_2		Pop_{TAR}	
SR_1		SR_2			
$SR_{TAR} = \left(\frac{SR_2 - SR_1}{Pop_2 - Pop_1}\right) \times (Pop_{TAR} - Pop_1) + SR_1$					
Table #5					
GS		$RPM_{TAR} = \frac{Pop_{TAR} \times GS \times RS}{60,000 \times SR_{TAR}}$			
RS					
Pop_{TAR}		$\frac{RPM_{Tar}}{GS}$			
SR_{TAR}					

NOTE: Additional worksheets can be found on [page 5-23](#)

Example.

Table #1		Table #2	
Target Population [seeds/hectare] (Pop_{TAR})	3,200,000	Number of Seeds (N)	260
Ideal Planting Ground Speed [km/h] (GS)	10 km/h	Weight of sample [grams] (W)	10
Planter Row Spacing [cm] (RS)	35 cm	Seeds/ Gram = N/W (SG)	26

Table #3					
			$SR_{RPM} = \frac{W_{RPM}}{t_{RPM}} \times \left(\frac{60}{RPM}\right) \times SG$		$Pop_{RPM} = \frac{SR_{RPM} \times RPM \times 60,000}{GS \times RS}$
Vacuum Pressure	Disc RPM	Weight [grams] (W_{RPM})	Time [sec.] (t_{RPM})	Seeds/ Rev (SR_{RPM})	Population (Pop_{RPM})
8	15	$\frac{765}{90.4} \times \left(\frac{60}{15}\right) \times 26 = 880.1$		$\frac{880.1 \times 15 \times 60,000}{10 \times 35} = 2,263,114.3$	
		765	90.4	880.1	2,263,114.3
Sing. Setting	20	$\frac{640}{60.5} \times \left(\frac{60}{20}\right) \times 26 = 825.1$		$\frac{825.1 \times 20 \times 60,000}{10 \times 35} = 2,828,914.3$	
		640	60.5	825.1	2,828,914.3
removed	25	$\frac{1101}{90.1} \times \left(\frac{60}{25}\right) \times 26 = 762.5$		$\frac{762.5 \times 25 \times 60,000}{10 \times 35} = 3,267,857.1$	
		1101	90.1	762.5	3,267,857.1
removed	30	$\frac{840}{60.6} \times \left(\frac{60}{30}\right) \times 26 = 720.8$		$\frac{720.8 \times 30 \times 60,000}{10 \times 35} = 3,706,971.4$	
		840	60.6	720.8	3,706,971.4

Table #4					
<i>Pop₁</i>	3,267,857.1	<i>Pop₂</i>	3,706,971.4	<i>Pop_{TAR}</i>	3,200,000
<i>SR₁</i>	762.5	<i>SR₂</i>	720.8		
$SR_{TAR} = \left(\frac{SR_2 - SR_1}{Pop_2 - Pop_1}\right) \times (Pop_{TAR} - Pop_1) + SR_1$					768.9
$\left(\frac{720.8 - 762.5}{3,706,971.4 - 3,267,857.1}\right) \times (3,200,000 - 3,267,857.1) + 762.5 = 768.9$					

Table #5			
GS	10 km/h	$RPM_{TAR} = \frac{Pop_{TAR} \times GS \times RS}{60,000 \times SR_{TAR}}$	24.3
RS	35 cm		
<i>Pop_{TAR}</i>	3,200,000		
<i>SR_{TAR}</i>	768.9	$\frac{3,200,000 \times 10 \times 35}{60,000 \times 768.9} = 24.3$	
		$\frac{RPM_{Tar}}{GS} = \frac{24.3}{10} = 2.43$	2.43

Additional Worksheet

Table #1		Table #2	
Target Population [seeds/hectare] (Pop_{TAR})		Number of Seeds (N)	
Ideal Planting Ground Speed [km/h] (GS)		Weight of sample [grams] (W)	
Planter Row Spacing [cm] (RS)		Seeds/ Gram = N/W (SG)	

Table #3					
				$SR_{RPM} = \frac{W_{RPM}}{t_{RPM}} \times \left(\frac{60}{RPM}\right) \times SG$	$Pop_{RPM} = \frac{SR_{RPM} \times RPM \times 60,000}{GS \times RS}$
Vacuum Pressure	Disc RPM	Weight [grams] (W_{RPM})	Time [sec.] (t_{RPM})	Seeds/ Rev (SR_{RPM})	Population (Pop_{RPM})
	15				
Sing. Setting	20				
	25				
	30				

Table #4				
Pop₁		Pop₂		Pop_{TAR}
SR₁		SR₂		
$SR_{TAR} = \left(\frac{SR_2 - SR_1}{Pop_2 - Pop_1}\right) \times (Pop_{TAR} - Pop_1) + SR_1$				

Table #5			
GS		$RPM_{TAR} = \frac{Pop_{TAR} \times GS \times RS}{60,000 \times SR_{TAR}}$	
RS			
Pop _{TAR}			
SR _{TAR}			
		$\frac{RPM_{Tar}}{GS}$	

**PLANTING RATES FOR (VACUUM) WHEAT 231 CELL DISC
(HALF RATE DRIVE [44 TOOTH])
APPROXIMATE SEEDS/HECTARE FOR 35 CM ROW WIDTH**

Transmission Sprockets		Population	Speed Range (km/h)
Drive	Driven		
15	28	1,358,070	5 to 11
15	27	1,408,357	5 to 11
15	26	1,462,522	5 to 11
15	25	1,521,024	5 to 11
17	28	1,539,131	5 to 11
15	24	1,584,396	5 to 11
17	27	1,596,149	5 to 11
15	23	1,653,282	5 to 11
17	26	1,657,523	5 to 11
19	28	1,720,209	5 to 11
17	25	1,723,823	5 to 11
19	27	1,783,923	5 to 11
17	24	1,795,658	5 to 11
19	26	1,852,525	5 to 11
17	23	1,873,732	5 to 11
19	25	1,926,642	5 to 11
15	19	2,001,350	5 to 11
19	24	2,006,902	5 to 11
23	28	2,082,351	5 to 11
19	23	2,094,162	5 to 11
23	27	2,159,491	5 to 11
24	28	2,172,901	5 to 11
15	17	2,236,805	5 to 11
24	27	2,253,371	5 to 11
17	19	2,268,206	5 to 11
23	25	2,332,241	5 to 11
26	28	2,353,982	5 to 11
23	24	2,429,428	5 to 11
24	25	2,433,651	5 to 11
27	28	2,444,512	5 to 11
23	23	2,535,043	5 to 11
28	27	2,628,940	5 to 11
27	26	2,632,553	5 to 11
24	23	2,647,746	5 to 11
28	26	2,730,044	5 to 11
27	25	2,737,862	5 to 11
25	23	2,755,492	5 to 11
19	17	2,833,280	5 to 11
27	24	2,851,936	5 to 11
26	23	2,865,706	5 to 11
28	24	2,957,551	5 to 11
27	23	2,975,923	5 to 11
23	19	3,068,735	5 to 11
28	23	3,086,137	5 to 11
24	19	3,202,172	5 to 11
25	19	3,335,589	5 to 11
23	17	3,429,773	5 to 11
26	19	3,469,009	5 to 11
24	17	3,578,902	5 to 11
27	19	3,602,446	5 to 11
25	17	3,728,011	5 to 11
28	19	3,735,865	5 to 11
26	17	3,877,137	5 to 11
23	15	3,887,066	5 to 11
27	17	4,026,246	5 to 11

LUBRICATION

Following pages show locations of all lubrication points. Proper lubrication of moving parts helps ensure efficient operation of your Kinze planter and prolongs the life of friction producing parts.

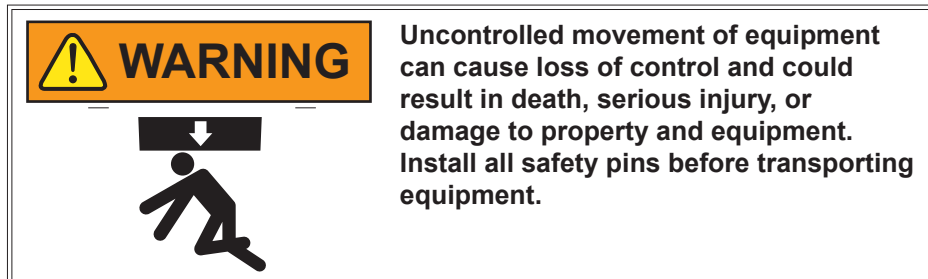

Lubrication Symbols



Lubricate at frequency indicated with SAE multipurpose grease.



Lubricate at frequency indicated with high quality SAE 10 weight oil or spray lubricant.

SEALED BEARINGS

Sealed bearings are used on your Kinze planter to provide trouble free operation.

These are located on drive shafts, row units, and transmission bearings. Sealed bearings are lubricated for life and are not serviceable.

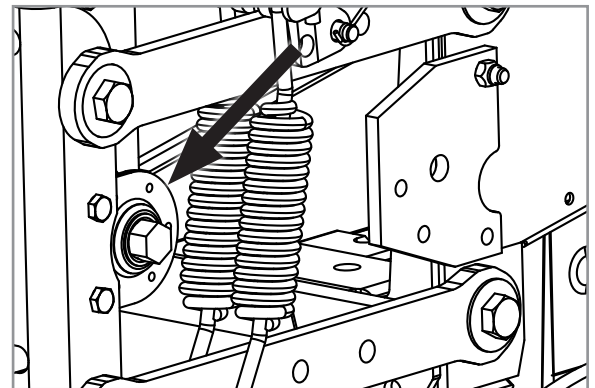

Sealed bearing (Typical)

WRAP SPRING WRENCH ASSEMBLY

1. Remove 1/4"-20 x 1/2" cap screw securing idler assembly to wrap spring wrench tightener shaft and
2. Remove wrap spring wrench from planter.
3. Tip wrap spring wrench on its side and lubricate with a high quality spray lubricant. Lubricant must be absorbed into wrap spring area.
4. Reinstall wrap spring wrench on planter.



Wrap spring wrench lubrication

DRIVE CHAINS

Lubricate all transmission and drive chains daily with a high quality chain lubricant. Extreme operating conditions such as dirt, temperature, or speed may require more frequent lubrication. If a chain becomes stiff, it should be removed, soaked, and washed in solvent to loosen and remove dirt from joints. Soak chain in oil so lubricant can penetrate between rollers and bushings.

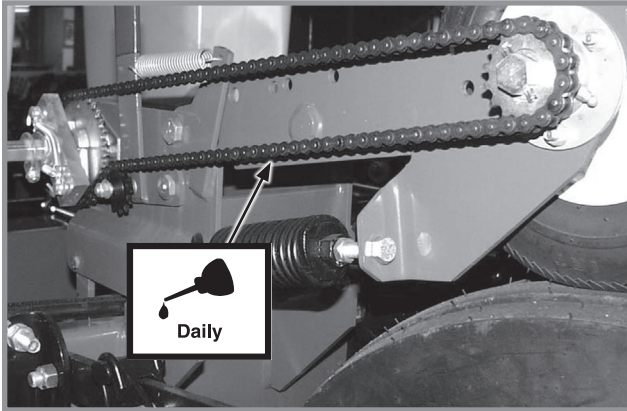

Contact Wheel Drive Chain

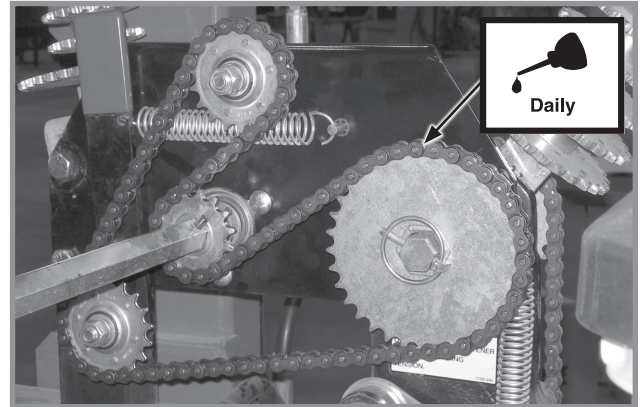

Reverser Plate Chain Drive

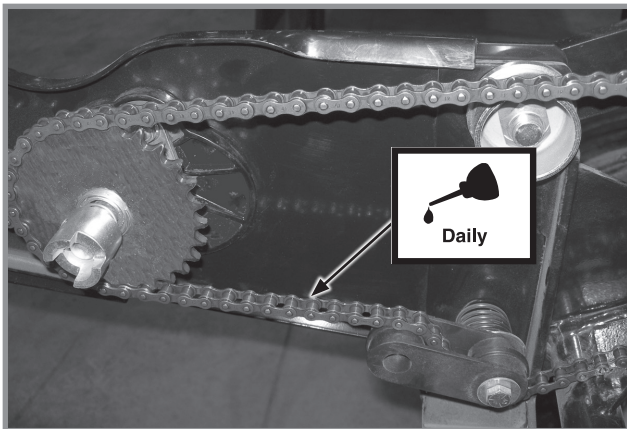

Pull Row Unit Drive Chain

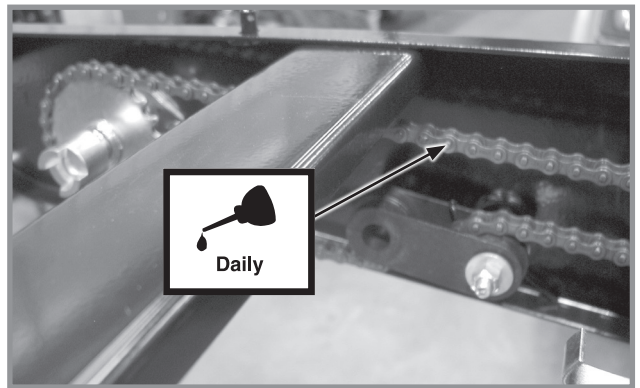

Row Unit Granular Chemical Drive Chains

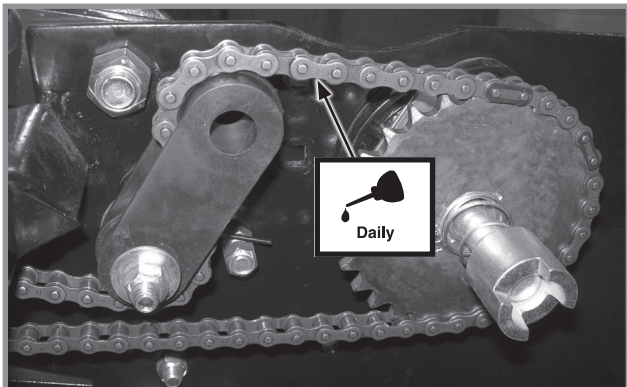

Push Row Unit Drive Chains

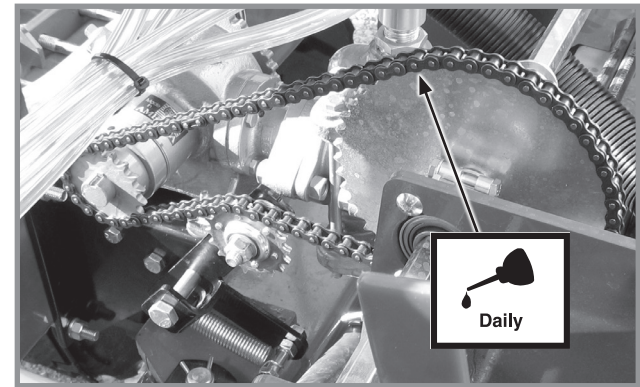

Liquid Fertilizer Piston Pump Drive Chain

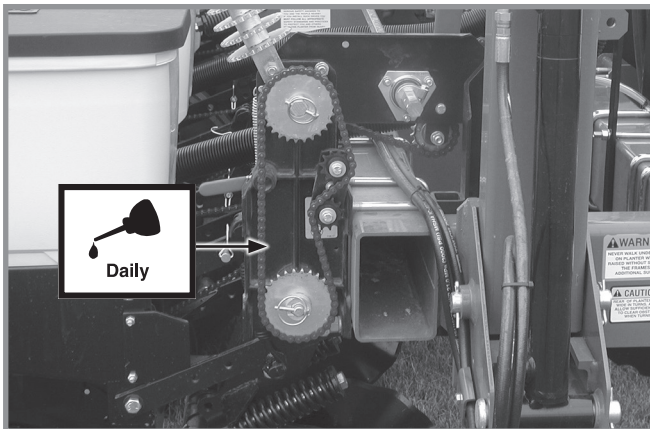

Planter Seed Rate Transmission Drive Chain

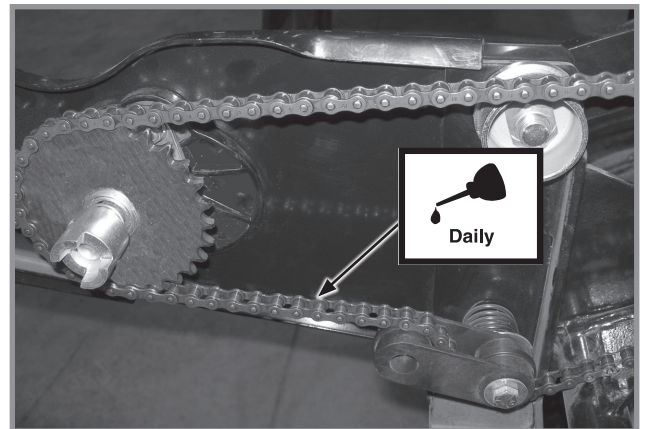

Pull Row Unit Drive Chain

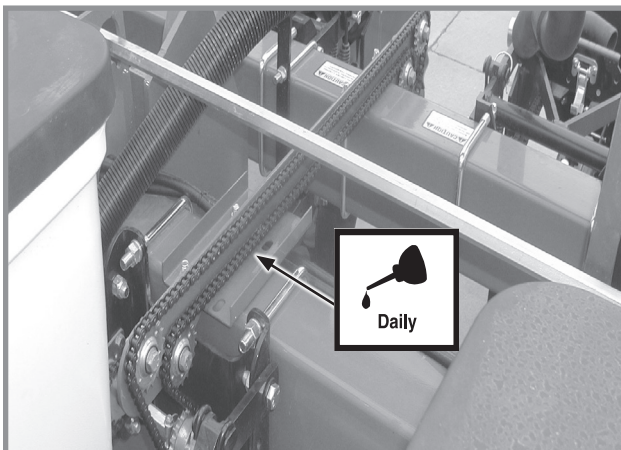

Split Row Package Drive Chain

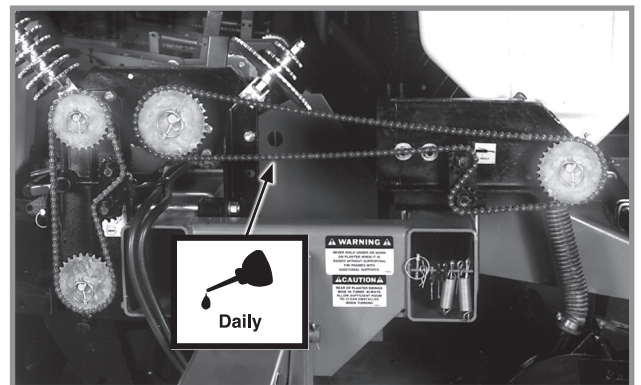

Dry Fertilizer Drive Chain

SPLIT ROW PUSH UNIT LOCKUPS

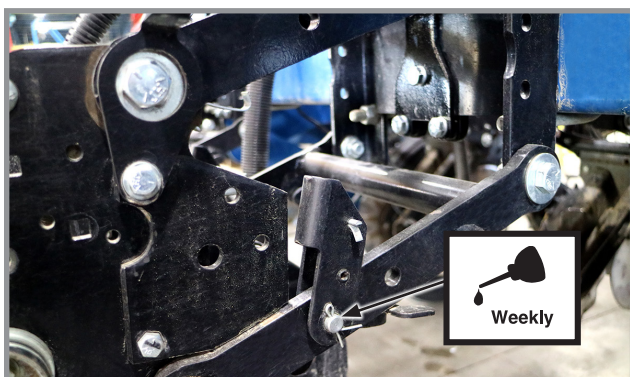

2 Per Row

BUSHINGS

Lubricate bushings at frequency indicated.

Check each bolt for proper torque. If bolt is loose, removed it and inspect bushing for cracks and wear. Replace bushing if necessary. Use **only hardened flat washers**. Replace damaged flat washers with proper part. Torque hardware to 130 ft-lb (~176 Nm).

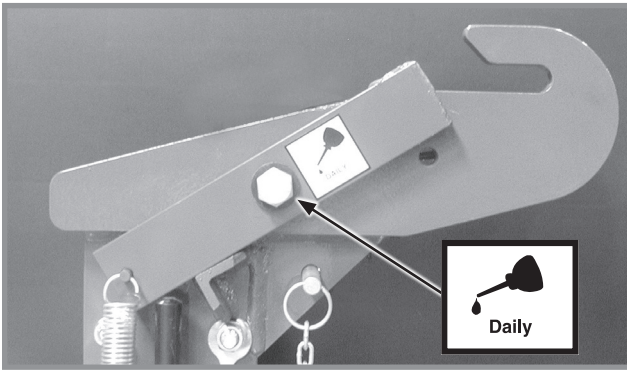

Transport Catch Pivot

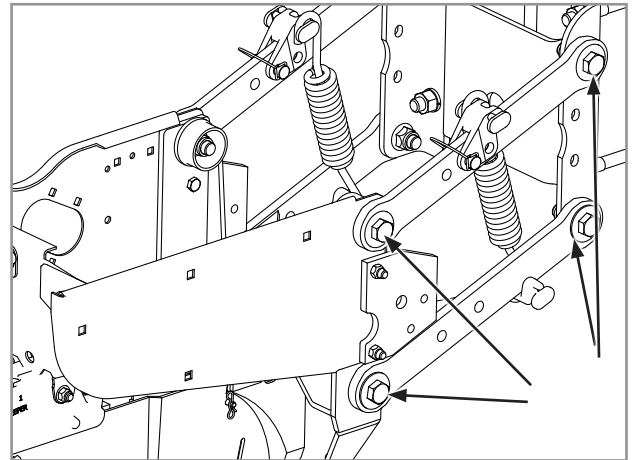

Pull Row Unit And/Or Push Row Unit Parallel Linkages (8 Per Row)

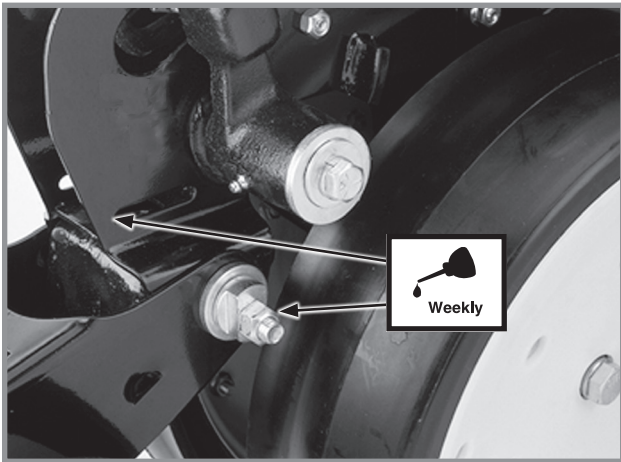

Row Unit "V" Closing Wheel, Covering Discs/ Single Press Wheel And/Or Drag Closing Wheel Eccentric Bushings (2 Per Row)

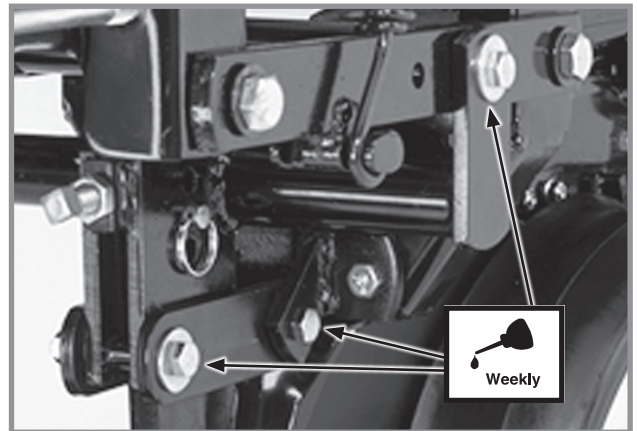

Row Unit Mounted Disc Furrower Parallel Linkages (6 Per Row)

GREASE FITTINGS

Lubricate parts with grease fittings at frequency indicated with an SAE multipurpose grease. Clean fitting thoroughly before using grease gun. Frequency of lubrication recommended is based on normal operating conditions. Severe or unusual conditions may require more frequent attention.

BASE MACHINE

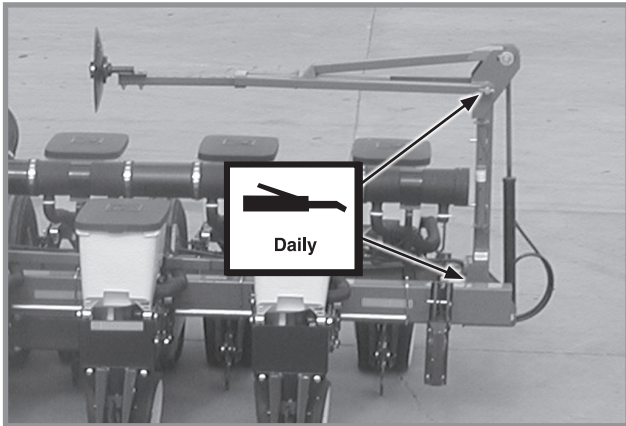

Row marker assembly - 2 per assembly

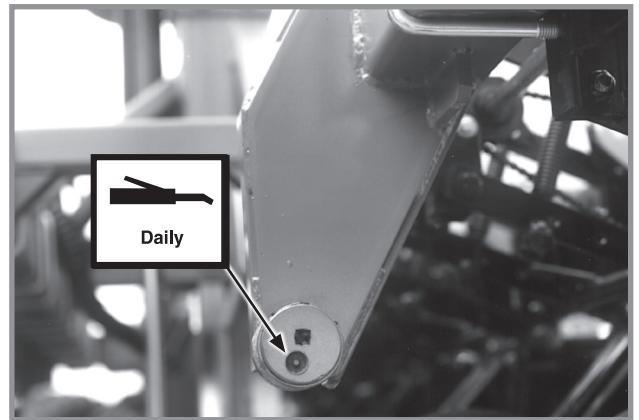

Cam follower - 1 per cam follower

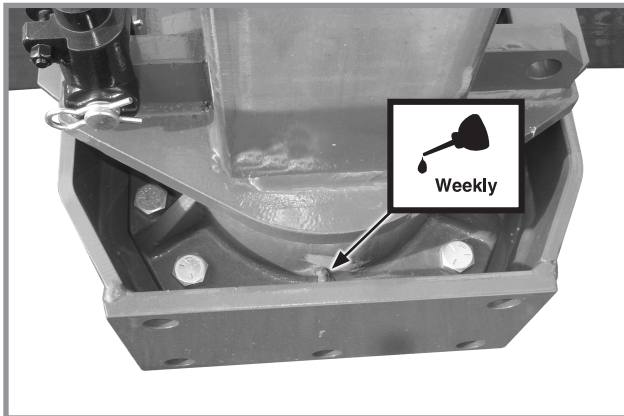

Center Pivot - 1

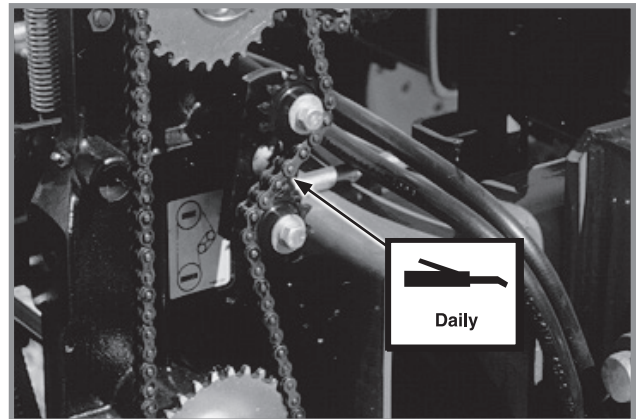

Seed rate transmission assembly - 1 (Idler)

ROW UNIT

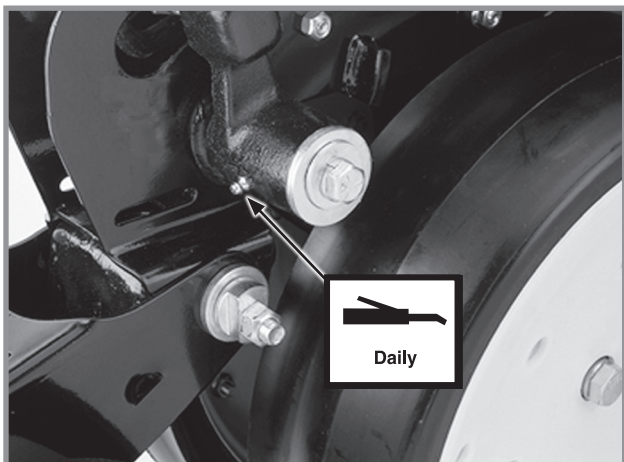

Gauge wheel arms - 1 per arm

NOTE: Seals in gauge wheel arm are installed with lip facing out to allow grease to purge dirt away from seal. Pump grease into arm until fresh grease appears between washers and arm.)

DRY FERTILIZER ATTACHMENT

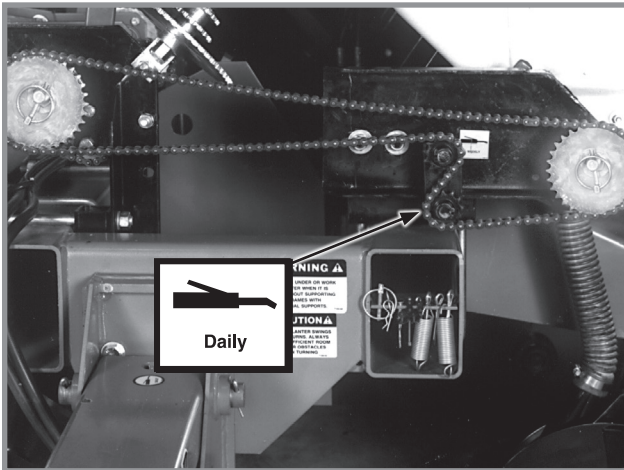

Fertilizer transmission - 1 per transmission (Idler)

FERTILIZER OPENERS

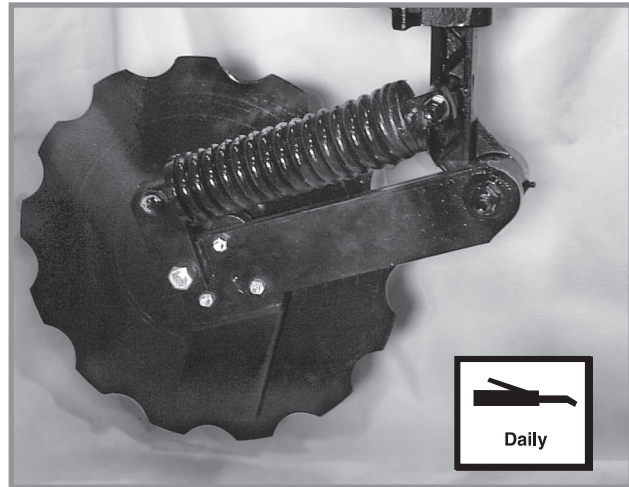

Notched Single Disc Fertilizer Opener - 1

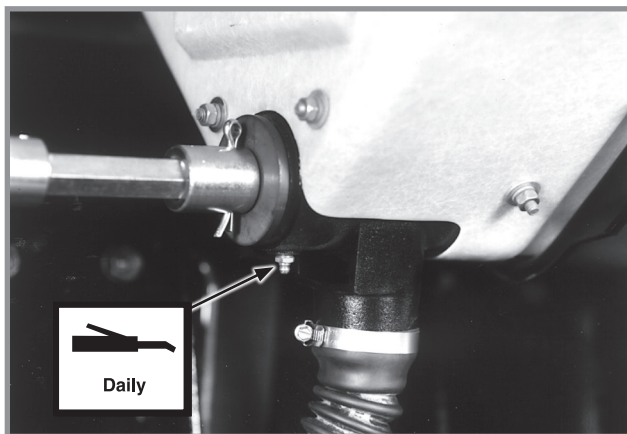

Fertilizer hopper - 4 per hopper

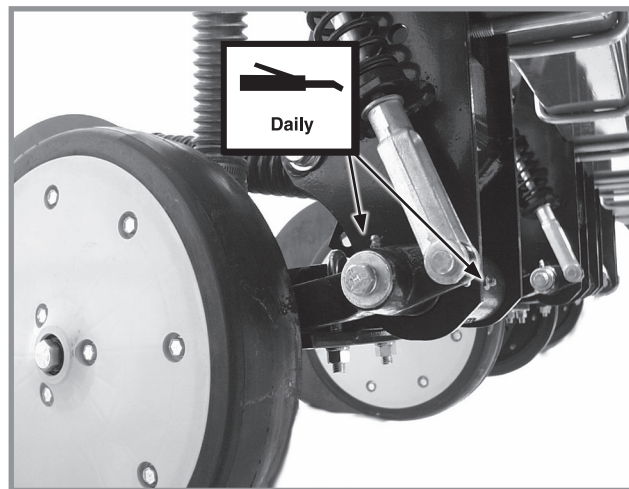

HD Single Disc Fertilizer Opener - 2
(Located On Wheel Arm And Opener Mount)

LIQUID FERTILIZER PISTON PUMP

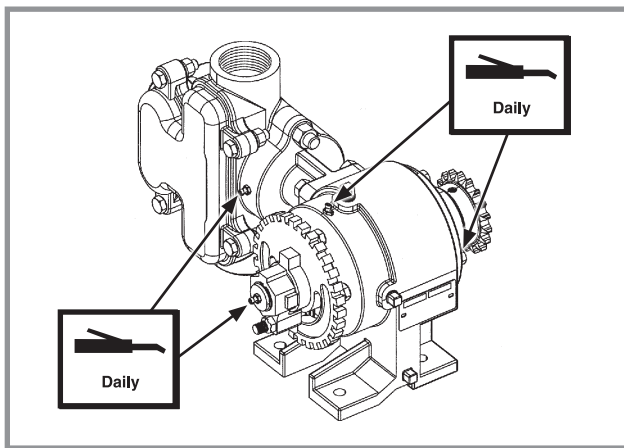

Liquid Fertilizer Piston Pump - 4

NOTE: Fill on outboard stuffing box until lubricant seeps out of drain hole in bottom.

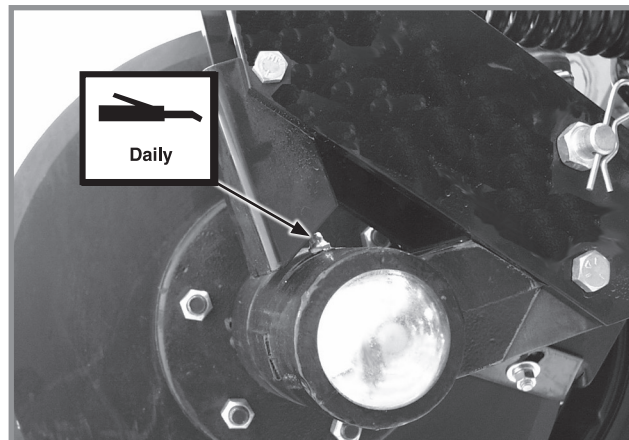

HD Single Disc Fertilizer Opener - 1
(Located On Disc Opener Spindle Hub)

PTO PUMP SHAFT AND TRACTOR PTO SHAFT

Lubricate the PTO Pump Shaft and the Tractor PTO Shaft with the LM 47 Long-Life Grease provided with the PTO Pump Mount Assembly kit once a week. The frequency of lubrication is based on normal operating conditions. Severe or unusual conditions may require more frequent attention.

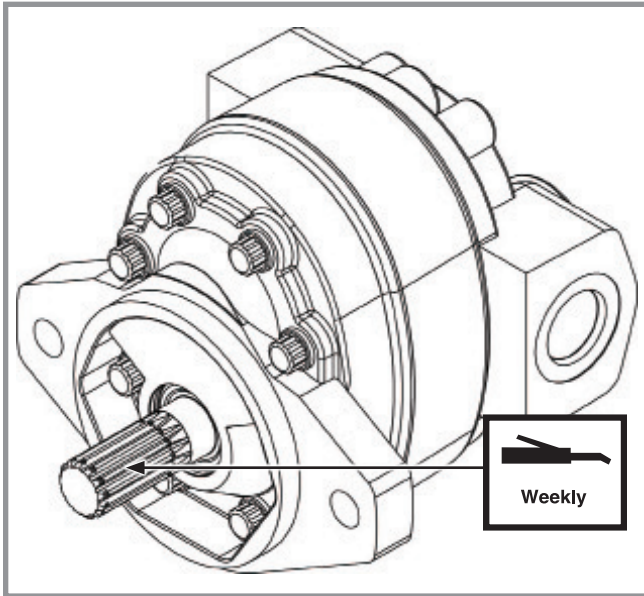

PTO Pump

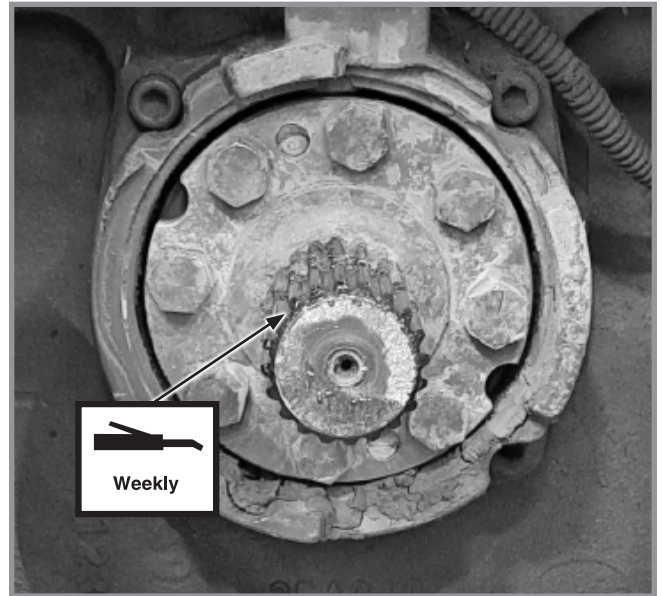

Tractor PTO Shaft

Lubricate the chain installed on the sprockets with a spray lube for chains once a day.

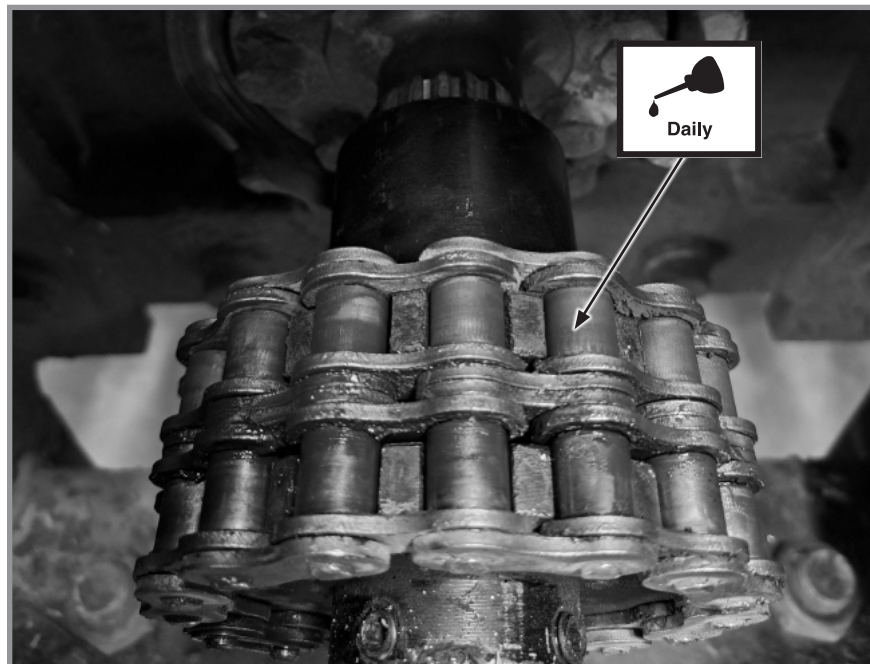

Chain

This page left blank intentionally.

CENTER POST

NOTICE

Any oil or grease on center post and poly wear pads will attract dirt and accelerate wear. Do not lubricate center post and poly wear pads.

Center post is clad with stainless steel. Keep stainless steel surface clean and free of any lubrication to prolong service life.

See ["Wear Pad Adjustment/Replacement" on page 6-23](#) for more information.



Center post

WHEEL BEARINGS

All drive, transport, and marker hub wheel bearings should be repacked annually and checked for wear.

1. Raise wheel off ground.
2. Check for bearing endplay by moving wheel side to side.
3. Rotate wheel to check for bearing roughness. If bearings sound rough, remove hub and inspect bearings.

NOTE: To repack wheel hubs, follow procedure outlined for wheel bearing replacement with exception that bearings and bearing cups are reused.

LIQUID FERTILIZER PISTON PUMP CRANKCASE OIL LEVEL

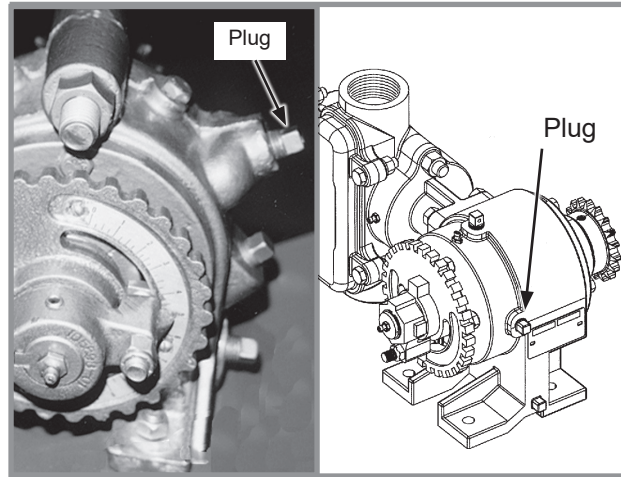

Piston pump oil fill plug location

Check crankcase oil daily and maintain at plug level. Fill as needed with EP 90W gear oil. Total oil capacity is approximately $\frac{3}{4}$ pint.

Refer to operator and instruction manual supplied with pump and flow divider for more information.

PTO PUMP SHAFT COUPLING (PTO PUMP DRIVE AND OIL COOLER OPTION)

NOTE: Clean and grease PTO shaft coupling each time pump is installed.

NOTE: Apply coating of high-speed industrial coupling grease, such as Chevron® Coupling Grease, that meets AGMA CG-1 and CG-2 Standards to extend shaft spline life.

Chevron® trademark is owned by Chevron Products Company. AGMA is the acronym for the American Gear Manufacturers Association.

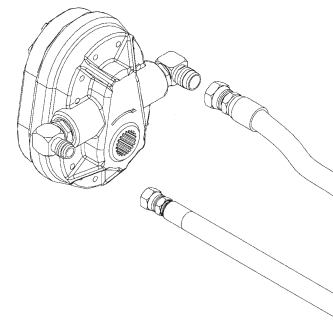

1 $\frac{3}{8}$ "-21 spline PTO pump shown

MOUNTING BOLTS AND HARDWARE

Before operating planter for the first time, check all hardware is tight. Check all hardware again after first 50 hours of operation and beginning of each planting season.

All hardware used on the Kinze planter is Grade 5 (high strength) unless otherwise noted. Grade 5 cap screws are marked with three radial lines on the head. Hardware must be replaced with equal size, strength, and thread type.



WARNING



Loose transport wheel lug bolts can result in wheel separation from planter and result in death, serious injury, and damage to property and equipment. Check transport wheel lug nut torque before operating planter for the first time and periodically thereafter.



NOTICE

Over-tightening hardware can reduce its shock load capacity and cause equipment failure.

TORQUE VALUES CHART - PLATED HARDWARE

Diameter	Grade 2 (No marks) 		Grade 5 (3 marks) 		Grade 8 (6 marks) 	
	Coarse	Fine	Coarse	Fine	Coarse	Fine
1/4"	50 in-lb	56 in-lb	76 in-lb	87 in-lb	9 ft-lb (~12 Nm)	10 ft-lb (~14 Nm)
5/16"	8 ft-lb (~11 Nm)	9 ft-lb (~12 Nm)	13 ft-lb (~18 Nm)	14 ft-lb (~19 Nm)	18 ft-lb (~24 Nm)	20 ft-lb (~27 Nm)
3/8"	15 ft-lb (~20 Nm)	17 ft-lb (~23 Nm)	23 ft-lb (~31 Nm)	26 ft-lb (~35 Nm)	33 ft-lb (~45 Nm)	37 ft-lb (~50 Nm)
7/16"	25 ft-lb (~34 Nm)	27 ft-lb (~37 Nm)	37 ft-lb (~50 Nm)	41 ft-lb (~56 Nm)	52 ft-lb (~71 Nm)	58 ft-lb (~79 Nm)
1/2"	35 ft-lb (~48 Nm)	40 ft-lb (~54 Nm)	57 ft-lb (~77 Nm)	64 ft-lb (~87 Nm)	80 ft-lb (~108 Nm)	90 ft-lb (~122 Nm)
9/16"	50 ft-lb (~68 Nm)	60 ft-lb (~81 Nm)	80 ft-lb (~108 Nm)	90 ft-lb (~122 Nm)	115 ft-lb (~156 Nm)	130 ft-lb (~176 Nm)
5/8"	70 ft-lb (~95 Nm)	80 ft-lb (~108 Nm)	110 ft-lb (~149 Nm)	125 ft-lb (~169 Nm)	160 ft-lb (~217 Nm)	180 ft-lb (~244 Nm)
3/4"	130 ft-lb (~176 Nm)	145 ft-lb (~197 Nm)	200 ft-lb (~271 Nm)	220 ft-lb (~298 Nm)	280 ft-lb (~380 Nm)	315 ft-lb (~427 Nm)
7/8"	125 ft-lb (~169 Nm)	140 ft-lb (~190 Nm)	320 ft-lb (~434 Nm)	350 ft-lb (~475 Nm)	450 ft-lb (~610 Nm)	500 ft-lb (~678 Nm)
1"	190 ft-lb (~258 Nm)	205 ft-lb (~278 Nm)	480 ft-lb (~651 Nm)	530 ft-lb (~719 Nm)	675 ft-lb (~915 Nm)	750 ft-lb (~1017 Nm)
1 1/8"	265 ft-lb (~359 Nm)	300 ft-lb (~407 Nm)	600 ft-lb (~814 Nm)	670 ft-lb (~908 Nm)	960 ft-lb (~1302 Nm)	1075 ft-lb (~1458 Nm)
1 1/4"	375 ft-lb (~508 Nm)	415 ft-lb (~563 Nm)	840 ft-lb (~1139 Nm)	930 ft-lb (~1261 Nm)	1360 ft-lb (~1844 Nm)	1500 ft-lb (~2034 Nm)
1 3/8"	490 ft-lb (~664 Nm)	560 ft-lb (~759 Nm)	1100 ft-lb (~1491 Nm)	1250 ft-lb (~1695 Nm)	1780 ft-lb (~2413 Nm)	2030 ft-lb (~2752 Nm)
1 1/2"	650 ft-lb (~881 Nm)	730 ft-lb (~990 Nm)	1450 ft-lb (~1966 Nm)	1650 ft-lb (~2237 Nm)	2307 ft-lb (~3128 Nm)	2670 ft-lb (~3620 Nm)

NOTE: Torque unplated hardware and bolts with lock nuts approximately 1/3 higher than above values. Torque bolts lubricated prior to installation to 70% of value shown in chart.

TORQUE VALUES - WHEEL LUG NUTS

Lug Nut Size	Torque Value	Interval
5/8" - 18 Wheel Lug Nuts and Lug Bolts	200 ft-lb (270 Nm)	<ul style="list-style-type: none"> Once before first planting; Again after first 50 km or 10 operational hours; Periodically thereafter (at least once before every planting season).
3/8" - 18 Wheel Lug Nuts and Lug Bolts	125 ft-lb (170 Nm)	<ul style="list-style-type: none"> Once before first planting; Again after first 50 km or 10 operational hours; Periodically thereafter (at least once before every planting season).

Cylinder Rod Piston Retaining Nut Torque Chart

	Non-Nylock Nut	Nylock Nut
1/2"-20	55-70 ft-lb (~75-95 Nm)	45-55 ft-lb (~61-75 Nm)
3/4"-16	115-125 ft-lb (~156-169 Nm)	100-115 ft-lb (~136-156 Nm)
7/8"-14	150-180 ft-lb (~203-244 Nm)	130-150 ft-lb (~176-203 Nm)
1"-14	275-330 ft-lb (~373-447 Nm)	250-275 ft-lb (~339-373 Nm)
1 1/8"-12	300-375 ft-lb (~407-508 Nm)	275-300 ft-lb (~373-407 Nm)
1 1/4"-12	300-375 ft-lb (~407-508 Nm)	275-300 ft-lb (~373-407 Nm)

Torque Values - Pneumatic Down Pressure

Diameter	Torque Value
1/8" NPT	120 in-lb Maximum
1/2"-13	180 in-lb Maximum
3/4"-16	180 in-lb Maximum

NOTE: Use these torque values with pneumatic down pressure components.

Special Torque Values & Instructions

Row unit parallel linkage bushing hardware	130 ft-lb (~176 Nm)
5/8" No till coulter spindle hardware	120 ft-lb (~162 Nm)
Vacuum fan impeller assembly to motor shaft 5/8"-18 hex jam nut (8 Row Only)	50 ft-lb (~68 Nm)

TIRE PRESSURE

WARNING

Explosive separation of rim and tire parts can cause death or serious injury. Overinflation, rim and tire servicing, improper use of rims and tires, or worn or improperly maintained tires could result in a tire explosion.



To prevent tire explosions:

- Maintain proper tire pressure. Inflating a tire above or below the recommended pressure can cause tire damage.
- Mount tires only by properly trained personnel using proper equipment.
- Replace tires with cuts or bubbles. Replace damaged rims. Replace missing lug bolts and nuts.
- Do not weld or heat wheel assembly. Heating increases tire pressure.

CHAIN TENSION ADJUSTMENT

Drive chains are equipped with spring loaded idlers and are self-adjusting. The only adjustment needed is to shorten the chains if wear stretches the chains and reduces spring tension. The pivot point of these idlers should be checked periodically to ensure they rotate freely. See [“Wrap Spring Wrench Assembly” on page 6-1](#) for more information.

Additional chain links can be found in the storage area located inside the front planter frame.

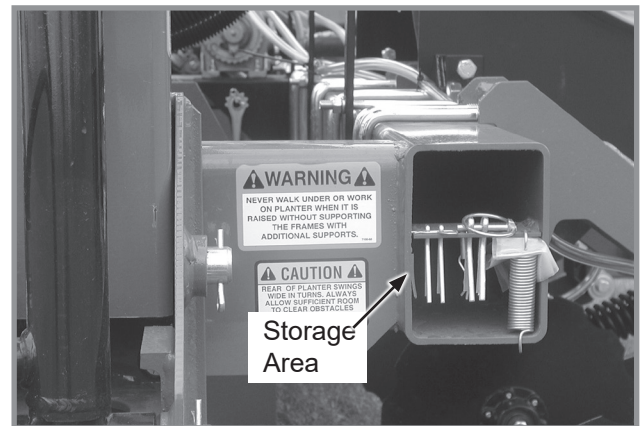

Spare chain link storage

PNEUMATIC DOWN PRESSURE AIR COMPRESSOR TANK

Moisture should be drained daily from the tank. Tank should be drained completely for storage.

To drain tank, locate drain plug on the bottom of tank. Stand off to the side of tank and pull cable attached to drain.

NOTE: If moisture is not drained from tank rust particles will form inside tank.

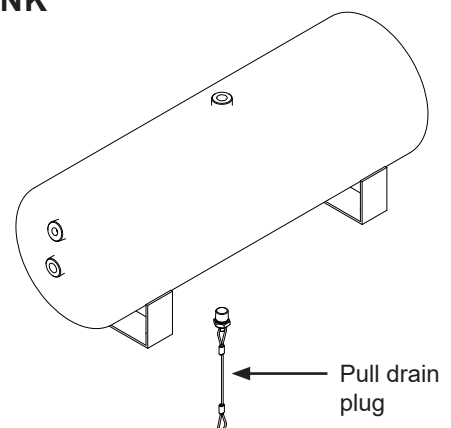

VACUUM SEED METER MAINTENANCE

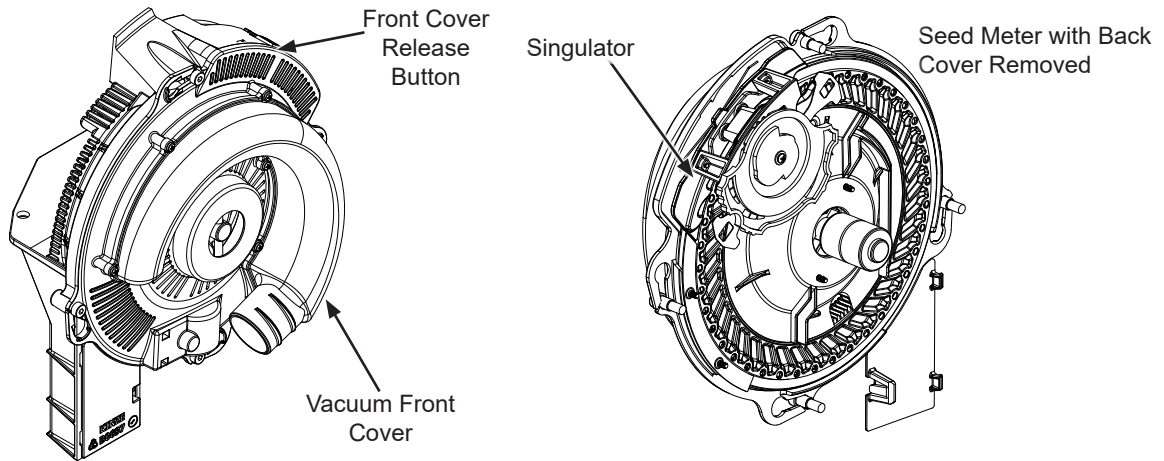

Before each planting season inspect seed discs and singulator and clean or replace as needed.

Use clean, high quality seed for maximum meter accuracy. Damaged or cracked seed, hulls, and foreign material may become lodged in seed disc orifices and greatly reduce meter accuracy.

Inspect and clean seed discs daily checking for any buildup of foreign material and blocked orifices. If seed disc orifices are plugged frequently with seed remnants, remnants ejector wheel may need to be replaced. Clean seed disc by washing it with soap and water. Dry thoroughly.

Inspect singulator blades and guide for wear after every 200 acres (~81 hectares) per row of operation. If adjustment of singulator blade does not affect meter performance or if blades appear worn, singulator blade may need to be replaced.

Replace seed disc or vacuum seal if abnormally high vacuum is required or if consistent operation cannot be achieved.

See [“Preparing Planter for Storage” on page 6-30](#) for additional Vacuum Seed Metering System maintenance.

SEED METER CLEANOUT

NOTE: Use of damaged seed or seed containing foreign material will cause plugging of seed cell orifices and require more frequent seed meter cleanout to prevent underplanting.

Thorough seed meter cleanout is important to maintain genetic purity.

1. Disengage seed drive and remove seed hopper and meter.
2. Dump seed from right rear corner of hopper into a container.
3. Lay hopper on its right side. Push release button and rotate seed meter vacuum cover clockwise to align keyhole slots with bolt heads. Lift off cover.
4. Rotate seed disc hub clockwise to unlock and remove seed disc.
5. Empty meter.
6. Thoroughly inspect meter to ensure all seed is removed.
7. Replace seed disc. Install vacuum cover.

GAUGE WHEEL ADJUSTMENT

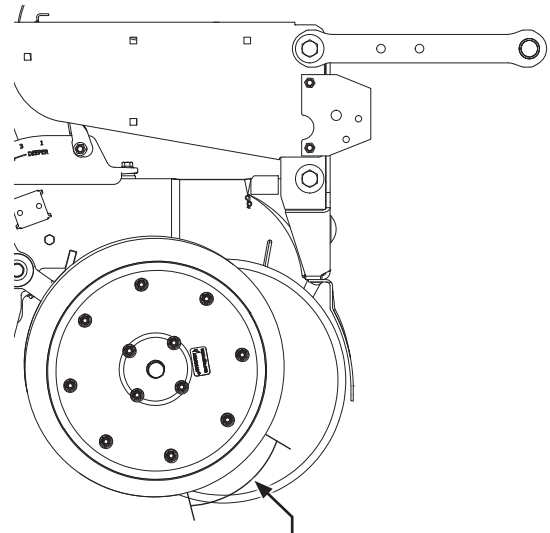
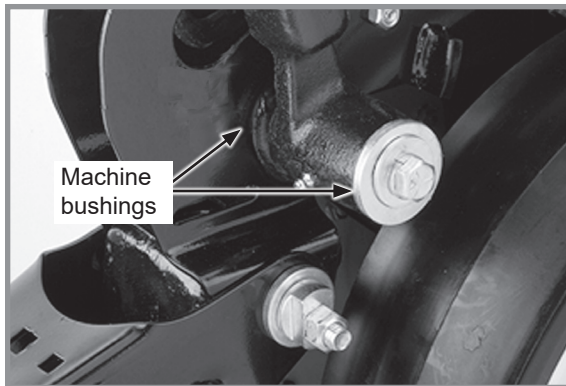

Shim gauge wheel to lightly contact opener disc blade in this area for 4" to 6" (10-15 cm). Check adjustment in operating position.

NOTE: It may be desirable to space gauge wheel further from blade when operating in sticky soils.

NOTE: Set depth adjustment handle at 3x2 position and lift gauge wheel to stop one side at a time.

Gauge wheels should lightly contact opener blades to prevent accumulation of dirt or trash. Gauge wheels and opener blades should turn with only slight resistance.

Add or remove machine bushings between shank and gauge wheel arm to adjust clearance between gauge wheels and opener blades. Store remaining machine bushings between gauge wheel arm and flat washer on outer side of gauge wheel arm.

Contact should be no less than one half of the rotation of the wheel, while not sticking in any position (it does not have to be continuous) Wheel should rotate in the direction of travel of the row unit. Wheel can be held in position by supporting the spindle bolt head.

GAUGE WHEEL ARM BUSHING/SEAL REPLACEMENT

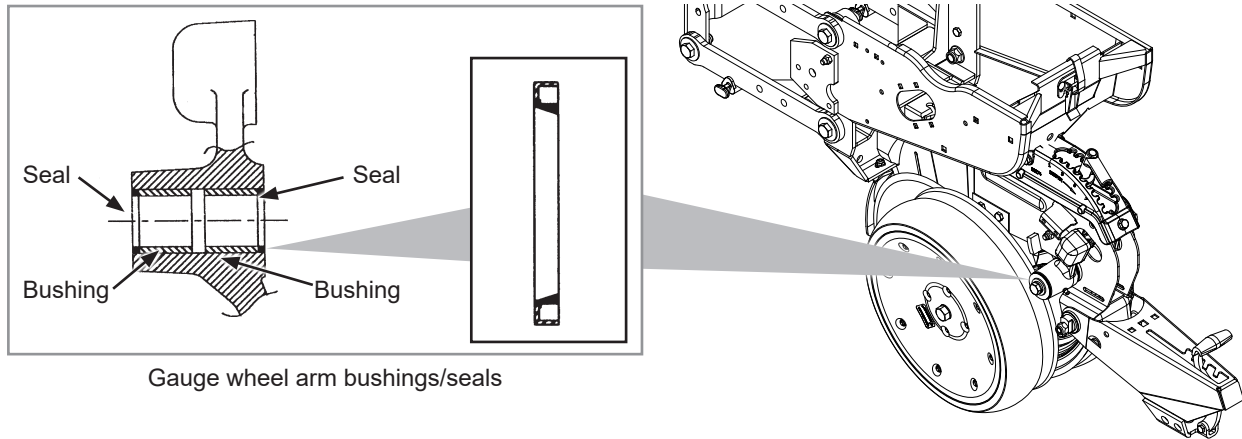

Gauge wheel arm bushings/seals

NOTE: Gauge Wheel Arm Bushing and Seal Driver Kit (G1K296) is available through your Kinze Dealer.

1. Remove gauge wheel from arm.
2. Remove gauge wheel arm from shank assembly.
3. Remove seal and bushing and discard. Clean and dry inner bore.
4. Drive/press replacement bushing inside bore of arm to a depth of .125" below flush.
5. Coat wiping edge of seal with grease.
6. Drive/press seal into place with lip to outside.

NOTE: Use extra care to protect the sealing lip during installation. Apply uniform pressure to assemble the seal into the bore of the arm. Never apply a direct hammer blow to the seal surface.

7. Inspect gauge wheel pivot spindle.
8. Reinstall gauge wheel arm assembly and gauge wheel.

NOTE: Use special machine bushing between gauge wheel arm and gauge wheel.

9. Shim for proper gauge wheel tire/disc blade clearance.
10. Lubricate with an SAE multipurpose grease.

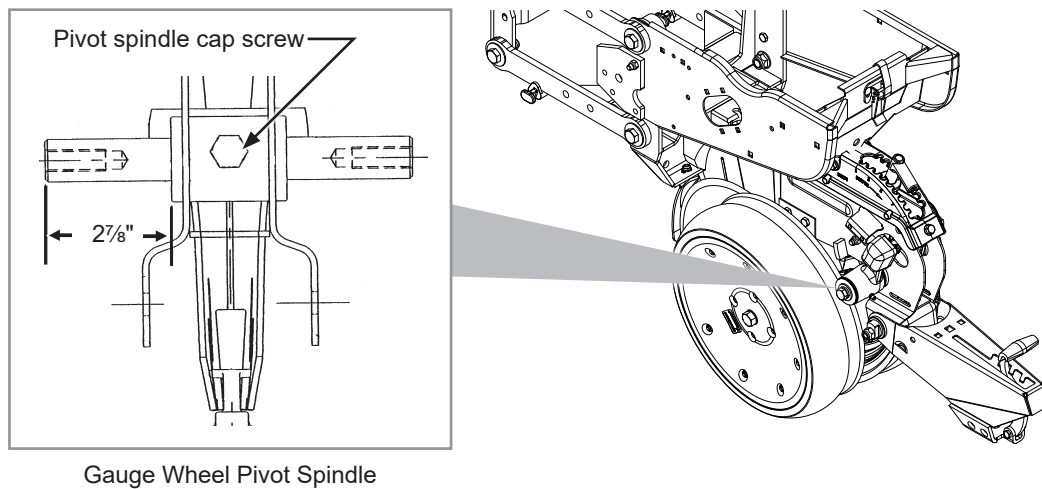
GAUGE WHEEL ARM PIVOT SPINDLE REPLACEMENT

1. Remove gauge wheel and arm assemblies from shank assembly.
2. Remove $\frac{1}{2}$ " x $\frac{3}{4}$ " cap screw that locks pivot spindle in place and remove spindle.
3. Install replacement spindle and position as shown. Exact centering is critical.
4. Install $\frac{1}{2}$ " x $\frac{3}{4}$ " cap screw and torque to lock pivot spindle in place.
5. Install gauge wheel and arm assemblies. Shim for proper gauge wheel tire/disc blade clearance.

15" SEED OPENER DISC BLADE/BEARING ASSEMBLY

NOTICE

Excessive blade contact may result in premature disc opener bearing/hub failures and excessive wear on seed tube guard/inner scraper. When properly adjusted, if one blade is held in fixed position, opposite blade should rotate with less than 5 pounds force (~22 N) at outer edge of blade.

Maintain approximately $1" \pm \frac{1}{2}"$ (~2.5 ± 1 cm) of blade-to-blade contact to properly open and form seed trench. As blade diameter decreases due to wear, it is necessary to relocate machine bushings from inside to outside to maintain $1" \pm \frac{1}{2}"$ (~2,5 ± 1 cm) of contact.

NOTE: Proper blade clearance is critical. Blades should have $1" \pm \frac{1}{2}"$ (~2,5 ± 1 cm) contact in this area. When blades are turned by hand in opposite directions against each other, there should be only light resistance to turning. Re-adjust blade scraper if necessary to center it between the blades.

NOTE: Replace blades if proper blade-to-blade contact cannot be maintained after relocating machine bushings or if blade diameter wears below $14\frac{1}{2}"$ (~37 cm).

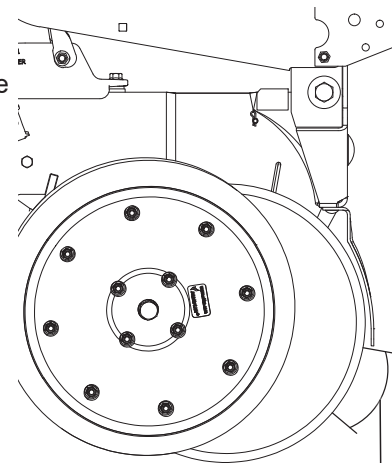

Approximately $1" \pm \frac{1}{2}"$
(3 ± .5 cm) of
blade-to-blade contact.

REPLACE DISC BLADE/BEARING ASSEMBLY

NOTE: Only bearing may need to be replaced if there is excessive endplay or if bearing sounds or feels rough when disc blade is rotated.

1. Remove gauge wheel, scraper, and bearing dust cap.
2. Remove cap screw, washer and disc blade/bearing assembly. Machine bushings between shank and disc blade are used to maintain approximate $1" \pm \frac{1}{2}"$ ($\sim 2,5 \pm 1$ cm) of blade-to-blade contact.

NOTICE

Left hand side of opener uses a left hand threaded cap screw. **DO NOT OVER TIGHTEN.** Damage to shank threads require replacement of row unit shank assembly.

3. Install machine bushing(s), new disc blade bearing assembly, washer and cap screw. Torque $\frac{5}{8}"$ -11 Grade 5 cap screw to 110 ft-lb (~ 149 Nm).

NOTE: Replace disc blades only with disc blades of equal thickness.

4. Install bearing dust cap, scraper, and gauge wheel.

REPLACE BEARING ONLY

1. Remove gauge wheel, scraper, bearing cap, cap screw, washer and disc blade/bearing assembly.
2. Remove $\frac{1}{4}"$ rivets from bearing housing to expose bearing.
3. Installing new bearing. install three evenly spaced $\frac{1}{4}"$ cap screws into three of six holes in bearing housing to hold bearing and bearing housing in place. Install rivets in other three holes. Remove $\frac{1}{4}"$ cap screws and install rivets in those three holes.
4. Reinstall disc blade/bearing assembly, washer and cap screw. Torque $\frac{5}{8}"$ -11 cap screw to 110 ft-lb (~ 149 Nm).
5. Install bearing dust cap, scraper, and gauge wheel.

SEED TUBE GUARD/INNER SCRAPER

Seed tube guard protects seed tube and acts as inner scraper for seed opener disc blades.

Remove seed tube and check for wear. Excessive wear on seed tube indicates a worn seed tube guard. Replace seed tube guard if it measures $\frac{5}{8}$ " (~16 mm) or less at lower end. A new seed tube guard measures approximately $\frac{7}{8}$ " (~22 mm).

NOTE: No till planting or planting in hard ground conditions, especially when planter is not equipped with no till coulters, and/or excessive blade-to-blade contact increases seed tube guard wear and requires more frequent inspection and/or replacement.

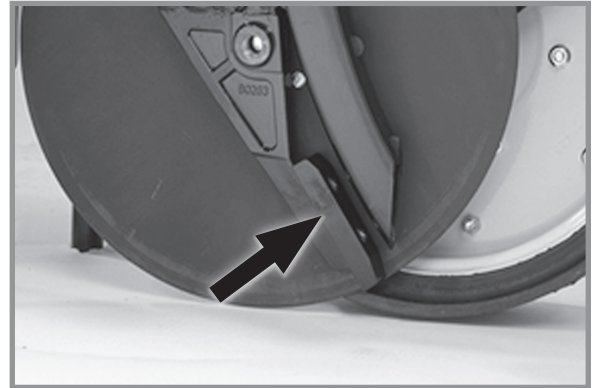

Seed tube guard/inner scraper
(Gauge wheel/seed opener disc blade removed)

NOTICE

Over tightening hex socket head cap screws may damage shank threads and require replacement of shank. An excessively worn seed tube guard may allow blades to wear into row unit shank, also requiring replacement of shank.

Remove seed tube and two hex socket head cap screws that attach seed tube guard. Hold replacement seed tube guard centered between seed opener disc blades. Install hex socket head cap screws. **DO NOT TIGHTEN.** Using a clamp or vise-grip, squeeze opener blades together in front of seed tube guard. Tighten seed tube guard retaining screws. Remove clamps. Distance between seed tube guard and opener blades should be equal on both sides. Reinstall seed tube.

ROW UNIT MOUNTED NO TILL COULTER



(One sleeve for coulters mounted residue wheels)

Check nuts and hardware periodically for proper torque.

NOTE: Torque $\frac{5}{8}$ " spindle hardware to 120 ft-lb (~162 Nm).

Be sure coulters is positioned square with row unit and aligned in front of row unit disc opener.

Coulters blade can be adjusted to one of four settings. Initially blade is set in highest position. As blade wears it can be adjusted to one of three lower settings. See "Row Unit Mounted No Till Coulters" in Row Unit Operation section of this manual.

Replace 16" diameter coulters blade when worn to 14½" (~37 cm).

COULTERS MOUNTED RESIDUE WHEELS



Wheel hubs are equipped with sealed bearings. If bearings sound or feel rough when wheel is rotated, replace them.

SPIKED CLOSING WHEEL

Inner parts of spiked closing wheel will begin to wear at approximately 70% of life. Flip/reverse wheel to utilize remaining life of wheel.

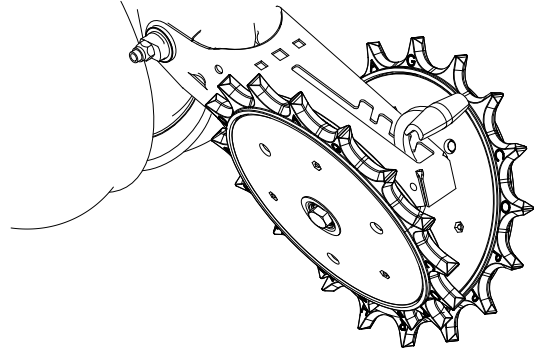

Row Unit Spiked Closing Wheel

GRANULAR CHEMICAL ATTACHMENT

Before storing planter, disengage granular chemical drive by rotating throwout knob $\frac{1}{4}$ turn counterclockwise. Remove drive chain and empty and clean all granular chemical hoppers. Clean drive chains and coat them with a rust preventive spray or submerge chains in oil. Inspect and replace worn or broken parts.

Install hoppers and chains. Check chain alignment.

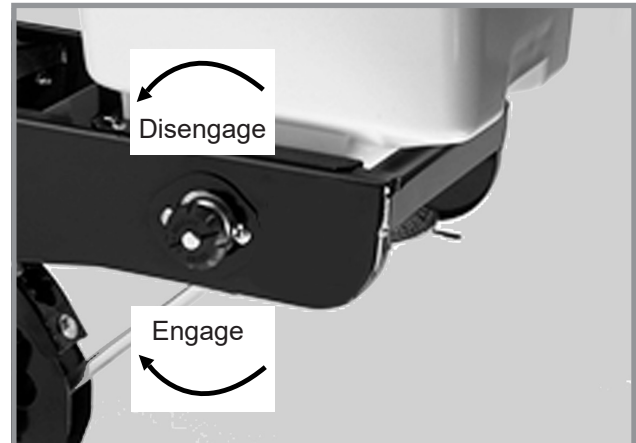

WEAR PAD ADJUSTMENT/REPLACEMENT

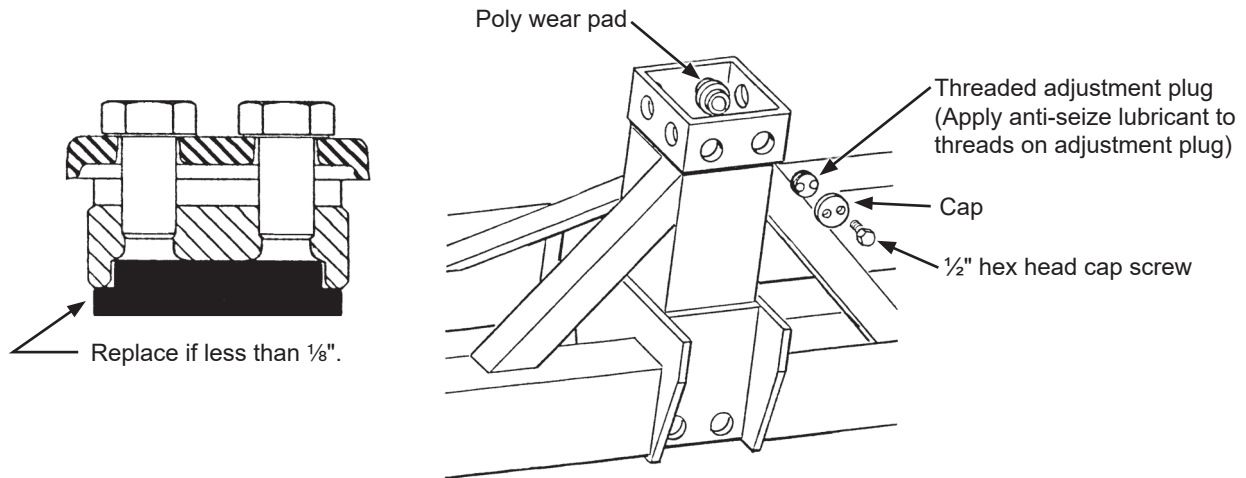

Planter center section consists of a steel tubular frame and 16 adjustable wear pad assemblies that travel up and down against a stainless steel clad center post. Each adjustable wear pad assembly consists of a poly wear pad, threaded adjustment plug, and cap. Assembly is held in place by the threaded adjustment plug and locked in place by the cap and two ½" hex head cap screws.

Check pad adjustment and wear annually on all wear pad assemblies.

1. Support frame with appropriate weight-rated safety stands at a comfortable working height with all row units off ground.
2. Level planter frame side to side and front to rear. with planter axle.
3. Remove two ½" hex head cap screws and cap. Reinstall hex head cap screws into adjustment pad and remove threaded adjustment plug and poly wear pad using hex head cap screws as a handle.
4. Replace poly wear pad if worn to less than ⅛".

NOTICE

Over tightening hex socket head cap screws may damage shank threads and require replacement of shank. An excessively worn seed tube guard may allow blades to wear into row unit shank, also requiring replacement of shank.

5. Apply anti-seize lubricant to threads of adjustment plug ONLY. Hand tighten poly wear pad and adjustment plug until poly wear pad lightly contacts stainless steel clad center post. Maximum allowable gap is no more than .060".
6. Install cap with two ½" cap screws. Torque cap screws to 25-30 ft-lb (~34 - 41 Nm).

ROW MARKER SEQUENCING/FLOW CONTROL VALVE INSPECTION

WARNING

Pressurized hydraulic fluid can penetrate body tissue and result in death, serious infection, or other injuries. Fluid injected under skin must be **IMMEDIATELY** removed by a surgeon familiar with this type of injury. Make sure connections are tight and hoses and fittings are not damaged before applying system pressure. Leaks can be invisible. Keep away from suspected leaks. Relieve pressure before searching for leaks or performing any system maintenance.



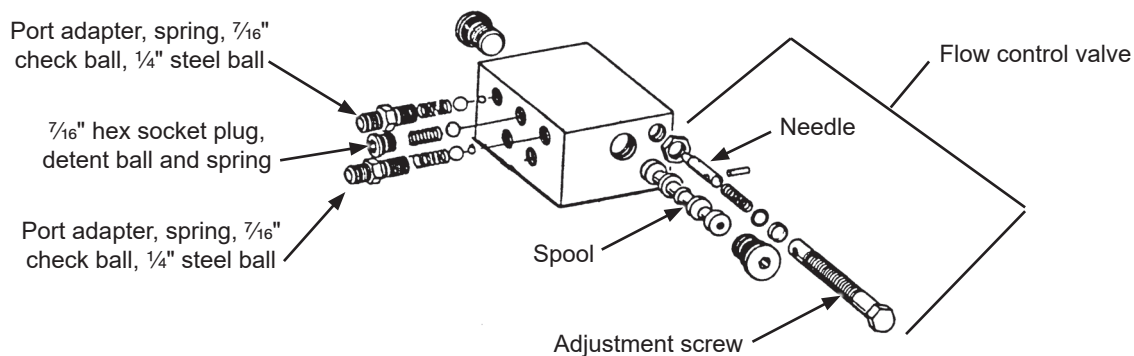

The valve block assembly consists of the row marker sequencing and flow control valves in one assembly. Sequencing valve portion consists of a chambered body containing a spool and series of check valves to direct hydraulic oil flow.

1. Remove valve block assembly from planter.
2. Remove detent assembly and port adapter assemblies from rear of valve block.

NOTICE

Damage to spool may occur if detent assembly and port adapter assemblies are not removed prior to removal of spool.

3. Remove plug from both sides of valve block and remove spool.
4. Inspect all parts for pitting, contamination, or foreign material. Check seating surfaces inside valve. Replace defective parts.
5. Lubricate spool with a light oil and reinstall. Check spool moves freely in valve body.

NOTE: Make sure correct check ball(s) and spring are installed in each valve bore upon reassembly.

A flow control valve is located on each side of block assembly. Adjust flow control valves for raise and lower speed as part of assembly procedure or upon initial operation. If valve fails to function properly or requires frequent adjustment, remove needle valve for inspection. Check for foreign material and contamination. Make sure needle moves freely in adjustment screw. Replace defective components.

PTO PUMP DRIVE AND OIL COOLER OPTION

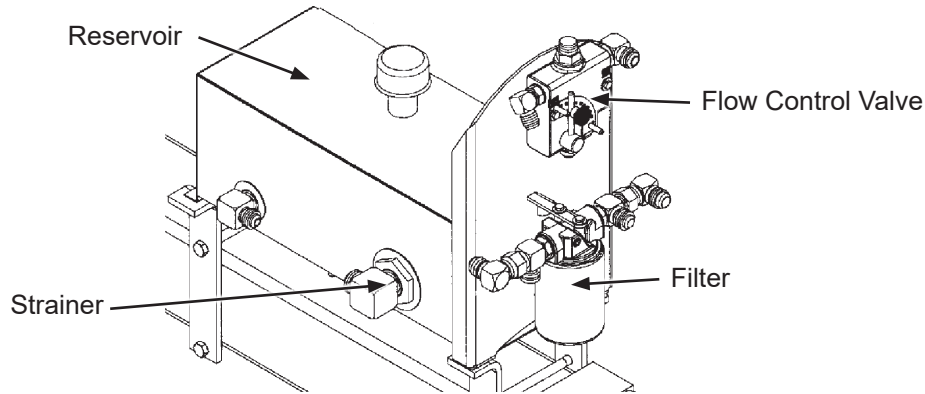

Drain reservoir, clean strainer and change filter annually.

1. Disconnect suction line (hose between reservoir and pump) from reservoir and drain. To fully drain tank, raise planter to field raised position.
2. Replace filter with good quality 10 micron filter.
3. Fill system with multigrade wide temperature range transmission hydraulic fluid. Reservoir capacity is approximately 10 gallons (38 l). See [“Oil Specification” on page 2-10](#) for more information.
4. Start system and run with tractor at idle and fan turned off for 1-2 minutes. Switch fan to full speed and run with tractor at idle for 1-2 minutes.
5. Check reservoir fluid level and fill as required. Hydraulic fluid level should be within 1"-2" (~3 cm - 5 cm) from top of reservoir after pump has run and hydraulic hoses have been primed to allow fluid to expand when heated.
6. Bring tractor to PTO speed and adjust flow control to the desired vacuum level using the flow control valve lever.

CHECK VALVE INSPECTION (In valve block below vacuum fan motor assembly)

Check valve return prevents reverse operation of vacuum fan motor. Remove and check for foreign material or if O-ring is leaking internally. Clean or replace if defective.



ROW MARKER BEARING LUBRICATION OR REPLACEMENT

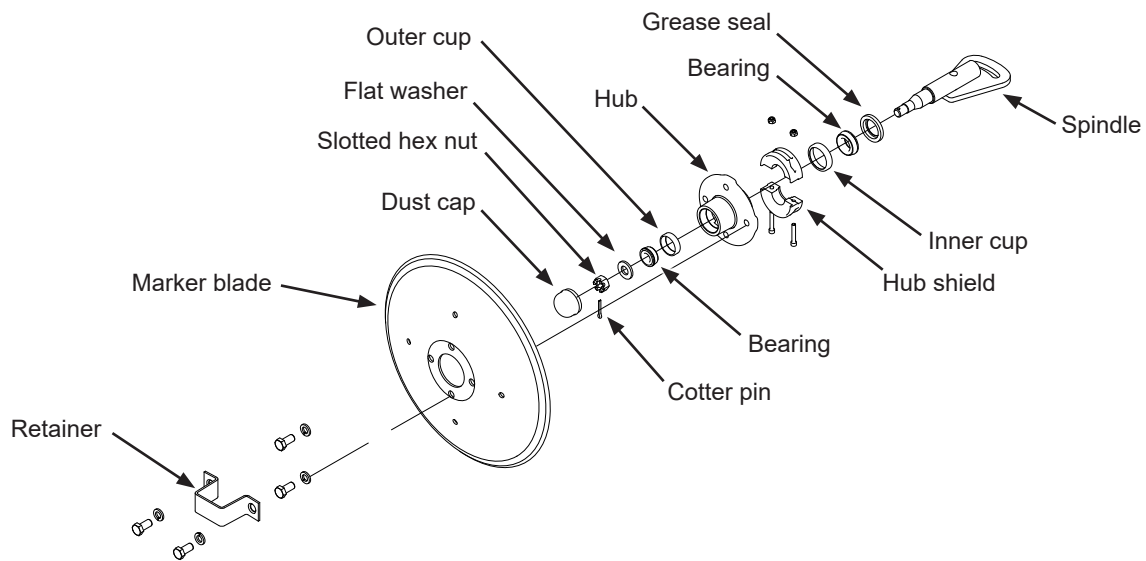

1. Remove retainer and marker blade.
2. Remove dust cap from hub.
2. Remove hub shield. Note direction of installation.
3. Remove cotter pin, slotted hex nut, and washer.
4. Slide hub from spindle.
5. Remove bearings and cups and discard if bearings are being replaced. Clean hub and dry. Remove bearings only and not cups if repacking.
6. Press in new bearing cups with thickest edge facing in. (Bearing replacement procedure only.)
7. Pack bearings with heavy duty wheel bearing grease thoroughly forcing grease between roller cone and bearing cage. Fill the space between the bearing cups in the hub with grease.
8. Install rubber seal into grease seal. Place inner bearing in place and press in new rubber seal/grease seal.
9. Clean spindle and install hub.
10. Install outer bearing, washer and slotted hex nut. Tighten slotted hex nut while rotating hub until there is some drag. This ensures all bearing surfaces are in contact. Back off slotted nut to nearest locking slot and install cotter pin.
11. Fill dust caps approximately $\frac{3}{4}$ full of wheel bearing grease and install on hub.
12. Install hub shield.
13. Install marker blade and retainer on hub. Tighten hardware evenly.

WHEEL BEARING REPACK OR REPLACEMENT

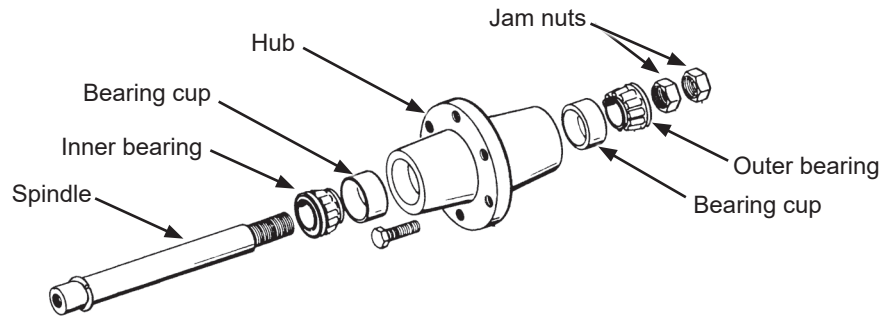

1. Raise tire clear of ground and remove wheel.
2. Remove double jam nuts and slide hub from spindle.
3. Remove bearings and cups and discard if bearings are being replaced. Clean hub and dry. Remove bearings only and not cups if repacking.
4. Press in new bearing cups with thickest edge facing in. (Bearing replacement procedure only.)
5. Pack bearings with heavy duty wheel bearing grease thoroughly forcing grease between roller cone and bearing cage. Fill space between bearing cups and hub with grease.
6. Place inner bearing in place.
7. Clean spindle and install hub.
8. Install outer bearing and jam nut. Tighten jam nut while rotating hub until there is some drag. This ensures all bearing surfaces are in contact. Back off jam nut $\frac{1}{4}$ turn or until there is only slight drag when rotating hub. Install second jam nut to lock against first.
9. Install wheel on hub. Tighten hardware evenly.

FERTILIZER CHECK VALVE CLEANING AND REPAIR

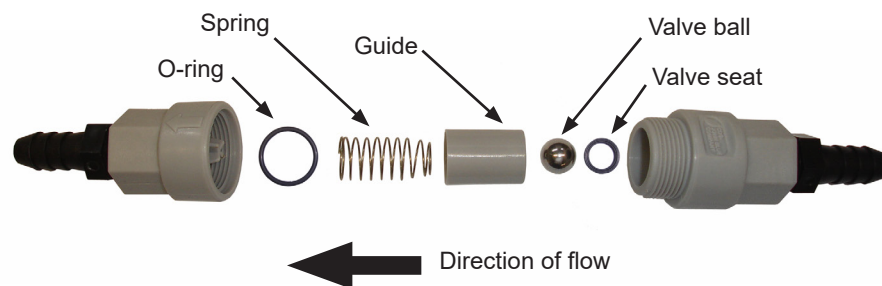

1. Unscrew valve body and separate halves. Note direction and location of parts.
2. Clean and inspect parts. Flush with clean water. Replace damaged parts.
3. Reassemble exactly as shown. O-ring and valve seat must be firmly in place inside each half of valve body.

PISTON PUMP MAINTENANCE

- Check oil daily and fill crankcase to proper level with a quality grade SAE 90 weight gear oil. With the pump sitting level, the oil should be within 1/2" of the bottom of the hole on back of crankcase. You may use a long wire or zip tie as a dipstick to check the level – some length is required due to the hole's depth.
- Lubricate all grease zerks on roller chain sprocket spacer, outboard cover plate, crankshaft end, and at stuffing box flange daily. Fill zerks until grease is visibly seen seeping from mating parts. For the stuffing box flange zerk, grease will be seen seeping from the vent on the opposite side of the flange.
- Pump oil should be changed seasonally or more often in extreme use conditions.
- Visually inspect sprocket and drive chain daily for excessive wear or corrosion. Lubricate chain regularly to reduce corrosion. Chain alignment must be straight.

PISTON PUMP STORAGE

NOTICE

Keep air out of the pump! This is the only way to prevent corrosion. Even for short periods of storage, the entrance of air into the pump causes **RAPID and SEVERE CORROSION**. Freezing temperatures can cause the fluid or water to freeze internally to the pump, which can cause severe damage to the wet-end castings.

OVERNIGHT

Suspension fertilizer must be flushed from the pump for ANY storage period. For Clear Liquids:

1. Steady or rising temperatures: leave pump and hoses filled with solution. DO NOT DRAIN nor admit air to the pumps.
2. Cooling weather: (solution likely to salt out), fill pump with water and leave filled. DO NOT admit air.
3. Freezing temperature: fill pump with RV-antifreeze and leave filled, DO NOT admit air.

ONE TO TWO WEEKS

ACCEPTABLE: Flush pump thoroughly with 5 to 10 gallons of a solution that will neutralize the liquid last pumped (refer to that manufacturer's instructions). Fill with clean water and DO NOT DRAIN. Keep pump sealed to exclude air. If freezing temperatures are remotely possible, the winter storage procedure (see below) must be used to avoid damage to the pump castings.

PREFERRED: Flush pump as detailed above. IMMEDIATELY fill all passages in pump with straight RV antifreeze which contains a rust inhibitor. Place 1-1/2" NPT PVC plugs in the suction and discharge fittings to keep pump full and exclude air.

WINTER STORAGE

1. Flush pump as detailed above.
2. With pump set on 10, draw in straight RV-antifreeze until the discharge is clean. If system utilizes a flow divider (FD), pump the RV-antifreeze through the FD manifold until it is seen in the discharge lines. Fill pump and plug suction and discharge fittings of pump to retain RV-antifreeze.

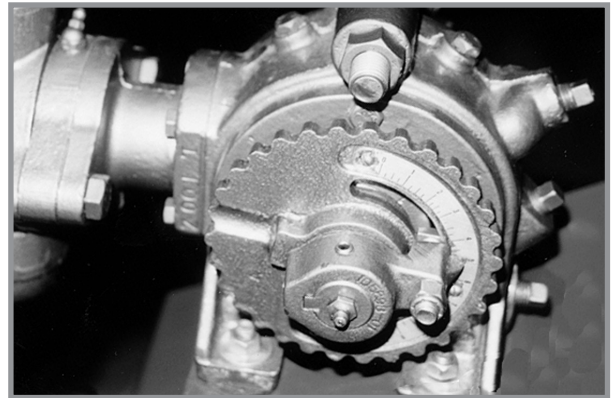
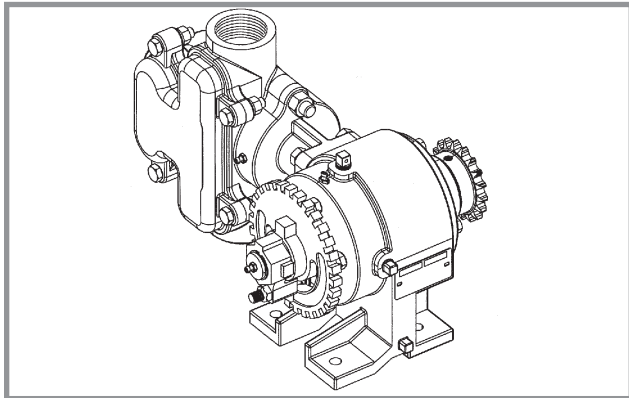

Liquid fertilizer piston pump

PREPARING PLANTER FOR STORAGE

- Store planter in a dry sheltered area if possible.
- Remove all trash that may be wrapped on sprockets or shafts and remove dirt that can draw and hold moisture.
- Clean all drive chains and coat with a rust preventative spray, or remove chains and submerge in oil.
- Lubricate planter and row units at all lubrication points.
- Inspect planter for parts that are in need of replacement and order during “off” season.
- Make sure seed and granular chemical hoppers are empty and clean.
- Clean seed meters and store in a dry, rodent-free area.
- Grease or paint disc openers/blades and row marker disc blades to prevent rust.
- Flush liquid fertilizer tanks, hoses and metering pump with clean water.
- Empty and clean dry fertilizer hoppers. Disassemble and clean metering augers. Reassemble and coat all metal parts with rust preventative.

HYDRAULIC HOSE LIFE

 **WARNING**

Pressurized hydraulic fluid can penetrate body tissue and result in death, serious infection, or other injuries. Fluid injected under skin must be **IMMEDIATELY** removed by a surgeon familiar with this type of injury. Make sure connections are tight and hoses and fittings are not damaged before applying system pressure. Leaks can be invisible. Keep away from suspected leaks. Relieve pressure before searching for leaks or performing any system maintenance.



Proper storage of hydraulic hoses can significantly increase the life of the hoses, for a period of three to five years. After this period, service life of hoses may decrease, depending on variables such as variances in rubber materials and storage environment. Refer to the guidelines below for best practices when storing.

- Store in a clean, cool and dry area
- Avoid direct sunlight or moisture
- Do not store near high power electrical equipment
- Avoid contact with corrosive chemicals
- Avoid ultraviolet light
- Avoid areas with obvious signs of insects or rodents

Unusually long periods of storage or poor storage environment may lead to performance issues or premature failure. Always inspect all hoses prior to use for extensive wear, cuts, or holes. If such flaws are identified, replace immediately to avoid potential failure, property damage or bodily injury.

VACUUM PLANTER HYDRAULIC SYSTEM

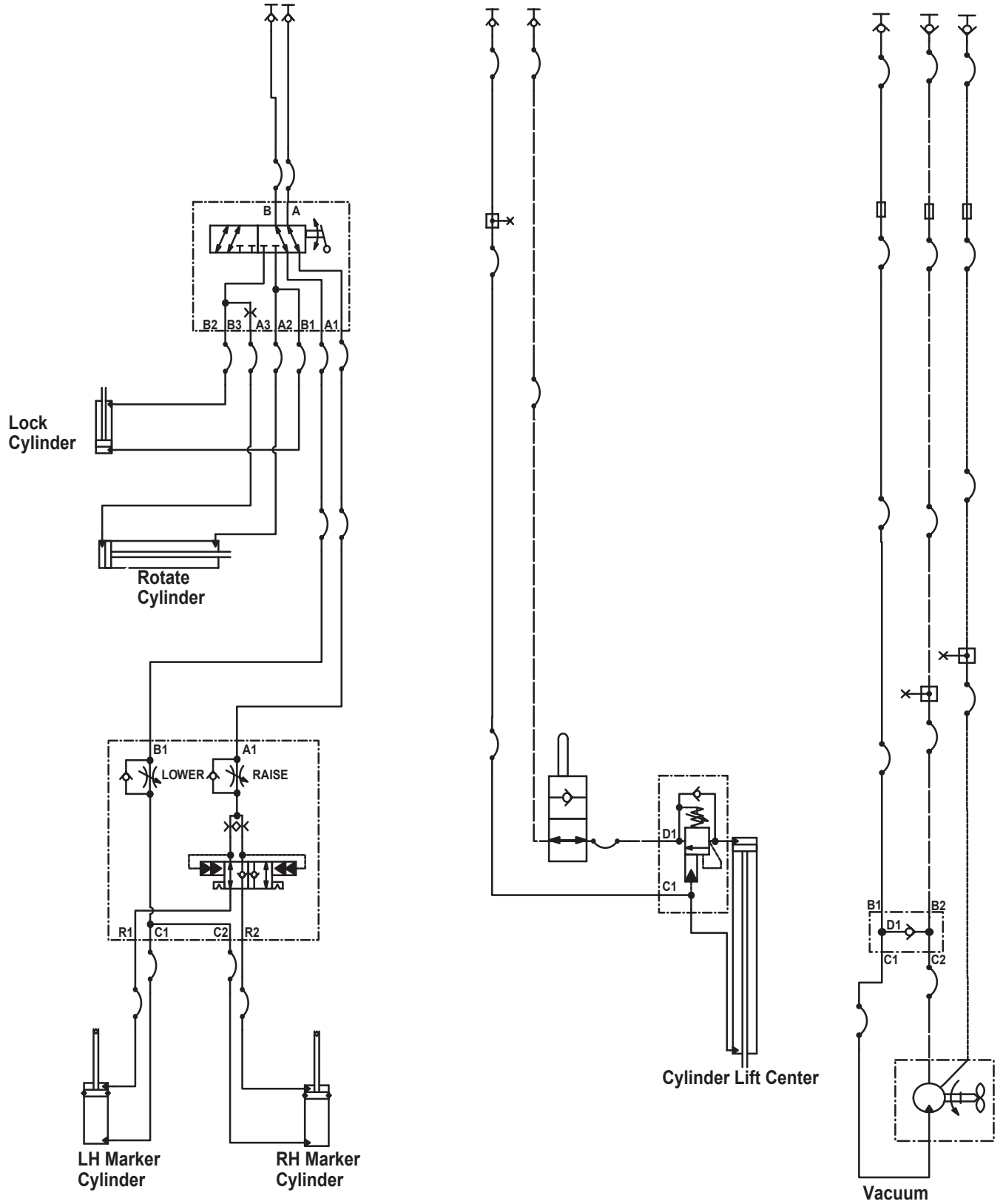

VACUUM BULK FILL PLANTER HYDRAULIC SYSTEM

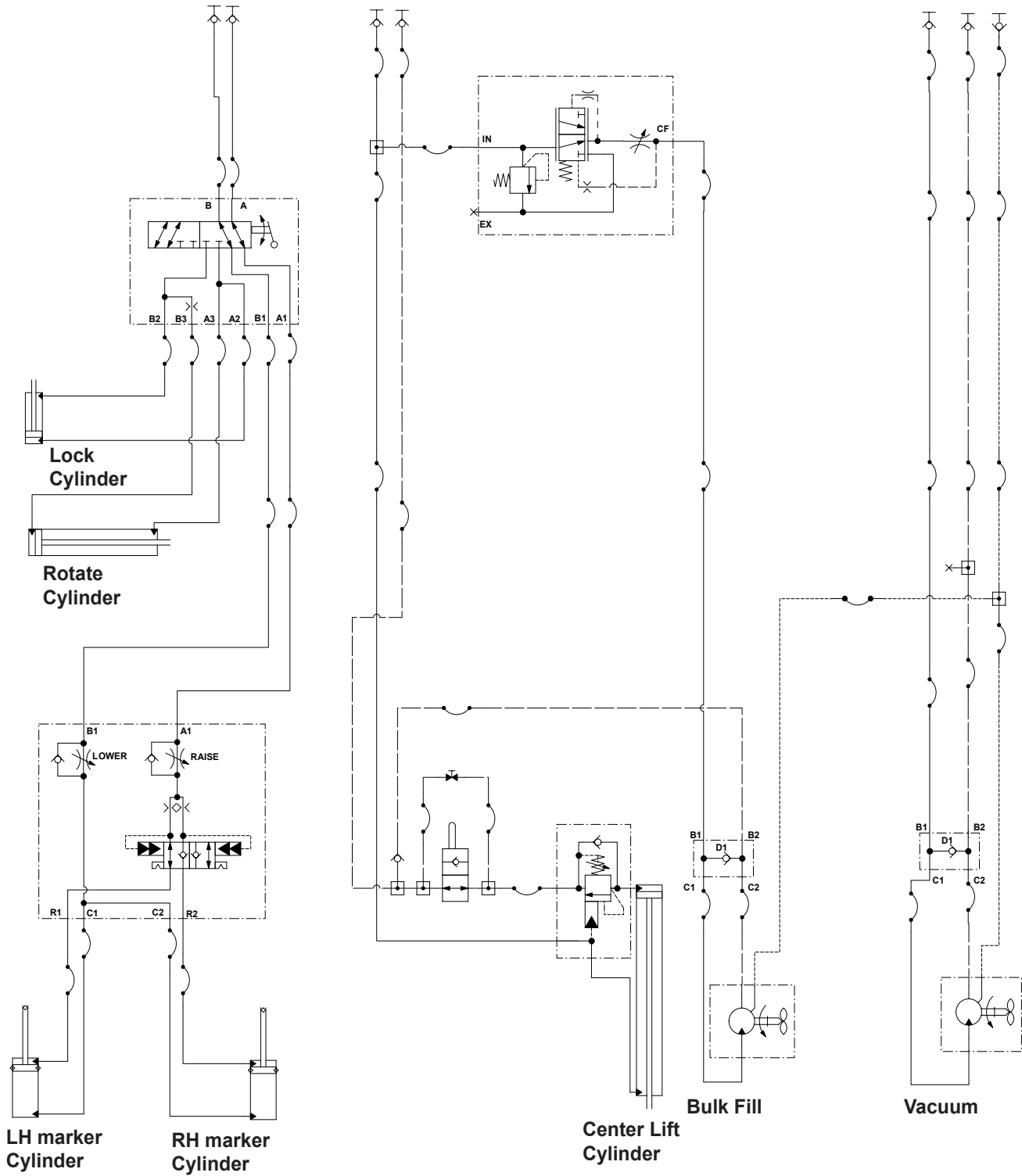

VACUUM BULK FILL PLANTER WITH PTO OPTION HYDRAULIC SYSTEM

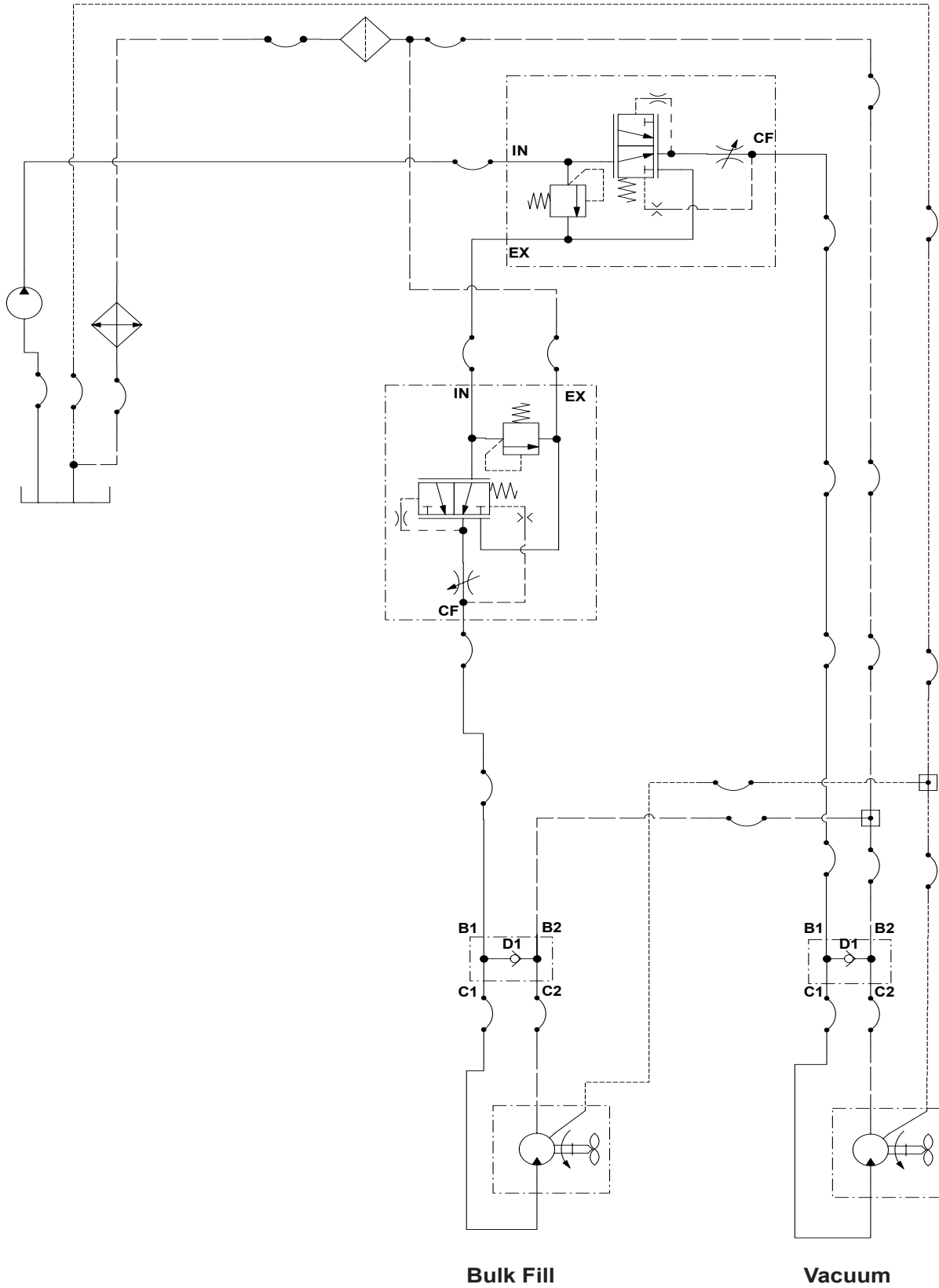

VACUUM BLUE DRIVE BULK FILL PLANTER WITHOUT PTO OPTION HYDRAULIC SYSTEM

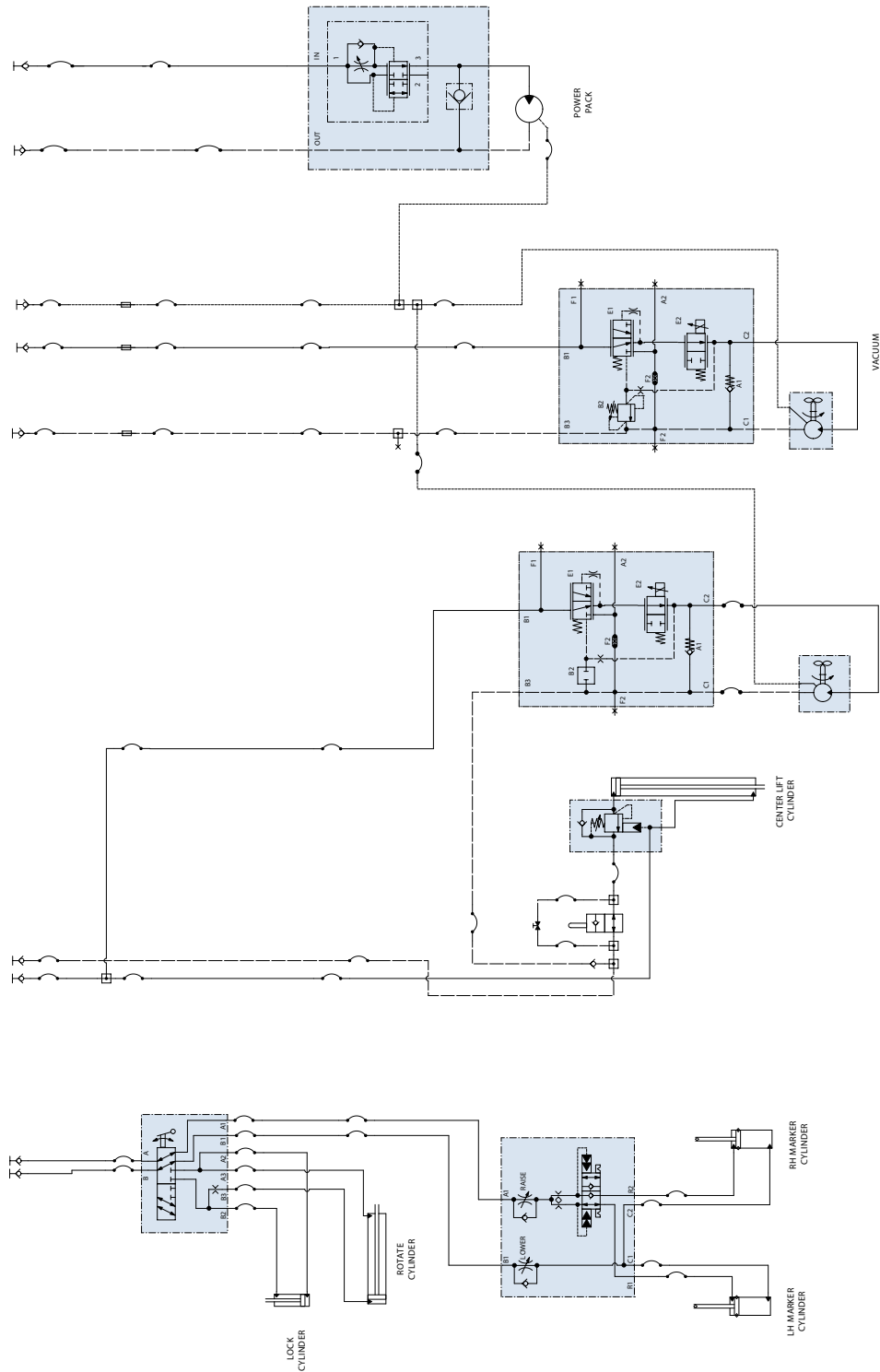

VACUUM BLUE DRIVE BLUE VANTAGE CONVENTIONAL PLANTER WITH PTO OPTION
HYDRAULIC SYSTEM

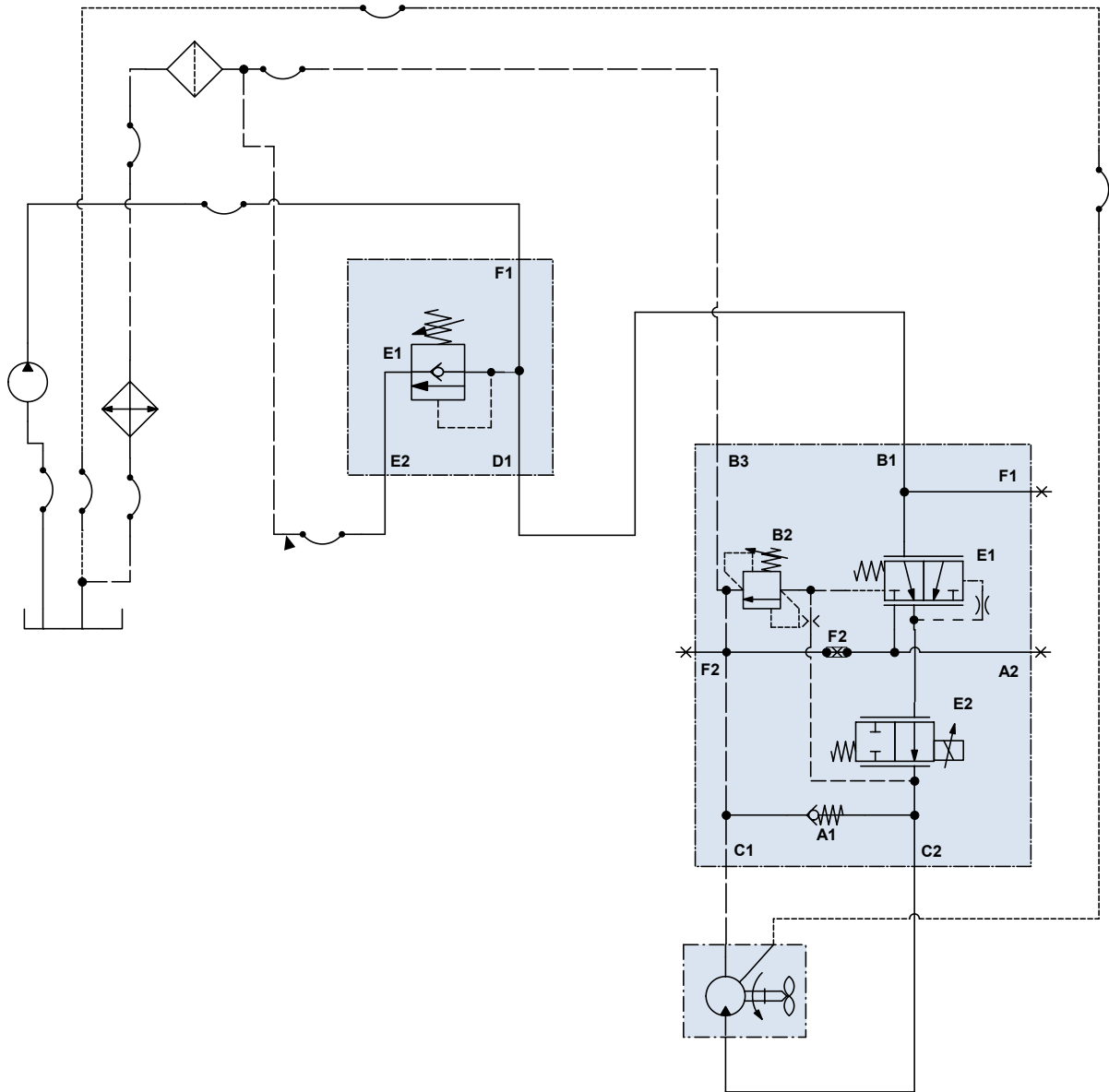

VACUUM BLUE DRIVE BLUE VANTAGE BULK FILL PLANTER WITH PTO OPTION HYDRAULIC SYSTEM

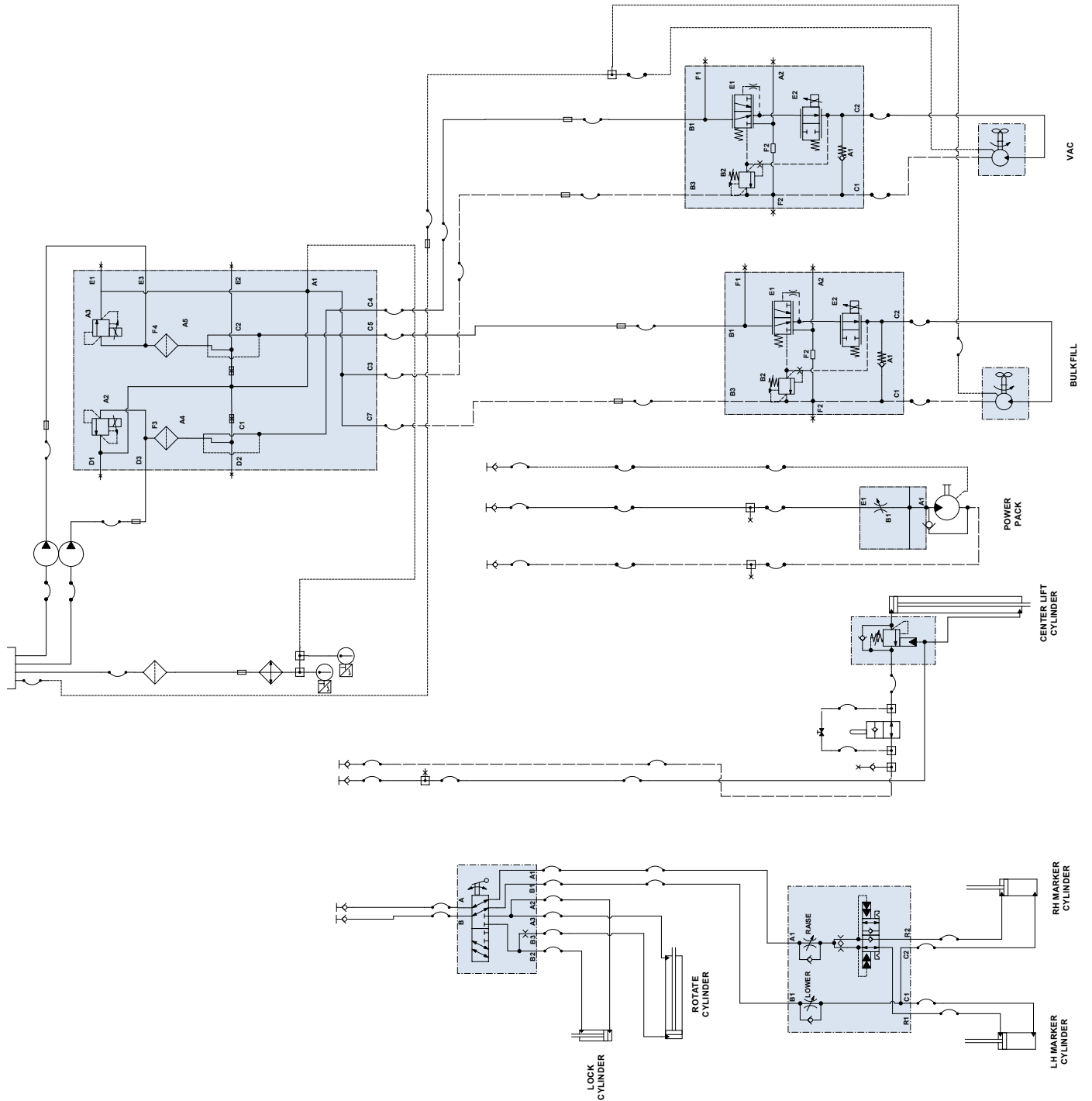

This page left blank intentionally.

HYDRAULIC DIAGRAM - VACUUM FAN MOTOR SYSTEM

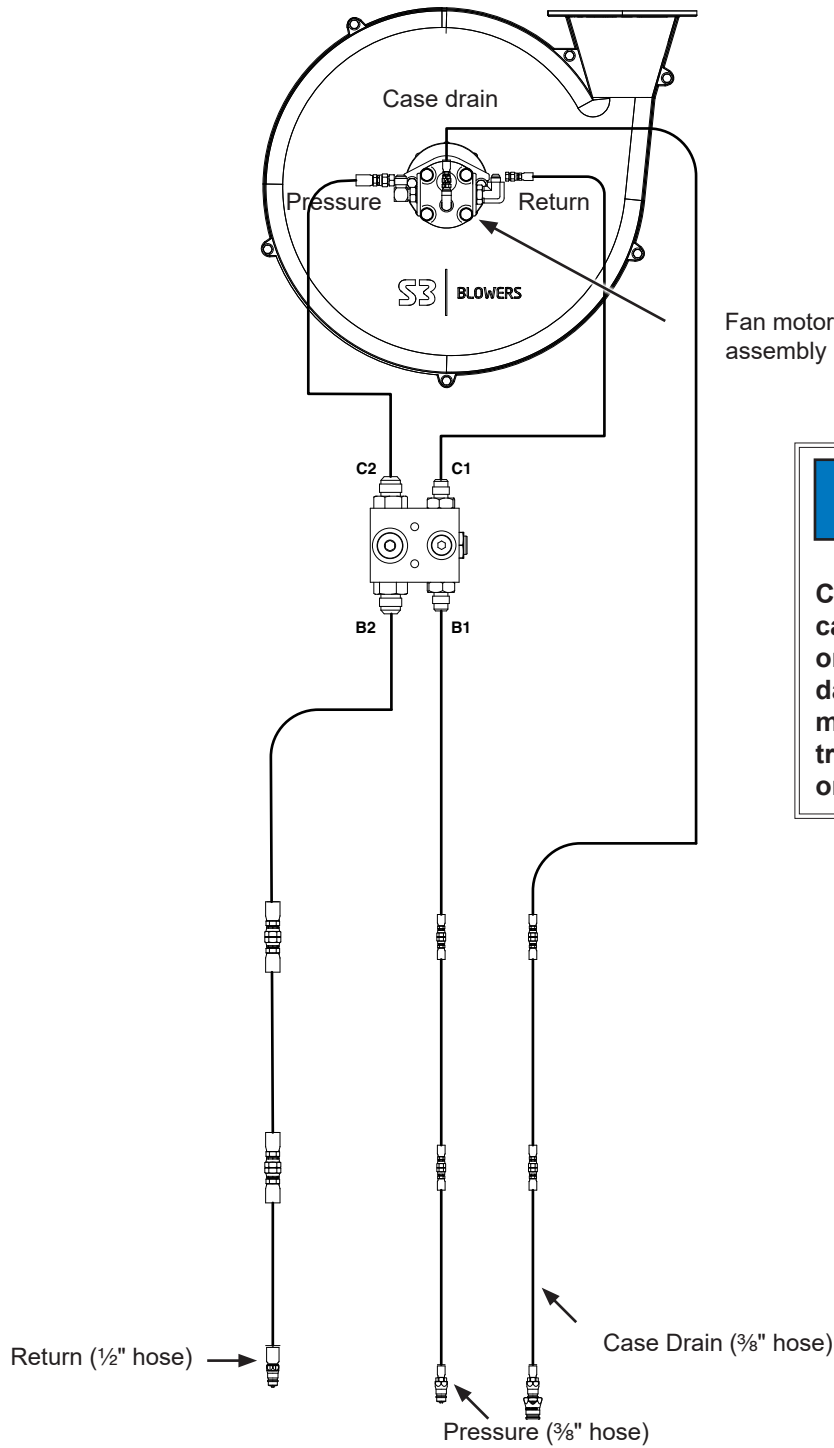

Fan motor assembly

NOTICE

Connect hydraulic motor case drain to a case drain return line with zero pressure on tractor or hydraulic motor will be damaged. DO NOT connect hydraulic motor case drain to SCV outlet. Contact tractor manufacturer for specific details on "zero pressure return".

BATTERY CARE

NOTICE	Read and follow all manufacturer labels and instructions.
---------------	--

Battery Specifications	
Chemistry:	Wet lead acid (low maintenance)
Voltage:	12.00 V
Capacity:	>7.00 Ah
Weight:	15.3 lbs (6.9 kg)
Length:	194 mm
Width:	126 mm
Height:	183 mm
Termination:	Top post L Terminal

BEFORE PLANTING SEASON

- Check and clean all connections.
- Fully charge batteries before installing into the planter.
- Batteries more than two years old should be load checked.
- Reinstall batteries or connect the negative ground cables.

PREPARATION FOR STORAGE

Planter batteries that are stored for more than one month should be cared for as follows:

- Remove the batteries or disconnect the negative ground cable.
- Fully charge batteries before storing.
- Store in a cool and dry location.
- Keep from freezing.

NOTICE	When replacing batteries, replace both at the same time. NEVER replace one battery at a time. Batteries in Power Pack must be identical to one another.
---------------	--

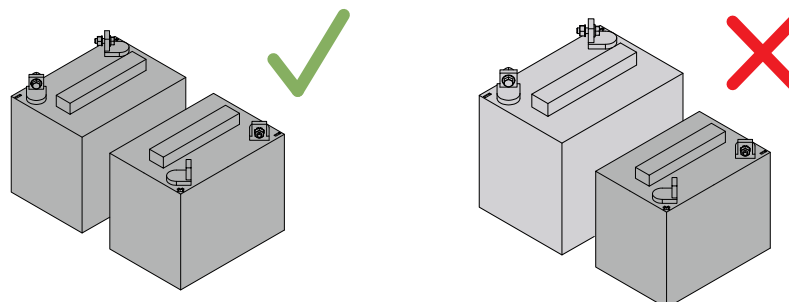

ELECTRICAL WIRING FOR LIGHTS PACKAGE

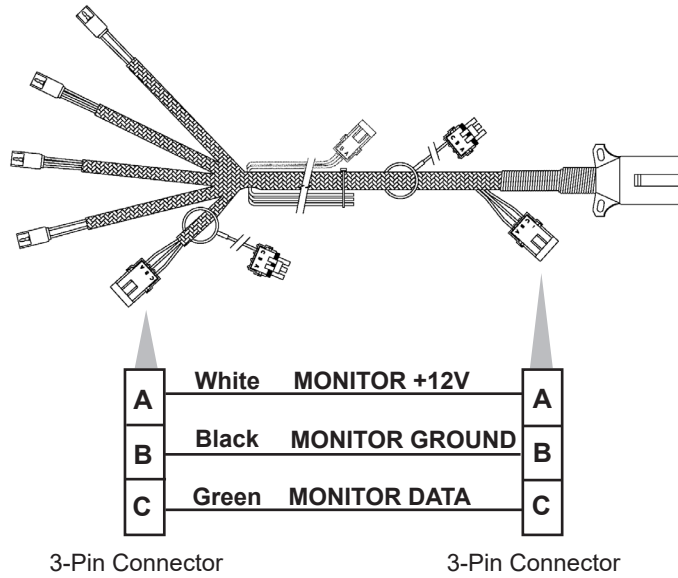

Light package meets ISO 1724 Standards. For correct wiring harness to be wired into lights on your tractor, check with tractor manufacturer.

POWER PACK WIRING DIAGRAM (BLUE DRIVE)

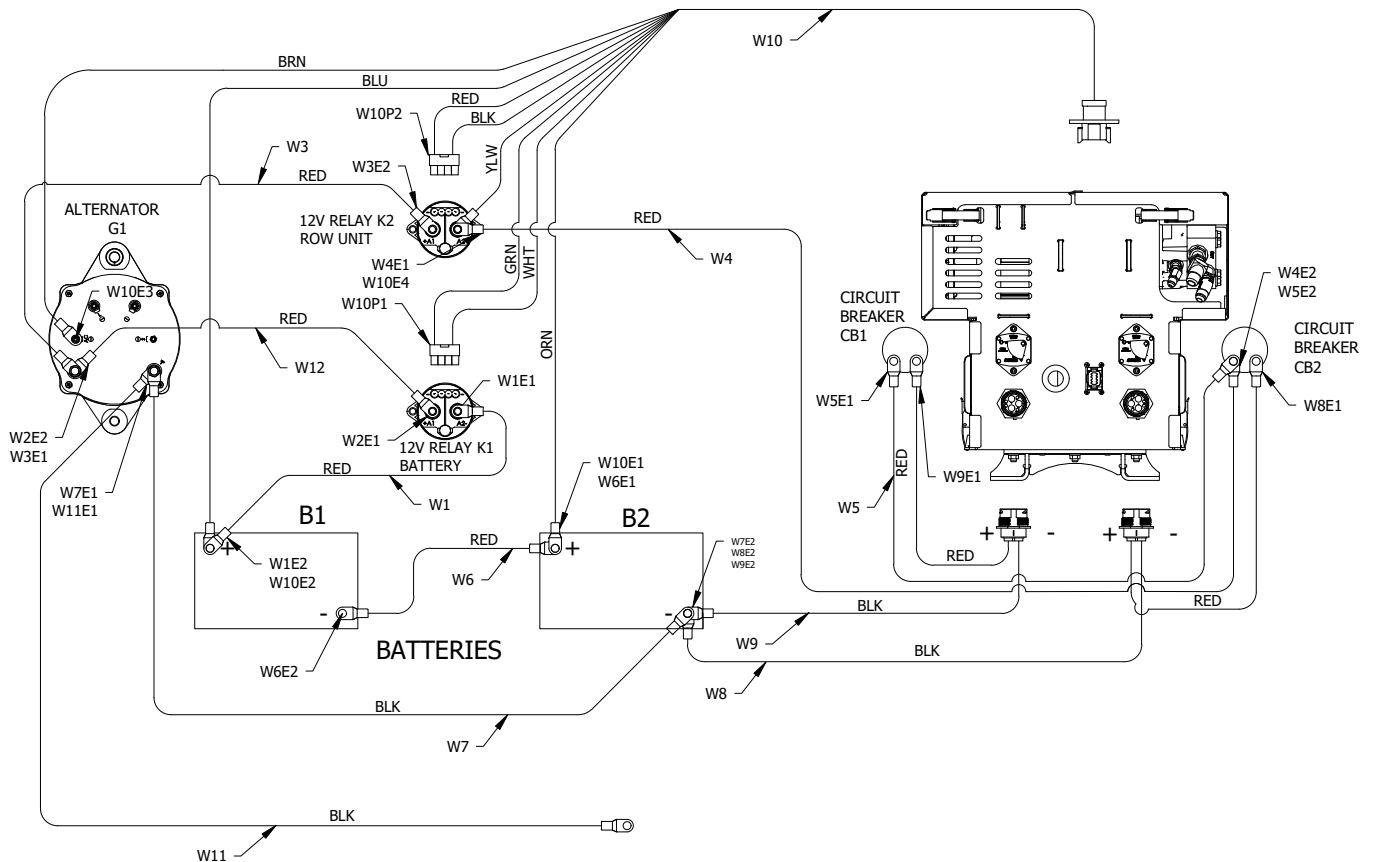

Component Hookup Chart, P/N 10112901

Reference Designator	From	Used with Item	To	Used with Item	Color	Function
W1	B1+	E2	K1A2-	E1	Red	Power
W12	K1A1+	E1	GB1+	E2	Red	Power
W3	GB1+	E1	K2A1+	E2	Red	Power
W4	K2A2-	E1	CB2, Line	E2	Red	Power
W5	CB1, Line	E1	CB2, Line	E2	Red	Power
W6	B2+	E1	B1-	E2	Red	Power
W7	B2-	E2	GB2-	E1	Black	Ground
W8	Pan	J1	CB2, Load	E1	Red	Power
			B2-	E2	Black	Ground
W9	Pan	J1	CB1, Load	E1	Red	Power
			B2-	E2	Black	Ground
W10	Pan	J1	K2	P2	Red/Black	RU Power Relay (Power & Ground)
			AC	E3	Brown	Alternator Sensor Frequency
			K2A2-	E4	Yellow	RU Power Feedback
			K1	P1	Green/White	Battery Pack Relay (Power & Ground)
			B1+	E2	Blue	Battery #1 Voltage Monitor
			B2+	E1	Orange	Battery #2 Voltage Monitor
W11	GB2-	E1	NC	E2	Black	Planter Ground

CABLES AND HARNESSSES

This section includes information on planter cable and harness connections, make up and wiring for troubleshooting, maintenance and repair purposes.

 DANGER	<p>Before attempting to repair electrical wiring, make sure the harness or cable in question is disconnected from the battery or any other power source. Failing to do so might lead to serious injury.</p>
---	--

Ethernet Cables

Color	From	To
White/Orange	P1-1	P2-1
White/Green	P1-2	P2-2
Orange	P1-3	P2-3
Green	P1-4	P2-4

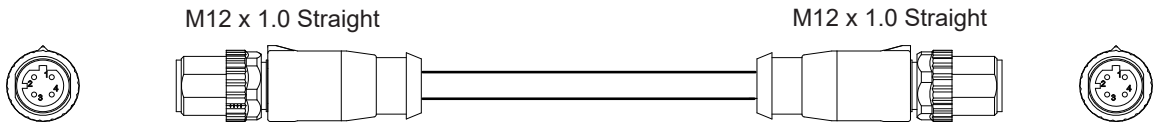

Ethernet Cable	
Part Number	Description
A22554-	Ethernet Ca CAT 5E (M12 STR-M12 STR)

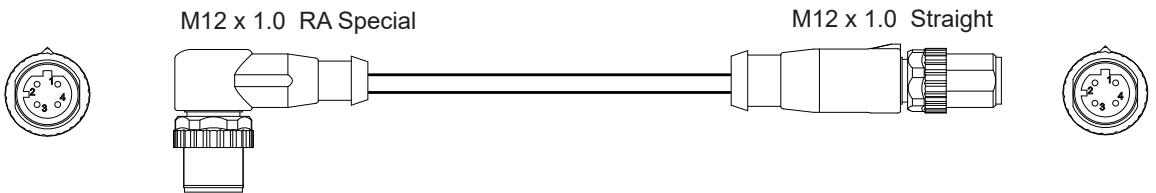

Ethernet Cable	
Part Number	Description
A22555-	Ethernet Ca CAT 5E (M12 RA-M12 STR)

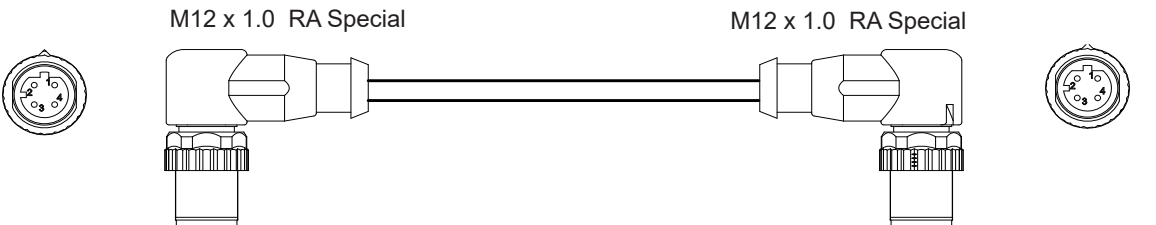

Ethernet Cable	
Part Number	Description
A22556-	Ethernet Ca CAT 5E (M12 RA-M12 RA)

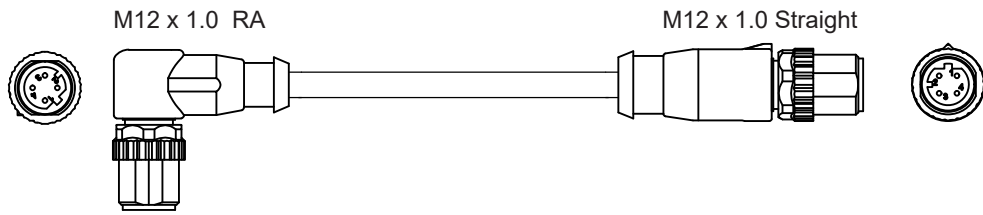

Ethernet Cable	
Part Number	Description
A24488-	Ethernet Ca CAT 5 (M12 RA-M12 STR)

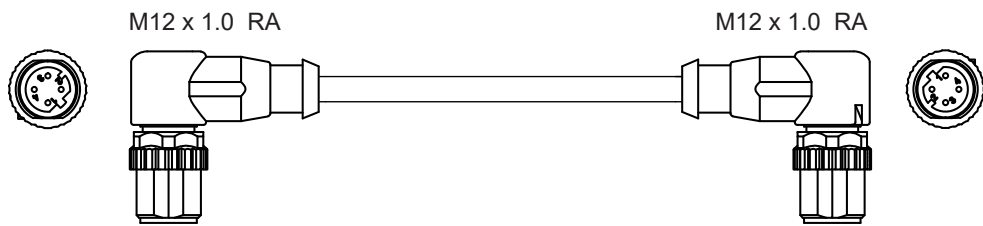

Ethernet Cable	
Part Number	Description
A24487-	Ethernet Ca CAT 5 (M12 RA-M12 RA)

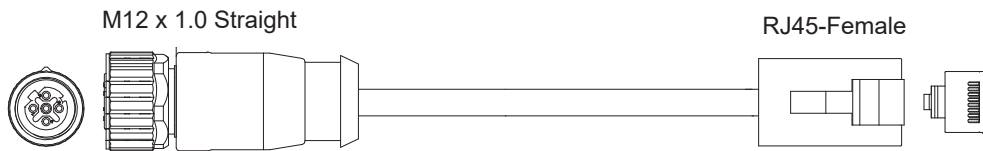

Ethernet Cable	
Part Number	Description
A25399-	Ethernet Ca CAT 5 (RJ45-Female-M12 STR)

Tractor Power Harness Extension

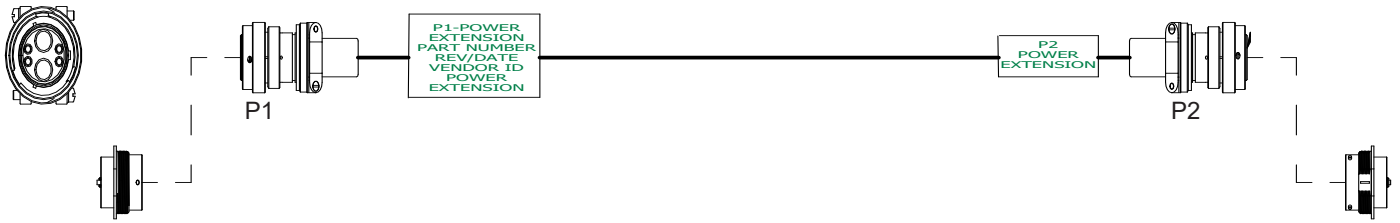

P/N A25032				
Signal	Wire Gauge	Color	From	To
12V PWR	6	Red	P1-3	P2-3
GND	6	Black	P1-4	P2-4

Harness Row Unit Power Extension

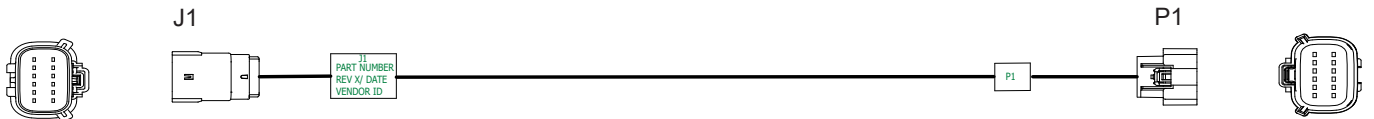

P/N A25029				
Signal	Wire Gauge	Color	FROM	TO
Power	16	Red	J1-1	P1-1
Ground	16	Black	J1-2	P1-2
Power	16	Red	J1-3	P1-3
Ground	16	Black	J1-4	P1-4
Strapping	20	Yellow	J1-5	P1-5
Strapping	20	Orange	J1-6	P1-6
Strapping	20	White	J1-7	P1-7
Strapping	20	Green	J1-8	P1-8
Strapping	20	Blue	J1-9	P1-9
Strapping	20	Violet	J1-10	P1-10
Strapping	20	Blue/Red	J1-11	P1-11
Strapping	20	Brown	J1-12	P1-12

Worklights Relay Harness

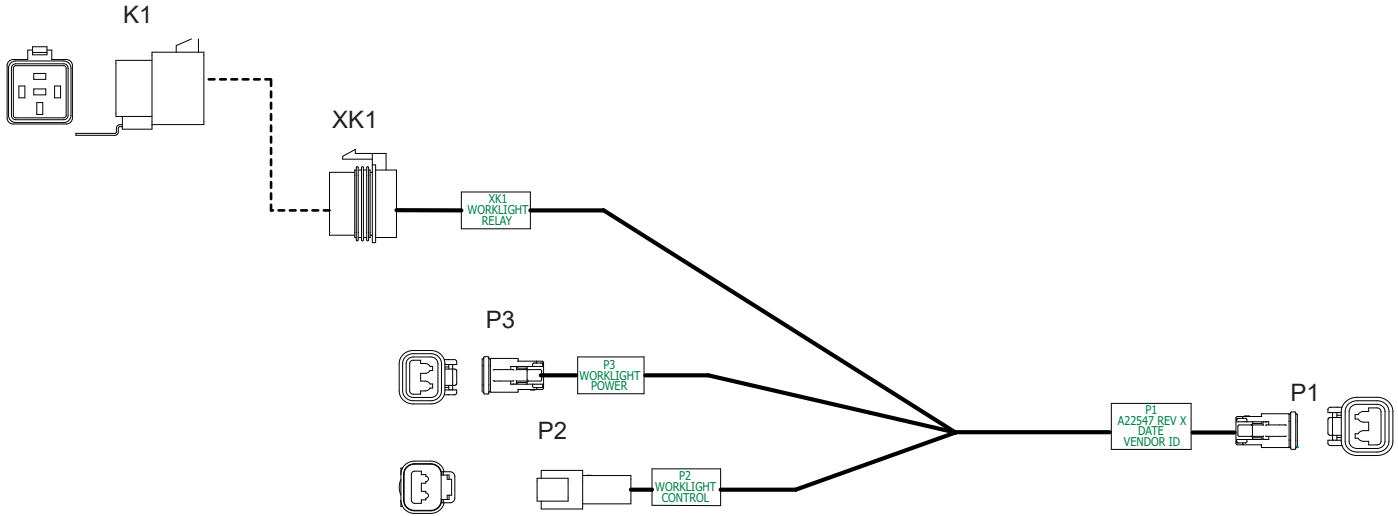

P/N A22547				
Signal	Wire Gauge	Color	From	To
Worklight Power -	16	Blue	P3-1	P1-1
Worklight Power +	16	Red	P3-2	XK1-30
Relay Ground	16	Black	P2-1	XK1-85
Relay 12V	16	Blue	P2-2	XK1-86
Worklight Power +	16	Red	XK1-87	P1-2

Harness IPP

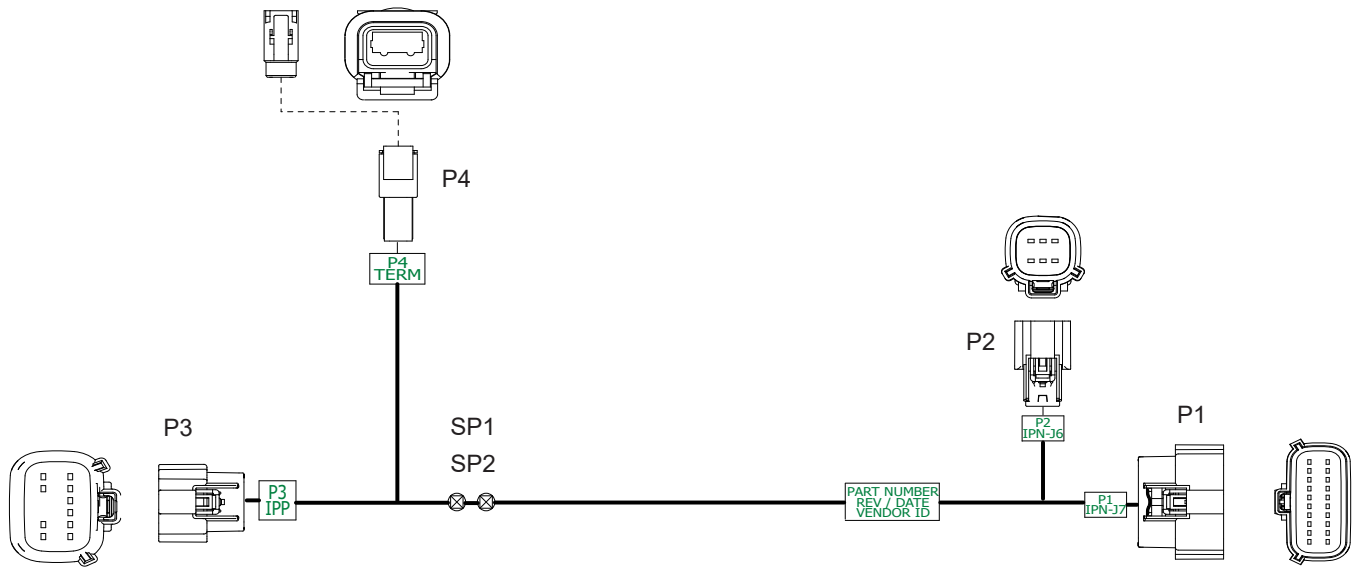

P/N A25214				
Signal	Wire Gauge	Color	From	To
RS232 RX	18(TP)	ORN	P1-1	P3-1
RS232 TX	18(TP)	BRN	P1-2	P3-2
CAN HI	18(TP)	YEL	P2-1	SP1
CAN LO	18(TP)	GRN	P2-2	SP2
Power	16	RED	P2-3	P3-12
Ground	16	BLK	P2-4	P3-6
IPP Software Update	18	BLU	P2-5	P3-11
CAN HI	18(TP)	YEL	SP1	P3-5
CAN LO	18(TP)	GRN	SP2	P3-4
CAN HI	18(TP)	YEL	SP1	P4-1
CAN LO	18(TP)	GRN	SP2	P4-2

Tractor Console Harness

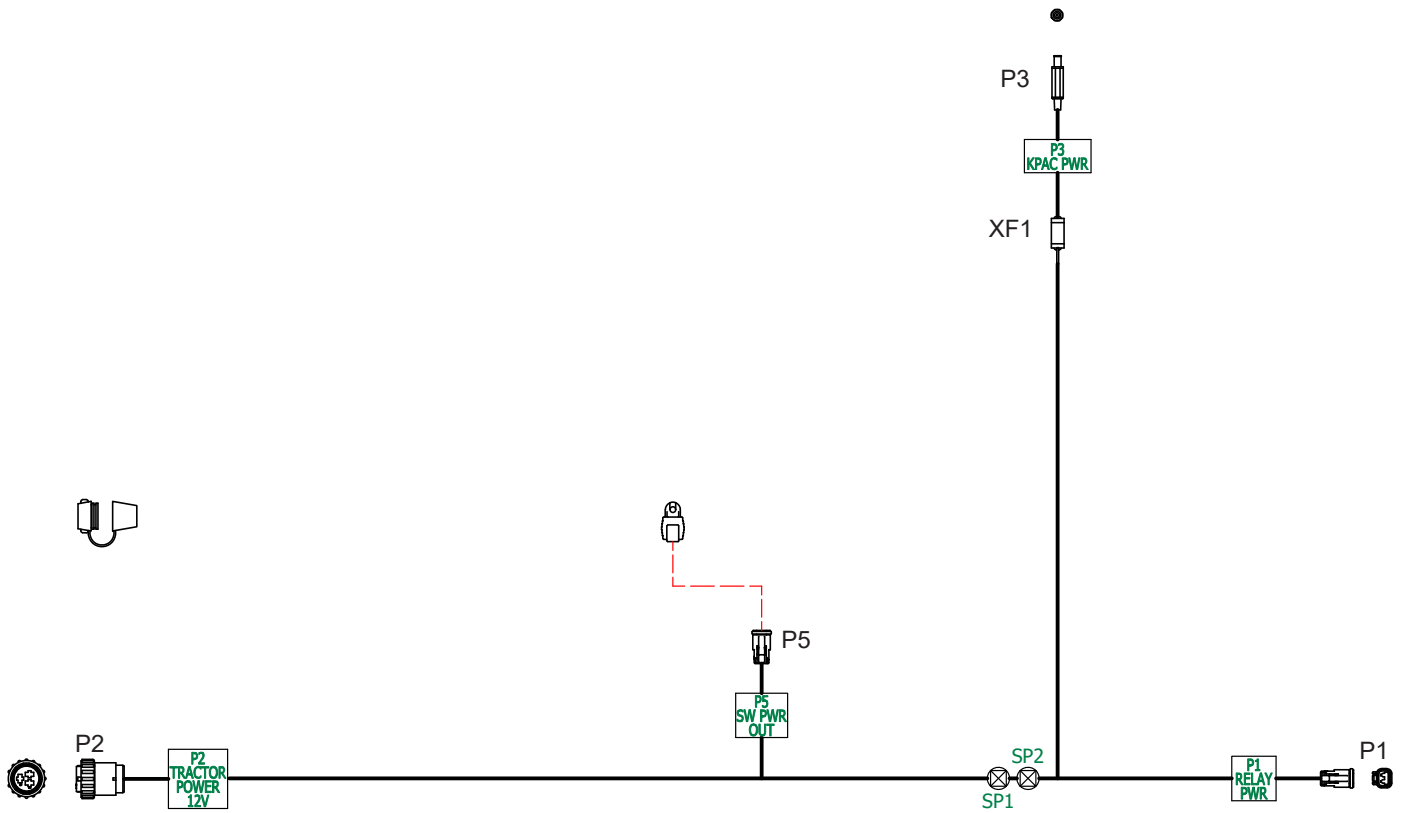

Wire Hookup Chart, P/N A25031

Reference Designator	From	To	Gauge	Color	Function
W1	P2-1	SP1	16	Red	12V Switched (Power)
W2	SP1	P1-1	18	Blue	Relay (Power)
W3	SP1	XF1-1	18	Red	12V Switched (Power)
W5	SP1	P5-1	18	Orange	12V Switched (Power)
W6	XF1-2	P3-1	18	Red	12V Switched (Power)
W8	P2-3	SP2	16	Black	12V Switched (Power)
W9	SP2	P1-2	18	Black	12V Switched (Power)
W10	SP2	P3-2	18	Black	12V Switched (Power)
W12	SP2	P5-2	18	Black	12V Switched (Power)

Tractor Power Harness

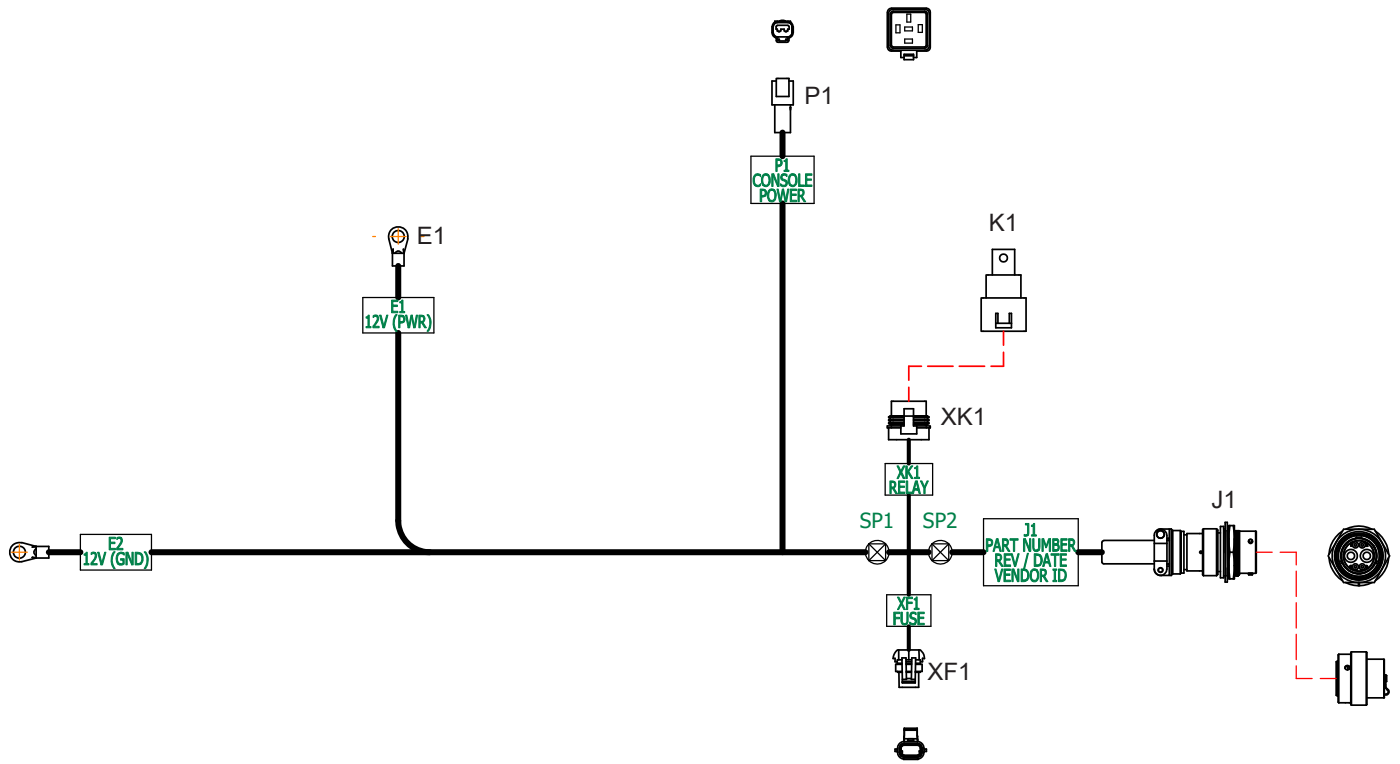

Wire Hookup Chart, P/N A25030

Reference Designator	From	To	Gauge	Color	Function
W1	E1	SP1	6	Red	12V (Power)
W2	SP1	XF1-A	12	Red	Relay (Power)
W3	XF1-B	XK1-30	12	Red	12V (Power)
W4	XK1-87	SP2	12	Red	12V (Power)
W5	SP2	J1-3	6	Red	12V (Power)
W6	E2	J1-4	6	Black	12V (Ground)
W7	P1-1	XK1-86	18	Blue	Relay (Power)
W8	P1-2	XK1-85	18	Black	12V Switched (Ground)

Row Unit Seed Meter Harness

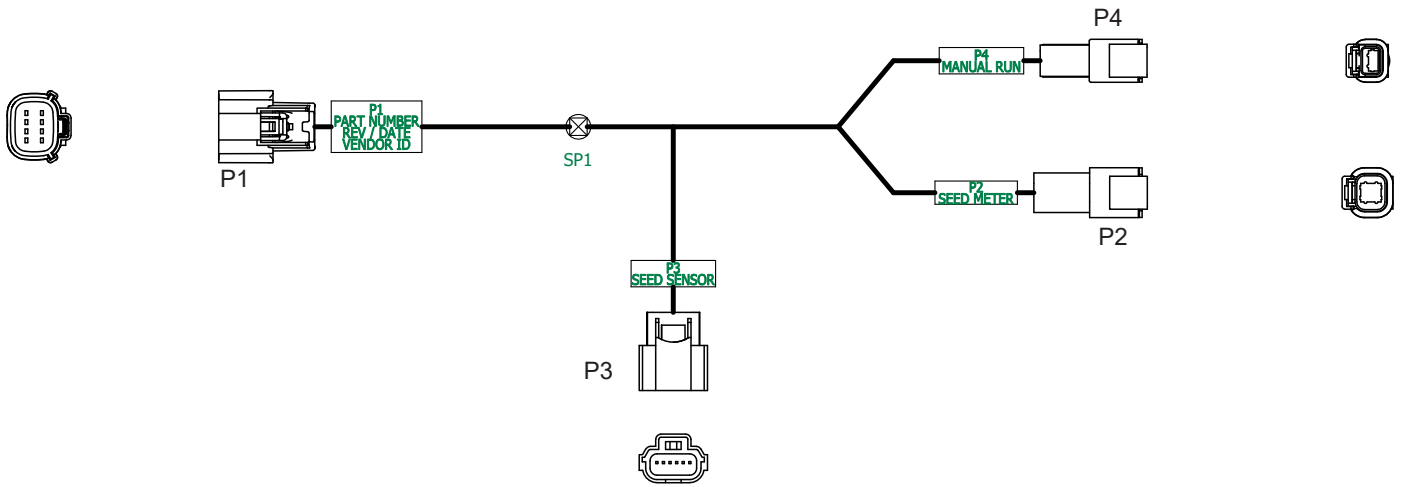

Wire Hookup Chart, P/N A25039

Reference Designator	From	To	Gauge	Color	Function
W1	P1-1	P2-1	18	Red	Seed Meter Motor 1+
W2	P1-2	P2-2	18	White	Seed Meter Motor 1-
W3	P1-3	P2-4	18	Black	Seed Meter Motor 2-
W4	P1-4	P2-3	18	Green	Seed Meter Motor 2+
W5	P1-5	P3-1	18	Red	Seed Sensor (Power)
W6	P1-6	SP1	18	Black	Ground
W7	P1-7	P3-2	18	Blue	Seed Sensor (Line)
W8	SP1	P3-6	18	Black	Seed Sensor (Ground)
W9		P4-1	18	Black	Manual Run (Ground)
W10	P1-8	P4-2	18	Red	Manual Run (Input)

Split Row RU Power Harness

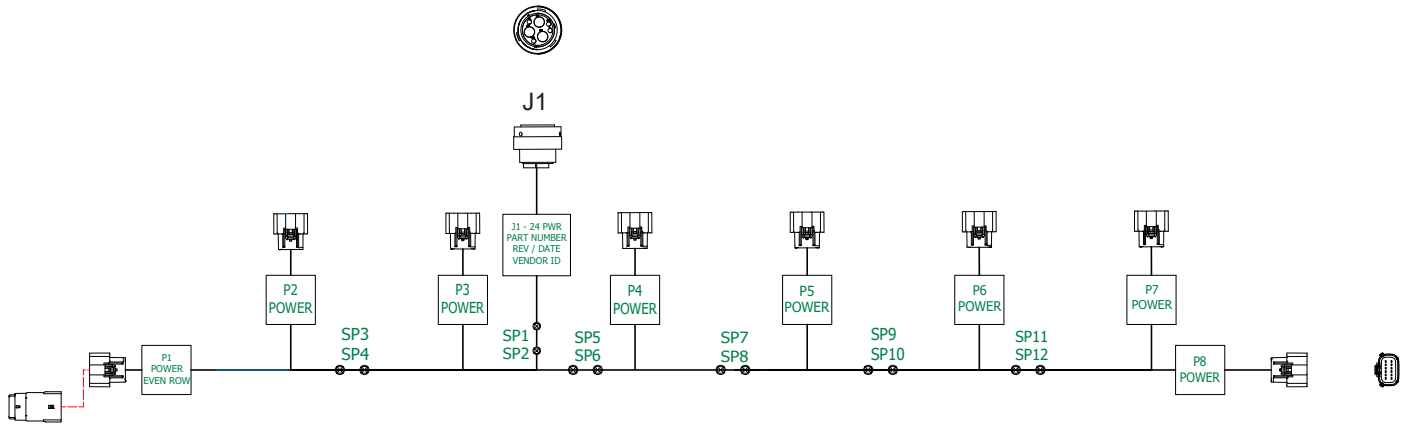

Wire Hookup Chart, P/N 10074701

Reference Designator	From	To	Gauge	Color	Function
W1	J1-6	SP1	8	Red	---
W2	J1-4	SP2	8	Black	---
W3	SP1	SP3	16	Red	---
W4	SP1	P3-1	18	Red	Row Unit 10 (Power)
W5	SP1	P3-3	18	Red	Row Unit 10 (Power)
W6	SP2	SP4	16	Black	---
W7	SP2	P3-2	18	Black	Row Unit 10 (Ground)
W8	SP2	P3-4	18	Black	Row Unit 10 (Ground)
W9	SP3	P1-1	18	Red	Even Row (Power)
W10	SP3	P1-3	18	Red	Even Row (Power)
W11	SP4	P1-2	18	Black	Even Row (Ground)
W12	SP4	P1-4	18	Black	Even Row (Ground)
W13	SP3	P2-1	18	Red	Row Unit 9 (Power)
W14	SP3	P2-3	18	Red	Row Unit 9 (Power)
W15	SP4	P2-2	18	Black	Row Unit 9 (Ground)
W16	SP4	P2-4	18	Black	Row Unit 9 (Ground)
W17	SP1	SP5	12	Red	---
W18	SP5	P4-1	18	Red	Row Unit 11 (Power)
W19	SP3	P4-3	18	Red	Row Unit 11 (Power)
W20	SP2	SP6	10	Black	---
W21	SP6	P4-2	18	Black	Row Unit 11 (Ground)
W22	SP6	P4-4	18	Black	Row Unit 11 (Ground)
W23	SP5	SP7	14	Red	---
W24	SP7	P5-1	18	Red	Row Unit 12 (Power)

(Continued on next page)

Wire Hookup Chart, P/N 10074701 (Continued)

Reference Designator	From	To	Gauge	Color	Function
W25	SP7	P5-3	18	Red	Row Unit 12 (Power)
W26	SP6	SP8	14	Black	---
W27	SP8	P5-2	18	Black	Row Unit 12 (Ground)
W28	SP8	P5-4	18	Black	Row Unit 12 (Ground)
W29	SP7	SP9	16	Red	---
W30	SP9	P6-1	18	Red	Row Unit 13 (Power)
W31	SP9	P6-3	18	Red	Row Unit 13 (Power)
W32	SP8	SP10	16	Black	---
W33	SP10	P6-2	18	Black	Row Unit 13 (Ground)
W34	SP10	P6-4	18	Black	Row Unit 13 (Ground)
W35	SP9	SP11	16	Red	---
W36	SP11	P7-1	18	Red	Row Unit 14 (Power)
W37	SP11	P7-3	18	Red	Row Unit 14 (Power)
W38	SP10	SP12	16	Black	---
W39	SP12	P7-2	18	Red	Row Unit 14 (Ground)
W40	SP12	P7-4	18	Red	Row Unit 14 (Ground)
W41	SP11	P8-1	18	Red	Row Unit 15 (Power)
W42	SP11	P8-3	18	Red	Row Unit 15 (Power)
W43	SP12	P8-2	18	Red	Row Unit 15 (Ground)
W44	SP12	P8-4	18	Red	Row Unit 15 (Ground)

Lights Harness

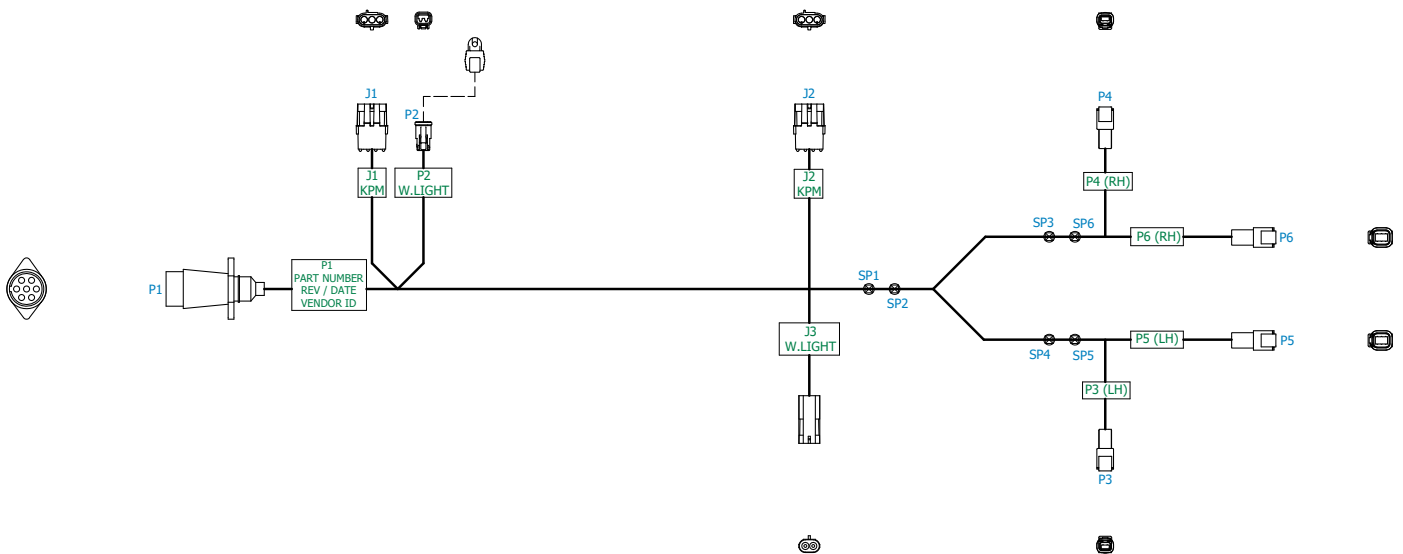

Wire Hookup Chart, P/N A25784

Reference Designator	From	To	Gauge	Color	Function
W1	J1-A	J2-A	14	White	Monitor + 12V (MUX)
W2	J1-B	J2-B	14	Black	Monitor Ground (MUX)
W3	J1-C	J2-C	14	Green	Monitor Data (MUX)
W4	P2-1	J3-B	14	White	Work Light + 12V
W5	P2-2	J3-A	14	Black	Work Light Ground
W6	P1-1	P5-4	16	Yellow	L.H. Flash
W7	P1-4	P6-4	16	Green	R.H. Flash
W8	P1-2	P5-5	16	Blue	Fog
W9	P1-3	SP1	16	White	Ground
W10	P1-6	SP2	16	Red	Stop Lights
W11	P1-5	SP3	16	Brown	R.H. Tail Light Power
W12	P1-7	SP4	16	Black	L.H. Tail Light Power
W13	SP1	SP5	16	White	Ground (L.H.)
W14	SP1	SP6	16	White	Ground (R.H.)
W15	SP2	P5-2	16	Red	Stop Lights (L.H.)
W16	SP2	P6-2	16	Red	Stop Lights (R.H.)
W17	SP3	P4-2	16	Brown	R.H. White Tail Light Power
W18	SP3	P6-3	16	Brown	R.H. White Tail Light Power
W19	SP4	P3-2	16	Black	L.H. White Tail Light Power
W20	SP4	P5-3	16	Black	L.H. Tail Light Power
W21	SP5	P3-1	16	White	L.H. White Tail Light Ground
W22	SP5	P5-6	16	White	L.H. Tail Light Ground
W23	SP6	P4-1	16	White	R.H. White Tail Light Ground
W24	SP6	P6-6	16	White	R.H. White Tail Light Ground

Worklight Harness

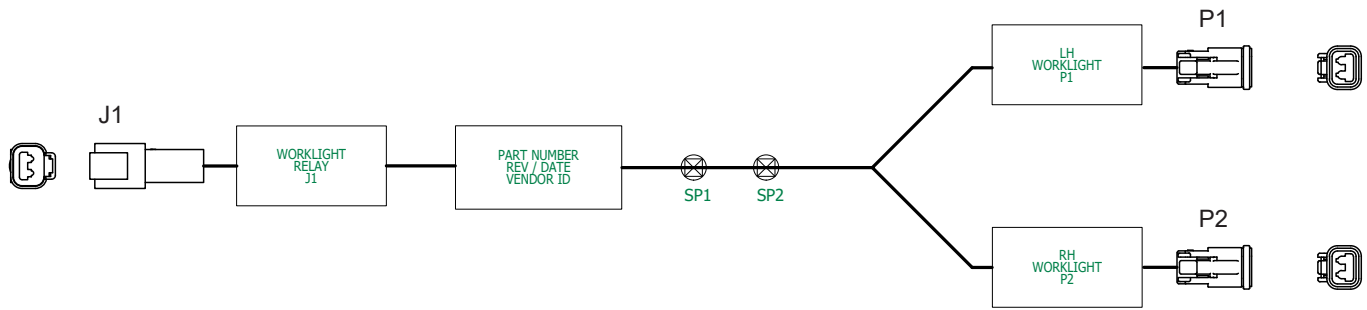

Wire Hookup Chart, P/N A26885

Reference Designator	From	To	Gauge	Color	Function
W1	J1-1	SP1	16	Black	12V DC-
W2	J1-2	SP2	16	Red	12V DC+
W3	SP1	P1-1	16	Black	Worklight (-)
W4	SP1	P2-1	16	Black	Worklight (-)
W5	SP2	P1-2	16	Red	Worklight (+)
W6	SP2	P2-2	16	Red	Worklight (+)

Planter Harness w/ Dust Caps (Ground Contact Drive)

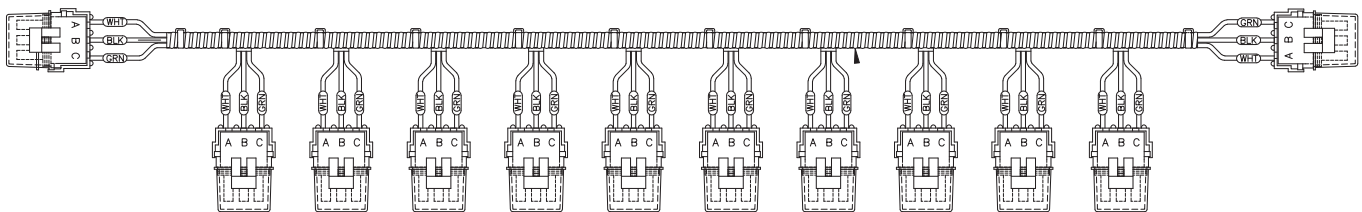

Row Unit Power Harness

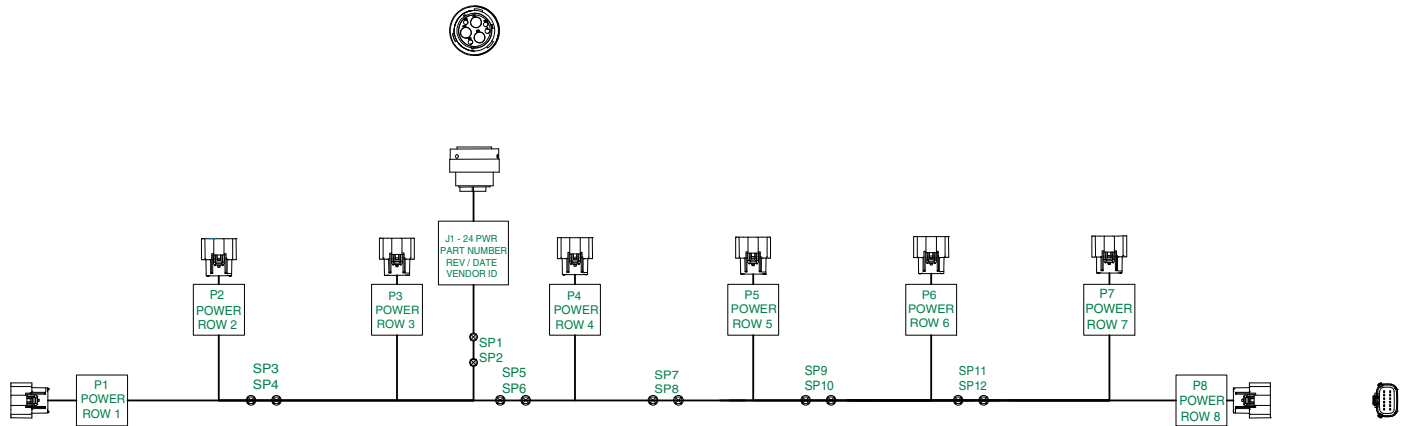

Wire Hookup Chart, P/N A26886

Reference Designator	From	To	Gauge	Color	Function
W1	J1-6	SP1	8	Red	---
W2	J1-4	SP2	8	Black	---
W3	SP1	SP3	16	Red	---
W4	SP1	P3-1	18	Red	Row Unit 3 (Power)
W5	SP1	P3-3	18	Red	Row Unit 3 (Power)
W6	SP2	SP4	16	Black	---
W7	SP2	P3-2	18	Black	Row Unit 3 (Ground)
W8	SP2	P3-4	18	Black	Row Unit 3 (Ground)
W9	SP3	P1-1	18	Red	Row Unit 1 (Power)
W10	SP3	P1-3	18	Red	Row Unit 1 (Power)
W11	SP4	P1-2	18	Black	Row Unit 1 (Ground)
W12	SP4	P1-4	18	Black	Row Unit 1 (Ground)
W13	SP3	P2-1	18	Red	Row Unit 2 (Power)
W14	SP3	P2-3	18	Red	Row Unit 2 (Power)
W15	SP4	P2-2	18	Black	Row Unit 2 (Ground)
W16	SP4	P2-4	18	Black	Row Unit 2 (Ground)
W17	SP1	SP5	10	Red	---
W18	SP5	P4-1	18	Red	Row Unit 4 (Power)
W19	SP3	P4-3	18	Red	Row Unit 4 (Power)
W20	SP2	SP6	10	Black	---
W21	SP6	P4-2	18	Black	Row Unit 4 (Ground)
W22	SP6	P4-4	18	Black	Row Unit 4 (Ground)
W23	SP5	SP7	14	Red	---
W24	SP7	P5-1	18	Red	Row Unit 5 (Power)
W25	SP7	P5-3	18	Red	Row Unit 5 (Power)

(Continued on next page)

Wire Hookup Chart, P/N A26886 (Continued)

Reference Designator	From	To	Gauge	Color	Function
W26	SP6	SP8	14	Black	---
W27	SP8	P5-2	18	Black	Row Unit 5 (Ground)
W28	SP8	P5-4	18	Black	Row Unit 5 (Ground)
W29	SP7	SP9	16	Red	---
W30	SP9	P6-1	18	Red	Row Unit 6 (Power)
W31	SP9	P6-3	18	Red	Row Unit 6 (Power)
W32	SP8	SP10	16	Black	---
W33	SP10	P6-2	18	Black	Row Unit 6 (Ground)
W34	SP10	P6-4	18	Black	Row Unit 6 (Ground)
W35	SP9	SP11	16	Red	---
W36	SP11	P7-1	18	Red	Row Unit 7 (Power)
W37	SP11	P7-3	18	Red	Row Unit 7 (Power)
W38	SP10	SP12	16	Black	---
W39	SP12	P7-2	18	Red	Row Unit 7 (Ground)
W40	SP12	P7-4	18	Red	Row Unit 7 (Ground)
W41	SP11	P8-1	18	Red	Row Unit 8 (Power)
W42	SP11	P8-3	18	Red	Row Unit 8 (Power)
W43	SP12	P8-2	18	Red	Row Unit 8 (Ground)
W44	SP12	P8-4	18	Red	Row Unit 8 (Ground)

Compressor Harness

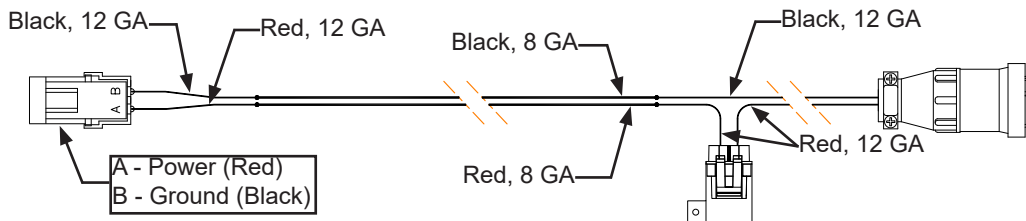

Row Unit Power Harness

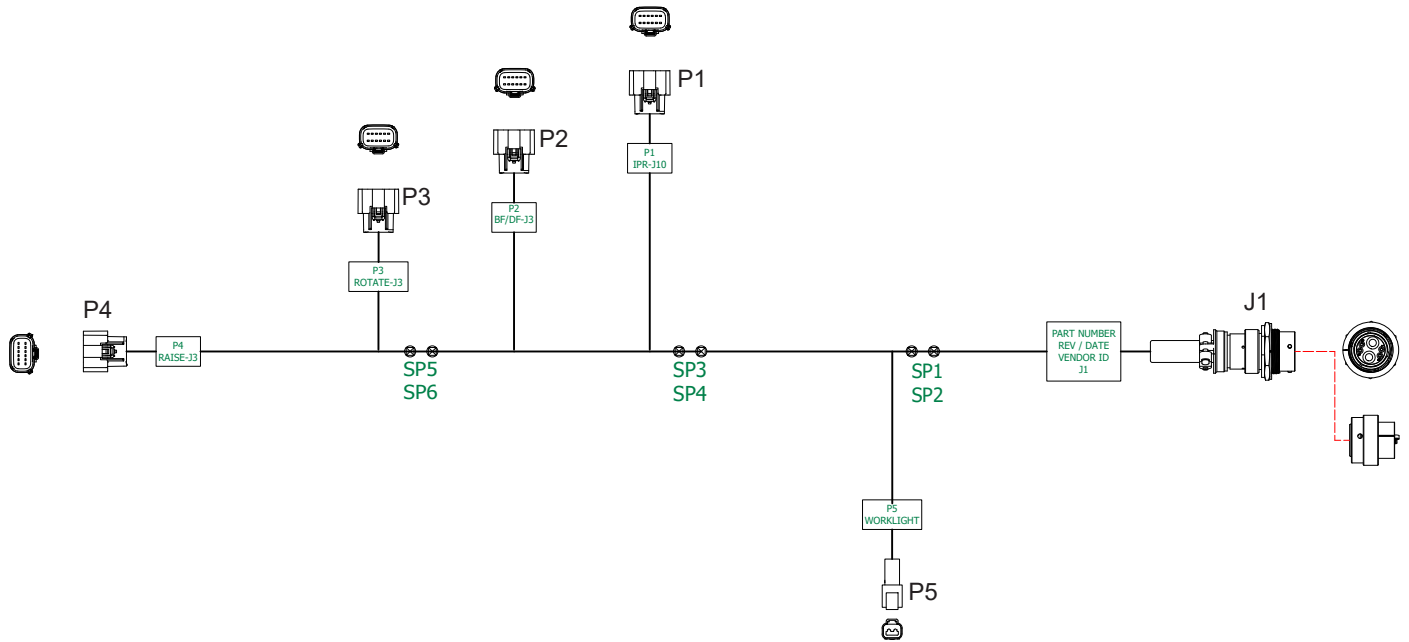

Wire Hookup Chart, P/N A25817

Reference Designator	From	To	Gauge	Color	Function
W1	J1-3	SP1	6	Red	12V DC (Power)
W2	J1-4	SP2	6	Black	12V DC (Ground)
W3	SP1	P5-2	16	Red	Worklight (Power)
W4	SP1	SP3	8	Red	12V DC (Power)
W5	SP2	P5-1	16	Black	Worklight (Ground)
W6	SP2	SP4	8	Black	12V DC (Ground)
W7	SP3	P1-1	18	Red	IPR (Power)
W8	SP3	P2-1	16	Red	BF/Dry Fertilizer IPN (Power)
W9	SP3	P2-3	16	Red	BF/Dry Fertilizer IPN (Power)
W10	SP3	SP5	12	Red	AUX IPN (Power)
W11	SP4	P1-2	18	Black	IPR (Ground)
W12	SP4	P2-2	16	Black	BF/Dry Fertilizer IPN (Ground)
W13	SP4	P2-4	16	Black	BF/Dry Fertilizer IPN (Ground)
W14	SP4	SP6	12	Black	AUX IPN (Ground)
W15	SP5	P3-1	16	Red	Rotation IPN (Power)
W16	SP5	P3-3	16	Red	Rotation IPN (Power)
W17	SP5	P4-1	16	Red	Raise IPN (Power)
W18	SP5	P4-3	16	Red	Raise IPN (Power)
W19	SP6	P3-2	16	Black	Rotation IPN (Power)
W20	SP6	P3-4	16	Black	Rotation IPN (Ground)
W21	SP6	P4-2	16	Black	Raise IPN (Ground)
W22	SP6	P4-4	16	Black	Raise IPN (Ground)

Rotation Harness

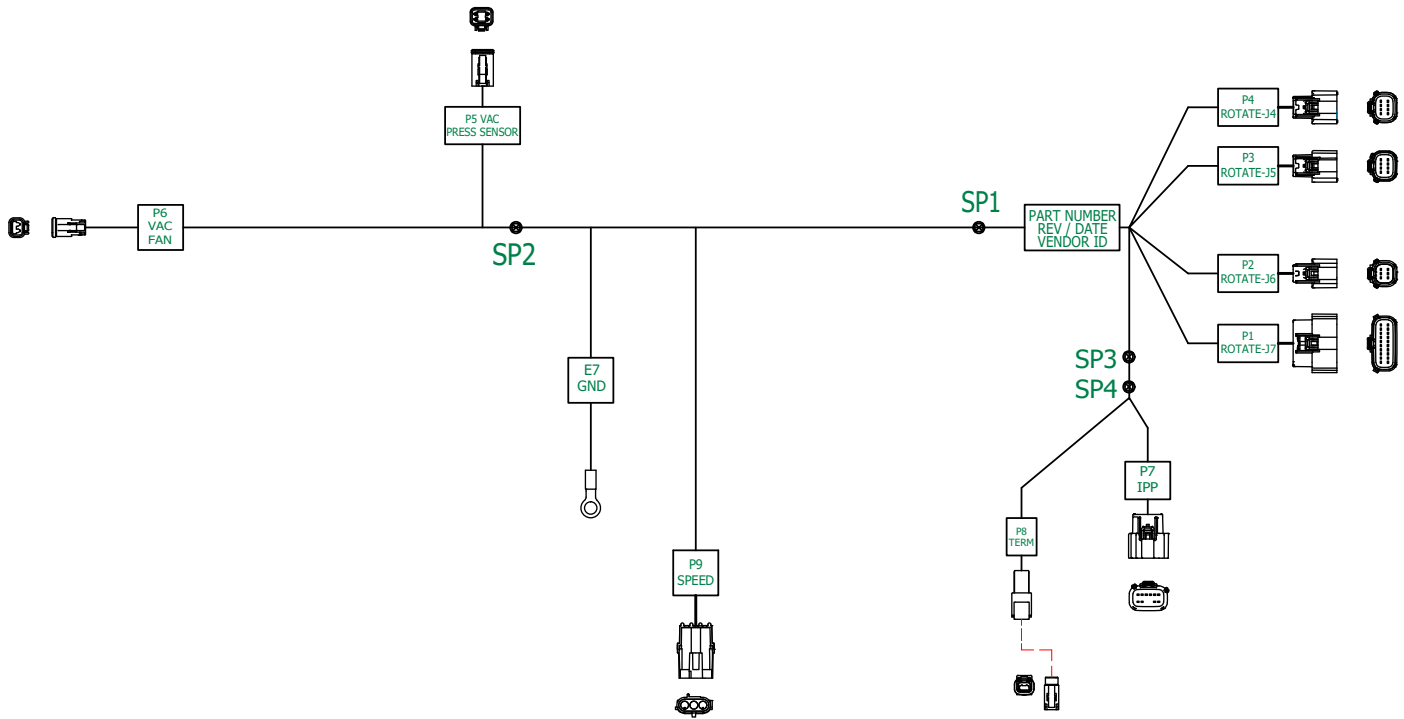

Wire Hookup Chart, P/N 10074801

Reference Designator	From	To	Gauge	Color	Function
W1	P1-1	P7-1	18	Orange	IPP RS232 RX
W2	P1-2	P7-2	18	Brown	IPP RS232 TX
W3	P1-3	P6-1	16	Red	VAC Solenoid (+)
W4	P1-4	P6-2	16	Black	VAC Solenoid (-)
W5	P1-14	P5-4	18	Yellow	VAC Pressure Sensor (SIG)
W6	P2-1	SP3	18	Yellow	IPP CAN HI
W7	P2-2	SP4	18	Green	IPP CAN LO
W8	P2-3	P7-12	16	Red	IPP Power +
W9	P2-4	P7-6	16	Black	IPP Power -
W10	P2-5	P7-11	18	Blue	IPP Boot
W11	P3-5	P5-2	18	White	VAC Pressure Sensor (Power)
W12	P3-6	SP2	18	Black	VAC Pressure Sensor (Ground)
W13	P3-7	P9-C	18	White	Wheel Speed (Frequency)
W14	P4-6	P9-B	18	Black	Wheel Speed (Ground)
W15	P4-5	P9-A	18	Red	Wheel Speed (Power)
W16	SP2	P5-1	18	Black	VAC Pressure Sensor (Ground)
W17	SP2	E7	18	Black	Planter Ground
W18	SP3	P7-5	18(TP)	Yellow	IPP CAN HI
W19	SP4	P7-4	18(TP)	GRN	IPP CAN LO
W20	SP3	P8-1	18(TP)	YEL	CAN HI Terminator
W21	SP4	P8-2	18(TP)	GRN	CAN LO Terminator

Raise Harness

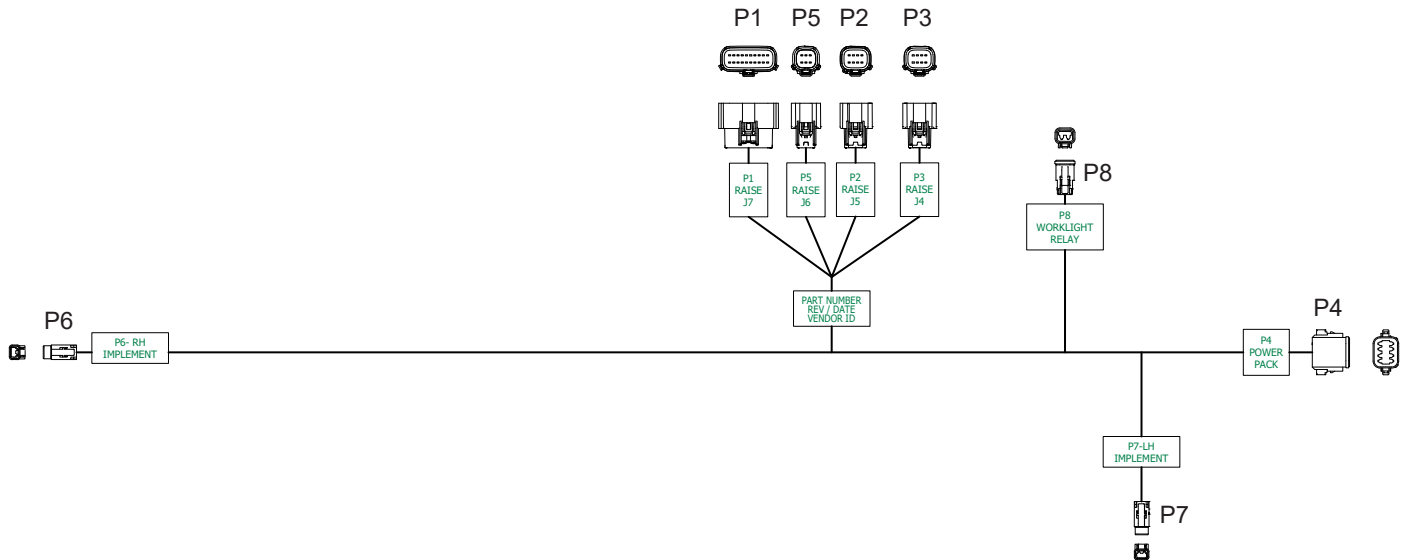

Wire Hookup Chart, P/N A26883

Reference Designator	From	To	Gauge	Color	Function
W1	P1-13	P4-4	20	Yellow	RU Power Feedback
W2	P1-14	P4-7	14	Orange	Battery #1 Voltage
W3	P1-16	P4-8	14	Blue	Battery #2 Voltage
W4	P1-17	P4-2	16	Black	RU Power Relay (Ground)
W5	P1-18	P4-1	16	Red	RU Power Relay (Power)
W6	P1-19	P8-1	16	Black	Worklight Relay (-)
W7	P1-20	P8-2	16	Red	Worklight Relay (+)
W8	P2-5	P6-1	18	Brown	R.H. Implement Switch (Power)
W9	P2-7	P6-2	18	Green	R.H. Implement Switch (Signal)
W10	P3-5	P7-1	18	Brown	L.H. Implement Switch (Power)
W11	P3-7	P7-2	18	Green	L.H. Implement Switch (Signal)
W12	P3-8	P4-3	16	Brown	Alternator sensor (Frequency)
W13	P5-5	P4-5	16	White	Battery Pack Relay (Power)
W14	P5-6	P4-6	16	Green	Battery Pack Relay (Ground)

Bulk Fill PDP Harness

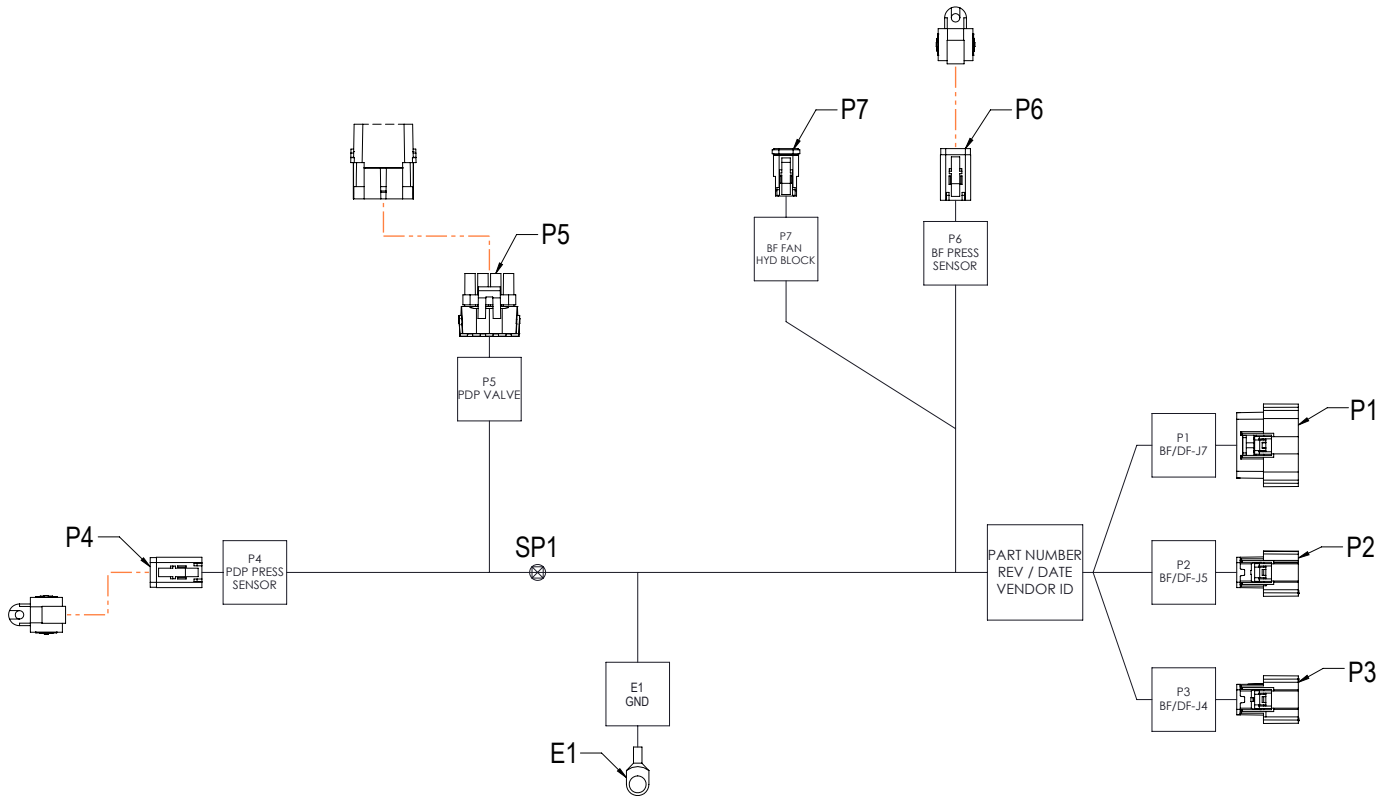

Wire Hookup Chart, P/N A26884

Reference Designator	From	To	Gauge	Color	Function
W1	P1-3	P5-C	16	Violet	PDP Decrease Solenoid (+)
W2	P1-4	P5-D	16	Brown	PDP Decrease Solenoid (-)
W3	P1-16	P4-4	18	White	PDP Sensor (Analog signal)
W4	P1-19	SP1	18	Black	PDP Sensor (Ground)
W5	P1-20	P4-2	18	Brown	PDP Sensor (Power)
W6	P2-1	P5-A	16	Red	PDP Increase Solenoid (+)
W7	P2-2	P5-B	16	Yellow	PDP Increase Solenoid (-)
W8	P2-5	P6-2	18	White	BF Pressure Sensor (Power)
W9	P2-6	P6-1	18	Black	BF Pressure Sensor (Ground)
W10	P2-7	P6-4	18	Yellow	BF Pressure Sensor (Analog signal)
W11	P3-1	P7-1	16	Red	BF Fan Solenoid (+)
W12	P3-2	P7-2	16	Black	BF Fan Solenoid (-)
W13	SP1	P4-1	18	Black	PDP Sensor (Ground)
W14	SP1	E1	18	Black	Ground

Row Unit Seed Meter Harness

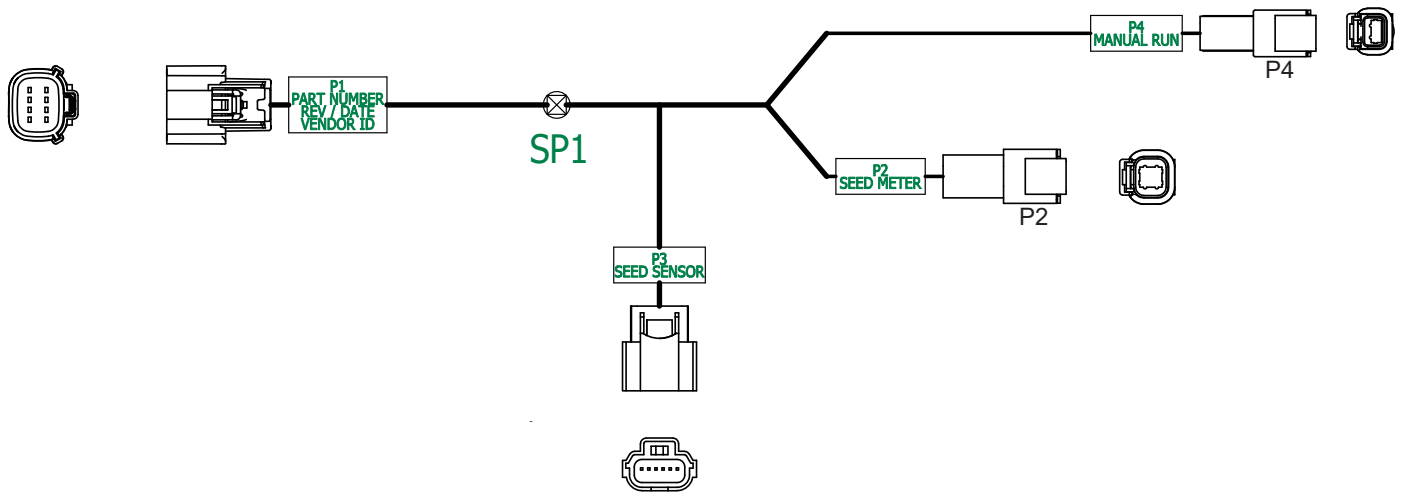

Wire Hookup Chart, P/N A25038

Reference Designator	From	To	Gauge	Color	Function
W1	P1-1	P2-1	18	Red	Seed Meter Motor #1, +
W2	P1-2	P2-2	18	White	Seed Meter Motor #1, -
W3	P1-3	P2-4	18	Black	Seed Meter Motor #2, -
W4	P1-4	P2-3	18	Green	Seed Meter Motor #2, +
W5	P1-5	P3-1	18	Red	Speed Sensor (Power)
W6	P1-6	SP1	18	Black	Ground
W7	P1-7	P3-2	18	Blue	Seed Sensor (Line)
W8	SP1	P3-6	18	Black	Seed Sensor (Ground)
W9		P4-1	18	Black	Manual Run (Ground)
W10	P1-8	P4-2	18	Red	Manual Run (Input)

Insecticide Harness

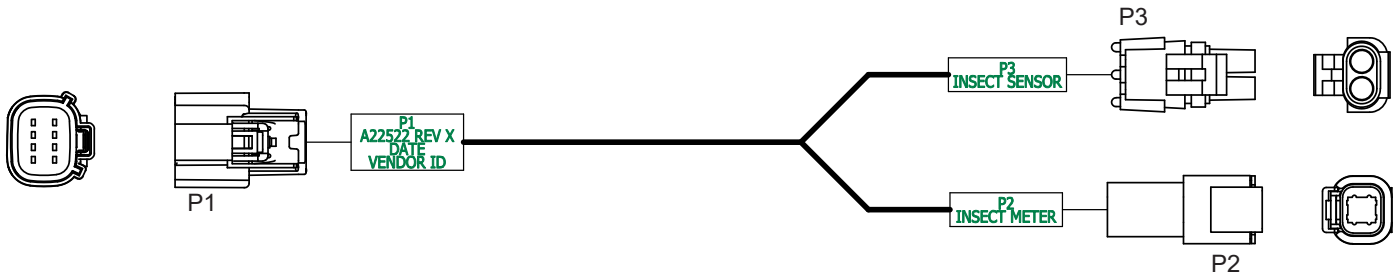

Wire Hookup Chart, P/N A22522

Reference Designator	From	To	Gauge	Color	Function
W1	P1-1	P2-1	18	Red	Insecticide Meter Motor #1, +
W2	P1-2	P2-2	18	White	Insecticide Meter Motor #1, -
W3	P1-3	P2-4	18	Black	Insecticide Meter Motor #2, -
W4	P1-4	P2-3	18	Green	Insecticide Meter Motor #2, +
W5	P1-6	P3-B	18	Black	Insecticide Sensor (Ground)
W6	P1-7	P3-A	18	Red	Insecticide Sensor (Power/Signal)

Seed Meter Motor ESD Drain Harness

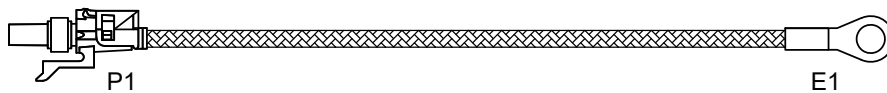

Row Unit ESD Drain Harness



Worklight Harness (Ground Contact Drive)

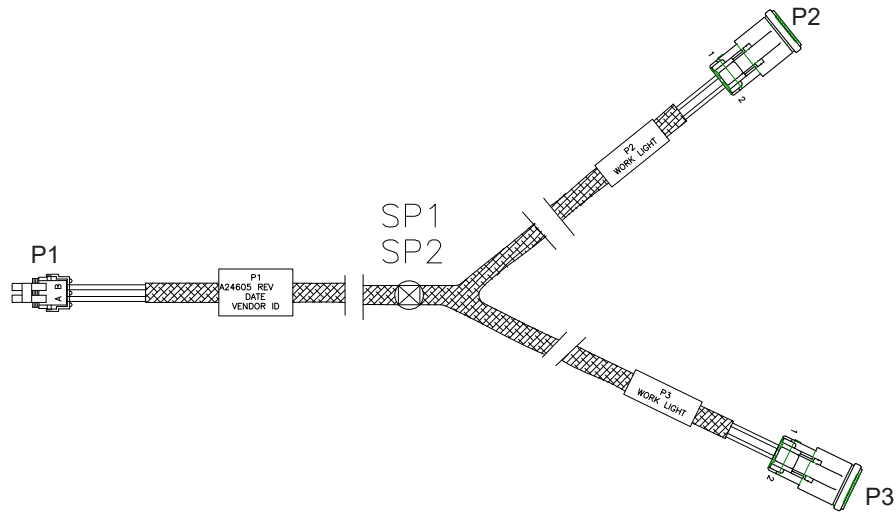

Wire Hookup Chart, P/N A24605

Reference Designator	From	To	Gauge	Color	Function
W1	P1-A	SP1	14	White	Ground
W2	P1-B	SP2	14	Black	Power
W3	SP1	P21	14	White	Ground
W4	SP1	P3-1	14	White	Ground
W5	SP2	P2-2	14	Black	Power
W6	SP2	P3-2	14	Black	Power

Worklight Switch Harness (Ground Contact Drive)

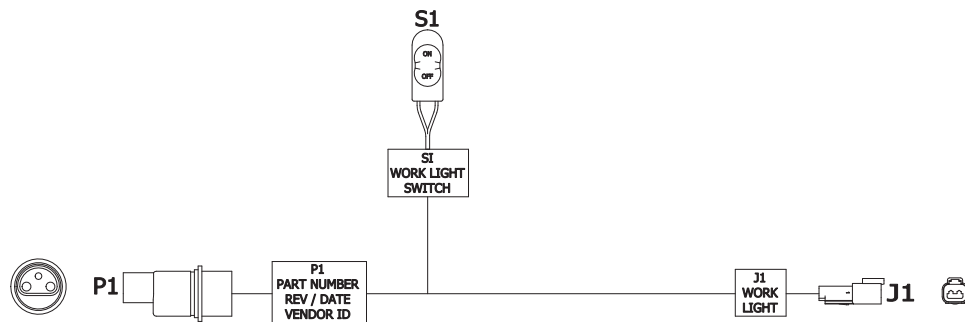

Wire Hookup Chart, P/N A25785

Reference Designator	From	To	Gauge	Color	Function
W1	P1-82	S1-1	14	Red	Tractor Power Switch
W3	P1-31	J1-2	14	White	Ground
W5	S1-2	J1-1	14	Black	Power Switch

'Y' Connector Harness (Ground Contact Drive)

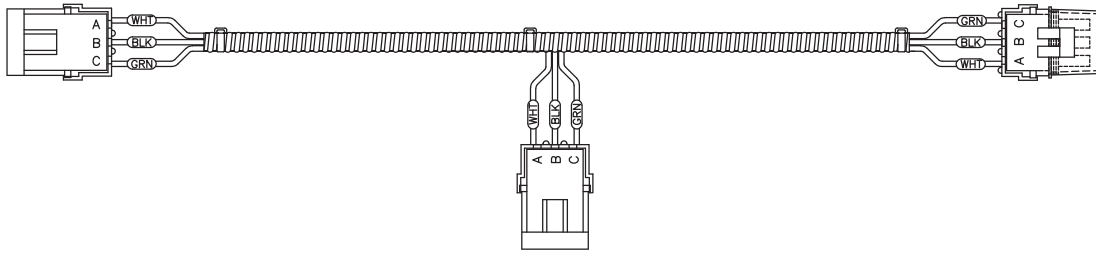

Cable Power Adapter (Ground Contact Drive)

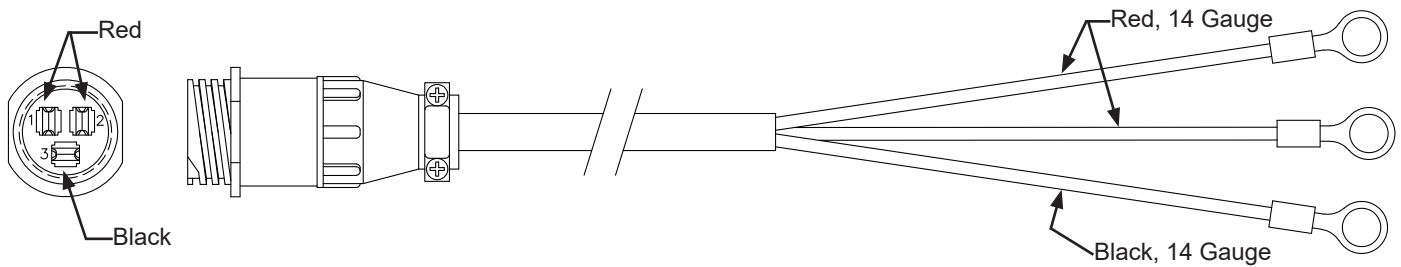

PDP Display Harness (Ground Contact Drive)

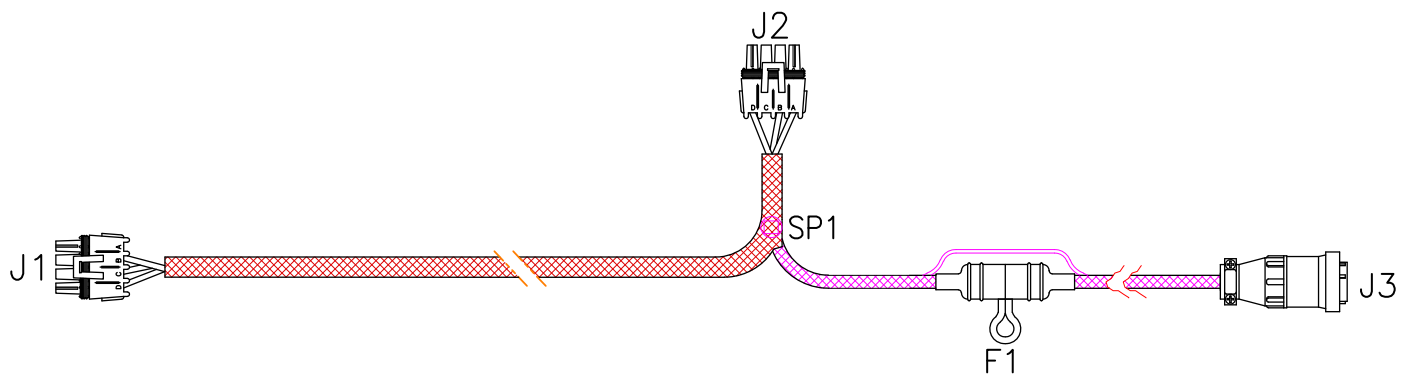

Wire Hookup Chart, P/N A13944

Reference Designator	From	To	Gauge	Color	Function
W1	11-A	12-A	16	Violet/White	Decrease
W2	11-B	SP1	16	Blue	Ground
W3	SP1	J3-3	16	Black	Ground
W4	11-C	12-C	16	Orange/White	Increase
W5	12-D	F1-1	16	Red	Power
W6	FI-2	13-1	16	Red	Power

Wiring Harness (Ground Contact Drive)

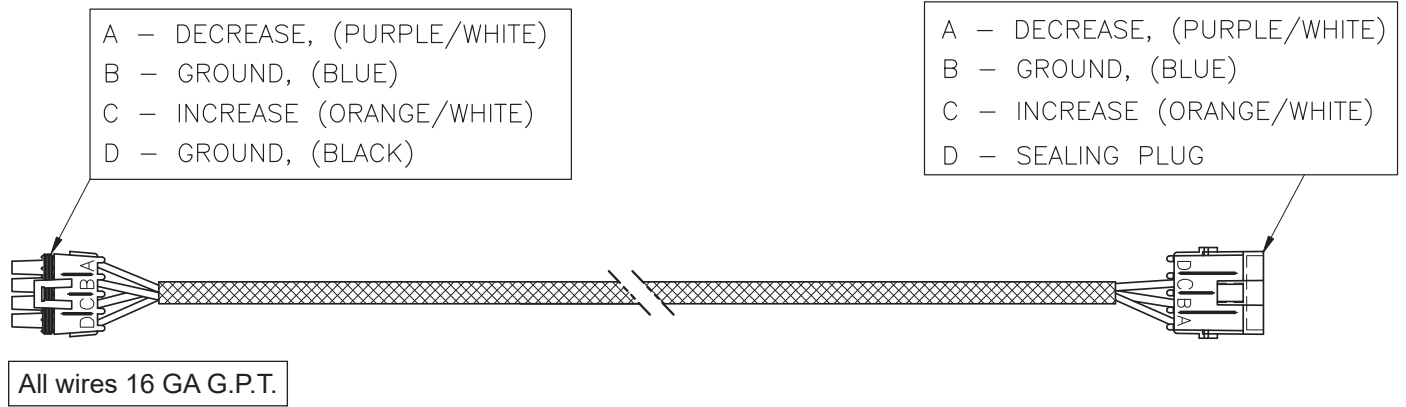

Tee Junction Harness (Ground Contact Drive)

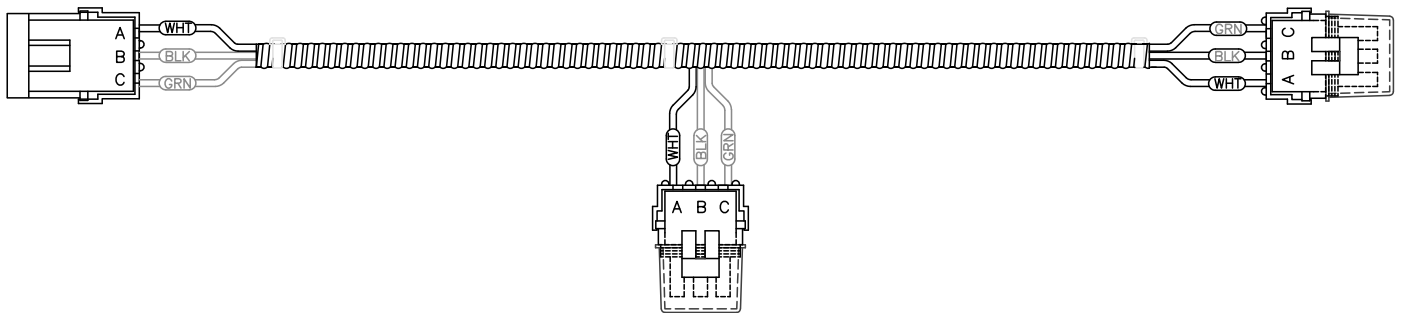

Implement Switch Extension Cable

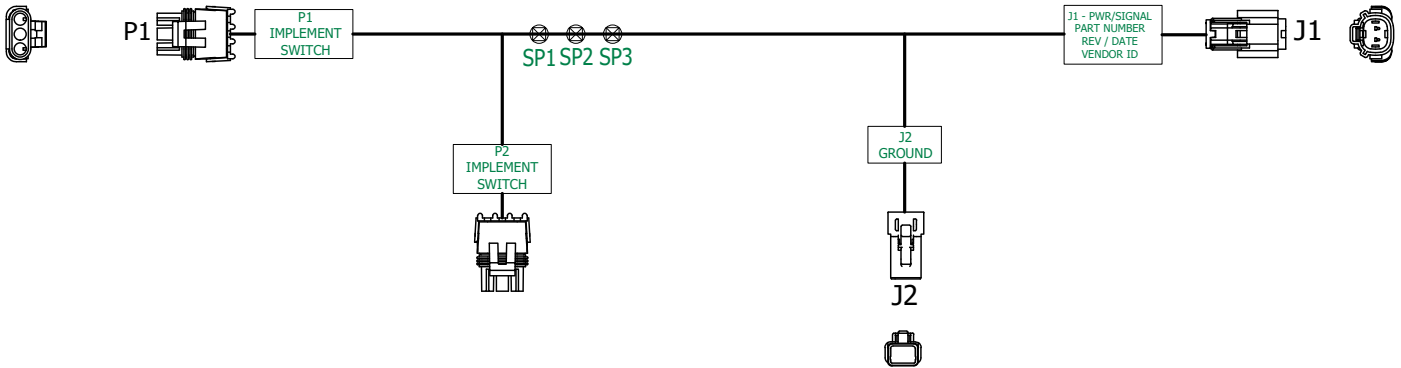

Wire Hookup Chart, P/N A25928

Reference Designator	From	To	Gauge	Color	Function
W1	J1-1	SP1	18	Brown	Load Power
W2	SP1	P1-A	18	Brown	Load Power
W3	SP1	P2-A	18	Brown	Load Power
W4	J1-2	SP2	18	Green	Switch IN
W5	SP2	P1-B	18	Green	Switch IN
W6	SP2	P2-B	18	Green	Switch IN
W7	J2-2	SP3	14	Blue	Ground
W8	SP3	P1-C	18	Blue	Ground
W9	SP3	P2-C	18	Blue	Ground

Clutch Harness (Ground Contact Drive)

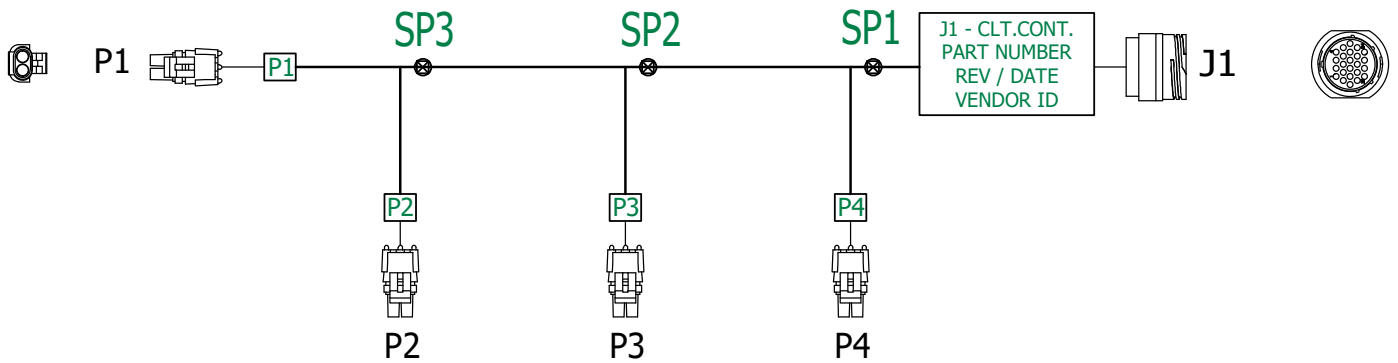

Wire Hookup Chart, P/N A25927

Reference Designator	From	To	Gauge	Color	Function
W1	J1-1	SP1	16	Black	Clutch Ground
W2	J1-2	P1-B	18	Green	Rpw 1 or 8
W3	J1-4	P2-B	18	Yellow	Row 2 or 7
W4	J1-6	P3-B	18	Blue	Row 3 or 6
W5	J1-8	P4-B	18	Violet	Row 4 or 5
W6	SP1	SP2	16	Black	Clutch Ground
W7	SP1	P4-A	18	Black	Clutch Ground
W8	SP2	SP3	16	Black	Clutch Ground
W9	SP2	P3-A	18	Black	Clutch Ground
W10	SP3	P1-A	18	Black	Clutch Ground
W11	SP2	P2-A	18	Black	Clutch Ground

BULK FILL TROUBLESHOOTING

PROBLEM	POSSIBLE CAUSE	SOLUTION
Seed does not travel through delivery tubes.	System pressure set too low.	Increase system pressure.
Seed stops flowing to row unit during planting.	Seed surging.	Shut down bulk fill system and restart system from idle; seed should start flowing.
	Debris in system.	Insert shutoff door, open cleanout door. remove plug.
Seed does not move from entrainer at startup after exposure to water.	Seed swelled in entrainer.	Insert shutoff door, open cleanout door. remove swelled seed.

CLOSING WHEEL TROUBLESHOOTING

PROBLEM	POSSIBLE CAUSE	SOLUTION
Closing wheel(s) leave severe imprint in soil.	Too much closing wheel down pressure.	Adjust closing wheel pressure.
Closing wheel(s) not firming soil around seed.	Insufficient closing wheel down pressure.	Adjust closing wheel pressure. Severe no till conditions may require use of cast iron closing wheels.
"V" closing wheel running on top of seed furrow.	Improper centering.	Align. See "V" Closing Wheel Adjustment (Rubber or Cast Iron)" on page 3-1
Single closing wheel not directly over seed.	Improper centering.	Align.

PISTON PUMP TROUBLESHOOTING

PROBLEM	POSSIBLE CAUSE	SOLUTION
Pump hard or impossible to prime.	Valves fouled or in wrong place.	Inspect and clean valves.
	Air leak in suction line.	Repair leak.
	Pump set too low.	Adjust pump setting.
	Packing washers worn out.	Replace.
Low metering.	Valves fouled or in wrong place.	Inspect and clean valves.
	Air leak in suction line.	Repair leak.
	Pump set too low.	Adjust pump setting.
	Broken valve spring.	Replace spring.
Over metering.	Broken discharge valve spring.	Replace spring.
	Trash under valves.	Inspect and clean valves.
	Improper rate setting.	Adjust pump setting.
Leaks through when stopped.	Broken discharge valve spring.	Replace spring.
	Trash under valves.	Inspect and clean valves.
Fertilizer solution leaking under stuffing box.	Packing washers worn out.	Replace.
Pump using excessive oil.	Oil seals or o-ring worn and leaking.	Replace.
Pump operates noisily.	Crankcase components worn excessively.	Inspect and replace if necessary.

PTO PUMP DRIVE AND OIL COOLER OPTION TROUBLESHOOTING

PROBLEM	POSSIBLE CAUSE	SOLUTION
Pump squealing.	Lack of oil to pump.	Check for plugged suction strainer.
	Air leak in suction line.	Check oil level.
Oil temperature is high.	Low oil level.	Check oil level and add as required.
Desired fan speed cannot be achieved.	Low oil level.	Check oil level and add as required.
	Plugged filter.	Check and change as required.
Vacuum level not displayed.	Digital vacuum gauge console power OFF.	Turn ON.
	Cable not plugged in.	Check connection.
	Digital vacuum gauge console has no power.	Check fuse.

ROW MARKER OPERATION TROUBLESHOOTING

PROBLEM	POSSIBLE CAUSE	SOLUTION
Both markers lowering and only one raising at a time.	Hoses from cylinders to valve connected backwards.	Check hosing diagram in manual and correct.
Same marker always operating.	Spool in sequencing valve not shifting.	Remove spool, inspect for foreign material, making sure all ports in spool are open. Clean and reinstall.
Both markers lower and raise at same time.	Foreign material under check ball in sequencing valve.	Remove hose fitting, spring and balls and clean. May be desirable to remove spool and clean as well.
	Check ball missing or installed incorrectly in sequencing valve.	Disassemble and correct. Refer to Lubrication and Maintenance section of this manual.
Marker (in raised position) settling down.	Damaged O-ring in marker cylinder or cracked piston.	Disassemble cylinder, inspect for damage, and repair.
	Spool in sequencing valve not shifting completely because detent ball or spring is missing.	Check valve assembly and install parts as needed.
	Spool in sequencing valve shifting back toward center position.	Restrict flow of hydraulic oil from tractor to sequencing valve.
Neither marker moves.	Flow control closed too far.	Loosen locking nut and turn flow control adjustment bolt out or counterclockwise until desired speed is set.
Markers moving too fast.	Flow control open too far.	Loosen locking nut and turn flow control adjustment bolt in or out until desired speed is set.
Sporadic marker operation speed.	Needle sticking open in flow control valve.	Remove flow control, inspect and repair, or replace.

SOLENOID VALVE

PROBLEM	POSSIBLE CAUSE	SOLUTION
No solenoids operate.	Low voltage.	Must be connected to 12 VDC only. Negative ground.
	Blown fuse.	Replace control console fuse with AGC-15 amp.
	Battery connection.	Clean and tighten.
	Wiring harness damaged.	Repair or replace.
One solenoid valve will not operate.	Bad switch.	Replace on control panel.
	Cut wire in harness.	Locate and repair.
	Bad coil.	Replace.
	Poor connection at coil.	Check.
Valve operating when not energized.	Valve stem stuck open.	Replace cartridge.
	O-ring leaking.	Install new O-ring kit.
	Foreign material under poppet.	Remove and clean cartridge.

VACUUM SEED METER

PROBLEM	POSSIBLE CAUSE	SOLUTION
Low seed count.	Meter RPM too high.	Reduce planting rate or planting speed.
	Singulator blade setting too aggressive.	Adjust singulator blade.
	Vacuum level too low.	Increase fan speed.
	Seed sensor not picking up all seeds dropped.	Clean seed tube. Move meter to different row.
	Seeds sticking to seed disc.	Use graphite or talc to aid release.
	Seed treatment buildup in seed disc recesses.	Reduce amount of treatment used and or mix thoroughly. Add talc.
	Seed size too large for disc used.	Use appropriate disc for seed size.
	Wrong seed disc.	Use appropriate disc for seed type and size.
	Failed/worn drive components.	Inspect and replace parts as required.
	Plugged orifices in seed disc.	Inspect and clean disc. Check remnant ejector.
	Loss of vacuum at meter.	Check for foreign material between vacuum cover and disc. Inspect parts for wear/damage. Clean or replace as required.
	Seed bridging in hopper.	Add graphite to improve seed flow.
	Faulty vacuum gauge reading.	Repair/replace gauge.
	Dirt in vacuum manifold.	Check vacuum manifold for dirt and clean.
	Seed baffle (If applicable) not allowing seed flow due to bridging of seed.	Mix talc thoroughly to coat all seeds. Remove seed baffle. See Row Unit Operation section.
	Seed disc worn.	Replace.
Vacuum seal worn.	Replace.	
Not planting seed.	Seed hoppers empty.	Fill seed hopper.
	Seed tube plugged/damaged.	Clean or replace tube.
	Meter drive damaged.	Repair/replace drive components.
	Low/no vacuum.	Inspect vacuum system and repair as necessary.
	Singulator blade setting too aggressive.	Adjust singulator blade.
	Faulty vacuum gauge.	Repair/replace vacuum gauge.
	Seed bridging in hopper.	Add graphite to improve seed flow.
	Loss of vacuum at meter.	Check for foreign material between vacuum cover and disc. Inspect parts for wear/ damage. Clean and/ or replace as required.
	Wrong seed disc.	Use appropriate disc for seed type and size.
	Meter drive clutch not engaged.	Engage drive clutch.
	Fan not running.	Start fan.
	Dirt in vacuum manifold.	Check vacuum manifold for dirt and clean.

Continued on next page.

VACUUM SEED METER - Continued

PROBLEM	POSSIBLE CAUSE	SOLUTION
Not planting seed. (Continued)	Seed baffle (if applicable) not allowing seed flow due to bridging of seed.	Mix talc thoroughly to coat all seeds. Remove seed baffle. Row Unit Operation section.
	High vacuum.	Adjust vacuum level to appropriate level.
	Wrong seed disc.	Replace seed disc.
	Singulator setting not aggressive enough.	Adjust singulator.
Poor seed spacing.	Faulty vacuum gauge.	Check gauge line for dirt/obstruction. Repair/replace vacuum gauge.
	Obstruction in seed tube.	Clean seed tube.
	Dirty/damaged seed disc.	Inspect seed disc for damage, foreign material in orifices or seed treatment buildup in recesses. Clean or replace.
	Wrong vacuum setting.	Adjust vacuum to appropriate level.
	Excess foreign material in seed.	Inspect and clean meter and seed discs. Use clean, undamaged seed.
	Incorrect singulator setting.	Adjust singulator to appropriate setting.
	Inconsistent driveline.	Inspect drive components for rust, misalignment, worn or damaged parts. Replace/repair as required.
	Toolbar not level or wrong height.	Adjust hitch to level toolbar and row units.
	Planting too fast for conditions.	Reduce speed.
Rough field conditions.	Reduce speed.	
Irregular seed population.	Driving too fast.	Reduce speed.
Unable to achieve desired vacuum level.	Tractor hydraulic flow set too low.	Increase flow to fan motor.
	Incorrect hydraulic connections.	Check all hydraulic connections and hose routings.
	Damaged fan components.	Inspect motor and impeller for wear/damage and repair/replace as necessary.
	Vacuum hose pinched/kinked/blocked.	Inspect air lines for any damage or obstruction. Clean air lines and manifold by removing end cap from manifold and running fan at high speed.
	Vacuum hose loose/disconnected.	Inspect and reattach all air hoses.
	Tractor not producing required hydraulic flow/pressure.	Have tractor serviced by qualified technician.
	Dirt in vacuum gauge line.	Check gauge line for dirt/obstruction and clean.