

# MODEL 3605 PIVOT FOLD EXPORT PLANTER OPERATOR'S MANUAL

**M0312-01**

**Rev. 02/25**

This manual is for:

Model 3605 Pivot Fold Planters

- 12 Row 70 CM "Y" Hitch; 2024 Production Year and on

- 16 Row 70 CM "Y" Hitch; 2024 Production Year and on

Record model number and serial number of your planter along with date purchased:

Model Number \_\_\_\_\_ 3605 \_\_\_\_\_

Serial Number \_\_\_\_\_

Date Purchased \_\_\_\_\_

Monitor Serial Number _____
Measured Pulses Per Mile/Km (Radar Distance Sensor) _____
Measured Pulses Per Mile/ Km (Magnetic Distance Sensor) _____

## SERIAL NUMBER

Record your serial number and purchase date above for quick reference.

The serial number provides important information about your planter and is required to obtain correct replacement parts. Always provide planter model and serial number to your Kinze Dealer when ordering parts or anytime correspondence is made with Kinze Manufacturing, Inc.



**Serial number plate location - Outer R.H. Wing  
(2021 Production And On)**



## EUROPEAN DECLARATION OF CONFORMITY

Kinze Manufacturing  
2172 M Avenue  
Williamsburg, IA 53261

Kinze Europe UAB  
Guopstu k., Senuju Traku sen  
LT-21148 Traku r., Lithuania

We, Kinze Manufacturing and Kinze Europe UAB declare, under our sole responsibility, the following products – agricultural planter models 3005, 3035, 3115, 3145, 3205, 3505, 3605, 3665, 3705, 4805, and 4905 – to which this declaration relates, are in conformity with the applicable provisions of the following standards, other normative documents and Directives, as appropriate by version and model:

2006/42/EC; EN 1037:1995+A1:2008; EN ISO 13850:2008; EN ISO 13857:2008; EN 349:1993+A1:2008; EN 547-1:1996+A1:2008; EN 547-2:1996+A1:2008; EN 547-3:1996+A1:2008; EN ISO 13732-1:2008; EN 614-1:2006+A1:2009; EN 614-2:2000+A1:2008; EN 953:1997+A1:2009; EN ISO 13849-1:2008; EN ISO 13849-2:2012; EN ISO 4254-1; EN ISO 12100:2010; EN ISO 4413:2010.

The Technical Construction File is maintained at: Kinze Manufacturing, Inc., 2172 M Avenue, Williamsburg, Iowa, USA, 52361-0806.

The authorized representative located within the community is: Edvardas Melys, Kinze Europe UAB, Guopstu k., Senuju Traku sen, LT-21148 Traku r., Lithuania.

Place of Issue: Kinze Manufacturing Inc., Williamsburg, Iowa, USA.

Date of Issue: 20200821 | August 21, 2020

Signed on behalf of Kinze Manufacturing Inc. and Kinze Europe UAB:

Jay D. Grimes

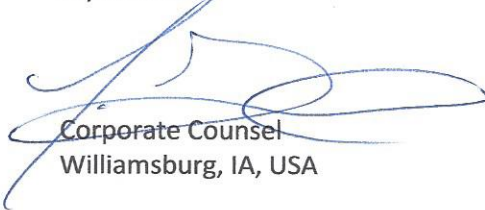

Corporate Counsel  
Williamsburg, IA, USA



**Kinze Manufacturing, Inc.**



## СЕРТИФИКАТ СООТВЕТСТВИЯ

№ ЕАЭС RU C-US.AД07.B.02342/20

Серия **RU** № **0225035**

**ОРГАН ПО СЕРТИФИКАЦИИ** Орган по сертификации Общество с ограниченной ответственностью «Центр Сертификации «ВЕЛЕС». Место нахождения (адрес юридического лица): 195009, РОССИЯ, город Санкт-Петербург, улица Академика Лебедева, дом 12, корпус 2, литера А, этаж 2, комната 26. Адрес места осуществления деятельности: 190068, РОССИЯ, город Санкт-Петербург, переулок Никольский, дом 4 литер А, помещение 8Н. Уникальный номер записи об аккредитации в реестре аккредитованных лиц № RA.RU.10АД07. Дата решения об аккредитации: 24.03.2016. Телефон: +74952211810 Адрес электронной почты: info@velessert.ru

**ЗАЯВИТЕЛЬ** ОБЩЕСТВО С ОГРАНИЧЕННОЙ ОТВЕТСТВЕННОСТЬЮ "МИР ТЕХНОЛОГИЙ"  
Место нахождения (адрес юридического лица) и адрес места осуществления деятельности: 117042, Россия, город Москва, улица Адмирала Руднева, дом 4, этаж 6, помещение IV, офис 613  
Основной государственный регистрационный номер 1187746469096.  
Телефон: 89154152183. Адрес электронной почты: MirTekhnology@gmail.com

**ИЗГОТОВИТЕЛЬ** KINZE Manufacturing, Inc.  
Место нахождения (адрес юридического лица): Соединенные Штаты, 2172 M Avenue, Williamsburg, IA 52631-0806  
Филиал изготовителя: KINZE Europe, UAB Литва, Guopstu kelias 17, Guopstos, LT-21148 Traku rajonas

**ПРОДУКЦИЯ** Машины сельскохозяйственные: сеялка точного высева торговой марки KINZE, моделей: 3000, 3005, 3030, 3035, 3110, 3115, 3140, 3145, 3200, 3205, 3500, 3505, 3600, 3605, 3660, 3665, 3700, 3705, 4700, 4705, 4800, 4805, 4900, 4905.  
Продукция изготовлена в соответствии с Директивой 2006/42/ЕС «Машины и механизмы».

Серийный выпуск

**КОД ТН ВЭД ЕАЭС** 8432311100

### СООТВЕТСТВУЕТ ТРЕБОВАНИЯМ

Технического регламента Таможенного союза "О безопасности машин и оборудования" (ТР ТС 010/2011)

**СЕРТИФИКАТ СООТВЕТСТВИЯ ВЫДАН НА ОСНОВАНИИ** протокола испытаний № 1023/3АТС-2020 от 27.10.2020 года, выданного Испытательной лабораторией «АвтоТракторные Средства» Общество с ограниченной ответственностью «ПРОММАШ ТЕСТ» (регистрационный номер аттестата аккредитации RA.RU.21НА71) акта анализа состояния производства от 21.09.2020 года, выданного Органом по сертификации Общество с ограниченной ответственностью «Центр Сертификации «ВЕЛЕС» обоснования безопасности; руководства по эксплуатации; паспорта

Схема сертификации: 1с

**ДОПОЛНИТЕЛЬНАЯ ИНФОРМАЦИЯ** ГОСТ Р 53489-2009 "Система стандартов безопасности труда. Машины сельскохозяйственные навесные и прицепные. Общие требования безопасности" разделы 4 и 5. Срок службы, срок и условия хранения указаны в эксплуатационной документации, приложенной к изделию.

**СРОК ДЕЙСТВИЯ С**  
**ВКЛЮЧИТЕЛЬНО**

28.10.2020

**ПО**

27.10.2025

Руководитель (уполномоченное  
лицо) органа по сертификации

Эксперт (эксперт-аудитор)  
(эксперты (эксперты-аудиторы))

*(подпись)*  
*(подпись)*



Родзиков Галина Александровна  
(Ф.И.О.)

Киреевко Константин Борисович  
(Ф.И.О.)



**TO THE DEALER**

Predelivery service includes assembly, lubrication, adjustment and test. This service helps ensure planter is delivered to retail customer/end user ready for field use.

**PREDELIVERY CHECKLIST**

Use the following checklist after planter is completely assembled. Check off each item as it is found satisfactory or after proper adjustment is made.

- Center pivot base mounting hex head cap screws torqued as specified in the manual.
- Row units properly spaced and optional attachments correctly assembled.
- Row marker assemblies installed and adjusted at each end of the planter.
- Vacuum is properly installed (as applicable).
- All grease fittings in place and lubricated.
- All working parts move freely, bolts are tight, and cotter pins are spread.
- Check all drive chains for proper tension and alignment.
- Check for oil leaks and proper hydraulic operation.
- Hydraulic hoses correctly routed to prevent damage.
- Inflate tires to specified air pressure and torque wheel lug bolts and lug nuts as specified in the manual.
- All safety decals correctly located and legible. Replace if damaged.
- All reflective decals and SMV sign correctly located and visible when the planter is in transport position.
- Safety/warning lights correctly installed and working properly.
- Paint all parts scratched during shipment or assembly.
- All safety lockup devices on the planter and correctly located.
- Auxiliary safety chain properly installed and hardware torqued to specification.
- Control box properly installed in tractor. All cables correctly routed and secure.

**Planter has been thoroughly checked and to the best of my knowledge is ready for delivery to the customer.**

(Signature Of Set-Up Person/Dealer Name/Date)

**OWNER REGISTER**

Name \_\_\_\_\_ Delivery Date \_\_\_\_\_

Street Address \_\_\_\_\_ Model No. 3605 Serial No. \_\_\_\_\_

City, State/Province \_\_\_\_\_ Dealer Name \_\_\_\_\_

ZIP/Postal Code \_\_\_\_\_ Dealer No. \_\_\_\_\_

---

## DELIVERY CHECKLIST

Use the following checklist at time planter is delivered as a reminder of very important information which should be conveyed to retail customer/end user. Check off each item as it is fully explained.

- Life expectancy of this or any other machine is dependent on regular lubrication as directed in the Operator Manual.
- All applicable safety precautions.
- Along with retail customer/end user, check reflective decals and SMV sign are clearly visible with planter in transport position and attached to tractor. Check safety/warning lights are in working condition. Tell retail customer/end user to check federal, state/provincial, and local regulations before towing or transporting on a road or highway.
- Give Operator Manual, Parts Manual, and all Instruction Sheets to retail customer/end user and explain all operating adjustments.
- Read warranty to retail customer/end user.
- Complete Warranty and Delivery Report form.

**To the best of my knowledge this machine has been delivered ready for field use and customer has been fully informed as to proper care and operation.**

---

(Signature Of Delivery Person/Dealer Name/Date)

## AFTER DELIVERY CHECKLIST

The following is a list of items we suggest checking during the first season of use of the equipment.

- Check planter performance with retail customer/end user.
- Check performance of vacuum seed metering system with retail customer/end user.
- Review importance of proper maintenance and adherence to all safety precautions with retail customer/end user.
- Check for parts that may need to be adjusted or replaced.
- Check all safety decals, reflective decals, and SMV sign are correctly located as shown in the Parts Manual and that decals are legible. Replace if damaged or missing.
- Check safety/warning lights are working properly.

---

(Signature Of Follow-Up Person/Dealer Name/Date)

**All registrations must be submitted online at "[business.kinze.com](http://business.kinze.com)" within 5 business days of delivery.  
Retain a copy of this form for auditing purposes.**

Tear Along Perforation

**OVERVIEW**

To The Owner .....	1-1
Warranty .....	1-3
General Information .....	1-4
Specifications .....	1-5
General Safety Rules .....	1-8
Safety Precautions .....	1-9
Safety Instructions, Signs, and Decals .....	1-10

**MACHINE OPERATION**

Manual Safety Lockup .....	2-1
Row Marker Safety Lockup .....	2-1
Tongue Safety Pin .....	2-2
Transport Latch Locking Pin .....	2-2
Initial Preparation .....	2-3
Tractor Requirements .....	2-4
Tractor Mounted PTO Pump And Oil Cooler Option .....	2-5
Oil Specification .....	2-5
Tractor Preparation and Hookup .....	2-6
Cylinder Information .....	2-10
Hydraulic Hose Information .....	2-12
Level Planter .....	2-17
Ridge Planting .....	2-18
Contact Wheel Drive Sprockets .....	2-19
Contact Wheel Spring Adjustment .....	2-20
Seed Rate Transmission Adjustment .....	2-20
Wrap Spring Wrench Operation .....	2-20
Shear Protection .....	2-21
Hydraulic/Electric Operation .....	2-22
Transport to Field Sequence .....	2-24
Field Operation .....	2-27
Planting Speed .....	2-27
Field to Transport Sequence .....	2-28
Transport to Field Sequence Using Blue Vantage .....	2-31
Vacuum System .....	2-32
Digital Vacuum Readout .....	2-32
Vacuum Fan Motor Valve Block Assembly .....	2-32
Analog Vacuum or Pressure Gauge .....	2-32
Bulk Fill System .....	2-33
Bulk Fill Entrainer Access .....	2-34
Bulk Fill Tanks - Clean Out .....	2-34
Bulk Fill Scale Package Option .....	2-35
Ag Leader Integra Display .....	2-39
Ag Leader Monitoring Control (PMM) .....	2-39
Ag Leader InCommand 1200 Display .....	2-39
Kinze Blue Vantage .....	2-39
Row Marker Operation .....	2-40
Row Marker Speed Adjustment .....	2-41

Even-Row Push Row Unit .....	2-41
Row Marker Adjustments .....	2-42
Row Marker Even-Row Length Adjustment .....	2-43
Offset Hitch Adjustment .....	2-43
Point Row Clutches .....	2-44
Auxiliary Hydraulic Option .....	2-45
Field Test .....	2-46
Field Check Seed Population .....	2-46
Field Check Granular Chemical Application .....	2-48
Water Tank .....	2-49

**ROW UNIT OPERATION**

Planting Depth .....	3-1
"V" Closing Wheel Adjustment (Rubber or Cast Iron) .....	3-1
Row Unit Extension Brackets .....	3-2
Seed Hoppers .....	3-2
Seed Meter Drive Release .....	3-2
Row Unit Chain Routing .....	3-3
Quick Adjustable Down Force Springs Option .....	3-4
Pneumatic Down Pressure Package Option .....	3-5
Split Row Push Row Unit Clutch Sprocket .....	3-8
Split Row Push Row Unit Vacuum Hose Shutoff .....	3-8
Split Row Lockups .....	3-9
Vacuum Settings .....	3-12
Wheat Disc Wiper Installation .....	3-14
Rapeseed Planting Section .....	3-16
Seed Meter Cleanout .....	3-20
Additives .....	3-20
Row Unit Mounted Residue Wheel .....	3-22
Row Unit Mounted No Till Coulter .....	3-23
Coulter Mounted Residue Wheels .....	3-23
Spiked Closing Wheel .....	3-24
Granular Chemical Hopper and Drive .....	3-25
Granular Chemical Banding Options .....	3-26
Granular Chemical Bander Shield .....	3-26

**FERTILIZER**

Double Disc Fertilizer Opener .....	4-1
Notched Single Disc Opener .....	4-2
Residue Wheel Attachment for Notched Single Disc Fertilizer Opener .....	4-4
Depth/Gauge Wheel Attachment for Notched Single Disc Fertilizer Opener .....	4-4
HD Single Disc Fertilizer Opener .....	4-5
Dry Fertilizer Attachment .....	4-7
Liquid Fertilizer Attachment .....	4-9
Liquid Fertilizer System Schematics .....	4-16
System Overview .....	4-17

Row Flow meter . . . . . 4-23  
 Row Flow Meter Cleanout . . . . . 4-24  
 Row Flow meter Jet Orifice Removal . . . . . 4-25  
 Row Flow meter Jet Orifice Installation . . . . . 4-27  
 Flow meter Strainer and Orifice Cleaning  
 and/or Replacement . . . . . 4-29  
 Orifice Configuration Rates . . . . . 4-31  
 Pump Clean Out and Storage . . . . . 4-33  
 In Furrow . . . . . 4-36  
 Liquid Fertilizer 3-Way Distribution Valves . . . . . 4-37  
 Liquid Fertilizer Sensors . . . . . 4-38  
 Fertilizer Pump Troubleshooting . . . . . 4-39  
 Fertilizer System Troubleshooting . . . . . 4-40

**RATE CHARTS . . . . . 5-1**

**LUBRICATION AND MAINTENANCE**

Lubrication . . . . . 6-1  
 Lubrication Symbols . . . . . 6-1  
 Sealed Bearings . . . . . 6-1  
 Wrap Spring Wrench Assembly . . . . . 6-1  
 Drive Chains . . . . . 6-2  
 Bushings . . . . . 6-3  
 Center Post . . . . . 6-5  
 U-Joint Slides . . . . . 6-5  
 Wheel Bearings . . . . . 6-6  
 Liquid Fertilizer Piston Pump . . . . . 6-6  
 Crankcase Oil Level . . . . . 6-6  
 Grease Fittings . . . . . 6-6  
 PTO Pump Shaft and Tractor PTO Shaft . . . . . 6-9  
 Mounting Bolts and Hardware . . . . . 6-10  
 Tire Servicing . . . . . 6-12  
 Vacuum Seed Meter Maintenance . . . . . 6-13  
 Seed Meter Cleanout . . . . . 6-13  
 Chain Tension Adjustment . . . . . 6-14  
 Gauge Wheel Adjustment . . . . . 6-14  
 Gauge Wheel Arm Bushing/Seal Replacement . . . . . 6-15  
 Gauge Wheel Arm Pivot Spindle Replacement . . . . . 6-16  
 15" Seed Opener Disc Blade/Bearing Assembly . . . . . 6-17  
 Seed Tube Guard/Inner Scraper . . . . . 6-19  
 Row Unit Mounted No Till Coulter . . . . . 6-20  
 Coulter Mounted Residue Wheels . . . . . 6-21  
 Row Unit Mounted Residue Wheel . . . . . 6-21  
 Granular Chemical Attachment . . . . . 6-21  
 Point Row Clutch Maintenance . . . . . 6-22  
 Check Valve (Lift System) . . . . . 6-24  
 Check Valve (Vacuum Fan) . . . . . 6-24  
 Flow Control Valve . . . . . 6-24

Pressure Relief Valve . . . . . 6-24  
 Pressure Reducing Relief Valve . . . . . 6-24  
 Relief Valve Cartridge . . . . . 6-24  
 Solenoid Valve . . . . . 6-25  
 Row Marker Bearing Lubrication or Replacement . . . . . 6-26  
 Row Marker Transport Stand Adjustment . . . . . 6-27  
 Wheel Bearing Repack or Replacement . . . . . 6-27  
 Wear Pad Field Replacement/Adjustment . . . . . 6-28  
 Tractor Mounted PTO Pump and Oil Cooler Option . . . . . 6-32  
 True Depth Hydraulic System Servicing . . . . . 6-33  
 True Depth Filter . . . . . 6-34  
 Pneumatic Down Pressure Air Compressor Tank . . . . . 6-36  
 Fertilizer Check Valve Cleaning and Repair . . . . . 6-36  
 Piston Pump Maintenance . . . . . 6-36  
 Piston Pump Storage . . . . . 6-37  
 Diaphragm Liquid Fertilizer Pump Maintenance . . . . . 6-38  
 Other diaphragm pump maintenance intervals . . . . . 6-39  
 Battery Care . . . . . 6-40  
 Electrical Control Console Schematic . . . . . 6-41  
 Electrical Wiring Harness Schematic (On Tractor) . . . . . 6-42  
 Electrical Wiring Harness Schematic (On Planter) . . . . . 6-43  
 Electrical Control Console Connections - AG Leader . . . . . 6-44  
 Valve Block - Located on Hitch . . . . . 6-46  
 Valve Block - Located on Rear Center Frame . . . . . 6-47  
 Hydraulic Hose Life . . . . . 6-48  
 Hydraulic System Schematic . . . . . 6-49  
 Hydraulic Schematic - Vacuum Fan Motor System . . . . . 6-52  
 Wing Down Pressure Schematic  
 (Weight Transfer Mechanism) . . . . . 6-53  
 True Depth Hydraulic Schematic, 16 Row . . . . . 6-54  
 True Depth Hydraulic Schematic, 12 Row . . . . . 6-55  
 Power Pack Wiring Diagram (Blue Drive) . . . . . 6-56  
 Cables and Harnesses . . . . . 6-57

**TROUBLESHOOTING**

Bulk Fill . . . . . 7-1  
 Closing Wheel . . . . . 7-1  
 Lift Circuit . . . . . 7-2  
 PTO Pump Drive and Oil Cooler Option . . . . . 7-3  
 Point Row Clutch . . . . . 7-3  
 Rotation Circuit . . . . . 7-4  
 Row Marker Operation . . . . . 7-4  
 Solenoid Valve . . . . . 7-5  
 Wing Lock Cylinder Circuit . . . . . 7-5  
 Seed Meter (Vacuum) . . . . . 7-6  
 Tongue Cylinder Circuit . . . . . 7-8  
 Diaphragm Fertilizer Pump . . . . . 7-9





Kinze Manufacturing, Inc. thanks you for your patronage. We appreciate your confidence in Kinze farm machinery. Your Kinze planter has been carefully designed to provide dependable operation in return for your investment.

**This manual has been prepared to aid you in the operation and maintenance of the planter. It should be considered a permanent part of the machine and remain with the machine when you sell it.**

It is the responsibility of the user to read and understand the Operator Manual in regards to safety, operation, lubrication and maintenance before operation of this equipment. It is the user's responsibility to inspect and service the machine routinely as directed in the Operator Manual. We have attempted to cover all areas of safety, operation, lubrication and maintenance; however, there may be times when special care must be taken to fit your conditions.

Throughout this manual the symbol  and the words **DANGER**, **WARNING**, and **CAUTION** are used to call attention to safety information that if not followed, will or could result in death or injury. **NOTICE** and **NOTE** are used to call your attention to important information. The definition of each of these terms follows:

 <b>DANGER</b>	<p>Indicates an imminently hazardous situation that, if not avoided, will result in death or serious injury. This signal word is to be limited to the most extreme situations, typically for machine components which, for functional purposes, cannot be guarded.</p>
 <b>WARNING</b>	<p>Indicates a potentially hazardous situation that, if not avoided, could result in death or serious injury, and includes hazards that are exposed when guards are removed. It may also be used to alert against unsafe practices.</p>
 <b>CAUTION</b>	<p>Indicates a potentially hazardous situation that, if not avoided, may result in minor or moderate injury. It may also be used to alert against unsafe practices.</p>
<b>NOTICE</b>	<p>Used to address safety practices not related to personal injury.</p>

**NOTE:** Special point of information or machine adjustment instructions.

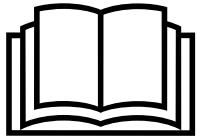

Improperly operating or working on this equipment could result in death or serious injury. Read and follow all instructions in Operator Manual before operating or working on this equipment.



Some photos in this manual may show safety covers, shields, or lockup devices removed for visual clarity. **NEVER OPERATOR OR WORK ON** machine without all safety covers, shields, and lockup device in place as required.

**NOTE:** Some photos in this manual may have been taken of prototype machines. Production machines may vary in appearance.

**NOTE:** Some photos and illustrations in this manual show optional attachments installed. Contact your Kinze Dealer for purchase of optional attachments.

The Kinze Limited Warranty for your new machine is stated on the retail purchaser's copy of the Warranty And Delivery Receipt form. Additional copies of the Limited Warranty can be obtained through your Kinze Dealer.

Warranty, within the warranty period, is provided as part of Kinze's support program for registered Kinze products which have been operated and maintained as described in this manual. Evidence of equipment abuse or modification beyond original factory specifications will void the warranty. Normal maintenance, service and repair is not covered by Kinze warranty.

To register your Kinze product for warranty, a Warranty And Delivery Receipt form must be completed by the Kinze Dealer and signed by the retail purchaser, with copies to the Dealer, and to the retail purchaser. Registration must be completed and submitted to Kinze Manufacturing, Inc. within 5 business days of delivery of the Kinze product to the retail purchaser. Kinze Manufacturing, Inc. reserves the right to refuse warranty on serial numbered products which have not been properly registered.

If service or replacement of failed parts which are covered by the Limited Warranty are required, it is the user's responsibility to deliver the machine along with the retail purchaser's copy of the Warranty And Delivery Receipt to the Kinze Dealer for service. Kinze warranty does not include cost of travel time, mileage, hauling or labor. Any prior arrangement made between the Dealer and the retail purchaser in which the Dealer agrees to absorb all or part of this expense should be considered a courtesy to the retail purchaser.

Kinze warranty does not include cost of travel time, mileage, hauling, or labor.



**Model 3605 16 Row Planter with Vacuum, Split Rows, and Bulk Fill System**

The Model 3605 Twin-Line Planter is available with vacuum meters, row hoppers or bulk fill, split rows, and various other options. Liquid or dry fertilizer application equipment and various row unit attachments are also available.

Information used in these instructions was current at time of printing. However, due to Kinze's ongoing product improvement, production changes may cause your machine to appear slightly different in detail. Kinze Manufacturing, Inc. reserves the right to change specifications or design without notice and without incurring obligation to install the same on machines previously manufactured.

Right hand (R.H.) and left hand (L.H.), as used throughout this manual, are determined by facing direction machine travels in use unless otherwise stated.

## TOOLS REQUIRED

Hardware Size / Tool Required			
$\frac{1}{4}" = \frac{7}{16}"$	$\frac{7}{16}" = \frac{5}{8}"$ (nut for $\frac{7}{16}"$ hardware uses $\frac{1}{16}"$ tool)	$\frac{3}{4}" = 1\frac{1}{8}"$	$1\frac{1}{4}" = 1\frac{7}{8}"$
$\frac{5}{16}" = \frac{1}{2}"$	$\frac{1}{2}" = \frac{3}{4}"$	$\frac{7}{8}" = 1\frac{5}{16}"$	$1\frac{1}{2}" = 2\frac{1}{4}"$
$\frac{3}{8}" = \frac{9}{16}"$	$\frac{5}{8}" = 1\frac{5}{16}"$	$1" = 1\frac{1}{2}"$	

Specification	Row Hoppers	
	12R 70 CM Y	16R 70 CM Y
Number of Rows	12R 70 CM Y	16R 70 CM Y
Base Machine (Empty)*	12,780-13,185 lb (5795-5980 kg)	15,730-16,210 lb (7135-7350 kg)
Transport Height	11' 4" (3.50 m)	11' 4" (3.50 m)
Planting Length	21' 0" (6.40 m)	23' 11" (7.30 m)
Transport Length	34' 5" (10.50 m)	43' 8" (13.30 m)
Planting Width	29' 6" (9.00 m)	38' 5" (11.70 m)
Transport Width	10' 6" (3.20 m)	10' 6" (3.20 m)
Seed Capacity	1.75 bu (62 L)/Hopper (Vacuum);	1.75 bu (62 L)/Hopper (Vacuum);
Transport Tire Size	9" x 22.5" 14PR	
Field Tire Size	7.50" x 20" 8 ply rib implement tires w/o center groove.	
Field Lift	Two master/two slave rephasing cylinders.	
Row Markers	Independently controlled, three stage, low profile, w/disk blade depth bands.	

Specification	Bulk Fill	
	12R 70 CM Y	16R 70 CM Y
Number of Rows	12R 70 CM Y	16R 70 CM Y
Base Machine (Empty)*	14,590-15,242 lb (6615-6915 kg)	15,600-17,048 lb (7075-7730 kg)
Transport Height	12' 5" (3.80 m)	12' 5" (3.80 m)
Planting Length	21' 0" (6.40 m)	23' 11" (7.30 m)
Transport Length	34' 5" (10.50 m)	43' 8" (13.30 m)
Planting Width	29' 6" (9.00 m)	38' 5" (11.70 m)
Transport Width	10' 6" (3.20 m)	10' 6" (3.20 m)
Seed Capacity	80 bu (2819 L)	
Transport Tire Size	9" x 22.5" 14PR	
Field Tire Size	7.50" x 20" 8 ply rib implement tires w/o center groove.	
Field Lift	Two master/two slave rephasing cylinders.	
Row Markers	Independently controlled, three stage, low profile, w/disk blade depth bands.	
*Base machine weight depending on how machine is equipped (meters, drives, and hoppers).		

<b>KINZE 3605 70CM PLANTERS</b>			
<b>Tractor Hydraulic* and Power Requirements**</b>			
<b>Number of Rows</b>	16	16	16
<b>Meters</b>	True Rate	True Rate	True Rate
<b>Hoppers</b>	Row Hoppers	Bulk Fill	Row Hoppers
<b>Drive</b>	Ground Contact Drive	Ground Contact Drive	Blue Drive
<b>SCV Requirements</b>			
Lift	1	1	1
Rotate/Marker	1	1	1
Bulk Fill (Seed)	-	1	-
Vacuum	1	1	1
Blue Drive / Blue Vantage	-	-	1
Bulk Dry (Fertilizer)	-	-	-
<b>Number of SCV (w/o PTO):</b>	<b>3</b>	<b>4</b>	<b>4</b>
<b>Number of SCV (w/ PTO):</b>	<b>-</b>	<b>2 (Dual Stage PTO)</b>	<b>3 (Single Stage PTO)</b>
Liquid Fertilizer (Diaphragm Pump) (Optional)	-	-	1
<b>Hydraulic Capacity Requirements (l/min)</b>			
Lift & Rotate	57	57	57
Bulk Fill (Seed)	-	38	-
Bulk Dry (Fertilizer)	-	-	-
Vacuum	49	49	49
Blue Drive / Blue Vantage	-	-	38
Active Hydraulic Weight Transfer	-	-	-
True Depth (0.95 Liter/min per Row)	-	-	(optional)
<b>Base configuration<sup>1</sup> total (w/o PTO):</b>	<b>106</b>	<b>144</b>	<b>144</b>
<b>Base configuration<sup>1</sup> total (w/ PTO):</b>	<b>-</b>	<b>57</b>	<b>95</b>
True Depth (0.95 Liter/min per Row)	-	-	15
True Depth (Split Row)	-	-	15
Liquid Fertilizer (Diaphragm Pump)	-	-	15
<b>Estimated minimum flow (w/o PTO):</b>	<b>106</b>	<b>144</b>	<b>189</b>
<b>Estimated minimum flow (w/ PTO):</b>	<b>-</b>	<b>57</b>	<b>140</b>
<b>Tractor Power Requirements (hp)</b>			
Power Requirements	From 240 (16 Row) From 180 (12 Row)	From 240 (16 Row) From 180 (12 Row)	From 240 (16 Row) From 180 (12 Row)
Power Requirements with Split Row	From 340 (16 Row) From 250 (12 Row)	From 340 (16 Row) From 250 (12 Row)	From 340 (16 Row) From 250 (12 Row)

\*All data above is indicative, the table shown above describes the specific hydraulic demands by planter model and functional area. Planter hydraulic requirements depend on a specific planter configuration.

\*\*Soil type, field tillage, terrain, and planter configuration might affect tractor power requirements.

<sup>1</sup>No options of any kind.

<b>KINZE 3605 70CM PLANTERS</b>				
<b>Tractor Hydraulic* and Power Requirements**</b>				
<b>Number of Rows</b>	16	16	16	16
<b>Meters</b>	True Rate	True Rate	True Rate	True Speed
<b>Hoppers</b>	Bulk Fill	Row Hoppers	Row Hoppers	Bulk Fill
<b>Drive</b>	Blue Drive	Ground Contact Drive	Blue Drive	Blue Drive
<b>SCV Requirements</b>				
Lift	1	1	1	1
Rotate/Marker	1	1	1	1
Bulk Fill (Seed)	1	-	-	1
Vacuum	1	1	1	1
Blue Drive / Blue Vantage	1	-	1	1
Bulk Dry (Fertilizer)	-	1	1	-
<b>Number of SCV (w/o PTO):</b>	<b>5</b>	<b>4</b>	<b>5</b>	<b>5</b>
<b>Number of SCV (w/ PTO):</b>	<b>3 (Dual Stage PTO)</b>	<b>3 (Single Stage PTO)</b>	<b>4 (Single Stage PTO)</b>	<b>3 (Dual Stage PTO)</b>
Liquid Fertilizer (Diaphragm Pump) (Optional)	1	-	-	1
<b>Hydraulic Capacity Requirements (l/min)</b>				
Lift & Rotate	57	57	57	57
Bulk Fill (Seed)	38	-	-	38
Bulk Dry (Fertilizer)	-	38	38	-
Vacuum	49	49	49	49
Blue Drive / Blue Vantage	38	-	38	38
Active Hydraulic Weight Transfer	19	-	-	19
True Depth (0.95 Liter/min per Row)	(optional)	-	(optional)	15
<b>Base configuration<sup>1</sup> total (w/o PTO):</b>	<b>201</b>	<b>144</b>	<b>182</b>	<b>216</b>
<b>Base configuration<sup>1</sup> total (w/ PTO):</b>	<b>114</b>	<b>95</b>	<b>132</b>	<b>129</b>
True Depth (0.95 Liter/min per Row)	15	-	15	-
True Depth (Split Row)	15	-	15	15
Liquid Fertilizer (Diaphragm Pump)	15	-	-	15
<b>Estimated minimum flow (w/o PTO):</b>	<b>246</b>	<b>144</b>	<b>212</b>	<b>246</b>
<b>Estimated minimum flow (w/ PTO):</b>	<b>159</b>	<b>95</b>	<b>163</b>	<b>159</b>
<b>Tractor Power Requirements (hp)</b>				
Power Requirements	From 240 (16 Row) From 180 (12 Row)	From 240 (16 Row) From 180 (12 Row)	From 240 (16 Row) From 180 (12 Row)	From 400 (16 Row) From 300 (12 Row)
Power Requirements with Split Row	From 340 (16 Row) From 250 (12 Row)	From 340 (16 Row) From 250 (12 Row)	From 340 (16 Row) From 250 (12 Row)	From 500 (16 Row) From 370 (12 Row)

\*All data above is indicative, the table shown above describes the specific hydraulic demands by planter model and functional area. Planter hydraulic requirements depend on a specific planter configuration.







\*\*Soil type, field tillage, terrain, and planter configuration might affect tractor power requirements.

<sup>1</sup>No options of any kind.

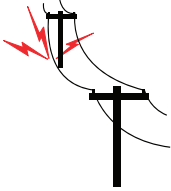
1. Read and understand instructions provided in this manual and warning labels. Review these instructions frequently!
  2. This machine is designed and built with your safety in mind. Do not make any alterations or changes to this machine. Any alteration to design or construction may create safety hazards.
  3. A large portion of farm accidents happen from fatigue or carelessness. Safe and careful operation of tractor and planter will help prevent accidents.
  4. Never allow planter to be operated by anyone unfamiliar with operation of all functions of the unit. Operators must read and thoroughly understand all instructions given in this manual before operating or working on equipment.
  5. Be aware of bystanders, particularly children! Always look around to make sure it is safe to start tow vehicle engine or move planter. This is particularly important with higher noise levels and quiet cabs, as you may not hear people shouting.
  6. Make sure planter weight does not exceed towing capacity of tractor, or bridge and road limits. This is critical to maintain safe control and prevent death or injury, or property and equipment damage.
  7. Never ride or allow others to ride on planter.
  8. Store planter in an area away from human activity. DO NOT permit children to play on or around the stored unit.
  9. Keep hands, feet, and clothing away from moving parts. Do not wear loose-fitting clothing which may catch in moving parts.
  10. Always wear protective clothing, shoes, gloves, hearing, and eye protection applicable for the situation.
  11. Do not allow anyone to stand between tongue or hitch and towing vehicle when backing up to planter.
  13. Prevent electrocution, other injuries, or property and equipment damage. Watch for obstructions such as wires, tree limbs, etc. when operating machine. Be aware of clearances during turns and when folding/unfolding planter.
  14. Reinstall all guards removed for maintenance activities. Never leave guards off during operation.
  15. Use of aftermarket hydraulic, electric, or PTO drives may create serious safety hazards to you and people nearby. If you install such drives, follow all appropriate safety standards and practices to protect you and others near this planter from injury.
  16. Follow all federal, state/provincial, and local regulations when towing farm equipment on a public highway. Use safety chain (not an elastic or nylon/plastic tow strap) to retain connection between towing and towed machines in the event of primary attaching system separation.
  17. Make sure all safety/warning lights, SMV sign, and reflective decals are in place and working properly before transporting the machine on public roads.
  18. Limit towing speed to 24 km/h. Tow only with farm tractor of a minimum 90 HP. Allow for unit length when making turns.
  19. Reduce speed prior to turns to avoid the risk of overturning. Always drive at a safe speed relative to local conditions and ensure your speed is slow enough for a safe emergency stop.
  20. Chemical application is often an integral part of planting. Follow label instructions for proper chemical mixing, handling and container disposal methods.
  21. Be familiar with safety procedures for immediate first aid should you accidentally contact chemical substances.
  22. Use the proper protective clothing and safety equipment when handling chemicals.
  23. Chemicals are supplied with Material Safety Data Sheets (MSDS) that provide full information about the chemical, its effects on exposure, and first aid needs in the event of an emergency. Keep your MSDS file up-to-date and available for first responders in case of emergency.
  24. When servicing ground engaging components such as opening disks and firming points, use special care to avoid points and edges worn sharp during use.
  25. Use professional help if you are unfamiliar with working on hydraulic systems. Pressurized hydraulic fluid can penetrate body tissue and result in death, serious infection, or other injuries.
  26. Transporting planter with hoppers over half full or unevenly loaded can cause loss of control and could result in death, serious injury, or damage to property and equipment.
  27. Disposing of waste improperly can threaten the environment. To dispose of your equipment properly contact your local environmental or recycling center.
- Never pour waste onto the ground, down a drain, or into any water source.
- When disposing of waste such as oil, use leakproof containers. Be sure to use containers that do not resemble food or beverage which may mislead someone into consuming them. Dispose of oil per your local, regional requirements.
- When disposing of any fertilizer chemicals used, contact the supplier of the chemicals.
- Model 3605 planter consists of 85% recyclable metals, 10% recyclable plastic and rubber, and 5% waste.



Following are some common hazard warnings associated with this equipment. Pay close attention to all safety, operating, and maintenance information in this manual and decals applied to your equipment.

 <p><b>DANGER</b></p> 	<p>Contacting or coming close to power lines or other high energy sources will cause death or serious injury.</p> <p>Keep away from power lines or high energy sources at all times.</p>
 <p><b>WARNING</b></p> 	<p>Improperly operating or working on this equipment could result in death or serious injury. Read and follow all instructions in Operator Manual before operating or working on this equipment.</p>
 <p><b>WARNING</b></p> 	<p>Falling equipment can cause death or serious injury. Install all lockup devices or lower planter to ground before working on equipment.</p>
 <p><b>WARNING</b></p> 	<p>Explosive separation of rim and tire parts can cause death or serious injury. Overinflation, rim and tire servicing, improper use of rims and tires, or worn or improperly maintained tires could result in a tire explosion.</p>

**SAFETY SIGNS AND DECALS**

	<p>All safety/warning lights, reflective decals, and SMV sign must be in place and visible before transporting machine on public roads or death, serious injury, and damage to property and equipment may result. Check federal, state/provincial, and local regulations before transporting equipment on public roads.</p>
---	---





Safety signs and decals are placed on the machine to warn of hazards and provide important operating and maintenance instructions. Information on these signs is for your personal safety and the safety of those around you. FOLLOW ALL SAFETY INSTRUCTIONS!

- Keep signs clean so they can be easily seen. Wash with soap and water or cleaning solution as required.
- Replace safety signs if damaged, painted over, or missing.
- Check reflective decals and SMV sign periodically. Replace if they show any loss of reflective properties.
- When replacing decals, clean machine surface thoroughly with soap and water or cleaning solution to remove all dirt and grease.



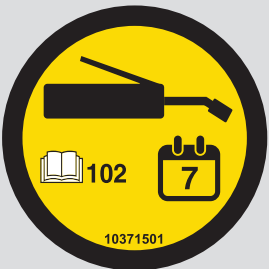

**NOTE:** Safety sign and decal locations are shown in the Parts Manual for this machine.

**NOTE:** Style and locations of SMV sign, reflective decals, and safety/warning lights conform to ANSI/ASABE S279.14 JUL 2008 and ANSI/ASABE S276.6 JAN 2005.

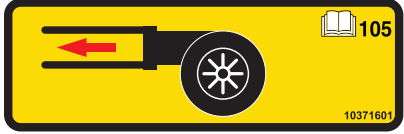
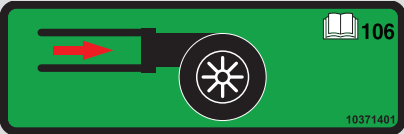
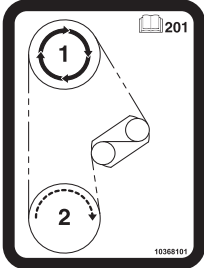

**PICTORIAL DECALS**

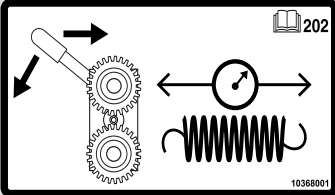
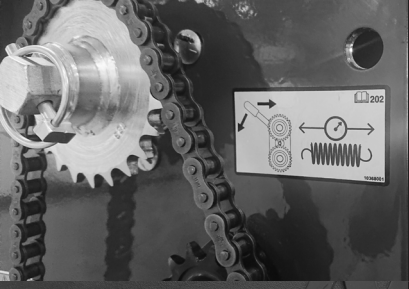
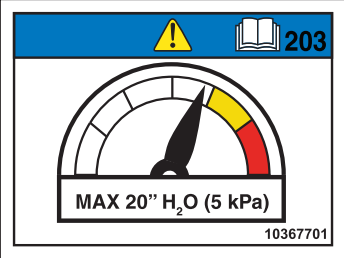
No.	Decal	Placement	Meaning
101			Oil/Grease daily.
102			Oil/Grease weekly.



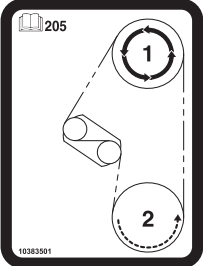
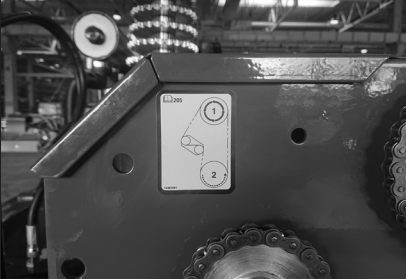

PICTORIAL DECALS

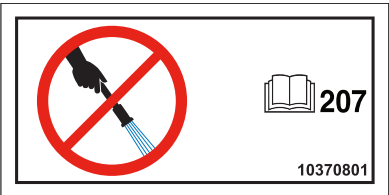
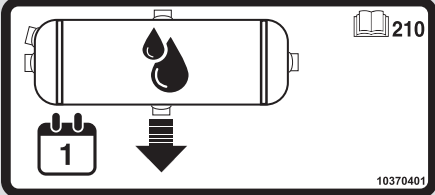
No.	Decal	Placement	Meaning
105		Below Bulk Fill pressure gauge.	Bulk Fill.
106		Below Vacuum gauge.	Vacuum.
201			Upper sprocket is the drive sprocket. Lower sprocket is the driven sprocket.
202			Rotate knurled collar on wrap spring tightener to release spring tension.
203			Maximum operating pressure is 20" H <sub>2</sub> O (5 kPa). Higher pressure can cause seed bridging.



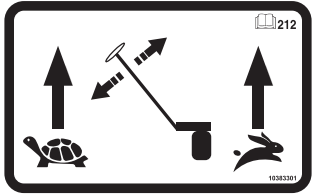
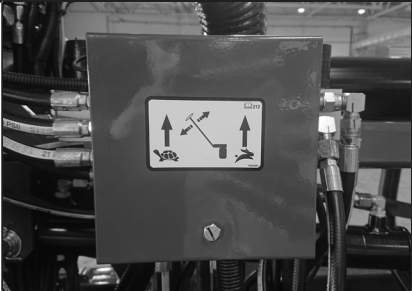
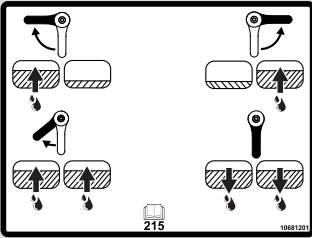





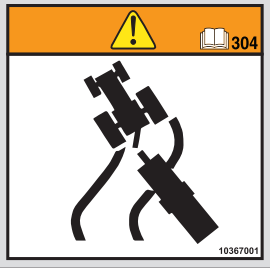

**PICTORIAL DECALS**

No.	Decal	Placement	Meaning
204		On Bulk Fill tank.	Apply a minimum of 16 (0.45 kg) ounces of graphite per 50 units of seed.
205			Upper sprocket is the drive sprocket. Lower sprocket is the driven sprocket.
206		On IPN module.	<p>Ensure that O-Ring(s) are in place on M12 connector(s) (Ethernet).</p> <p>Ensure that M12 connector(s) are torqued to 0.7 Nm.</p>
207		Under PMM module's mount.	DO NOT wash modules directly with cover removed.
210		On PDP tank/valve.	<p>Drain moisture from air tank daily.</p> <p>Drain tank completely for storage.</p>







PICTORIAL DECALS

No.	Decal	Placement	Meaning
212			<p>Control the speed at which row markers raise/lower. Tortoise for slower speed, rabbit for faster speed.</p>
215		<p>On planter frame beside liquid fertilizer tanks (Blue Vantage only)</p>	<p>See "LIQUID FERTILIZER 3-WAY DISTRIBUTION VALVES" on page 4-37</p>
213		<p>On water tank.</p>	<p>Water for emergency rinse.</p>
301		<p>On transport wheel axle.</p>	<p>Overinflation may cause explosive separation of tire and rim, which could result in death or serious injury. Follow inflation specifications and maintenance instructions in the Operator's Manual.</p>
302		<p>On insecticide hopper lids.</p>	<p>Agricultural chemicals can cause death or serious injury to persons, animals, and plants or seriously damage soil, equipment, and property. Read and follow all chemical and equipment manufacturer labels and instructions.</p>





PICTORIAL DECALS

No.	Decal	Placement	Meaning
304			<p>Loss of control can cause death or serious injury, or damage to property and equipment. Tow only with farm tractor weight rated and configured for this equipment. Use safety chains and transport as specified in the Operator's and Parts Manuals.</p>
306			<p>Uncontrolled machine movement can crush resulting in death, serious injury, or damage to property and equipment.</p> <p>Install safety lockup devices before working under or transporting this equipment.</p>
307			<p>Removing this wheel and axle assembly can cause equipment to tip over, which could result in death, serious injury, or damage to property and equipment.</p>
308			<p>Improperly operating or working on this equipment could result in death or serious injury. Read and follow all instructions in Operator Manual before operating or working on this equipment.</p>
309			<p>Row marker can lower at any time and could cause death or serious injury.</p> <p>Stay away from row markers!</p> <p>Install safety lockup device when not in use.</p>

PICTORIAL DECALS

No.	Decal	Placement	Meaning
310			<p>Uncontrolled movement of planter components can cause death, serious injury, or damage to property and equipment.</p> <p>Raise planter and install cylinder lockups before folding. Fold on level ground. Install wing safety latches before towing.</p>
311			<p>Do not remove lid during machine operation. Contents are pressurized and interference could result in death, serious injury or equipment damage.</p> <p>See the Operator's Manual for proper filling procedure.</p>
313		<p>On Catwalk ladder.</p>	<p>Static electricity shock hazard. Static electricity charge may build up during use of planter and discharge when refilling or performing maintenance.</p> <p>Electronic medical devices, such as pacemakers and defibrillators, may malfunction from shock of static electricity discharge.</p> <p>Persons wearing electronic medical devices should use caution to avoid shock when working around planter.</p>
401			<p>Fan can start at any time. Operating fan can blow debris and has a high noise level.</p> <p>Always wear eye and hearing protection when working around fan.</p>

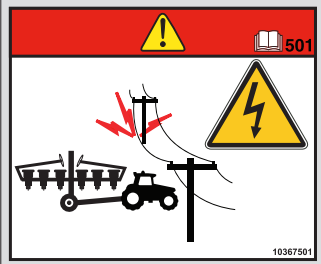
PICTORIAL DECALS

No.	Decal	Placement	Meaning
402			<p>Improper lifting of row unit can cause serious injury. An empty row unit requires minimum 40.8 kg lift. Set down pressure springs to minimum, lower planter to ground, and empty seed hopper before attempting to lift with this lever.</p>
501			<p>Contacting with or coming close to power lines or other high energy sources will cause death or serious injury.</p> <p>Keep away from power lines or high energy sources at all times.</p>
503		<p>On Bulk Fill ladder.</p>	<p>Falling from equipment can cause death or serious injury.</p> <p>Use three points of contact when working on equipment.</p> <p>Never ride on equipment.</p>



### MANUAL SAFETY LOCKUP

 <b>WARNING</b>	<p>Uncontrolled machine movement can crush or cause loss of control resulting in death, serious injury, or damage to property and equipment. Install all safety lockup devices before working under or transporting this equipment.</p>
--	---

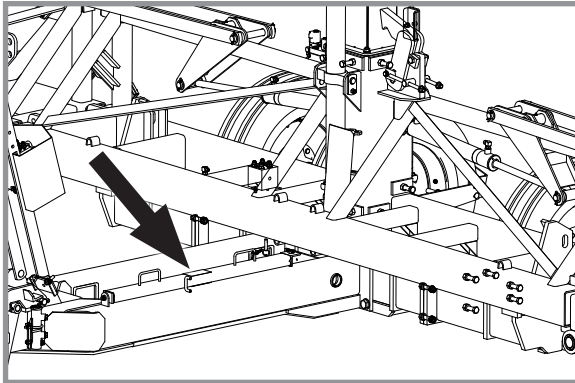

Manual safety lockup in storage position

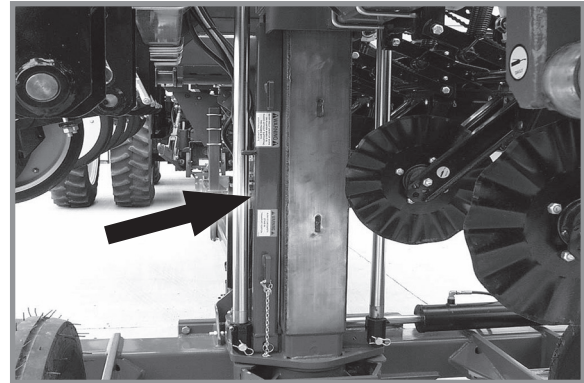

Manual safety lockup in transport position

Remove manual safety lockup and store on L.H. side of hitch for field operation.

### ROW MARKER SAFETY LOCKUP

 <b>WARNING</b>	<p>Row marker can lower at any time and could cause death or serious injury. Stay away from row markers! Install safety lockup device when not in use.</p>

Always install row marker lockups when working or transporting planter.

Connect chain between marker stand and second stage of marker assembly.



Row marker safety lockup installed



Uncontrolled movement of equipment can cause loss of control and could result in death, serious injury, or damage to property and equipment. Install all safety pins before transporting equipment.

**TONGUE SAFETY PIN**

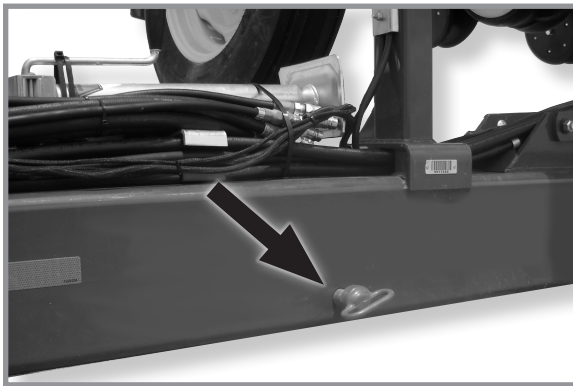

**Tongue safety pin installed for transport**

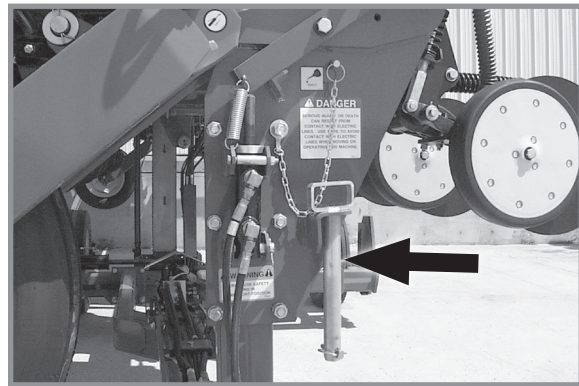

**Tongue safety pin stored for field operation**

Never transport planter without installing tongue safety pin. Tongue safety pin prevents tongue cylinder from retracting should hydraulic failure occur or a sudden stop be made when transporting planter.

Remove tongue safety pin and store in bracket on transport latch post at center of planter for field operation.

**TRANSPORT LATCH LOCKING PIN**

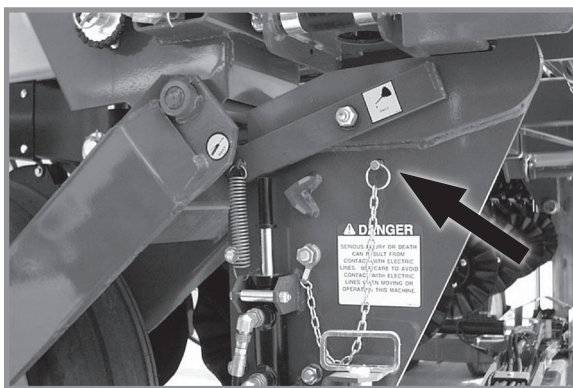

**Transport latch locking pin stored for field operation**

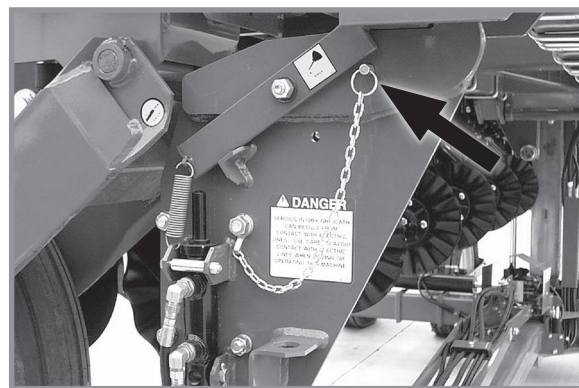

**Transport latch locking pin installed for transport**

Never transport planter without installing transport latch locking pin. Transport latch locking pin prevents latch bar from disengaging and allowing planter frame to swing away.

Remove transport latch locking pin and store in location provided on latch post for field operation.

## INITIAL PREPARATION

Following information is general in nature to aid in preparation of tractor and planter for use, and to provide general operating procedures. Operator experience, familiarity with the machine, and the following information should combine for efficient planter operation and good working habits.

### **WARNING**

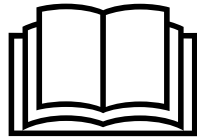

Improperly operating or working on this equipment could result in death or serious injury. Read and follow all instructions in Operator Manual before operating or working on this equipment.

### **WARNING**

Folding or towing planter with outer transport wheel on left side of machine removed can cause death, serious injury, or damage to property and equipment. Tipping may occur because of narrow wheelbase. Outer transport wheel on left side of machine is shipped removed on non-bulk fill planters (not bolted on) to allow narrower width truck shipment. **DO NOT REMOVE THIS ASSEMBLY AFTER PLANTER IS ASSEMBLED FOR USE.**

### **WARNING**



Loose transport wheel lug bolts can result in wheel separation from planter and cause death, serious injury, and damage to property and equipment. Torque transport wheel  $\frac{5}{8}$ " - 18 lug bolts to 270-310 Nm before operating planter for the first time and periodically after.

### **WARNING**

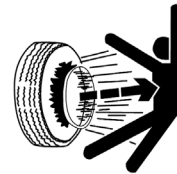

Explosive separation of rim and tire parts can cause death or serious injury. Overinflation, rim and tire servicing, improper use of rims and tires, or worn or improperly maintained tires could result in a tire explosion.

### **WARNING**

Transporting planter with hoppers over half full or unevenly loaded can cause loss of control and could result in death, serious injury, or damage to property and equipment. Properly load planter when transporting. Be aware of extra transport weight, and road conditions and limits.

1. Torque wheel lug nuts to the following specifications:  
 Transport wheel  $\frac{5}{8}$ "- 18 lug nuts to 270 Nm.  
 Ground drive wheel  $\frac{3}{4}$ "- 18 lug nuts to 170 Nm.
2. Inflate tires to the following specifications:  
 Transport (center section) 9" x 22.5" 14PR 110 PSI (758 kPa)  
 Ground drive (wings) 7.50" x 20" 40 PSI (276 kPa)  
 Contact drive 50 PSI (345 kPa).  
 Liquid fertilizer piston pump 7.60" x 15" 40 PSI (276 kPa)

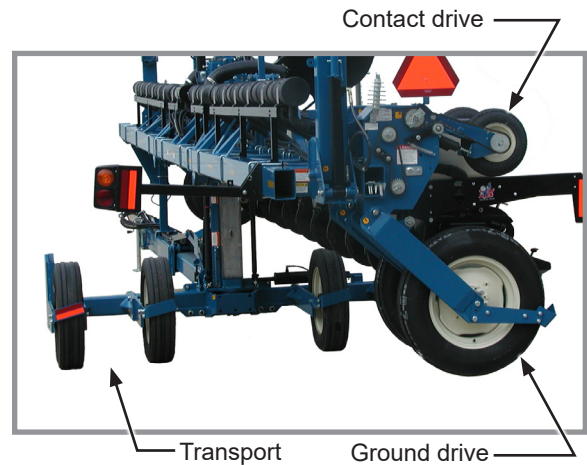

**Tire locations (not all tires shown)**

3. Lubricate planter and row units following instructions in lubrication and Maintenance section of this manual.
4. Check all drive chains for proper tension, alignment, and lubrication.

## TRACTOR REQUIREMENTS

### NOTICE

**All Hydraulic Requirements: Minimum Pressure 2350 PSI (16200 kPa); Maximum Pressure 3000 PSI (20700 kPa). Check tractor hydraulics to ensure that maximum pressure cannot be exceeded.**

Consult your dealer for information on horsepower requirements and tractor compatibility. Requirements vary with planter options, tillage, and terrain.

A 12 VDC electrical system is required on all sizes.

A minimum of two SCV remote hydraulic outlets are required on all sizes. One SCV is used for field lift and with a control console switch operates raise to transport function. A second SCV using control console operates row markers fold/unfold functions. Additional SCV's with a zero pressure case drain are needed for vacuum fan motor for seed metering system, bulk fill, Blue Drive, and Wing Down Pressure (if installed without vacuum or bulk fill).

Maximum hydraulic flow rate of 49 L/min @ 2000 PSI (13800 kPa) is required to operate vacuum fan motor.

## TRACTOR MOUNTED PTO PUMP AND OIL COOLER OPTION

The tractor mounted PTO pump and oil cooler option is for tractors with less than required hydraulic output needed to operate hydraulic-driven vacuum fan and other planter hydraulic requirements.

A 1000 RPM PTO is required to operate the PTO-driven hydraulic pump.

PTO pump option consists of a 1 $\frac{3}{8}$ "-21 or 1 $\frac{1}{2}$ "-20 spline 13.5 GPM 2000 psi tractor mounted pump, planter mounted 10 gallon capacity hydraulic reservoir with spin-on 10-micron oil filter, 15 GPM-rated oil cooler and required hydraulic valves, fittings, and hoses.

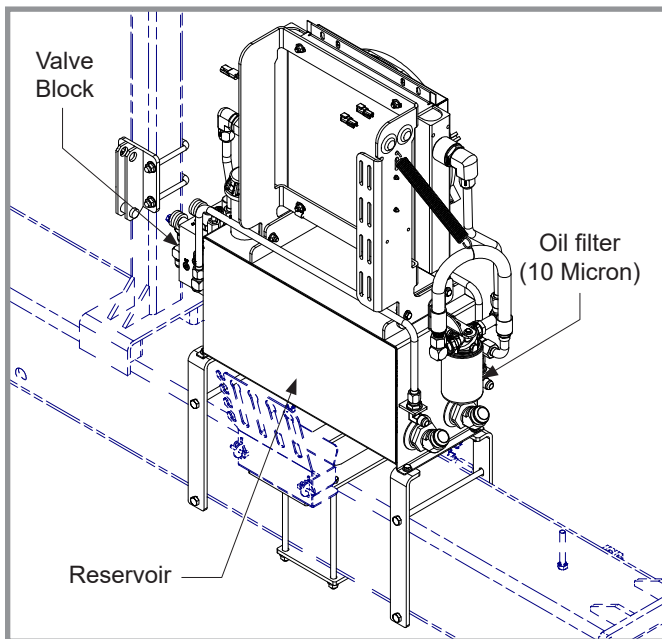

**Dual Stage -- Vacuum/Bulk Fill**

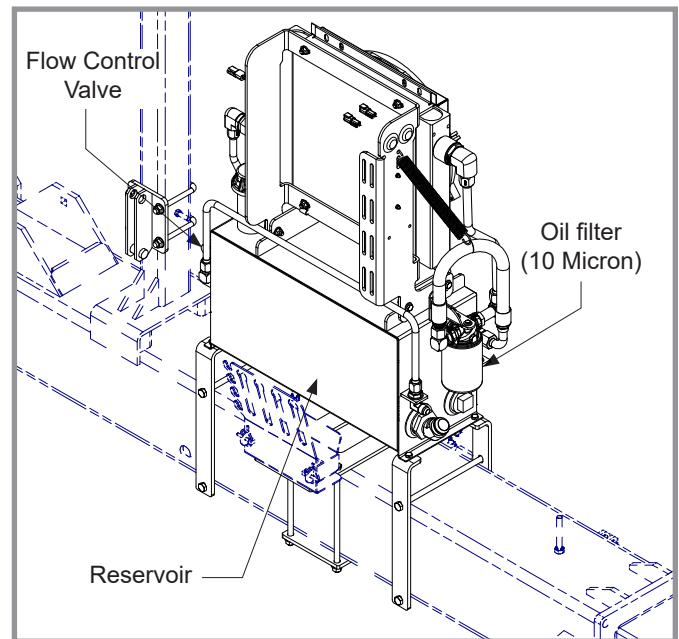

**Single Stage -- Vacuum/Row Hoppers**

## OIL SPECIFICATION

Oil used in the planter and PTO chemical properties:

Viscosity, mm <sup>2</sup> /s @ 100 °C. ASTM D-445	10,0
Viscosity, mm <sup>2</sup> /s @ 40 °C. ASTM D-445	63,0
Viscosity Index ASTM D-2270	143,00
TBN, mg KOH/g ASTM D-2896	9,0
TAN, mg KOH/g (ASTM D-664)	2,0
Pour Point, °C ASTM D-5950	-42,0
Specific Gravity @ 15.6°C. ASTM D-4052	0,876
Flash Point, COC, °C. ASTM D-92	220

**NOTE: Factory filled with VALVOLINE™ UNITRAC SAE 80W.**

## TRACTOR PREPARATION AND HOOKUP

1. Adjust tractor drawbar 33-43 cm above ground with hitch pin hole directly below PTO shaft center line. Make sure drawbar is in a stationary position.
2. Install control console or Kinze Blue Vantage® Display on tractor in a convenient location within easy reach of operator and close to hydraulic controls. Mount control console securely and route power cord to power source. Control console operates on 12 VDC only. If two 12 volt batteries are connected in series, ALWAYS make power connection on battery grounded to tractor chassis.

If two 6 volt batteries are connected in series, make sure power connection provides 12 VDC across positive terminal on one battery and negative terminal of second battery.



Kinze Blue Vantage®

3. Back tractor to planter and connect with 1¼" - 1½" (32 mm - 38 mm) diameter hitch pin. If tractor is not equipped with a hitch pin locking device, make sure hitch pin is secured with a locking pin or cotter pin.

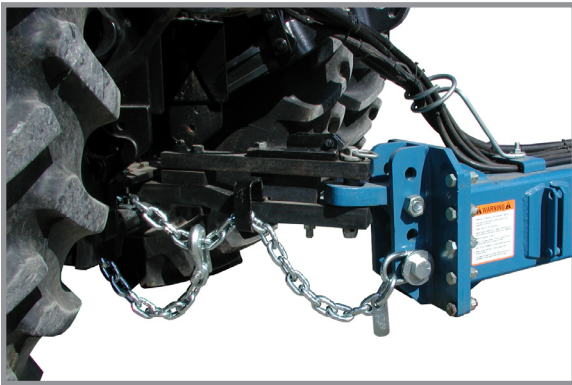

Planter/safety chain hookup to tractor

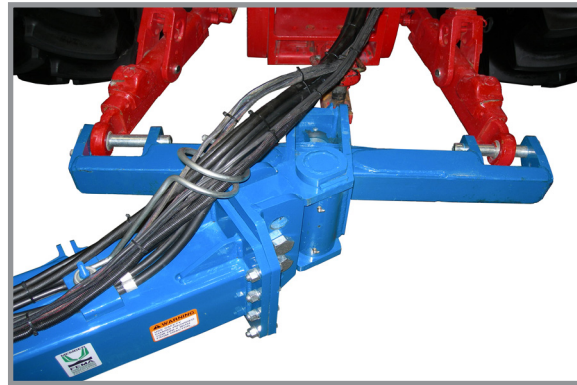



Optional 2-point hitch

**NOTE: DO NOT install safety chain using clevis mounting hardware. Safety chain MUST be installed separately.**

4. Safety chain must be used to keep planter and tractor connected in case of a hitch pin/drawbar failure. Attach safety chain at an unused clevis mounting hole on the planter hitch. Torque hardware to 1140 Nm.

**NOTE: A 2-Point Hitch Option converts planter from drawn to semi-mounted and is available for use with Category 3N or 3 three-point hitch designs. Safety chain is not used with 2-point hitch.**

 <b>WARNING</b>	<p>Pressurized hydraulic fluid can penetrate body tissue and result in death, serious infection, or other injuries. Fluid injected under skin must be <b>IMMEDIATELY</b> removed by a surgeon familiar with this type of injury. Make sure connections are tight and hoses and fittings are not damaged before applying system pressure. Leaks can be invisible. Keep away from suspected leaks. Relieve pressure before searching for leaks or performing any system maintenance.</p>
	

<b>NOTICE</b>	<p>Wipe hose ends to remove any dirt before connecting couplers to tractor parts or contamination may cause equipment failure.</p>
---------------	--

5. Connect hydraulic hoses to tractor ports in a sequence familiar and comfortable to the operator.
6. (If applicable) Install PTO pump onto tractor PTO shaft. Make sure shaft rotation matches direction indicated on pump housing.
7. (If applicable) Connect compressor harness.
8. If equipped with True Depth<sup>®</sup>, attach the True Depth 6 pin connector.
9. If equipped with Blue Drive<sup>®</sup>, attach the Blue Drive<sup>®</sup> 6 pin connector and Ethernet cable to the Blue Vantage<sup>®</sup> display.

<b>NOTICE</b>	<p>Connect hydraulic motor case drain to a case drain return line with zero PSI on tractor. Failure to connect to a return with zero PSI will cause hydraulic motor shaft seal damage. <b>DO NOT</b> connect hydraulic motor case drain to a SCV outlet or motor return circuit connection. Contact tractor manufacturer for specific details on “zero pressure return”.</p>
---------------	--

<b>NOTICE</b>	<p>Always connect hydraulic motor return hose to tractor motor return port. Do not connect to tractor SCV unless through a motor spool or hydraulic motor failure can occur. If a motor return port is not available on the tractor, the SCV controlling the bulk fill system <b>MUST</b> be in the float position before planter is moved in planting or field raised position when bulk fill system is not in use.</p>
---------------	--

PLANTER TO TRACTOR HYDRAULIC CONNECTIONS			
Color/Label	Machine Function	Hose Size	Function
Red	Field Lift	1/2"	Pressure
Red		1/2"	Return
Blue	Planter Fold & Row Marker	3/8"	Return
Blue		3/8"	Pressure
Black	Power Pack (Blue Drive)	1/2"	Return
Black		3/8"	Pressure
Green	Vacuum Fan	3/4"	Return
Green		1/2"	Pressure
Orange		3/8"	Case Drain
Yellow	Bulk Fill System Pressure Fan	3/4"	Motor Return
Yellow		1/2"	Pressure
Orange		3/8"	Case Drain

PART NO.	LETTER	COLOR	SYMBOL
A26924-01	EXTEND	RED	←
A26924-02	RETRACT	RED	→
A26924-03	EXTEND	BLUE	←
A26924-04	RETRACT	BLUE	→
A26924-05	EXTEND	GREEN	←
A26924-06	RETRACT	GREEN	→
A26924-07	EXTEND	YELLOW	←
A26924-08	RETRACT	YELLOW	→
A26924-09	EXTEND	BLACK	←
A26924-10	RETRACT	BLACK	→
A26924-11	RETRACT	ORANGE	→
A26924-12	EXTEND	LT BROWN	←
A26924-13	RETRACT	LT BROWN	→

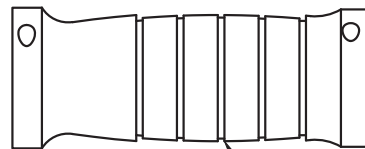

SEE CHART FOR COLOR, SYMBOL, AND PART NUMBER

**NOTE:** Set adjustable flow outlet (SCV) to full flow position.

For tractors not equipped with a method for finite adjustment of hydraulic flow, Flow Control Needle Valve Kit G1K426 is available from Kinze Repair Parts through your Kinze Dealer.

**NOTE:** Not to be used in Blue Drive® applications.



G1K426 needle valve kit



10. Connect ASABE Standards 7 terminal connector for safety/warning lights on planter to ASABE Standards receptacle on tractor. If your tractor is not equipped with an ASABE Standards receptacle, check with your tractor manufacturer for availability. Check warning lights on planter work in conjunction with warning lights on tractor.

**NOTE: A 12 volt battery connection is required to power the vacuum fan digital gauge. Connect “red” wire to positive (+) battery terminal and “black” wire to negative (-) battery terminal.**

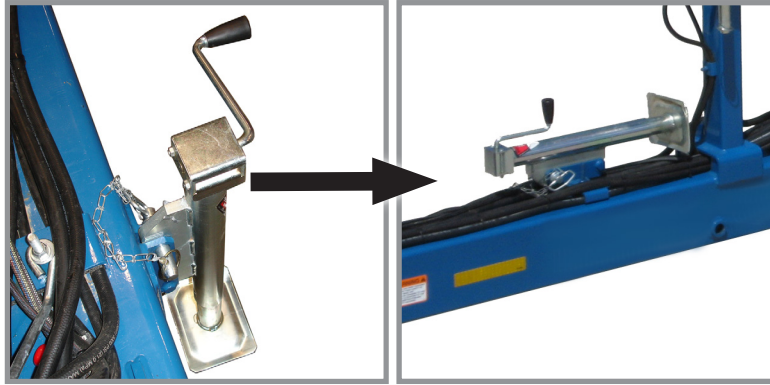

**Remove and store jack**

11. Raise jack stand and remount horizontally on storage bracket.

**CYLINDER INFORMATION**

	Wing Down Pressure Cylinder	Row Marker Cylinder	Rotation Cylinder	Tongue Cylinder	Wing Lift Cylinder
<b>Intended Use</b>	Double acting applications	Double acting applications	Double acting applications	Double acting applications	Double acting applications
<b>Piston</b>	Ductile iron	Ductile iron	Ductile iron	Ductile iron	Ductile iron
<b>Gland</b>	Ductile iron	Ductile iron	Ductile iron	Ductile iron	Ductile iron
<b>Tube</b>	ST 52 Dom	ST 52 Dom	ST 52 Dom	ST 52 Dom	ST 52 Dom
<b>Rod</b>	1045 Nitro rod	1045 Nitro rod	1045 Nitro rod	1045 Nitro rod	1045 Nitro rod
<b>End Mounts</b>	U-bracket	Sleeve	Tang	None	Gimble
<b>Tube Seal</b>	O-ring with polytemp back-up	Buna O-Ring with polytemp back-up	Buna O-Ring with polytemp back-up	O-ring with polytemp back-up	Buna O-Ring with polytemp back-up
<b>Rod Seal</b>	Polyester alloy u-cup	Polyester alloy u-cup	Polyester alloy u-cup	Polyester alloy u-cup	Polyester alloy u-cup
<b>Rod Wiper</b>	Polyester alloy snap in	Polyester alloy snap in	Polyester alloy snap in	Polyester alloy snap in	Polyester alloy snap in
<b>Piston Seal</b>	T-seal hnbr	T-seal hnbr	PTFE	T-seal hnbr	PTFE
<b>Specifications</b>					
<b>Product Category</b>	Hydraulic Cylinder	Hydraulic Cylinder	Hydraulic Cylinder	Hydraulic Cylinder	Hydraulic Cylinder
<b>Maximum Stroke</b>	8" (203 mm)	20.62" (524 mm)	16" (406 mm)	73" (1854 mm)	6" (152 mm)
<b>Working Pressure</b>	3000 PSI (20700 kPa)	3000 PSI (20700 kPa)	3000 PSI (20700 kPa)	3000 PSI (20700 kPa)	3000 PSI (20700 kPa)
<b>Bore Size</b>	3" (76 mm)	2" (51 mm)	4" (102 mm)	3" (76 mm)	4" (102 mm)
<b>Shaft Diameter</b>	1.25" (32 mm)	1.25" (32 mm)	1.50" (38 mm)	1.75" (44 mm)	1.50" (38 mm)
<b>Cylinder Configuration</b>	Simple	Simple	Simple	Simple	Simple
<b>Cylinder Action</b>	Double	Double	Double	Double	Double
<b>Material</b>	Steel, Ductile Iron	Steel, Ductile Iron	Steel, Ductile Iron	Steel, Ductile Iron	Steel, Ductile Iron
<b>Mounting Method</b>	U-Bracket	Sleeve	Tang	None	Gimble
<b>Mount Location</b>	End Cap	End Cap	End Cap	End Cap	Side's of Barrel

**CYLINDER INFORMATION (Continued)**

	Center Lift Cylinder	Wing Lock Cylinder	Transport Latch Cylinder	Tongue Lock Cylinder	
<b>Intended Use</b>	Double acting applications	Double acting applications	Double acting applications	Double acting applications	
<b>Piston</b>	Ductile iron	Ductile iron	Ductile iron	Ductile iron	
<b>Gland</b>	Ductile iron	Ductile iron	Ductile iron	Ductile iron	
<b>Tube</b>	ST 52 Dom	ST 52 Dom	Cast	Cast	
<b>Rod</b>	1045 Nitro rod	1045 Nitro rod	1045 Nitro rod	1045 Nitro rod	
<b>End Mounts</b>	Gimble	Sleeve	None	None	
<b>Tube Seal</b>	Buna O-Ring with polytemp back-up	O-Ring with polytemp back-up	O-Ring with polytemp back-up	O-Ring with polytemp back-up	
<b>Rod Seal</b>	Polyester alloy u-cup	Polyester alloy u-cup	Polyester alloy u-cup	Polyester alloy u-cup	
<b>Rod Wiper</b>	Polyester alloy snap in	Polyester alloy snap in	Polyester alloy snap in	Polyester alloy snap in	
<b>Piston Seal</b>	PTFE	T-Seal HNBR	T-Seal HNBR	T-Seal HNBR	
<b>Specifications</b>					
<b>Product Category</b>	Hydraulic Cylinder	Hydraulic Cylinder	Hydraulic Cylinder	Hydraulic Cylinder	
<b>Maximum Stroke</b>	48" (1219 mm)	20.062" (510 mm)	2.5" (64 mm)	2.5" (64 mm)	
<b>Working Pressure</b>	3000 PSI (20700 kPa)	3000 PSI (20700 kPa)	3000 PSI (20700 kPa)	3000 PSI (20700 kPa)	
<b>Bore Size</b>	3.25" (83 mm)	2.5" (64 mm)	1.5" (38 mm)	1.5" (38 mm)	
<b>Shaft Diameter</b>	2" (51 mm)	1.5" (38 mm)	.750" (19 mm)	.750" (19 mm)	
<b>Cylinder Configuration</b>	Simple	Simple	Simple	Simple	
<b>Cylinder Action</b>	Double	Double	Double	Double	
<b>Material</b>	Steel, Ductile Iron	Steel, Ductile Iron	Steel, Ductile Iron, Cast	Steel, Ductile Iron, Cast	
<b>Mounting Method</b>	Gimble	Sleeve	None	None	
<b>Mount Location</b>	Side's of Barrel	End Cap	End Cap	End Cap	
<b>Cylinder Style</b>	Welded	Welded	Machined	Machined	

**HYDRAULIC HOSE INFORMATION**

Part Number	A1018	A1076	A1110	A1139	A12090	A1424
<b>Description</b>	Hose Assembly 3/8" x 1.02 m (40") (08F - 08F)	Hose Assembly 3/8" x 3.30 m (130") (08F - 08F)	Hose Assembly 1/4" x 3.81 m (150") (06F - 06F)	Hose Assembly 1/4" x 1.02 m (40") (06F - 06F)	Hose Assembly 3/8" x 1.60 m (63") (08F - 08F)	Hose Assembly 1/2" x 0.76 m (30") (10F - 10F)
<b>Product Category</b>	Hydraulic Hose	Hydraulic Hose	Hydraulic Hose	Hydraulic Hose	Hydraulic Hose	Hydraulic Hose
<b>Product Form</b>	Hose; Assembly	Hose; Assembly	Hose; Assembly	Hose; Assembly	Hose; Assembly	Hose; Assembly
<b>I.D.</b>	3/8" (9.5 mm)	3/8" (9.5 mm)	1/4" (6.4 mm)	1/4" (6.4 mm)	3/8" (9.5 mm)	1/2" (12.7 mm)
<b>O.D.</b>	11/16" (17.5 mm)	11/16" (17.5 mm)	17/32" (13.5 mm)	17/32" (13.5 mm)	11/16" (17.5 mm)	13/16" (20.3 mm)
<b>Minimum Bend Radius</b>	2.5" (64 mm)	2.5" (64 mm)	2" (51 mm)	4" (102 mm)	2.5" (64 mm)	3.5" (89 mm)
<b>Working Pressure</b>	3000 PSI (20700 kPa)	3000 PSI (20700 kPa)	3250 PSI (22400 kPa)	3275 PSI (22600 kPa)	3000 PSI (20700 kPa)	3000 PSI (20700 kPa)
<b>Temperature Range</b>	-40°C - +100°C	-40°C - +100°C	-40°C - +100°C	-40°C - +100°C	-40°C - +100°C	-40°C - +100°C
<b>Material</b>	Modified Nitrile Type C2	Modified Nitrile Type C2	Modified Nitrile Type C2	Modified Nitrile Type C2	Modified Nitrile Type C2	Modified Nitrile Type C2
<b>Specialized Construction</b>	Single Wire Braid	Single Wire Braid	Single Wire Braid	Single Wire Braid	Single Wire Braid	Single Wire Braid
<b>Media</b>	Hydraulic Fluid	Hydraulic Fluid	Hydraulic Fluid	Hydraulic Fluid	Hydraulic Fluid	Hydraulic Fluid
<b>Application</b>	Agricultural and Construction	Agricultural and Construction	Agricultural and Construction	Agricultural and Construction	Agricultural and Construction	Agricultural and Construction

Part Number	A1478	A3111	A3131	A3158	A1034	A1053
<b>Description</b>	Hose Assembly 1/2" x 3.25 m (128") (10F - 10F)	Hose Assembly 3/8" x 5.08 m (200") (08F - 08F)	Hose Assembly 3/8" x 1.07 m (42") (08F - 08F)	Hose Assembly 3/8" x 1.17 m (46") (08F - 08F)	Hose Assembly 3/8" x 6.91 m (272") (08F - 08F)	Hose Assembly 3/8" x 1.83 m (72") (08F - 08F)
<b>Product Category</b>	Hydraulic Hose	Hydraulic Hose	Hydraulic Hose	Hydraulic Hose	Hydraulic Hose	Hydraulic Hose
<b>Product Form</b>	Hose; Assembly	Hose; Assembly	Hose; Assembly	Hose; Assembly	Hose; Assembly	Hose; Assembly
<b>I.D.</b>	1/2" (12.7 mm)	3/8" (9.5 mm)	3/8" (9.5 mm)	3/8" (9.5 mm)	3/8" (9.5 mm)	3/8" (9.5 mm)
<b>O.D.</b>	13/16" (20.6 mm)	11/16" (17.5 mm)	11/16" (17.5 mm)	11/16" (17.5 mm)	11/16" (17.5 mm)	11/16" (17.5 mm)
<b>Minimum Bend Radius</b>	3.5" (89 mm)	2.5" (64 mm)	2.5" (64 mm)	2.5" (64 mm)	2.5" (64 mm)	2.5" (64 mm)
<b>Working Pressure</b>	3000 PSI (20700 kPa)	3000 PSI (20700 kPa)	3000 PSI (20700 kPa)	3000 PSI (20700 kPa)	3000 PSI (20700 kPa)	3000 PSI (20700 kPa)
<b>Temperature Range</b>	-40°C - +100°C	-40°C - +100°C	-40°C - +100°C	-40°C - +100°C	-40°C - +100°C	-40°C - +100°C
<b>Material</b>	Modified Nitrile Type C2	Modified Nitrile Type C2	Modified Nitrile Type C2	Modified Nitrile Type C2	Modified Nitrile Type C2	Modified Nitrile Type C2
<b>Specialized Construction</b>	Single Wire Braid	Single Wire Braid	Single Wire Braid	Single Wire Braid	Single Wire Braid	Single Wire Braid
<b>Media</b>	Hydraulic Fluid	Hydraulic Fluid	Hydraulic Fluid	Hydraulic Fluid	Hydraulic Fluid	Hydraulic Fluid
<b>Application</b>	Agricultural; Construction	Agricultural; Construction	Agricultural; Construction	Agricultural; Construction	Agricultural; Construction	Agricultural; Construction

## HYDRAULIC HOSE INFORMATION (Continued)

Part Number	A1116	A12042	A1404	A11443	A11442	A3122
<b>Description</b>	Hose Assembly 1/4" x 3.45 m (136") (06F - 06F)	Hose Assembly 3/8" x 5.79 m (228") (08F - 08F)	Hose Assembly, 1/2" x 1.04 m (41") (10F - 10F)	Hose Assembly, 5/8" x ~185 cm (73") (12F - 12F)	Hose Assembly, 5/8" x ~349 cm (137.5") (12F - 12F)	Hose Assembly, 3/8" x 0.27 m (10 1/2") (08F - 08F)
<b>Product Category</b>	Hydraulic Hose	Hydraulic Hose	Hydraulic Hose	Hydraulic Hose	Hydraulic Hose	Hydraulic Hose
<b>Product Form</b>	Hose; Assembly	Hose; Assembly	Hose; Assembly	Hose; Assembly	Hose; Assembly	Hose; Assembly
<b>I.D.</b>	1/4" (6.0 mm)	3/8" (9.5 mm)	1/2" (13.0 mm)	5/8" (~15,88 mm)	5/8" (~15,88 mm)	3/8" (9.5 mm)
<b>O.D.</b>	17/32" (13.5 mm)	11/16" (17.5 mm)	13/16" (20.6 mm)	15/16" (~23,81 mm)	15/16" (~23,81 mm)	11/16" (17.5 mm)
<b>Minimum Bend Radius</b>	4" (102 mm)	2.5" (64 mm)	3.5" (89 mm)	4" (~101,60 mm)	4" (~101,60 mm)	2.5" (64 mm)
<b>Working Pressure</b>	3275 PSI (22600 kPa)	3000 PSI (20700 kPa)	3000 PSI (20700 kPa)	2750 PSI (~18961 kPa)	2750 PSI (~18961 kPa)	3000 PSI (20700 kPa)
<b>Temperature Range</b>	-40°C - +100°C	-40°C - +100°C	-40°C - +100°C	-40°C - +100°C	-40°C - +100°C	-40°C - +100°C
<b>Material</b>	Modified Nitrile Type C2	Modified Nitrile Type C2	Modified Nitrile Type C2	Modified Nitrile Type C2	Modified Nitrile Type C2	Modified Nitrile Type C2
<b>Specialized Construction</b>	Single Wire Braid	Single Wire Braid	Single Wire Braid	High tensile steel wire	High tensile steel wire	Single Wire Braid
<b>Media</b>	Hydraulic Fluid	Hydraulic Fluid	Hydraulic Fluid	Hydraulic Fluid	Hydraulic Fluid	Hydraulic Fluid
<b>Application</b>	Agricultural; Construction	Agricultural; Construction	Agricultural; Construction	Agricultural; Construction	Agricultural; Construction	Agricultural; Construction

Part Number	A3139	A8267	A1055	A11449	A11450	A12754
<b>Description</b>	Hose Assembly, 3/8" x 6.45 m (254") (08F - 08F)	Hose Assembly, 1/2" x 1.47 m (58") (10F - 10F)	Hose Assembly, 3/8" x 1.68 m (66") (08F - 08F)	Hose Assembly, 5/8" x ~523 cm (206") (1/2M NPTF - 12F)	Hose Assembly, 5/8" x ~676 cm (266") (1/2M NPTF - 12F)	Hose Assembly 1/2" x ~523 cm (206") (1/2M NPTF - 10F)
<b>Product Category</b>	Hydraulic Hose	Hydraulic Hose	Hydraulic Hose	Hydraulic Hose	Hydraulic Hose	Hydraulic Hose
<b>Product Form</b>	Hose; Assembly	Hose; Assembly	Hose; Assembly	Hose; Assembly	Hose; Assembly	Hose; Assembly
<b>I.D.</b>	3/8" (9.5 mm)	1/2" (13.0 mm)	3/8" (9.5 mm)	5/8" (~15,88 mm)	5/8" (~15,88 mm)	1/2" (12.7 mm)
<b>O.D.</b>	11/16" (17.5 mm)	13/16" (20.6 mm)	11/16" (17.5 mm)	15/16" (~23,81 mm)	15/16" (~23,81 mm)	13/16" (20.6 mm)
<b>Minimum Bend Radius</b>	2.5" (64 mm)	3.5" (89 mm)	2.5" (64 mm)	4" (~101,60 mm)	4" (~101,60 mm)	3.5" (89 mm)
<b>Working Pressure</b>	3000 PSI (20700 kPa)	3000 PSI (20700 kPa)	3000 PSI (20700 kPa)	2750 PSI (~18961 kPa)	2750 PSI (~18961 kPa)	3000 PSI (20700 kPa)
<b>Temperature Range</b>	-40°C - +100°C	-40°C - +100°C	-40°C - +100°C	-40°C - +100°C	-40°C - +100°C	-40°C - +100°C
<b>Material</b>	Modified Nitrile Type C2	Modified Nitrile Type C2	Modified Nitrile Type C2	Modified Nitrile Type C2	Modified Nitrile Type C2	Modified Nitrile Type C2
<b>Specialized Construction</b>	Single Wire Braid	Single Wire Braid	High tensile steel wire	High tensile steel wire	High tensile steel wire	Single Wire Braid
<b>Media</b>	Hydraulic Fluid	Hydraulic Fluid	Hydraulic Fluid	Hydraulic Fluid	Hydraulic Fluid	Hydraulic Fluid
<b>Application</b>	Agricultural; Construction	Agricultural; Construction	Agricultural; Construction	Agricultural; Construction	Agricultural; Construction	Agricultural; Construction

**HYDRAULIC HOSE INFORMATION (Continued)**

Part Number	A8266	A12751	A1464	A3117	A12076	A12085
<b>Description</b>	Hose Assembly ½" x ~681 cm (268") (10F - 10F)	Hose Assembly ½" x ~362 cm (142.5") (10F - 10F)	Hose Assembly ½" x ~183 cm (72") (10F - 10F)	Hose Assembly ¾" x ~447 cm (176") (08F - 08F)	Hose Assembly ¾" x ~419 cm (165") (08F - 08F)	Hose Assembly ¾" x ~66 cm (26") (08F - 10F)
<b>Product Category</b>	Hydraulic Hose	Hydraulic Hose	Hydraulic Hose	Hydraulic Hose	Hydraulic Hose	Hydraulic Hose
<b>Product Form</b>	Hose; Assembly	Hose; Assembly	Hose; Assembly	Hose; Assembly	Hose; Assembly	Hose; Assembly
<b>I.D.</b>	½" (12.7 mm)	½" (12.7 mm)	½" (12.7 mm)	¾" (9.5 mm)	¾" (9.5 mm)	¾" (9.5 mm)
<b>O.D.</b>	¹³/₁₆" (20.6 mm)	¹³/₁₆" (20.6 mm)	¹³/₁₆" (20.6 mm)	¹¹/₁₆" (17.5 mm)	¹¹/₁₆" (17.5 mm)	¹¹/₁₆" (17.5 mm)
<b>Minimum Bend Radius</b>	3.5" (89 mm)	3.5" (89 mm)	3.5" (89 mm)	2.5" (64 mm)	2.5" (64 mm)	2.5" (64 mm)
<b>Working Pressure</b>	3000 PSI (20700 kPa)	3000 PSI (20700 kPa)	3000 PSI (20700 kPa)	3000 PSI (20700 kPa)	3000 PSI (20700 kPa)	3000 PSI (20700 kPa)
<b>Temperature Range</b>	-40°C - +100°C	-40°C - +100°C	-40°C - +100°C	-40°C - +100°C	-40°C - +100°C	-40°C - +100°C
<b>Material</b>	Modified Nitrile Type C2	Modified Nitrile Type C2	Modified Nitrile Type C2	Modified Nitrile Type C2	Modified Nitrile Type C2	Modified Nitrile Type C2
<b>Specialized Construction</b>	Single Wire Braid	Single Wire Braid	Single Wire Braid	Single Wire Braid	Single Wire Braid	Single Wire Braid
<b>Media</b>	Hydraulic Fluid	Hydraulic Fluid	Hydraulic Fluid	Hydraulic Fluid	Hydraulic Fluid	Hydraulic Fluid
<b>Application</b>	Agricultural; Construction	Agricultural; Construction	Agricultural; Construction	Agricultural; Construction	Agricultural; Construction	Agricultural; Construction

Part Number	A12752	A1021	A18693-	A12747	A18667-	A21548-
<b>Description</b>	Hose Assembly ½" x ~58.5 cm (23") (10F - 12F)	Hose Assembly ¾" x ~142 cm (56") (08F - 08F)	Hose Assembly ½" x - cm (-") (10F - 1/2M NPTF)	Hose Assembly ½" x ~498 cm (196") (08F - 10F)	Hose Assembly ½" x - cm (-") (08F - 08F)	Hose Assembly, ¾" x - cm (-) (12F - 1/2M NPTF)
<b>Product Category</b>	Hydraulic Hose	Hydraulic Hose	Hydraulic Hose	Hydraulic Hose	Hydraulic Hose	Hydraulic Hose
<b>Product Form</b>	Hose; Assembly	Hose; Assembly	Hose; Assembly	Hose; Assembly	Hose; Assembly	Hose; Assembly
<b>I.D.</b>	½" (12.7 mm)	¾" (9.5 mm)	½" (12.7 mm)	½" (12.7 mm)	½" (12.7 mm)	⁵/₈" (~15,88 mm)
<b>O.D.</b>	¹³/₁₆" (20.6 mm)	¹¹/₁₆" (17.5 mm)	¹³/₁₆" (20.6 mm)	¹³/₁₆" (20.6 mm)	¹³/₁₆" (20.6 mm)	¹⁵/₁₆" (~23,81 mm)
<b>Minimum Bend Radius</b>	3.5" (89 mm)	2.5" (64 mm)	3.5" (89 mm)	3.5" (89 mm)	3.5" (89 mm)	4" (~101,60 mm)
<b>Working Pressure</b>	3000 PSI (20700 kPa)	3000 PSI (20700 kPa)	3000 PSI (20700 kPa)	3000 PSI (20700 kPa)	3000 PSI (20700 kPa)	2750 PSI (~18961 kPa)
<b>Temperature Range</b>	-40°C - +100°C	-40°C - +100°C	-40°C - +100°C	-40°C - +100°C	-40°C - +100°C	-40°C - +100°C
<b>Material</b>	Modified Nitrile Type C2	Modified Nitrile Type C2	Modified Nitrile Type C2	Modified Nitrile Type C2	Modified Nitrile Type C2	Modified Nitrile Type C2
<b>Specialized Construction</b>	Single Wire Braid	Single Wire Braid	Single Wire Braid	Single Wire Braid	Single Wire Braid	High tensile steel wire
<b>Media</b>	Hydraulic Fluid	Hydraulic Fluid	Hydraulic Fluid	Hydraulic Fluid	Hydraulic Fluid	Hydraulic Fluid
<b>Application</b>	Agricultural; Construction	Agricultural; Construction	Agricultural; Construction	Agricultural; Construction	Agricultural; Construction	Agricultural; Construction

## HYDRAULIC HOSE INFORMATION (Continued)

Part Number	A25487	A11440	A21530-	A12097	A15081-	A7678-
<b>Description</b>	Hose Assembly, 5/8" x - cm (-) (10F - 12F)	Hose Assembly, 5/8" x ~620 cm (244") (10F - 10F)	Hose Assembly, 5/8" x - cm (-) (10F - 10F)	Hose Assembly 3/8" x ~625 cm (246") (06F - 06F)	Hose Assembly 3/8" x - cm (-) (06F - 06F)	Hose Assembly 1/4" x -cm (-) (04F - 04F)
<b>Product Category</b>	Hydraulic Hose	Hydraulic Hose	Hydraulic Hose	Hydraulic Hose	Hydraulic Hose	Hydraulic Hose
<b>Product Form</b>	Hose; Assembly	Hose; Assembly	Hose; Assembly	Hose; Assembly	Hose; Assembly	Hose; Assembly
<b>I.D.</b>	5/8" (~15,88 mm)	5/8" (~15,88 mm)	5/8" (~15,88 mm)	3/8" (9.5 mm)	3/8" (9.5 mm)	1/4" (6.4 mm)
<b>O.D.</b>	15/16" (~23,81 mm)	15/16" (~23,81 mm)	15/16" (~23,81 mm)	11/16" (17.5 mm)	11/16" (17.5 mm)	17/32" (13.5 mm)
<b>Minimum Bend Radius</b>	4" (~101,60 mm)	4" (~101,60 mm)	4" (~101,60 mm)	2.5" (64 mm)	2.5" (64 mm)	2" (51 mm)
<b>Working Pressure</b>	2750 PSI (~18961 kPa)	2750 PSI (~18961 kPa)	2750 PSI (~18961 kPa)	3000 PSI (20700 kPa)	3000 PSI (20700 kPa)	3250 PSI (22400 kPa)
<b>Temperature Range</b>	-40°C - +100°C	-40°C - +100°C	-40°C - +100°C	-40°C - +100°C	-40°C - +100°C	-40°C - +100°C
<b>Material</b>	Modified Nitrile Type C2	Modified Nitrile Type C2	Modified Nitrile Type C2	Modified Nitrile Type C2	Modified Nitrile Type C2	Modified Nitrile Type C2
<b>Specialized Construction</b>	High tensile steel wire	High tensile steel wire	High tensile steel wire	Single Wire Braid	Single Wire Braid	Single Wire Braid
<b>Media</b>	Hydraulic Fluid	Hydraulic Fluid	Hydraulic Fluid	Hydraulic Fluid	Hydraulic Fluid	Hydraulic Fluid
<b>Application</b>	Agricultural; Construction	Agricultural; Construction	Agricultural; Construction	Agricultural; Construction	Agricultural; Construction	Agricultural and Construction

Part Number	A7677-	A25504-	A7680-	A12038	A12095	A12755
<b>Description</b>	Hose Assembly 1/4" x -cm (-) (04F - 04FSTD90)	Hose Assembly 3/8" x - cm (-) (08FS90 - 06F)	Hose Assembly 1/4" x -cm (-) (04F - 06F)	Hose Assembly 3/8" x ~76 cm (30") (06F - 06F)	Hose Assembly 3/8" x ~203 cm (80") (06F - 06F)	Hose Assembly 1/2" x ~112 cm (44") (10F - 10F)
<b>Product Category</b>	Hydraulic Hose	Hydraulic Hose	Hydraulic Hose	Hydraulic Hose	Hydraulic Hose	Hydraulic Hose
<b>Product Form</b>	Hose; Assembly	Hose; Assembly	Hose; Assembly	Hose; Assembly	Hose; Assembly	Hose; Assembly
<b>I.D.</b>	1/4" (6.4 mm)	3/8" (9.5 mm)	1/4" (6.4 mm)	3/8" (9.5 mm)	3/8" (9.5 mm)	1/2" (12.7 mm)
<b>O.D.</b>	17/32" (13.5 mm)	11/16" (17.5 mm)	17/32" (13.5 mm)	11/16" (17.5 mm)	11/16" (17.5 mm)	13/16" (20.6 mm)
<b>Minimum Bend Radius</b>	2" (51 mm)	2.5" (64 mm)	2" (51 mm)	2.5" (64 mm)	2.5" (64 mm)	3.5" (89 mm)
<b>Working Pressure</b>	3250 PSI (22400 kPa)	3000 PSI (20700 kPa)	3250 PSI (22400 kPa)	3000 PSI (20700 kPa)	3000 PSI (20700 kPa)	3000 PSI (20700 kPa)
<b>Temperature Range</b>	-40°C - +100°C	-40°C - +100°C	-40°C - +100°C	-40°C - +100°C	-40°C - +100°C	-40°C - +100°C
<b>Material</b>	Modified Nitrile Type C2	Modified Nitrile Type C2	Modified Nitrile Type C2	Modified Nitrile Type C2	Modified Nitrile Type C2	Modified Nitrile Type C2
<b>Specialized Construction</b>	Single Wire Braid	Single Wire Braid	Single Wire Braid	Single Wire Braid	Single Wire Braid	Single Wire Braid
<b>Media</b>	Hydraulic Fluid	Hydraulic Fluid	Hydraulic Fluid	Hydraulic Fluid	Hydraulic Fluid	Hydraulic Fluid
<b>Application</b>	Agricultural and Construction	Agricultural; Construction	Agricultural and Construction	Agricultural; Construction	Agricultural; Construction	Agricultural; Construction

### HYDRAULIC HOSE INFORMATION (Continued)

Part Number	A1027	A3152	A11447	A11445	A12753	A11459
<b>Description</b>	Hose Assembly 3/8" x ~462 cm (182") (08F - 08F)	Hose Assembly 3/8" x ~157.5 cm (62") (08F - 08F)	Hose Assembly, 5/8" x ~114 cm (45") (12F - 12F)	Hose Assembly, 5/8" x ~145 cm (57") (12F - 12F)	Hose Assembly 1/2" x ~145 cm (57") (10F - 10F)	Hose Assembly, 5/8" x ~312 cm (123") (12F - 12F)
<b>Product Category</b>	Hydraulic Hose	Hydraulic Hose	Hydraulic Hose	Hydraulic Hose	Hydraulic Hose	Hydraulic Hose
<b>Product Form</b>	Hose; Assembly	Hose; Assembly	Hose; Assembly	Hose; Assembly	Hose; Assembly	Hose; Assembly
<b>I.D.</b>	3/8" (9.5 mm)	3/8" (9.5 mm)	5/8" (~15,88 mm)	5/8" (~15,88 mm)	1/2" (12.7 mm)	5/8" (~15,88 mm)
<b>O.D.</b>	1 1/16" (17.5 mm)	1 1/16" (17.5 mm)	1 5/16" (~23,81 mm)	1 5/16" (~23,81 mm)	1 3/16" (20.6 mm)	1 5/16" (~23,81 mm)
<b>Minimum Bend Radius</b>	2.5" (64 mm)	2.5" (64 mm)	4" (~101,60 mm)	4" (~101,60 mm)	3.5" (89 mm)	4" (~101,60 mm)
<b>Working Pressure</b>	3000 PSI (20700 kPa)	3000 PSI (20700 kPa)	2750 PSI (~18961 kPa)	2750 PSI (~18961 kPa)	3000 PSI (20700 kPa)	2750 PSI (~18961 kPa)
<b>Temperature Range</b>	-40°C - +100°C	-40°C - +100°C	-40°C - +100°C	-40°C - +100°C	-40°C - +100°C	-40°C - +100°C
<b>Material</b>	Modified Nitrile Type C2	Modified Nitrile Type C2	Modified Nitrile Type C2	Modified Nitrile Type C2	Modified Nitrile Type C2	Modified Nitrile Type C2
<b>Specialized Construction</b>	Single Wire Braid	Single Wire Braid	High tensile steel wire	High tensile steel wire	Single Wire Braid	High tensile steel wire
<b>Media</b>	Hydraulic Fluid	Hydraulic Fluid	Hydraulic Fluid	Hydraulic Fluid	Hydraulic Fluid	Hydraulic Fluid
<b>Application</b>	Agricultural; Construction	Agricultural; Construction	Agricultural; Construction	Agricultural; Construction	Agricultural; Construction	Agricultural; Construction



## LEVEL PLANTER

Lateral adjustment is maintained by tire pressure. Check tires are inflated to specification.

Front and rear level adjustment is maintained by hitch clevis position unless tractor drawbar is adjustable for height. Planter frame and row unit parallel arms must be level for proper planter and row unit operation. Bottom of toolbar should be 51 cm to 56 cm from planting surface.

1. Lower planter to planting position and check planter is level front to rear. Go to step 2 if hitch is too high or low.



Level planter toolbars

**NOTE: DO NOT install safety chain using clevis hardware. Move safety chain location if necessary.**

2. Remove clevis hitch hex head cap screw and lock nut using a torque wrench. Replace if off-torque is below 102 Nm or there is corrosion or damage.

**NOTE: Clevis must be free to move on hitch. DO NOT OVERTIGHTEN hardware.**

3. Align clevis to hitch holes at new location and install hex head cap screw and lock nut. Tighten lock nut until threads are fully engaged and hex head cap screw and lock nut are firmly against hitch bracket.

**NOTE: On planters with push row units and no till coulters, uplift from down force springs or air springs in pneumatic down pressure system may cause wings to rise slightly in planting position. Problem may be compounded if static pressure is trapped in planter's hydraulic lift system which can cause wing cylinders to extend slightly. Operating tractor's hydraulic system in float position or moving tractor's hydraulic lever to float position briefly to relieve pressure will help maintain proper toolbar height.**

4. Field check planter.

Field and actual planting conditions dictate which transport wheel setting to use so row unit parallel arms are parallel with ground. It may be necessary to lower ground drive wheels to ensure level lateral toolbar operation if transport wheels are set in one of the two lower sets of holes. Make a field check when planter is fully loaded with seed, granular chemicals, fertilizer, etc. to be sure wings are level with center frame. If wings are not level with center frame, drive wheels and/or transport wheels can be raised or lowered in wheel arms to increase or decrease planter toolbar height. Raise hitch to ensure level operation.

<b>NOTICE</b>	<p>Component interference can damage equipment. Check clearance between tires and drill shaft U-joint when using top hole setting.</p>
---------------	--

**NOTE:** To allow adequate drive force after lowering ground drive wheels, it may be necessary to lower contact drive wheel arms to lower sets of holes in wheel modules and lower down pressure springs to lower mounting rods on wheel modules.

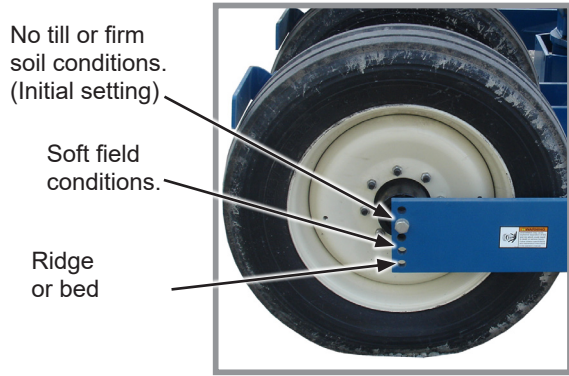

**Transport wheel adjustment**

Keep row unit parallel arms parallel to ground when adjusting wheel heights.

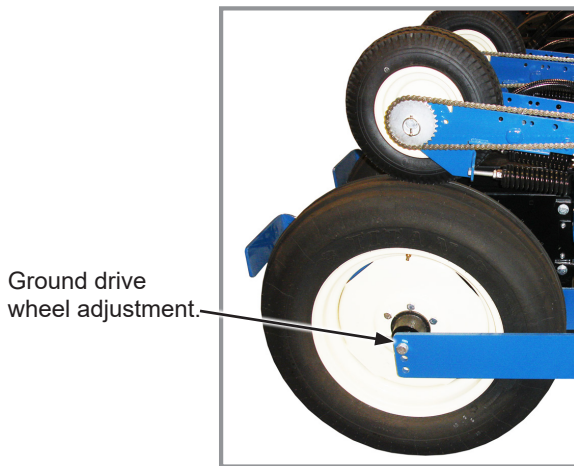
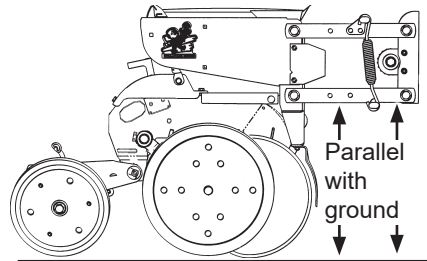

**Ground drive wheel adjustment**

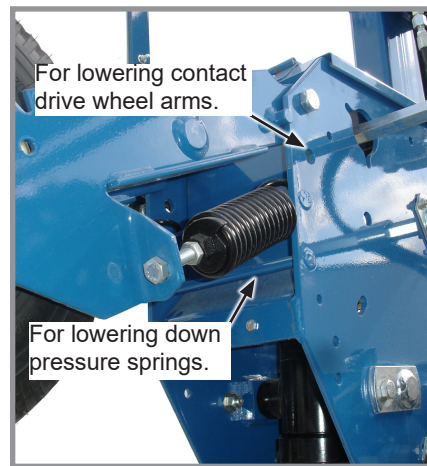

**Contact drive wheel adjustment**

**NOTE:** If setting is changed see basic adjustment procedure under “Contact Wheel Spring Adjustment”

## RIDGE PLANTING

Move drive and transport wheels 5 or 10 cm to lower mounting holes in wheel arms when ridge planting to increase planter toolbar height. Contact drive tire must also be moved to lower set of holes in wheel module and down pressure springs hooked on lower rod. Raise hitch height to ensure level operation.

## CONTACT WHEEL DRIVE SPROCKETS

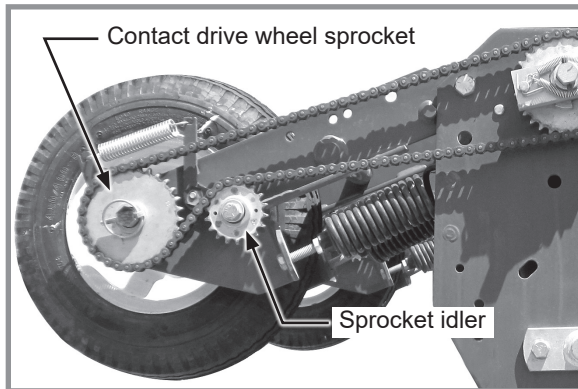

**Contact wheel drive**



**Optional half-rate drive sprocket**

Contact wheel drive works the same for vacuum planters except for sprocket size. Chain tension is controlled by a spring-loaded sprocket idler. Planting rate charts in “Rate Chart” section help you select correct sprockets.

**NOTE: Make a field test after each sprocket combination change to be sure you are planting at desired rate.**

### VACUUM

22 tooth, 28 tooth or 44 tooth sprockets at each contact drive wheel can be exchanged with sprockets on storage rod bolted to wheel module on each side of planter chains.

**NOTE: 22, 28 and 44 tooth drive sprockets do NOT apply to all rate charts. Check chart titles to make sure proper rate chart is selected. DO NOT USE 44 tooth drive sprockets (60 cell soybean discs) with Dry Fertilizer Package or Liquid Fertilizer Squeeze Pump Package.**

**CONTACT WHEEL SPRING ADJUSTMENT**

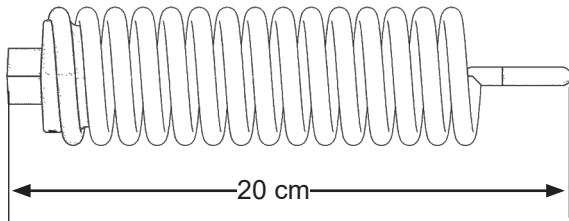

**Spring length measurement (Factory setting)**

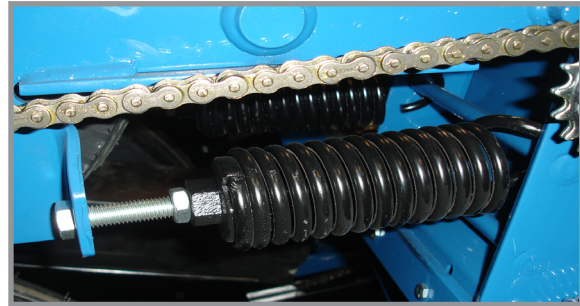

**Contact drive springs**

There are two down pressure springs on each contact drive wheel. Spring tension is factory set to approximately 90 kg of down force at tire contact point and should require no further adjustment.

**NOTE: Measurement must be taken in planting position with proper tire pressure.**

**SEED RATE TRANSMISSION ADJUSTMENT**

Planting population rate changes are made using seed rate transmissions at each end of planter. Seed rate transmission allows quick and easy sprocket changes to obtain desired planting population. Sprockets are exchanged with those from sprocket storage rod bolted to transmission by removing lynch pins on hexagon shafts.

A decal positioned on transmission module illustrates proper chain routing. Planting rate charts found in "Rate Chart" section help you select correct sprocket combinations.

Chain tension is controlled by a spring-loaded dual-sprocket idler adjusted with an easy-release idler arm. This arm has a release position to remove spring tension for replacing sprockets. See "Wrap Spring Wrench Operation" below.

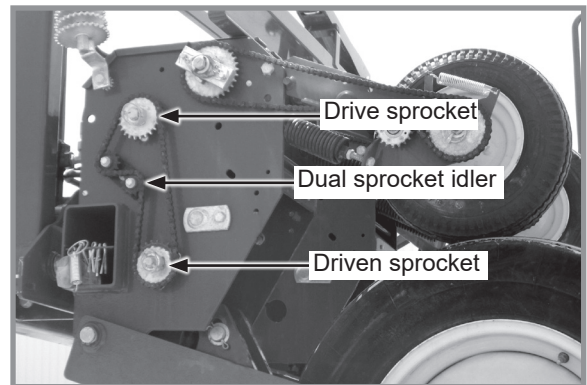

**Seed rate transmission (L.H. shown)**

**WRAP SPRING WRENCH OPERATION**

Chain idlers are equipped with wrap spring wrenches. L.H. wrap spring wrenches have a blue release collar and R.H. wrap spring wrenches have a grey or black release collar.

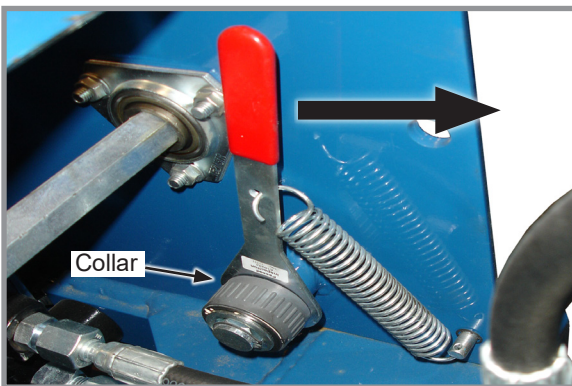

**Wrap spring wrench (R.H. shown)**



**Chain idler tensioning**

Rotate collar on wrap spring wrench and pull handle to release chain tension.

Rotate chain idler into chain and pull handle to tension idler spring.

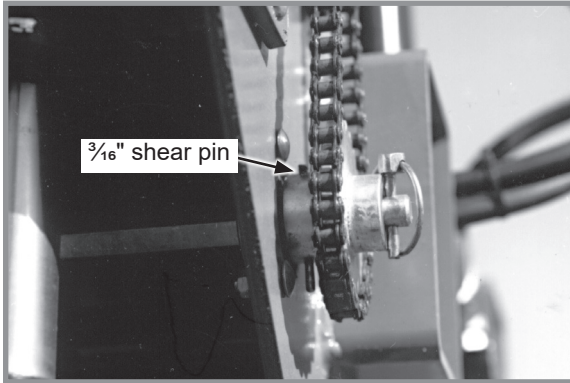
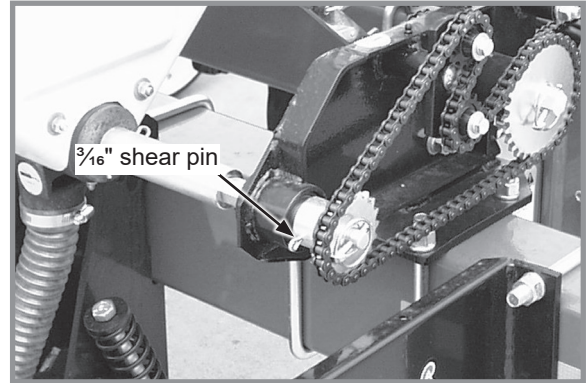
**SHEAR PROTECTION****Transmission shaft****Dry fertilizer attachment transmission**

Shear pins protect planter driveline and row unit components from damage.

1. Determine where binding has occurred before replacing a pin. Turn shaft by hand (with the aid of a wrench) and check for misalignment and seized parts.
2. When shaft can be turned by hand (with the aid of a wrench) replace shear pins with same size and type. Spare shear pins are stored inside ends of rear planter frame.

**NOTICE**

**Misaligned drill shaft/transmission coupler can cause equipment damage.**

3. Check driveline alignment and follow prescribed lubrication schedules to prevent component binding or breakage.

## HYDRAULIC/ELECTRIC OPERATION

Control console switches and tractor's hydraulic system are used to raise planter to transport position, operate rotate and tongue extension functions, lock and release planter wings, and raise and lower row markers.

**NOTE:** Turn console backlighting OFF during extended periods of non-use using push button switch on back of console.



Single point row clutch control box

Model 3605 planters operate from three dual remote (SCV) hydraulic outlets and tractor mounted control console. One SCV and a control console switch operate raise to transport function. A second SCV and control console switches operate row markers and fold/unfold functions. A third SCV operates vacuum fan motor circuit.

Marker and point row selector switches are an ON-OFF-ON type. If planter is equipped with optional Two-Speed Point Row Clutch Package, point row switch and reduced rate switch operate independently from rest of control console.

Power to marker switch is fed through auxiliary switch and two transport function switches. Operating any lower row switch disables markers and turns off marker indicator light.

Raise/wing lock and rotate/tongue (fold function) switches are MOMENTARY ON-OFF-MOMENTARY ON type and must be held in position while operating tractor hydraulic SCV control. Activating a fold function switch disables marker circuit.

 <b>WARNING</b>	<b>Marker selector switch must be OFF (center position) when not in use to prevent accidental extension which could result in death or serious injury, or damage to property and equipment. An indicator light on control box panel is ON whenever marker circuits or point row clutch circuits are energized.</b>
--	--

Auxiliary switch is an ON-OFF type switch used with hydraulic marker/folding functions SCV control to operate optional attachments. Auxiliary switch must be OFF to enable other functions.

**NOTE: Activating auxiliary switch disables all other control console switches except point row clutch switch.**

**NOTE: Lift cylinders are (port type) rephasing cylinders. Cylinders must fully retract before they rephase in lowered position. Cylinder stops cannot be used.**

A third SCV operates the vacuum seed metering system vacuum fan. See "Digital Vacuum Gauge Operation".

**TRANSPORT TO FIELD SEQUENCE**

Position planter in a relatively flat open area. Avoid an area with furrows, etc.

**SUMMARIZED TRANSPORT TO FIELD SEQUENCE**

- Remove tongue safety pin.
- Remove transport latch locking pin.
- Remove manual safety lockup.
- Rotate planter to planting position.
- Raise planter slightly to release safety hook at top of center section.
- Lower planter to ground.
- Release wing locks.
- Rephase planter lift cylinders.
- Raise planter to raised field position and retract tongue.
- Remove row marker lockups.

NOTE: Read following information for detailed instructions.

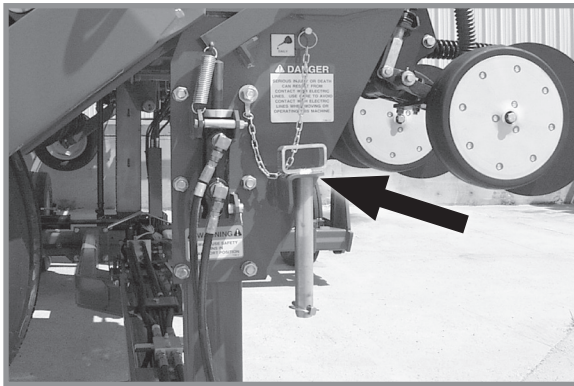

**Tongue safety pin in storage position**

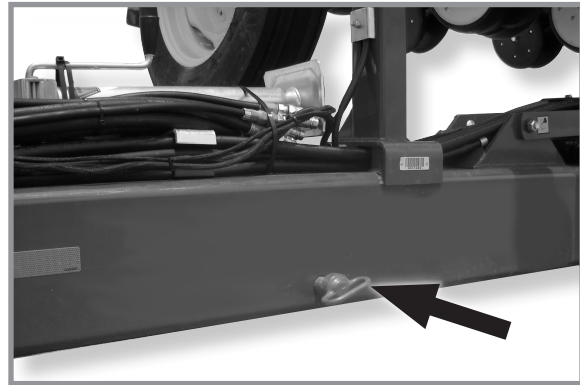

**Tongue safety pin in transport position.**

1. With tongue fully extended and planter in raised transport position, remove tongue safety pin and place it in storage position.

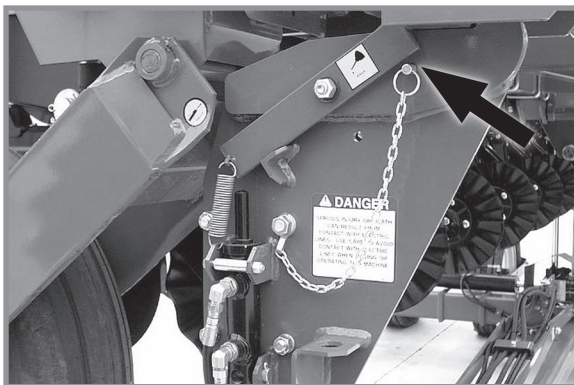

**Transport latch locking pin  
Locked transport position**

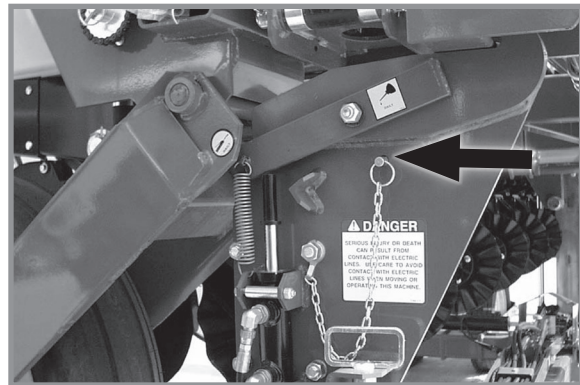

**Transport latch locking pin  
Storage position**

2. Remove transport latch locking pin from locked position and place it in storage location.



- Remove manual safety lockup from under front center lift cylinder and place it in storage location on left side of planter hitch.

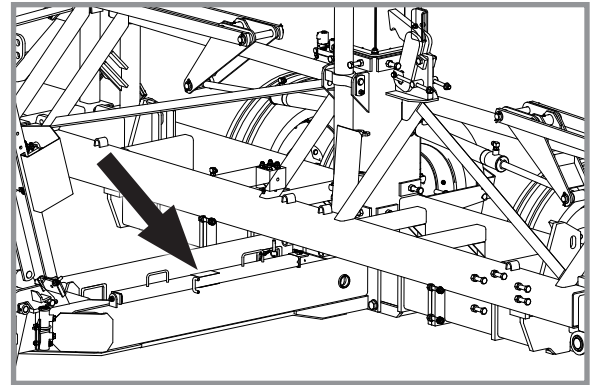

Storage position

- Hold control console “ROTATE/TONGUE” switch in “ROTATE” and operate hydraulic control to unfold planter. Transport latch automatically releases.



Rotate from transport to field

- Raise planter 2½ to 5 cm. Safety hook will release and snap away from catch pin on top of pivot post.

**NOTE: Raising planter too high resets hook mechanism and sequence must be repeated.**

- Slowly lower planter to ground.

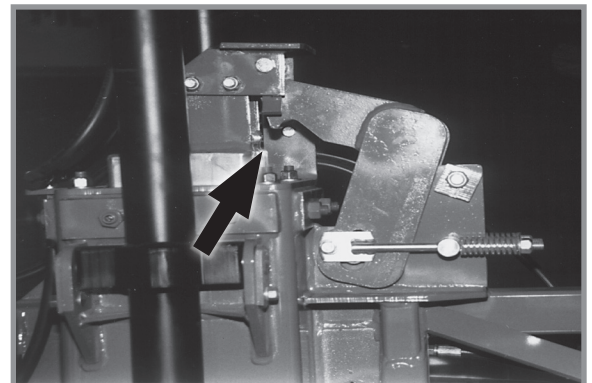

Safety hook release

- Hold control console “RAISE/WING LOCK” switch in “WING LOCK” position and operate hydraulic control to release wing locks.

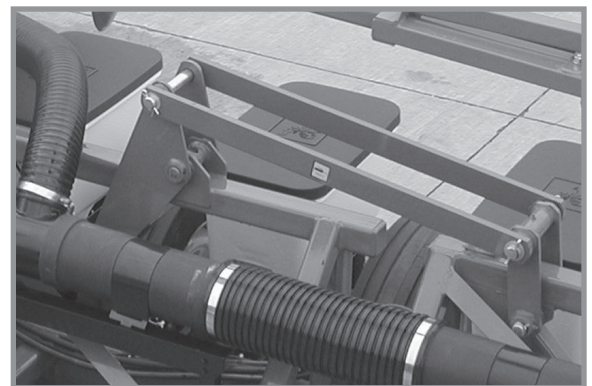

Wing lock

8. Hold hydraulic control (to lower planter) to rephase planter lift cylinders. Time to rephase system may vary due to tractor hydraulic flow and/or oil temperature. Normally 5 to 20 seconds is adequate to rephase system.
9. Raise planter to raised field position. Hold control console ROTATE/TONGUE switch in **TONGUE** and operate hydraulic control to retract tongue.



Retract tongue

10. Remove row marker lockups.

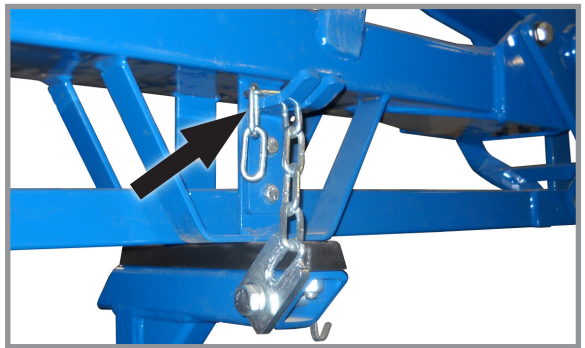

Row marker lockup

## FIELD OPERATION

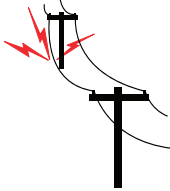
 <b>DANGER</b>	<p>Contacting or coming close to power lines or other high energy sources will cause death or serious injury.</p>
	<p>Keep away from power lines or high energy sources at all times.</p>

<b>NOTICE</b>	<p>Raise planter out of ground when making sharp turns or backing up or equipment damage may result.</p>
---------------	--

There are two raised positions on planter. Transport position is when the planter is fully raised. Raised field position is when planter wing cylinders are fully extended and center lift cylinders are at mid-stroke. In “raised field position” row units are approximately 35.5 cm off ground. This position is used in making turns or passing over waterways during field operation.

An oil bypass solenoid is located on top side of valve blocks on rear R.H. side of center frame. This solenoid is not energized in raised field position so wing cylinders cannot bypass oil preventing planter from raising any higher.



**Raised field position**

## PLANTING SPEED

Planters are designed to operate in a speed range of 3 to 13 km/h. Higher ground speeds generally cause more variation in seed spacing. Speeds above 9 km/h are typically not recommended. See “Rate Charts”

## FIELD TO TRANSPORT SEQUENCE

Position planter in a relatively flat area. Avoid areas with furrows, etc.

### SUMMARIZED FIELD TO TRANSPORT SEQUENCE

- Install row marker lockups.
- Raise planter to raised field position.
- Extend tongue.
- Lock wings over center
- Raise planter to engage safety hook at top of center section into locking position.
- Lower planter onto safety hook.
- Rotate planter to transport position.
- Install tongue safety pin.
- Install transport latch locking pin.
- Install manual safety lockup.

**NOTE:** Read following information for detailed instructions.

1. Install row marker lockups.
2. Raise planter to raised field position using hydraulic control.



Row marker lockup

3. Hold "ROTATE/TONGUE" switch in "**TONGUE**" and operate hydraulic control until tongue is fully extended. Tongue lock latch automatically releases.

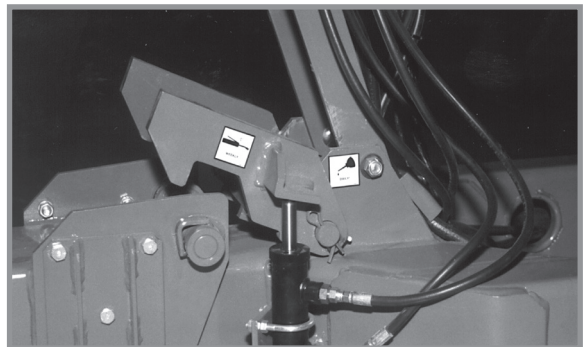

Tongue latch lock

4. Hold "RAISE/WING LOCK" switch in "**WING LOCK**" and operate hydraulic control until wing lock cylinders are fully extended and wing locks are locked over center.



Wing lock

5. Hold control console “RAISE/WING LOCK” switch in “**RAISE**” and operate hydraulic control until two center lift cylinders are fully extended and safety hook at top of center section rotates into locking position.
6. Lower planter onto safety hook using hydraulic control.

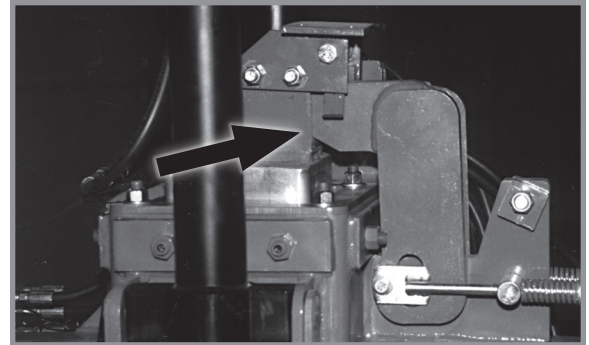

Center section safety hook



## WARNING

Uncontrolled movement of equipment can cause loss of control and could result in death, serious injury, or damage to property and equipment. Install all safety pins before transporting equipment.

7. Hold control console “ROTATE/TONGUE” switch in “**ROTATE**” and operate hydraulic control to rotate planter until transport latch is engaged.
8. Install tongue safety pin.

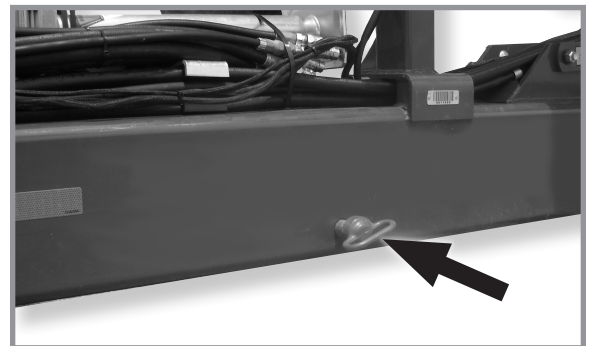

Tongue safety pin

9. Install transport latch locking pin.

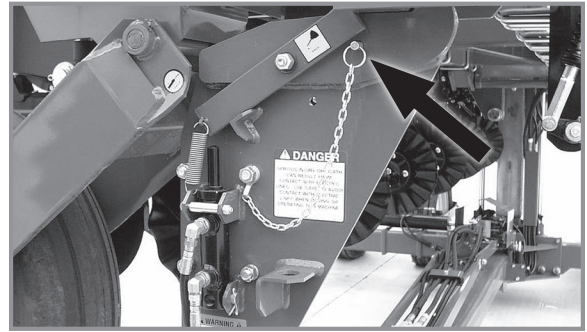

**Transport latch locking pin installed**

10. Remove manual safety lockup from storage location on left side of axle hitch and position it behind front center lift cylinder.

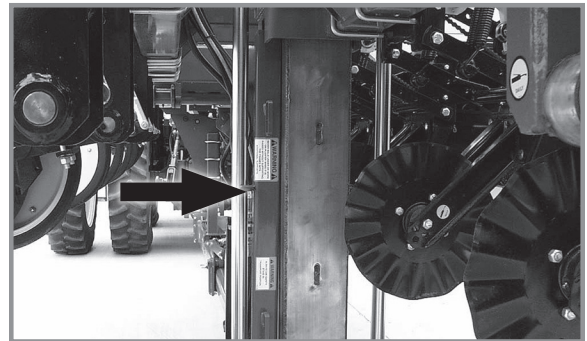

**Manual safety lockup installed**

---

**TRANSPORT TO FIELD SEQUENCE USING BLUE VANTAGE****NOTICE**

Tractor must be in neutral and allowed to roll freely when unfolding to prevent equipment damage, especially in soft conditions or when loaded with seed. Use tractor assist as needed to aid in unfolding and to reduce stress on frame and transport components.

**NOTICE**

DO NOT fold or unfold planter without planter attached to a tractor. DO NOT unhitch planter from tractor unless fully folded for transport or fully unfolded with planting units lowered to ground.

**WARNING**

Improperly operating or working on this equipment could result in death or serious injury. Make sure there is no one in the area of the moving parts of the planter.

1. Remove lockups.
2. Press and hold "ROTATE TRANSPORT AXLE". Operate proper hydraulic tractor control to lower transport axle to field turnaround position.
3. Press and hold "LOWER WING WHEELS". Operate proper hydraulic tractor control to lower wing wheels into field turnaround position.
4. Press and hold "LOWER HITCH". Operate proper hydraulic tractor control to unhook the wings.
5. Press and hold "UNFOLD". Operate proper hydraulic tractor control to move wing out, away from tractor. Planter is completely unfolded when stub wings are latched into the H-frame.

**Note: Place tractor in reverse and slowly reverse when unfolding to prevent damage to wheel arm.**

6. Lower planter and hold hydraulic lever for an additional 30 seconds to rephase lift cylinders.
7. If equipped with row markers, remove lockups and place in storage position.
8. Lower hitch to level machine during planting.

**For more information, refer to the Blue Vantage Manual supplied with the planter.**

## VACUUM SYSTEM

Kinze vacuum seed metering system includes seed meters, seed discs, and an air system consisting of a hydraulic driven vacuum fan which draws air through manifolds, hoses, and seed meters on each row unit.

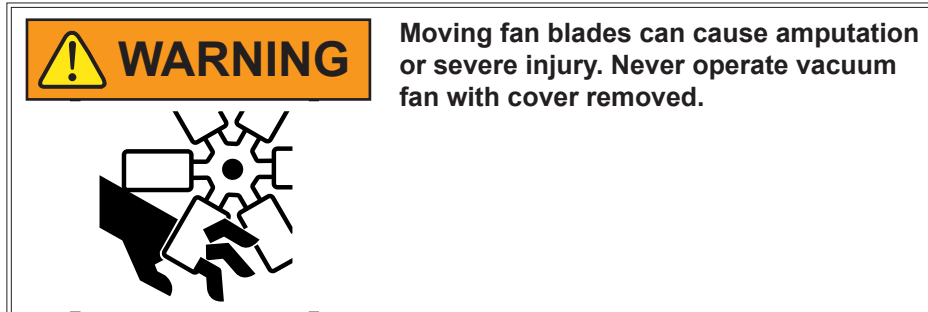

## DIGITAL VACUUM READOUT

Digital vacuum readout is incorporated into Kinze Vision displays. Refer to their operation manuals for instructions.

## VACUUM FAN MOTOR VALVE BLOCK ASSEMBLY

A pressure relief valve in the hydraulic circuit prevents build up of oil pressure over 35 PSI (241 kPa) in case drain line when vacuum fan motor is operating. This valve will vent oil outside valve block through a drain hole in the aluminum valve block. This can occur whenever case drain is improperly connected or pressure in motor circuit builds.

See "Hydraulic Schematic - Vacuum Fan Motor System" on page 6-52.

Valve block contains a check valve that prevents vacuum fan from operating in wrong direction if pressure is applied to return side of motor and allows fan to coast to a stop when tractor hydraulic control is returned to neutral position.

**NOTE: Fan turns at a reduced speed if reverse pressure is applied.**

**NOTE: Analog gauges are identical EXCEPT for plug and hose barb locations in side of gauge housing. DO NOT connect vacuum or bulk fill hose to wrong gauge. Check plug and hose barb installation if readout is erratic or appears inaccurate.**

## ANALOG VACUUM OR PRESSURE GAUGE

The analog vacuum or pressure gauge connects directly to the vacuum and is teed into the digital sending units.

Only adjustment is to "zero" needle with no vacuum or pressure present. If there is a significant difference between gauge and a reading taken at meters, a different manifold location should be found to connect hose to gauge and digital sending unit.

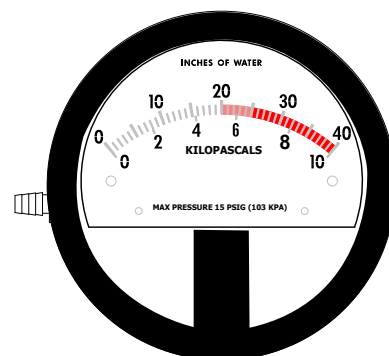

Analog gauge



## BULK FILL SYSTEM



### CAUTION

Seed flying out of disconnected delivery tube at high velocity can cause injury. Do not disconnect delivery tubes when system is operating.

### NOTICE

Foreign materials can plug system. Make sure seed is clean and free of debris when filling bulk fill hoppers.

### NOTICE

Do not turn on system with tractor engine at full speed or system damage may occur.

### NOTICE

Do not operate bulk fill system above maximum system operating pressure of 20 inches of water (51 cm of water) or seed bridging may occur.

1. **Before filling hoppers refer to “Row Unit Operation” for additives information.** Fill hoppers with seed, latch lids, and secure with pin.
2. Start bulk fill system with tractor engine at idle.
3. Increase engine speed to full and set initial system pressure using flow control valve.
4. Allow system to warm up and adjust pressure if necessary.

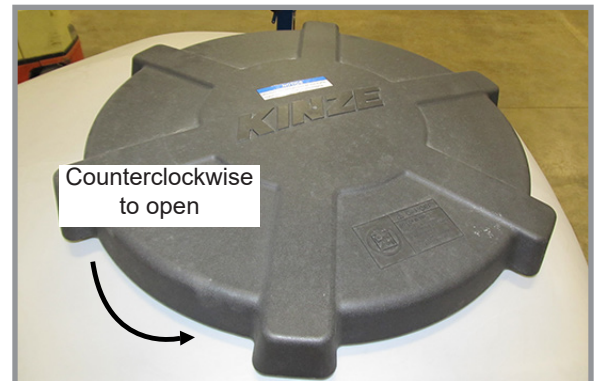

**Bulk fill tank lid latch**

Recommended pressures:

For specific pressures for each seed, See "Vacuum Settings" on page 3-12.

## BULK FILL ENTRAINER ACCESS

1. Shut down bulk fill system.
2. Loosen wing nut and turn retainer holding shutoff door in its storage location.
3. Remove rubber plug closest to area in entrainer needing attention.
4. Insert shutoff door into open slot and push into entrainer at a slight upward angle.
5. When work is complete, remove shutoff door, return door to storage location, and plug open slot.

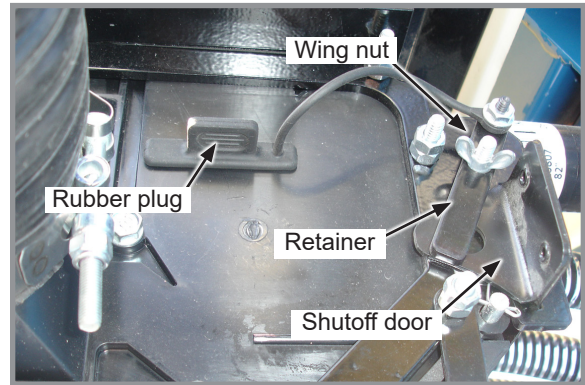

**Bulk fill entrainer (end view)**

## BULK FILL TANKS - CLEAN OUT

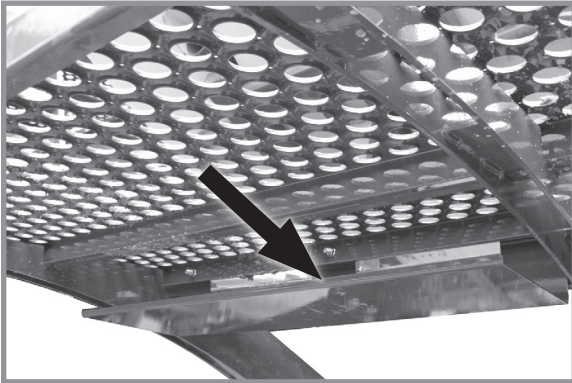

**Cleanout chute storage bracket**

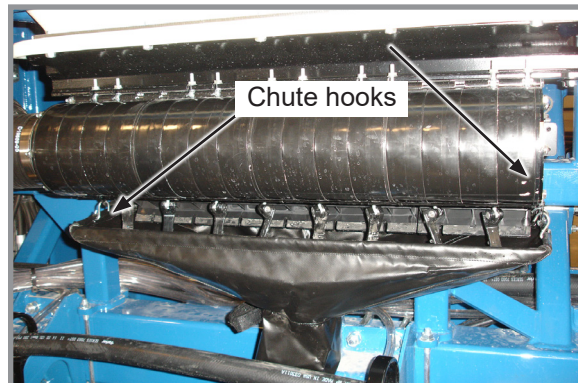

**Cleanout chute installed**

1. Remove bulk fill tank cleanout chute from storage location beneath catwalk.
2. Position tube of chute under entrainer and attach hooks on each end of entrainment assembly.
3. Open cleanout doors and empty tank.
4. Close all cleanout doors and return cleanout chute to storage location.

**BULK FILL SCALE PACKAGE OPTION****NOTICE**

High-pressure water can damage display. Remove display before power washing planter.

**NOTICE**

Remove and store display at end of planting season. Damage from sun and weather exposure may result.

Bulk Fill Scale Package is capable of:

- Displaying seed weights and estimated acres remaining for bulk fill hoppers separately.
- Setting alarm to warn operator when seed goes below a pre-defined level.

NOTE: Operation of Bulk Fill Scale Package display is controlled by touchscreen.

NOTE: Screen position is changed by loosening the thumb screw on RAM™ mount.

**STORAGE**

At end of planting season, remove display. Otherwise damage from sun and weather exposure may result.

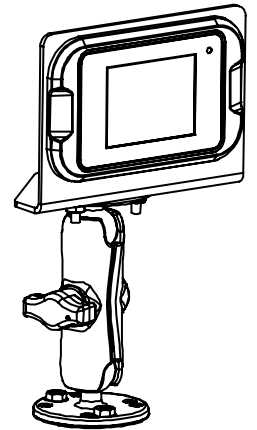

To monitor seed levels (Main Screen):

**NOTE: Only applicable to Ag Leader InCommand, refer to Blue Vantage manual for bulk fill scale user information.**

1. Main screen displays information for left and right hoppers.
2. Tap "Weight" to display left and right hopper weight.
3. Tap "Area to Empty" to display left and right acres to empty.

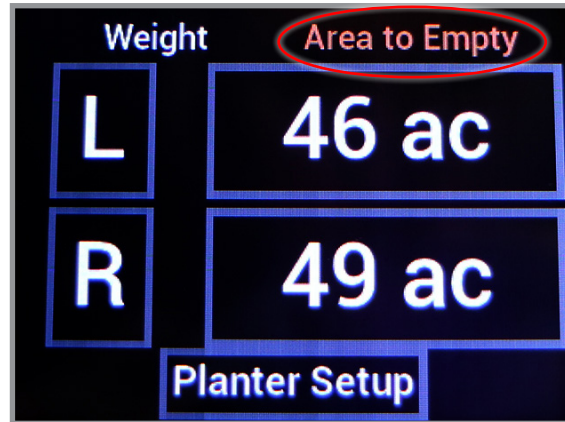

4. Tap either "L" or "R" to display detailed hopper screen.

**NOTE: "Zero" is selected to zero hopper that is selected. If hopper(s) is zeroed out with seed, weight in hopper will not be recognized. To reset hopper correctly seed must be emptied from hopper(s) and then zeroed to reset.**



5. Tap "Back" to return to main screen.
6. Tap "Planter Setup" to enter Seed information. See follow page for more information.

To enter seed information (Not applicable on Blue Vantage):

**NOTE:** Seed information entered must be accurate for remaining estimated acres to calculate correctly.

- SEEDS/ACRE is population rate.
- SEEDS/LB value comes from seed specifications.

1. From main screen, tap "Planter Setup".
2. From planter setup screen, tap "Seed Setup".

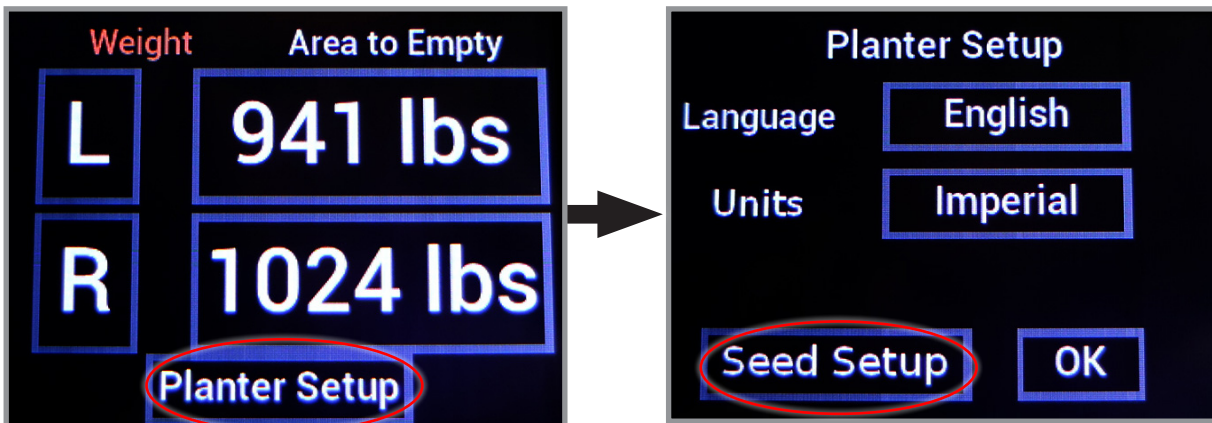

3. To change values in either "Seeds/Ac", "Seeds/lb", or "Alarm Level" tap in appropriate box.
4. At input screen, enter desired value. Tap "OK".

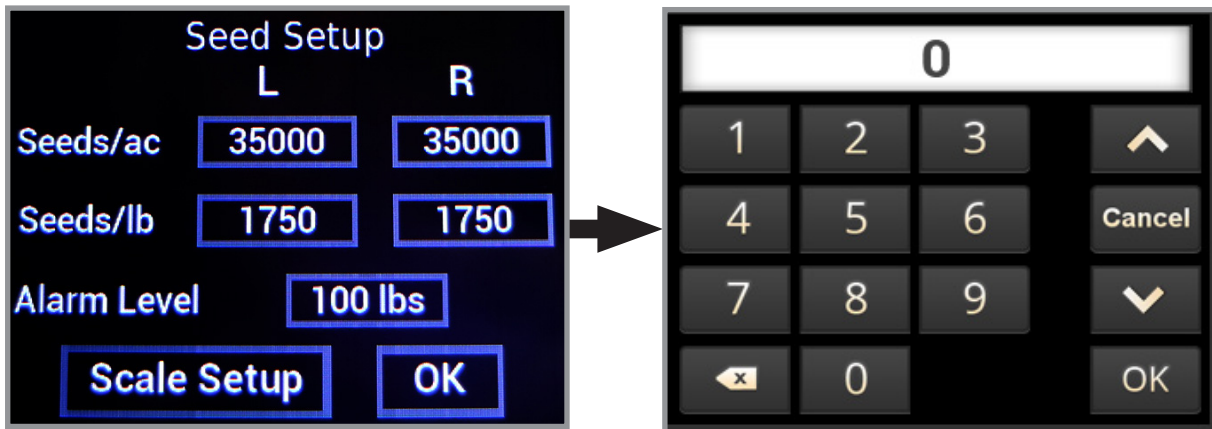

5. Once desired values have been entered tap "OK", to confirm changes tap "Accept" to return to main screen.

**NOTE:** It is NOT RECOMMENDED to make adjustments to setup in the "Scale Setup" screen.

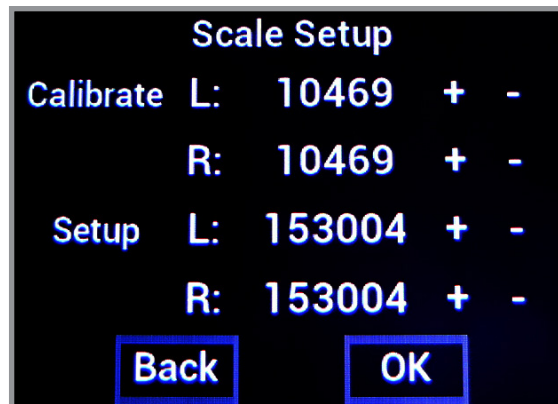

**Software Version:**

1. From main screen, tap "Planter Setup".
2. Tap on "English" to display software version.

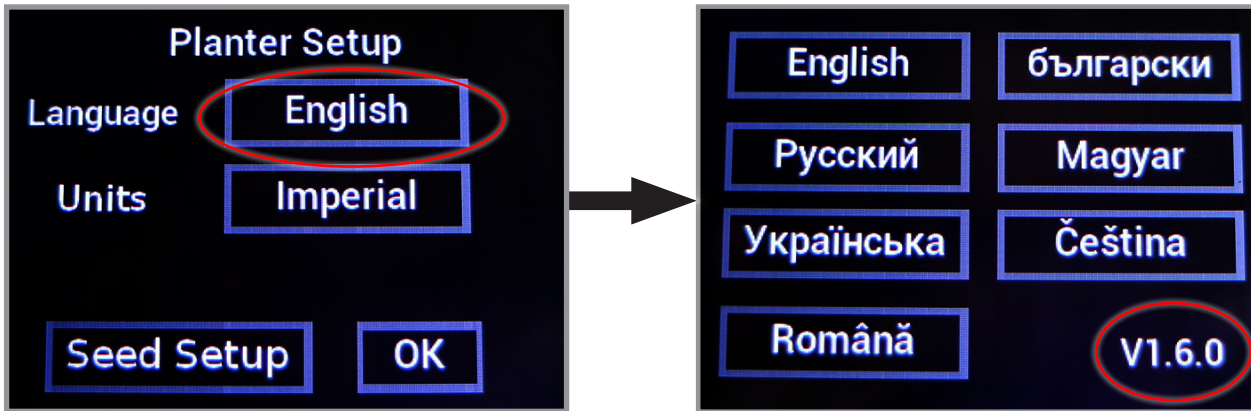

4. Tap "English" to return to planter setup screen.
3. Tap "OK" to return to main screen.

**Language/Units:**

**NOTE: English is the default language. Imperial is the default units.**

1. From main screen, tap "Planter Setup".
2. Tap on "English" to display language options.

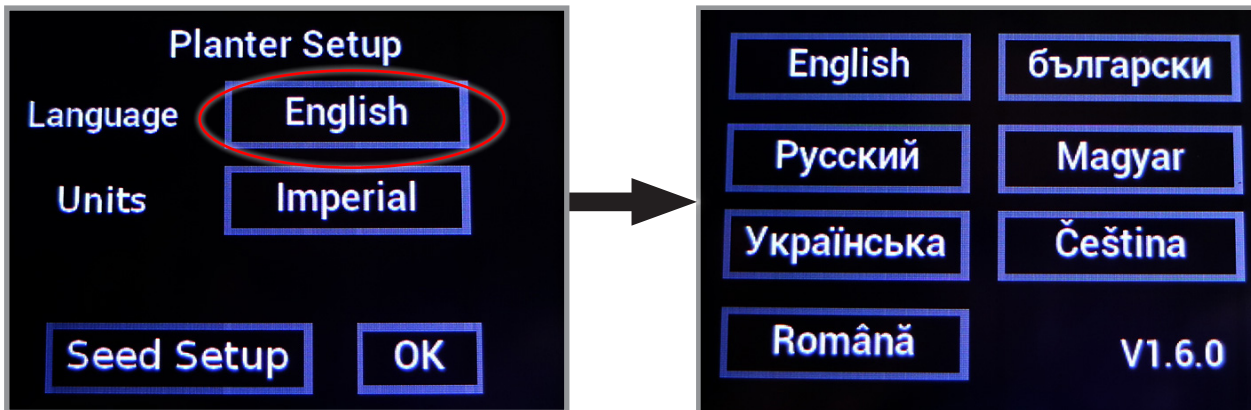

3. Tap on desired language to select and return to planter setup screen.
4. Tap on "Imperial" to switch to metric units and vice versa.

**NOTE: If units are switched back and forth between imperial and metric, measurements will round up each time.**

3. Tap "OK" to return to main screen.

## AG LEADER INTEGRA DISPLAY

INTEGRA is a full-featured hub of any precision farming operation. A large, full-color 12.1" HD touchscreen display is easy to read and offers powerful, year-round precision farming tools. Mapping, planter and application control, yield monitoring, real-time data logging, and more – are all controlled from the cab using the Integra display.

Four video camera inputs provide operators a better view of equipment operation and safety by allowing them to view live video on the display.



Ag Leader Integra display

**NOTE: See Integra operator manual for installation and programming.**

## AG LEADER MONITORING CONTROL (PMM)

The PMM Magnetic Distance Sensor Package includes a planter-mounted module enclosure with cover and mounting hardware, seed tubes w/sensors, planter harness, planter monitor cable, shaft rotation sensors and magnetic distance sensor components.

Ag Leader Integra display and associated cab harnesses are also required.



Planter monitor module (PMM)

## AG LEADER INCOMMAND 1200 DISPLAY

The InCommand 1200 is a full-featured display for any precision farming operation. A large, full-color 12.1" HD touchscreen display is easy to read and offers powerful, year-round precision farming tools. Mapping, planter and application control, yield monitoring, real-time data logging, and more – are all controlled from the cab using the InCommand display.

Four video camera inputs provide operators a better view of equipment operation and safety by allowing them to view live video on the display.

**NOTE: See InCommand operator manual for installation and programming.**



Ag Leader InCommand Display

## KINZE BLUE VANTAGE

Blue Vantage can be ready to plant in three taps after proper setup. The health screen provides all critical planting parameters and controls. The grower can observe row-by-row planting performance in real-time.

**NOTE: See Kinze Blue Vantage Operator's Manual for system operation and programming.**



Kinze Blue Vantage

## ROW MARKER OPERATION

**DANGER**

Contacting or coming close to power lines or other high energy sources will cause death or serious injury.

Keep away from power lines or high energy sources at all times.

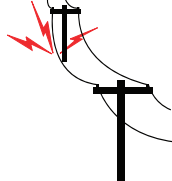



**Marker switch**

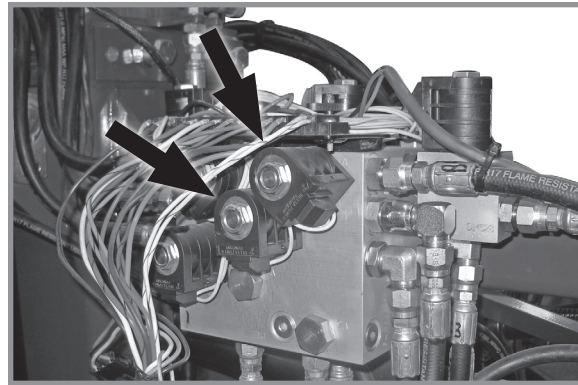

**Row marker solenoid valves (Cover removed)**

Two solenoid valves on valve block at rear R.H. side of center frame, and a three position selector switch on control console permit operator to lower or raise desired row marker.

**NOTICE**

**Marker position switch must be OFF when planter is not in use or tractor battery will drain.**

See “Row Marker Speed Adjustment”.

1. Select which row marker to lower on control console.
2. Operate hydraulic control to lower row marker.
3. Move control switch to other side to operate opposite row marker.
4. Raise row marker at end of field using hydraulic control.
5. After turn, using the hydraulic control, lower the pre-selected row marker.
6. Continue to follow this procedure.

**NOTE: Both row markers can be lowered by operating switch in each position and hydraulic control twice. Row markers raise simultaneously with hydraulic control in raise position.**

If electrical system does not operate properly:

- Check fuse.
- Check wiring connections.
- Check control switch.
- Check solenoid. SOLENOID HOUSING IS MAGNETIZED WHEN ENERGIZED.



## ROW MARKER SPEED ADJUSTMENT

### NOTICE

Excessive row marker travel speed can damage row markers. Adjust flow controls before row markers are first used.

Marker hydraulic system includes two flow control valves. One flow control valve sets lowering speed and one sets raising speed of both markers. Flow controls determine amount of oil flow restriction through valves, varying marker travel speed.

Loosen jam nut and turn control clockwise, or IN to slow travel speed. Turn counterclockwise, or OUT to increase travel speed. Tighten jam nut after adjustments are complete.

**NOTE: Tractors with flow control valves. Make row marker speed adjustment with tractor flow controls in maximum position. After row marker speed is set, adjust tractor flow controls to allow hydraulic control to stay in detent during marker raise or lower cycle.**

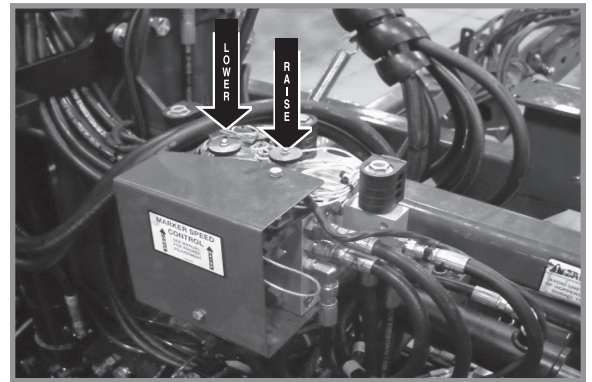

Row marker speed control adjustment

**NOTE: Hydraulics operate slowly when oil is cold. Make all adjustments with oil warm.**

**NOTE: On a tractor where oil flow cannot be controlled, tractor flow rate may be greater than rate marker cylinder can accept. Hold tractor hydraulic control lever until cylinder reaches end of its stroke. This occurs most often on tractors with an open center hydraulic system.**

## EVEN-ROW PUSH ROW UNIT

An Even-Row Push Row Unit Package is available to add one additional push row unit on outer L.H. side of front toolbar for use with Split Row Package.

**NOTE: See “Row Marker Adjustment” for determining correct length to set row marker assemblies when planting with even-row push row unit option.**

**NOTE: install hitch onto 2-point hitch bar using R.H. hole if 2-Point Hitch Option is used. A 19 cm offset mount is not needed. See “Offset Hitch Adjustment” for additional information.**

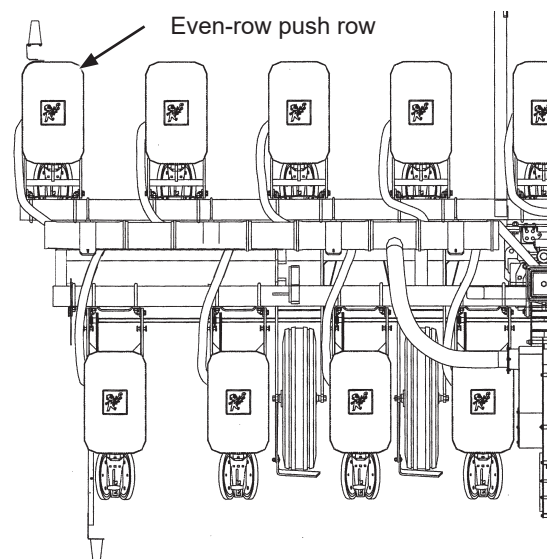

## ROW MARKER ADJUSTMENTS

1. Multiply number of rows by the average row spacing in centimeters to determine total planting width.

Row Marker Lengths	
12 Row 70 cm	8.40 m
16 Row 70 cm	11.20 m

2. Lower planter and row marker assembly to ground.
3. Measure from planter center line to a point where blade contacts ground.
4. Adjust row marker extension so distance from marker disc blade to center line of planter is equal to total planting width. Adjust right and left row marker assemblies equally and securely tighten clamping bolts.

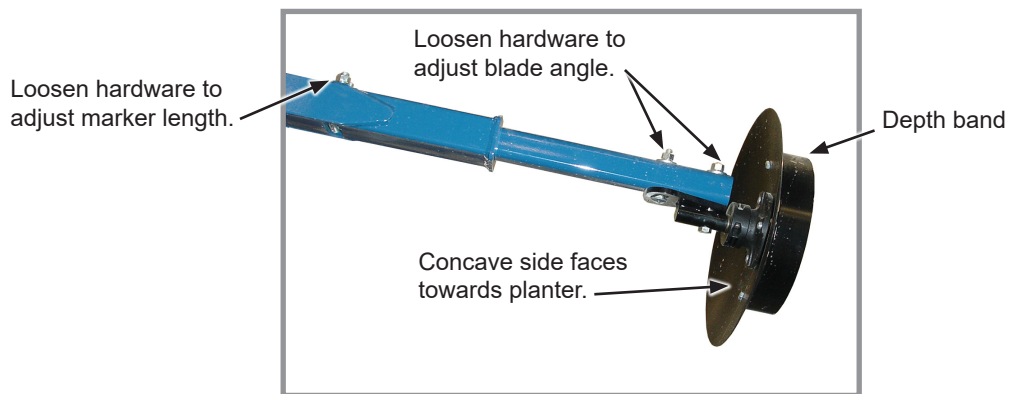

Row marker disc blade angle adjustment

### NOTICE

Setting marker disc blade assembly at a sharper angle than needed adds stress to row marker assembly and shortens bearing and blade life. Set blade angle only as needed to leave a clear mark.

Marker disc blade is installed with concave side facing inward. Spindle assembly is slotted so hub and blade can be angled to throw more or less dirt.

5. Loosen hardware and move assembly as required.
6. Tighten bolts to specified torque.
7. Do a field test to ensure markers are properly adjusted.

**NOTE: A notched marker blade is available from Kinze through your Kinze Dealer for use in more severe no till conditions.**

### ROW MARKER EVEN-ROW LENGTH ADJUSTMENT

Adjust marker extensions as shown below when using even-row push row unit option.

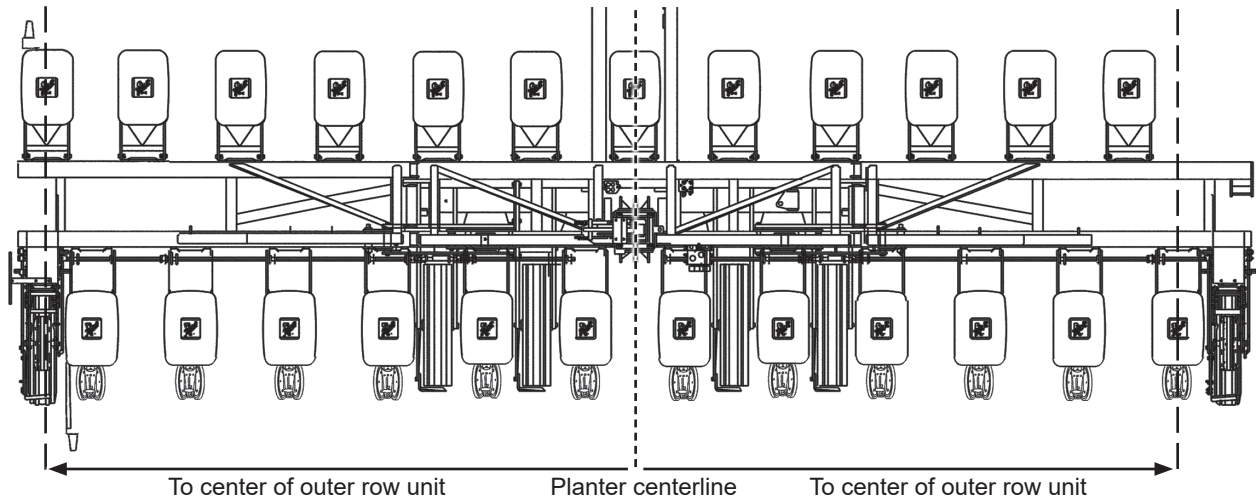

Center Of Planter To Center Of Outer Row Unit x 2 + 35 cm Row Spacing = Dimension Between Planter Center Line And Marker Blade

- 12 Row 70 cm with 12 Split Row Push Row Units  
(L.H. Marker 420 cm x 2 + 35 cm = 875 cm)  
(R.H. Marker 385 cm x 2 + 35 cm = 805 cm)
- 16 Row 70 cm with 16 Split Row Push Row Units  
(L.H. Marker 560 cm x 2 + 35 cm = 1155 cm)  
(R.H. Marker 525 cm x 2 + 35 cm = 1085 cm)

Number Of Rows x Row Spacing (centimeters) = Dimension Between Planter Center Line and Marker Blade  12 Rows x 70 cm Spacing = 840 cm Marker Dimension 16 Rows x 70 cm Spacing = 1120 cm Marker Dimension
--

### OFFSET HITCH ADJUSTMENT

If tractor hitch is offset 19 cm right of tractor center line, add 19 cm to marker dimension on R.H. side of planter and subtract 19 cm from marker dimension on L.H. side of planter.

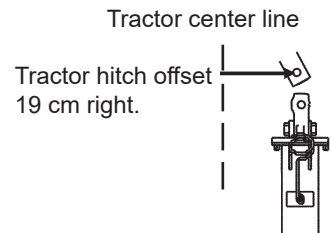

**POINT ROW CLUTCHES**

L.H. point row clutch switch  
10 amp time delay fuse

R.H. point row clutch switch  
10 amp time delay fuse



Single point row clutch control box

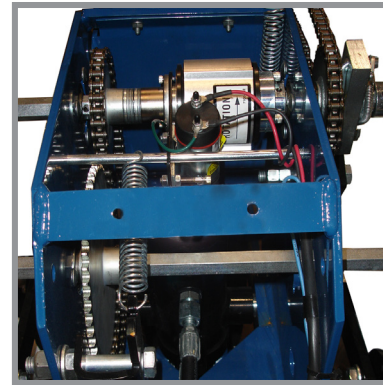

Point row clutch

**NOTICE**

Switch must be OFF when planter is not in use or tractor battery will be drained.

**NOTE:** Liquid fertilizer piston pump has its own drive wheel and is not affected by point row clutch.

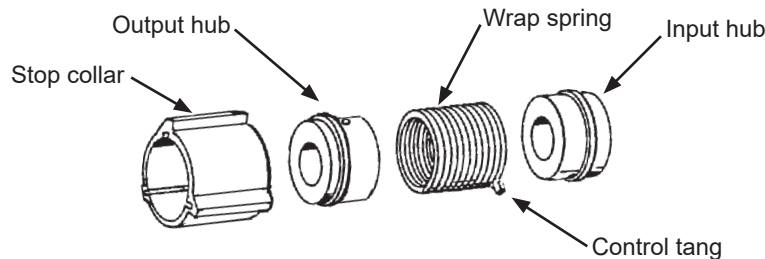

Clutch consists of a wrap spring riding on an input and output hub. Wrap spring is wrapped tightly over hubs during operation locking them together. Higher speeds create a tighter grip of spring on hubs.

Input end of spring is bent outward and is called the control tang. Control tang fits into a slot in stop collar located between input and output hubs over wrap spring. If stop collar is allowed to rotate with input hub, clutch is engaged. If stop collar is stopped from rotating, control tang connected to it is forced back and spring opens. This allows input hub to continue rotating without transmitting torque to output hub, stopping planter drive.

Stop collar is controlled by an electric solenoid and an actuator arm. When selector switch on tractor control box is OFF, solenoid coil is NOT ENERGIZED and actuator arm will not contact stop on stop collar, allowing it to rotate with hubs and drive planter.

When operational switch is in "DISENGAGE" (right or left) solenoid coil IS ENERGIZED and plunger in solenoid coil pulls actuator arm against stop on stop collar, disengaging wrap spring and stopping planter drive.

## AUXILIARY HYDRAULIC OPTION

A customer-supplied auxiliary hydraulic option provides 38 L/min of oil flow at rear of planter for powering fertilizer attachments, bulk seed handling equipment, etc. Two customer-supplied solenoid valve kits (G1K275) are required to activate auxiliary hydraulic option with control console auxiliary switch.



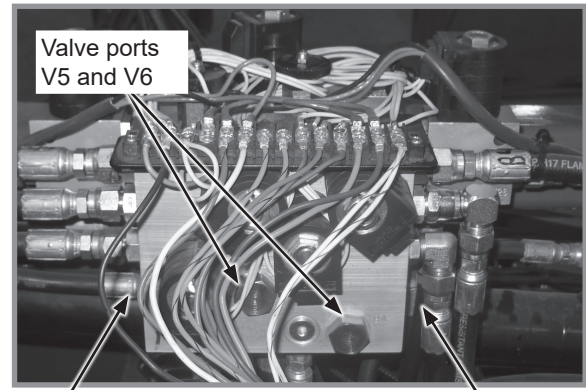

Auxiliary switch



Hydraulic ports  
A9 and B9

Hydraulic ports  
A8 and B8

Valve block on rear center frame (Cover removed)

 <b>WARNING</b>	<p>Pressurized hydraulic fluid can penetrate body tissue and result in death, serious infection, or other injuries. Fluid injected under skin must be <b>IMMEDIATELY</b> removed by a surgeon familiar with this type of injury. Make sure connections are tight and hoses and fittings are not damaged before applying system pressure. Leaks can be invisible. Keep away from suspected leaks. Relieve pressure before searching for leaks or performing any system maintenance.</p>
	

**NOTE: Place row markers in transport position and remove all pressure from hydraulic system.**

Remove cover from valve block on rear center frame of planter. Remove plugs from ports V5 and V6 and install solenoid valve assemblies following installation instruction supplied with each kit. Connect power to solenoid assemblies to orange/black wire located in wiring harness connection to L.H. side of valve block.

Remove plugs from  $\frac{3}{4}$ "-16 O-ring ports A8 and B8 on R.H. side of valve block or ports A9 and B9 on L.H. side of valve block. Connect customer supplied hydraulic hoses.

Refer to "Hydraulic System Schematics" and "Electrical Wiring Schematics" in Lubrication and Maintenance section of this manual for additional information.

**NOTE: Auxiliary switch ON disables all other control console switches.**

Before operating auxiliary system make sure marker switch on control console is OFF. Move auxiliary switch to ON. Operate hydraulic control (marker/folding functions) to engage auxiliary system.

## FIELD TEST

Perform a field test with any change of field and/or planting conditions, seed size or planter adjustment to ensure proper seed placement and operation of row units.

- Check planter for front to rear and lateral level operation. See “Level Planter”.
- Check **all** row units to be certain they are running level. Row unit parallel arms should be approximately parallel to the ground when planting.
- Check row markers for proper operation and adjustment. See “Row Marker Adjustment” and “Row Marker Speed Adjustment”.
- Check for proper application rates and placement of granular chemicals on **all** rows. See “Field Check Granular Chemical Application”.
- Check for desired depth placement and seed population on **all** rows. See “Field Check Seed Population” and appropriate Rate Chart.
- Check for proper application rates of fertilizer on **all** rows. See proper “Fertilizer Application Rate Chart”.

Reinspect machine after field testing.

- Hoses and Fittings
- Bolts and Nuts
- Cotter Pins and Spring Pins
- Drive Chain Alignment

## FIELD CHECK SEED POPULATION

1. Tie up one or more sets of closing wheels by running a chain or rubber tarp strap between the hopper support panel and closing wheels. It may be necessary to decrease closing wheel arm spring tension.

Chain, rubber tarp strap, or similar.

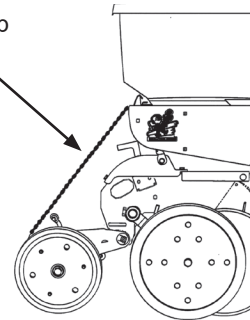

2. Plant a short distance and check to see if seed is visible in the seed trench. Adjust planting depth to a shallower setting if seed is not visible and recheck.

Planting depth adjustment handle

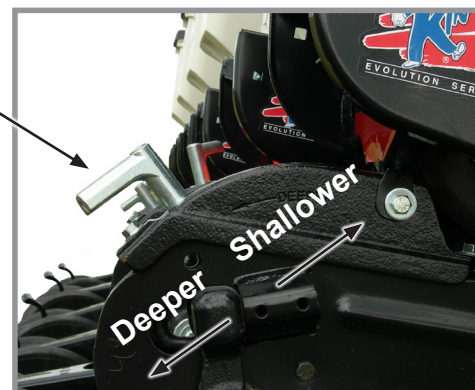

Planting depth adjustment

3. Measure  $\frac{1}{1000}$  of a hectare. See chart for correct distance for row width being planted. For example, if planting 70 cm rows  $\frac{1}{1000}$  of a hectare would be 14.28 meters.

**$\frac{1}{1000}$  Hectare Seed Population Count Row Width/Distance**

Row Width	35 cm	70 cm
Distance	28.56 m	14.28 m

**NOTE: Seeds may bounce or roll when planting with closing wheels raised and planting depth set shallow affecting seed spacing accuracy.**

4. Count seeds in measured distance.
5. Multiply number of seeds placed in  $\frac{1}{1000}$  of a hectare by 1000. This gives total population.

EXAMPLE: 70 cm row spacing 14.28 meters equals  $\frac{1}{1000}$  hectare.

75 seeds counted x 1000 = 75,000 seeds per hectare

Seed count can be affected by drive wheel and seed meter drive ratio, tire pressure, and/or seed meter malfunction.

1. If seed check shows average distance between seeds in centimeters is significantly different than seed rate chart indicates, first check drive ratio between drive wheel and seed meter. Check drive wheel air pressure, check for incorrect sprocket(s) in driveline and check drive and driven sprockets on transmission(s) for proper selection.
2. Check for seed meter malfunction. "Seed Meter (Vacuum)" on page 7-6.

**FIELD CHECK GRANULAR CHEMICAL APPLICATION**

Temperature, humidity, speed, ground conditions, flowability of different material, or meter obstructions can affect granular chemical rate of delivery.

 <b>WARNING</b>	<p><b>Agricultural chemicals can cause death or serious injury to persons, animals, and plants or seriously damage soil, equipment, or property. Read and follow all chemical and equipment manufacturers labels and instructions.</b></p>
--	--

Perform a field check to determine application rates.

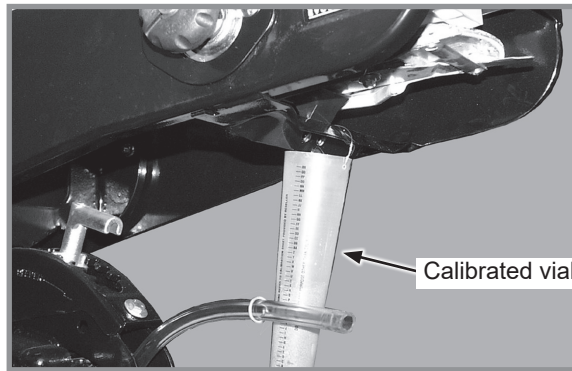

**Granular chemical field check**

1. Fill insecticide and/or herbicide hoppers.
2. Attach a calibrated vial to each granular chemical meter.

**NOTE: Disengage clutch to avoid dropping seed during test.**

3. Lower planter and drive 400 meters at planting speed.
4. Weigh chemical in grams caught in one vial.
5. Multiply that amount by factor shown to determine kilos per hectare.

Kilograms Per Hectare	
Row Width	Factor
70 cm	0.0357

EXAMPLE: You are planting 70 cm rows. You have planted for 400 meters at desired planting speed. You caught 337 grams of chemical in one vial. 337 grams times 0.0357 equals 12 kilograms per hectare.

**NOTE: Check calibration of all rows.**

**METERING GATE**

Use metering gate setting as a starting point for distributing insecticide or herbicide. Charts are based on 8 km/h planting speed. Use a higher gate setting for speeds faster than 8 km/h and a lower setting for speeds slower than 8 km/h.



## WATER TANK

The water tank is to only be filled with clean water or preferably potable water (water meeting local standards for drinking). The tank holds 15 L of water. Be sure to check for regulations pertaining to this use. Tank should be filled with new water at the beginning of each planting season and drained at the end of each planting season.

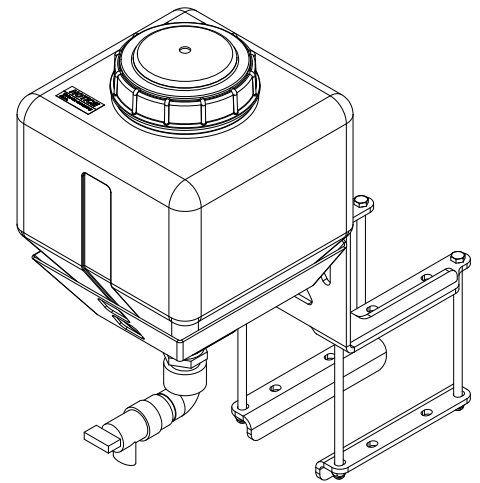

### NOTICE

**Drain tank if environmental conditions are 0° Celsius or below to prevent tank from cracking.**

The water tank is to be used in the event of an accidental exposure to chemical. Chemicals are supplied with Material Safety Data Sheets (MSDS) that provide full information about the chemical, its effects on exposure, and first aid needs in the event of an emergency. Keep your MSDS file up-to-date and available for first responders in case of emergency.

If the water tank is used seek medical assistance immediately for further treatment.

**This page left blank intentionally.**

## PLANTING DEPTH

Planting depth is maintained by adjustable row unit gauge wheels. Depth adjustment range is approximately 1.2 cm to 8.9 cm.

1. Raise planter to remove weight from wheels.
2. Push down on depth adjustment handle and reposition it forward to decrease or rearward to increase planting depth. Initially adjust all units to the same setting.
3. Lower planter and check operation and planting depth of all row units. Readjust individual rows as needed for uniform operation.



Planting depth adjustment

## “V” CLOSING WHEEL ADJUSTMENT (RUBBER OR CAST IRON)

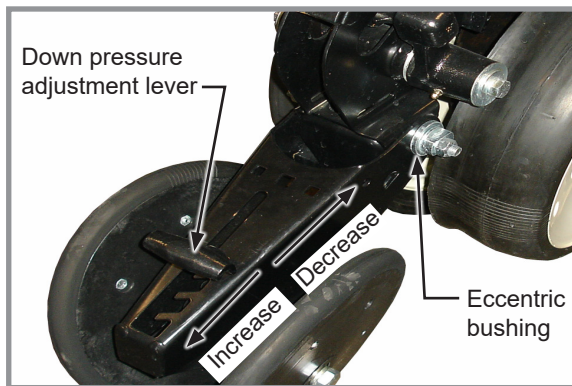

“V” Closing wheel adjustments

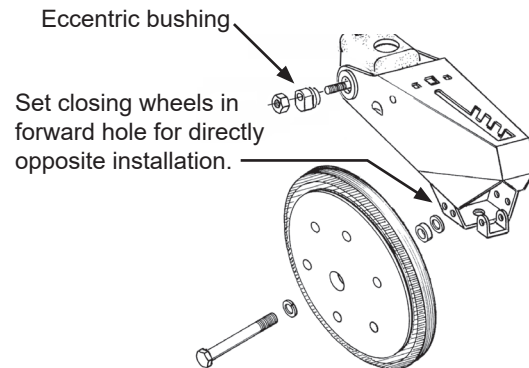

“V” closing wheels should have enough down pressure to close the seed trench and ensure good soil to seed contact. Move 5-position quick adjustable down force lever on the top of closing wheel arm to the rear to increase closing wheel spring pressure. Move lever forward to decrease pressure. Adjust all row units to a similar setting. Light soil usually requires less down force at average depth (approximately 5 cm) while heavy soil requires increased down force.

Eccentric bushings in the wheel arm stop allow for lateral adjustment of the “V” closing wheel assembly. Use a  $\frac{3}{4}$ " wrench to loosen hardware attaching closing wheel arm to wheel arm stop. Use another  $\frac{3}{4}$ " wrench to turn eccentric bushings until **closing wheels are aligned with seed trench**. Tighten hardware.

Closing wheels can be installed “offset” (to improve residue flow) or “directly” opposite. Use forward installation holes if set “directly” opposite.

**ROW UNIT EXTENSION BRACKETS**

Row unit extension brackets extend row units rearward 4" (10.1 cm) to provide clearance for coulters mounted residue wheels and HD single disc fertilizer openers.

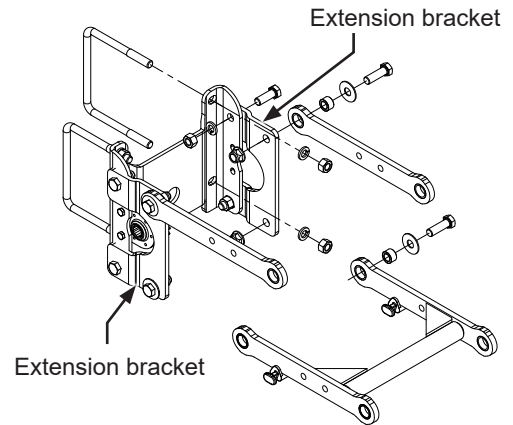

**Row unit extension brackets**

**SEED HOPPERS**

Vacuum seed hopper has a capacity of 62 L.

Use clean seed and make certain there are no foreign objects inside when filling seed hopper. **Replace hopper lids after hoppers are filled to prevent accumulation of dust or dirt in seed meter which can cause premature wear.**

Periodically empty hoppers completely to remove any foreign objects and to ensure proper seed meter operation.

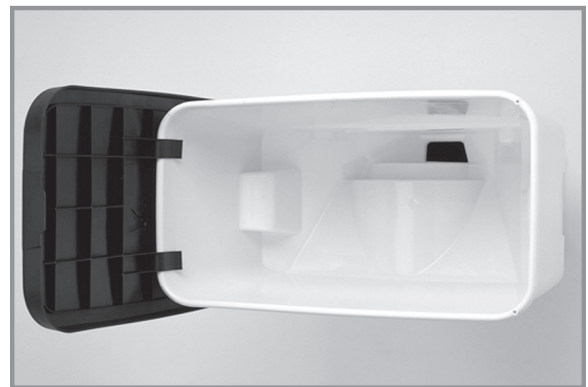

**Seed Hopper**

Disengage meter drive and hopper latch and lift hopper off hopper support. See "Seed Meter Drive Release".

**SEED METER DRIVE RELEASE**

A clutch release mechanism disengages seed meter drive from seed meter to remove seed hopper. Disconnecting drive allows operator to check granular chemical application rates without dropping seed. It also allows one or more rows to be disconnected when finishing fields.

Turn knob ¼ turn counterclockwise to disengage or ¼ turn clockwise to engage.

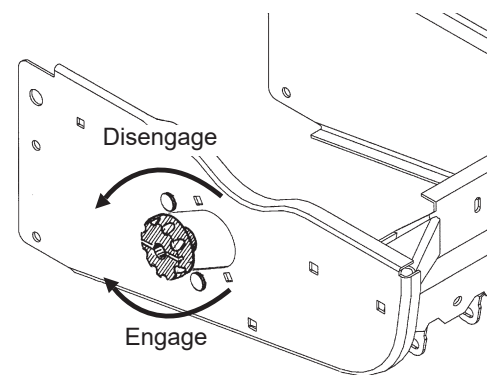

**Seed meter drive release**

### ROW UNIT CHAIN ROUTING

Row unit drive chains must be properly tensioned and aligned for proper operation and to minimize wear.

Inspect and replace weak, worn or broken springs, idlers, and idler bushings.

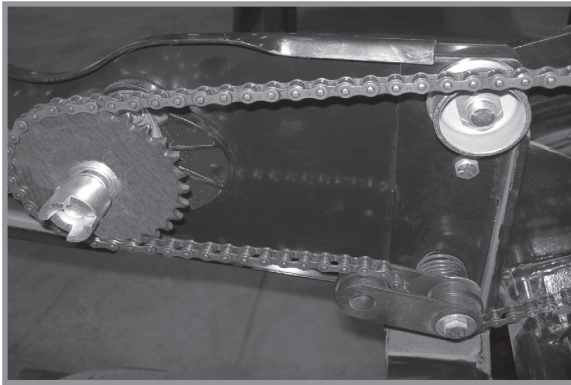

Vacuum pull row unit meter drive

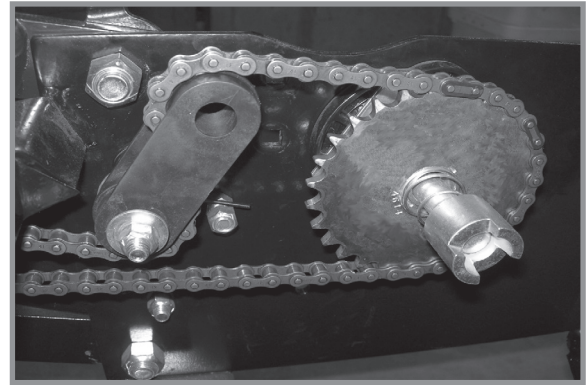

Vacuum push row unit meter drive

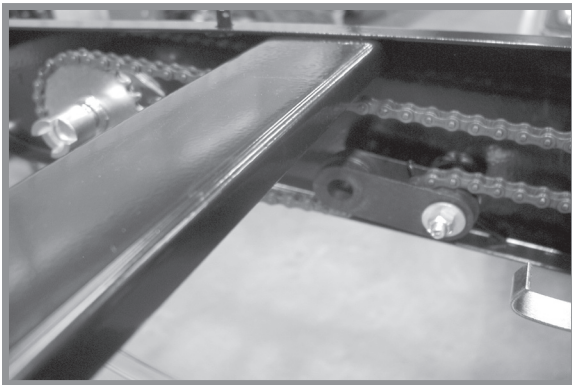

Row unit granular chemical drive

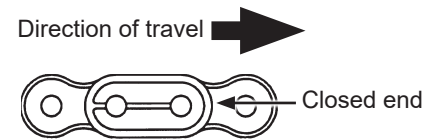

**NOTE: Install connector link with closed end facing direction of travel.**

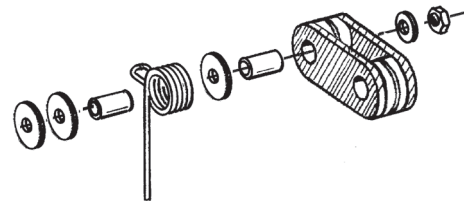

**NOTE: Reverse idler when worn on one side for extended use.**

**QUICK ADJUSTABLE DOWN FORCE SPRINGS OPTION**

Quick adjustable down force springs increase penetration in hard soil and keep row unit from bouncing in rough field conditions. Two springs per row, one on each side parallel arms, are used unless equipped with row unit mounted no till coulters. Four springs per row are used with row unit mounted no till coulters.

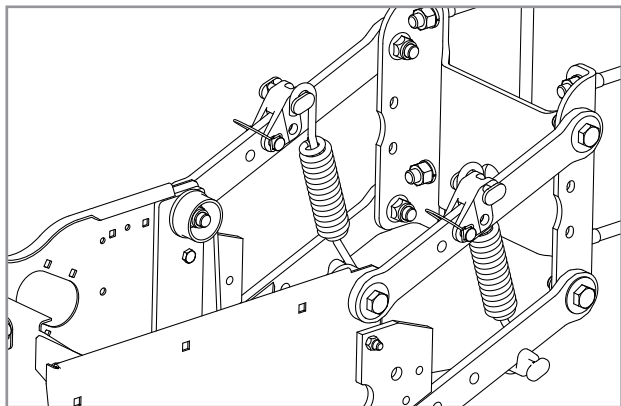

**Two Springs Per Row (Dual)**

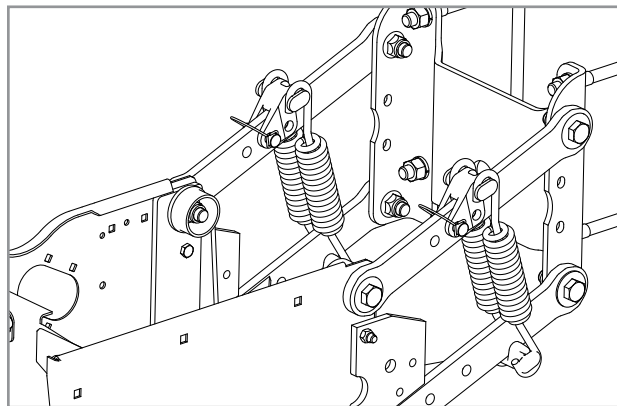

**Four Springs Per Row (Quad)  
(Row Unit Mounted No Till Coulters Only)**

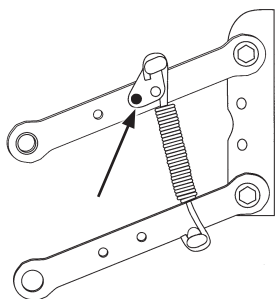

**Position 1 (Least)**

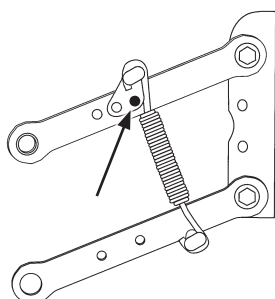

**Position 2**

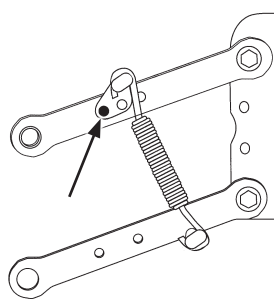

**Position 3**

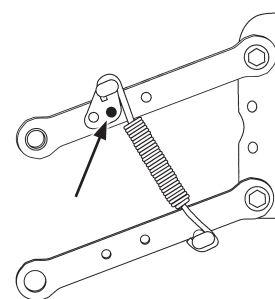

**Position 4 (Most)**

There are four positions to set down pressure spring tension.

**NOTICE**

Springs must be installed with open side of spring hooks toward seed hoppers to prevent binding on spring mount adjustment pins.

1. Raise planter and remove spring mount pin at top of spring.
2. Slide mount to desired position and install pin.

**NOTE: Adjust springs for field conditions. Too much down pressure in hard field conditions can cause row units to lift planter and keep drive wheels from making contact. Too much down pressure in soft field**

Heavy Duty Spring Down Force Pressure*		
	2 Springs	4 Springs
Position	Heavy Duty P/N: D21337	Heavy Duty P/N: D21337
1	43 lb (19.5 kg)	80 lb (36.3 kg)
2	86 lb (39.0 kg)	144 lb (65.3 kg)
3	167 lb (75.7 kg)	307 lb (139.3 kg)
4	249 lb (113.0 kg)	470 lb (213.2 kg)

\*Pressure does not include weight of row unit, seed, or options.

## PNEUMATIC DOWN PRESSURE PACKAGE OPTION

Row unit down pressure can be adjusted on-the-go as field conditions change with pneumatic down pressure option. A cab-mounted control box adjusts pressure (Older models may have a digital readout). A planter-mounted 12 VDC air compressor with 3 gallon capacity air tank supplies air for the down pressure system.

Packages include upper and lower air spring mounting castings for pull row units (front and rear air spring mounting castings for push row units), 150 psi rated air springs,  $\frac{3}{8}$ " O.D. nylon hoses, dual solenoid air valve and stainless steel, 160 psi, 2" liquid-filled gauge and planter wiring harness.

Pneumatic down pressure row unit extension brackets are required in some applications.

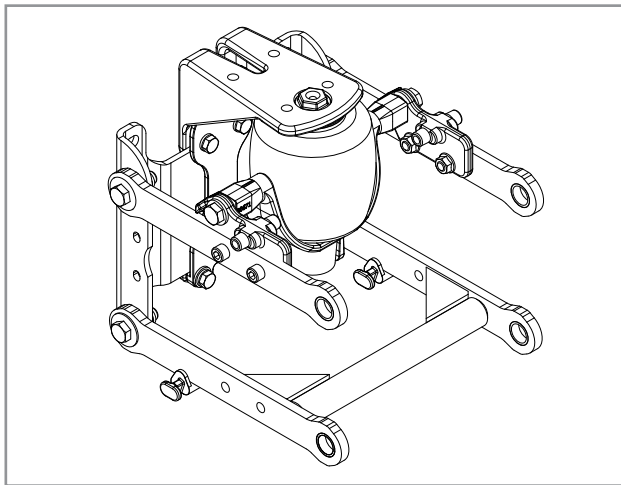

**Pull Row Unit Air Spring**

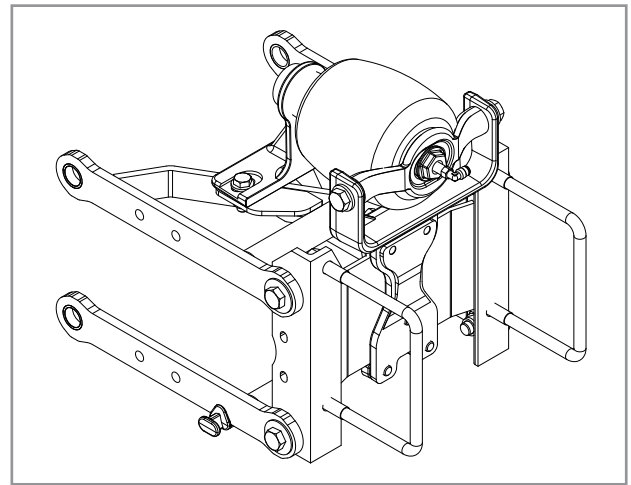

**Push Row Unit Air Spring**

**NOTE:** If additional down pressure is needed with the Pneumatic Down Pressure Package, assist springs are available through your Kinze dealer. One spring is installed on the outer side of the parallel arms on each side of the row unit as shown below.

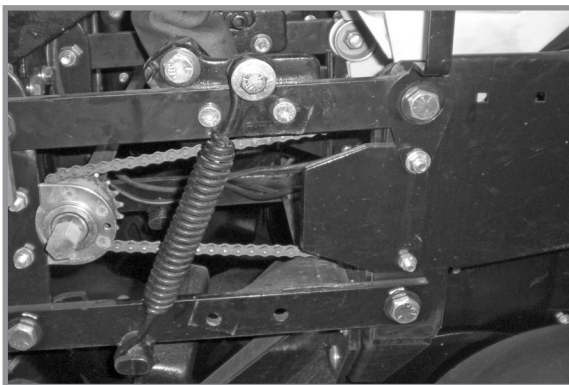

**Pull row unit assist springs**



**Push row unit assist springs**

## FIELD OPERATION

**NOTE: Adjust down pressure with planter lowered and row openers in ground for most accurate adjustment. Pressure can be adjusted from tractor using control console, or at planter using manual control valves on compressor assembly.**



Control console

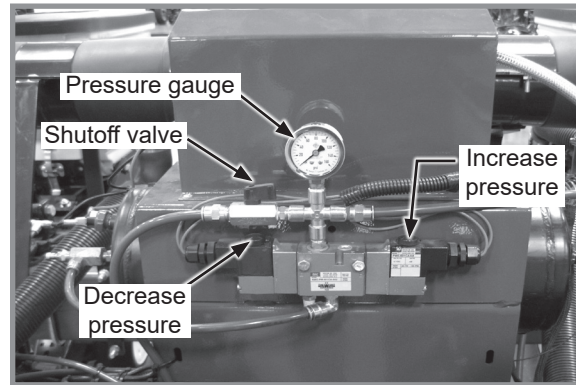

Air compressor assembly controls

## ADJUST DOWN PRESSURE FROM CAB

Push toggle switch left to increase or right to decrease pressure.

## ADJUST DOWN PRESSURE AT PLANTER

Push and hold decrease or increase button on compressor assembly to decrease or increase pressure.

**NOTE: Value on the air pressure gauge is NOT down pressure force. Multiply air pressure (psi) by four (4) to calculate down pressure.**

## LOCK UP PUSH ROW UNITS EQUIPPED WITH PNEUMATIC DOWN PRESSURE SPRINGS

1. Disconnect electric power supply to compressor.
2. Press and hold button on solenoid until pressure gauge reads zero.
3. Lock up units. See "Split Row Push Unit Lockup" for instructions.
4. Turn shutoff valve handle perpendicular to valve body to turn off air supply to push row units.

**NOTE: If control console is ON and pneumatic down force is not set to zero, compressor will start when electric power supply is reconnected.**

5. Reconnect electric power supply to compressor.

**Refer to M0288 - Kinze Blue Vantage Operator's Manual for pressure adjustment with Blue Vantage.**





$$\text{PSI} \times 4 \times 0.45 = \downarrow \text{kg}$$

$$\text{MAX.} \sim 218 \text{ kg}$$

PDP Down Force Calculation

## TRUE DEPTH OPTION

True Depth provides on demand row by row hydraulic row unit down force ranging from ~45 kg. up force to ~270 kg. down force at 2350 psi. The system includes a 7" in cab standalone touchscreen display with antiglare screen protector and RAM mount, electronic control modules, harnesses, gauge wheel sensors, hydraulic cylinders, upper and lower cylinder mounts, and valves. See M0288 - Kinze Blue Vantage Operator's Manual.

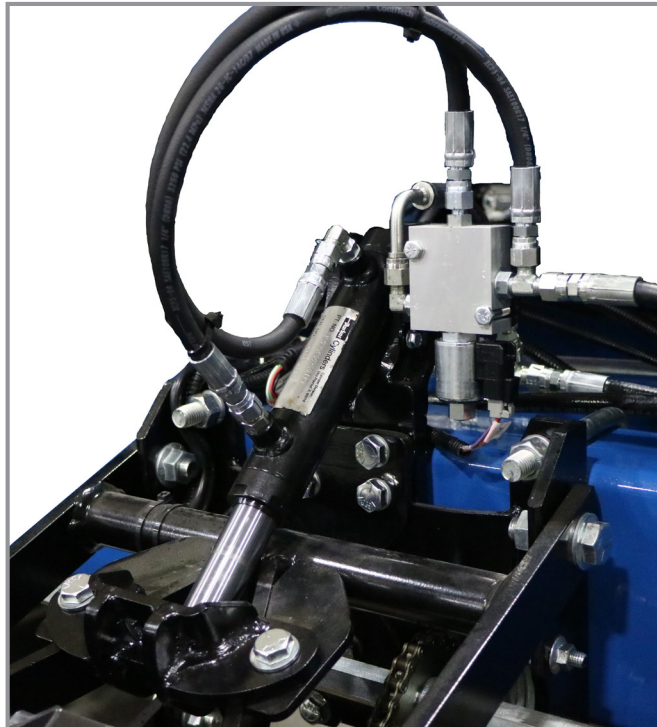

## SPLIT ROW PUSH ROW UNIT CLUTCH SPROCKET

Push row unit clutch sprocket disengages Split Row drive from push row unit drill shaft when only pull row units are used.

### DISENGAGE

Rotate knurled collar  $\frac{1}{4}$  turn. Rock drill shaft slightly using a  $\frac{7}{8}$ " wrench to take pressure off of spring loaded pins in clutch to allow pins to "pop" out, disengaging drive.

### ENGAGE

Rotate knurled collar  $\frac{1}{4}$  turn and turn drill shaft with a  $\frac{7}{8}$ " wrench until drive pins engage drive sprocket.

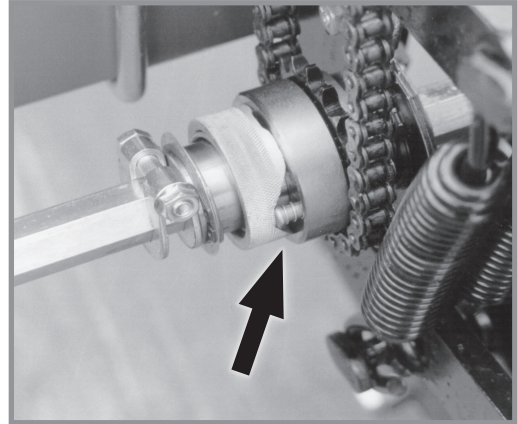

Split Row clutch sprocket

## SPLIT ROW PUSH ROW UNIT VACUUM HOSE SHUTOFF

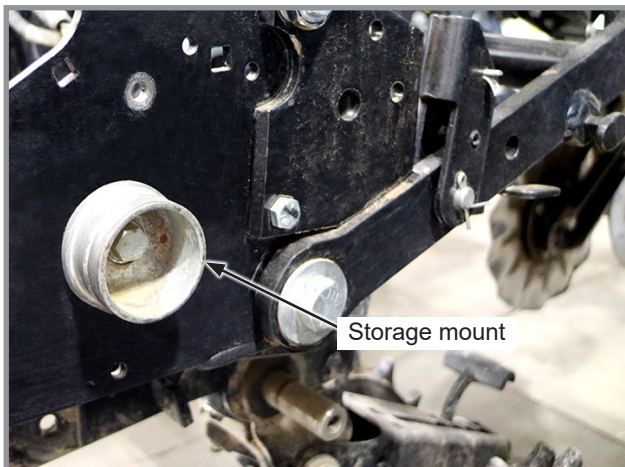



Split Row vacuum hose shutoff

When push row units are not used, move row unit end of 1-1/2" (3.8 cm) vacuum hose on each push row unit to storage mount located on side of shank.

### SPLIT ROW LOCKUPS

Split row lockups are designed to allow the push row units to be locked in the raised position.

 <b>CAUTION</b>	<p>Improper lifting of row units can cause serious injury. An empty row unit requires minimum 84 lb (38.1 kg) lift. Set down pressure springs to minimum, lower planter to ground, and empty seed hopper before attempting to lift with this lever.</p>
	

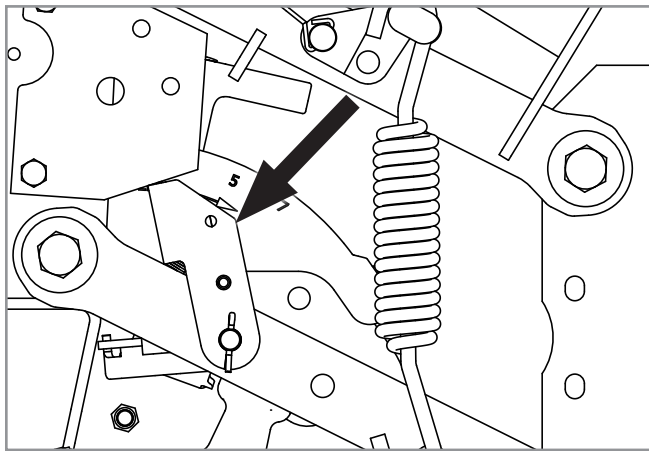

Push Row Unit Locked In Raised Position

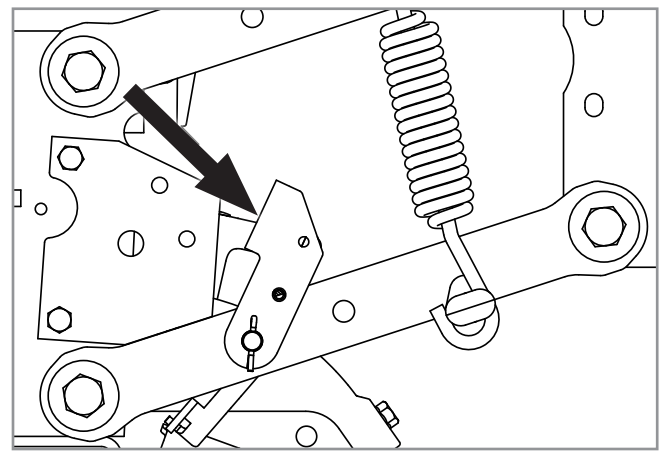

Lockup Released For Field Operation

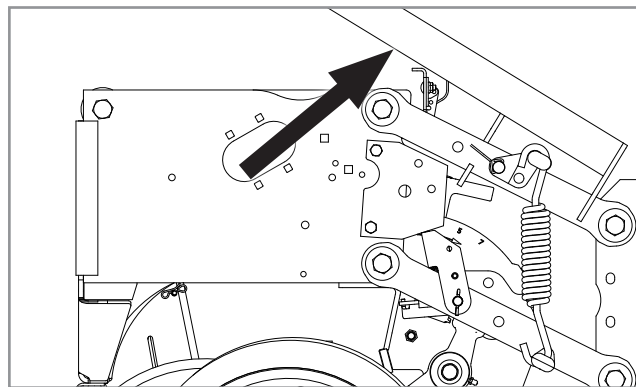

Lift lever positioned on push row unit

**To Lock Row Unit in Raised Position:**



1. Set row unit down pressure springs to minimum setting.
2. Lower the planter to the planting position.
3. Empty seed hoppers.

**Note: If planter is equipped with True Depth, enable Lift Assist Mode with the Blue Vantage Display. See M0288 - Kinze Blue Vantage Manual.**

 <b>WARNING</b>	Turning Lift Assist on or off may cause the planter to move or row units to fall causing injury or death.
--	---

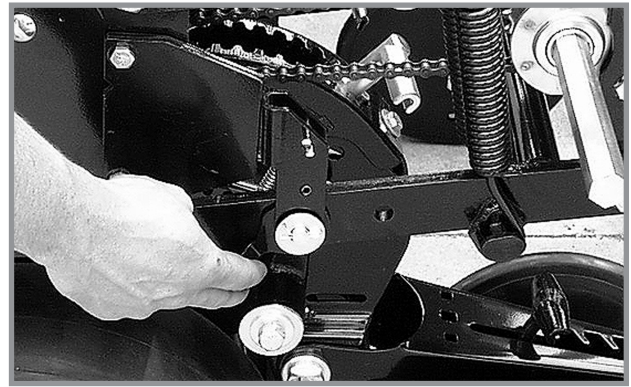
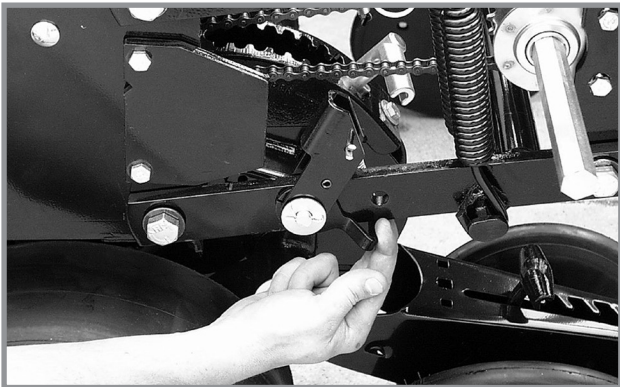
4. On each push row unit lockup, flip the spring tab forward.



 <b>DANGER</b>	Uncontrolled movement of equipment can cause loss of control and could result in death, serious injury, or damage to property and equipment. Keep clear of row unit while lowering it to the ground.
	

5. Using the lift lever, raise the push row unit to allow the spring loaded lockups to snap into locked position under the row unit stops.

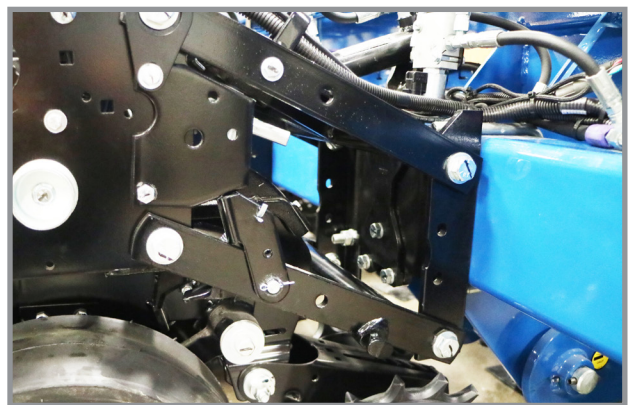

6. Ensure that the row unit is lowered onto the stops.

7. Repeat Steps 4 through 6 on remaining push row units.

**To Release Row Unit to Planting Position:**

1. Lower the planter to the planting position.

**Note: If planter is equipped with True Depth, enable Lift Assist Mode with the Blue Vantage Display. See M0288 - Kinze Blue Vantage Manual, Page 18.**

**WARNING**

Turning Lift Assist on or off may cause the planter to move or row units to fall causing injury or death. Please ensure that all row units are pushed down before exiting Lift Assist mode.

2. On each push row unit lockup, flip the spring tab rearward.

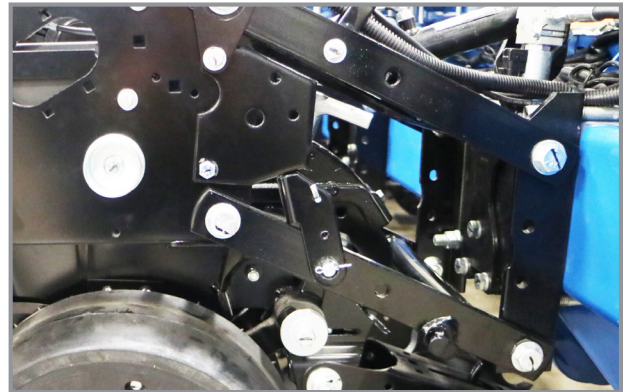
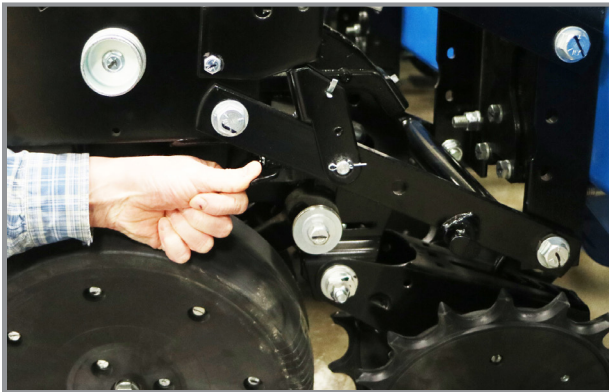











**DANGER**

Uncontrolled movement of equipment can cause loss of control and could result in death, serious injury, or damage to property and equipment. Keep clear of row unit while lowering it to the ground.

3. Using the lift lever, raise the push row unit to allow the spring loaded lockups to snap out of locked position. Lower row unit to the ground.
4. Ensure that the row unit is lowered all the way to the ground.



**VACUUM SETTINGS**

Crop		**Seed Disc Kit	Seed Disc Part No.	Ejector Wheel (Color)	Cells	Seed Size Range	Singulator Zone Setting	Vacuum Setting Inches of Water (cm)	Lubricant
	Corn ‡ Large Sweet Corn	G11043X	B1219 (Light Blue)	1 row 5 punches (Light Blue)	40	35-70 lbs/80k (2500-5000 seeds/kg)	2	18-20 (46-51)	Graphite* Talc*
	Soybean	G11047X	B1232 (Black)	2 rows 6 punches (Black)	120	2200-4000 seeds/lb (4850-8820 seeds/kg)	0	10-14 (25-36)	Graphite* Talc*
	Sugar Beet	G11045X	B1229 (Dark Orange)	1 row 6 punches (Dark Orange)	60	Pelletized	2	15 (38)	Graphite*
	Milo	G11045X	B1229 (Dark Orange)	1 row 6 punches (Dark Orange)	60	10,000-20,000 seeds/lb (22000-44000 seeds/kg)	2	15 (38)	Graphite* Talc*
	Sunflower ‡ Small Sweet Corn	G11044X	B1230 (Gray)	1 row 5 punches (Gray)	40	Oil seeds #2, 3, 4	2	12-18 (30-46)	Graphite* Talc*
	Sunflower	G11044X	B1230 (Gray)	1 row 5 punches (Gray)	40	Oil seeds #5	2	5-8 (13-20)	Graphite* Talc*
	Specialty Disc 1	G11105X	B1233 (Green)	1 row 6 punches (Green)	60	Cotton	2	15-20 (38-51)	Graphite* Talc as needed*
	Specialty Disc 2	G11106X	B1235 (Brown)	1 row 6 punches (Green)	60	Black turtle & navy edible beans	2	15-20 (38-51)	Graphite* Talc as needed*
	Specialty Disc 3	G11107X	B1234 (Dark Blue)	1 row 6 punches (Green)	60	Pinto & Great Northern edible beans & low-rate soybean	2	15-20 (38-51)	Graphite* Talc as needed*
	Rapeseed	G11046X	B1239 (Dark Gray)	1 row 10 punches (Dark Gray)	83	See Rapeseed Planting Section	0	See Rapeseed Planting Section	Kinze Brand Graphite Only
	Wheat Disc	G11332X	10783001 (Red)	3 rows 9 punches (Red)	231	17,600-44,000 seeds/kg	§N/A	15-24 (38-61)	Graphite* Talc as needed*
	Wheat Disc***	G11042X	B1236 (Purple)	Brush type	54	N/A Volumetric	0	6-16 (15-41)	Graphite* Talc as needed*

Install selected seed disc. Position vacuum cover on meter by aligning keyhole slots over bolt heads. Push cover on meter and turn counterclockwise to lock in place.

\*For More information on application rate, see Additives section.

\*\*Includes seed disc, ejector wheel, and spring.

\*\*\*Sold as a repair part only.

‡Conventional hoppers only, not applicable with bulk fill.

§Wheat disc wiper must be installed, refer to ["Wheat Disc Wiper Installation" on page 3-14](#)

**NOTE:** See ["Field Check Seed Population" on page 2-46](#) for more information. Always field check seed population to ensure planting rates are correct.

**NOTE:** Singulator settings are marked from 0 - 3.

**NOTE:** Mixing seed sizes and shapes affects meter performance. Use consistent seed size and shape.

**NOTE:** Use 1 tablespoon powdered graphite with standard each hopper fill of seed. Seed treatment, foreign material, dirt or seed chaff may cause gradual reduction of seed disc fill (population). See "Additives" pages for more information.

**NOTE:** Excessive seed treatment, humidity, and light-weight seed can affect meter performance. Use ½ cup of talc with each standard hopper fill of seed and mix thoroughly to coat all seeds and adjust rates as needed. Use of talc aids seed flow into meter, singulation, and disc seed drop.

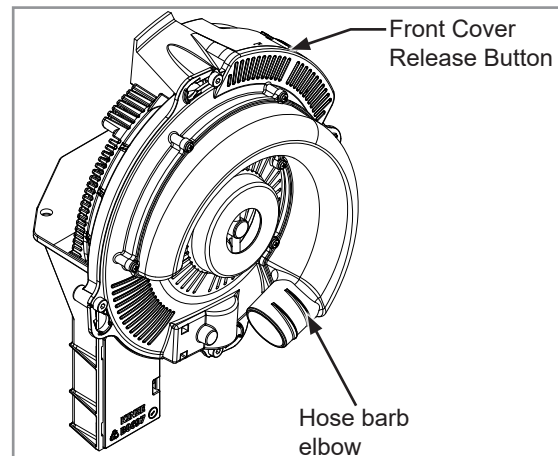
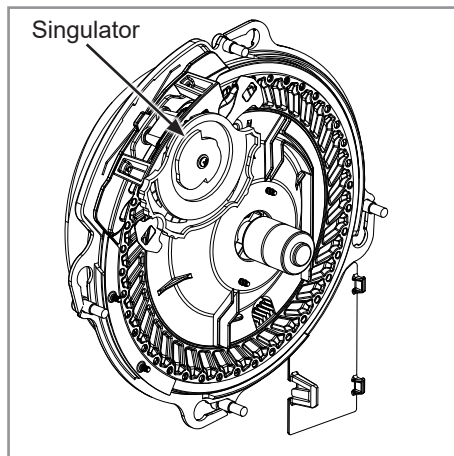

**NOTE:** Foreign material in seed disc orifices, such as seed chips, hulls, stems, etc., may affect seed delivery. Clean seed ensures accurate seed metering from vacuum seed meter. Remove Seed discs daily to check for buildup of foreign material in seed disc orifices.

Air inlet screens allow air to enter system and aids in keeping field residue or other foreign material out of meter.

See ["Vacuum Seed Meter Maintenance" on page 6-13](#) and ["Preparation for Storage" on page 6-35](#) in Lubrication and Maintenance section for more information.

## WHEAT DISC WIPER INSTALLATION

1. Disengage seed drive and remove seed hopper and meter.
2. Rotate seed disc hub clockwise to unlock and remove seed disc.
3. Remove singulator.
4. Install wheat disc wiper in place of singulator.
5. Reinstall seed disc.

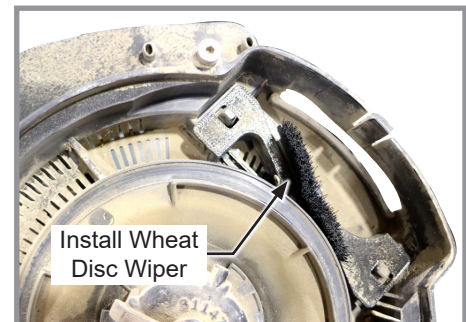
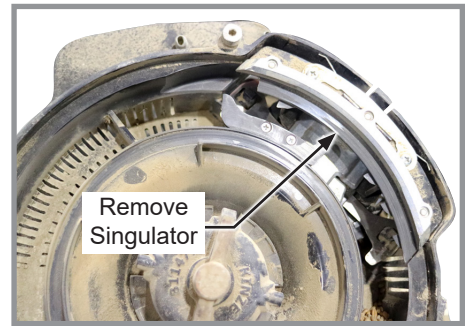



**NOTE: Damaged seed or seed containing foreign material will cause plugging of seed disc orifices and require more frequent seed meter cleanout to prevent underplanting.**

#### Wheel-Type Ejectors

Wheel-type ejectors expel seed remnants from seed disc orifices. These ejectors are disc specific and colored coded to match disc.

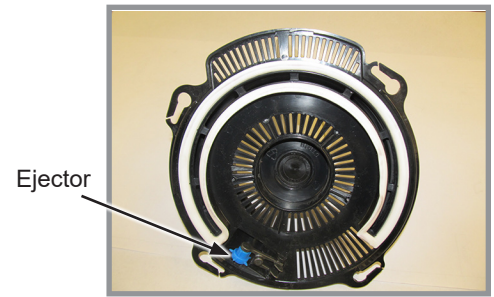

### NOTICE

Replace hopper or tank lids after filling to prevent accumulation of dust or dirt in seed meter resulting in premature wear.

**NOTE: Seed size, seed shape, seed treatments, travel speed, and planting rate affect meter performance.**

1. Select seed disc and ejector to match crop and population.

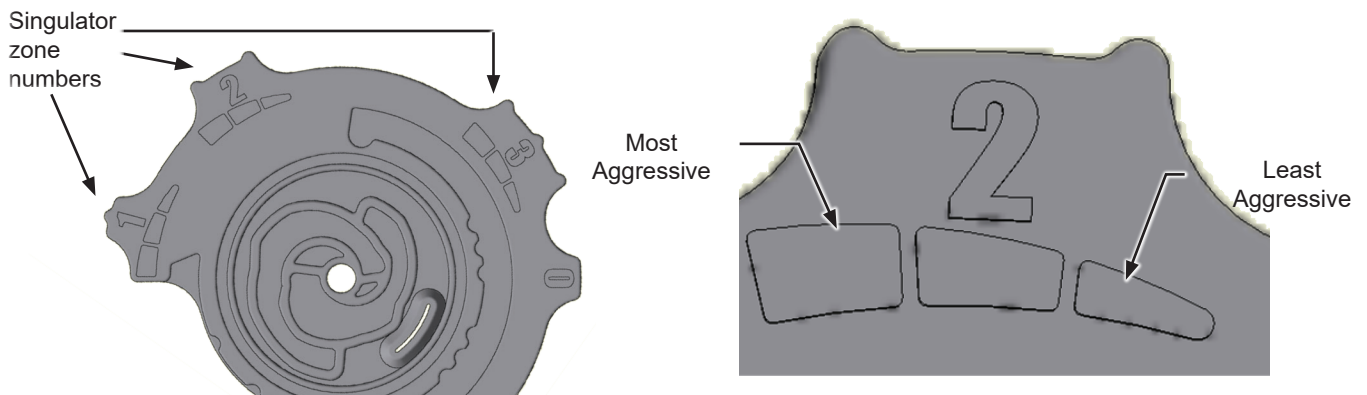

**Singulator Adjustment Wheel**

2. Adjust singulator wheel to initial setting. Seed size, seed shape, seed treatments, travel speed and planting rate all affect meter performance.
3. With vacuum fan running, lower planter to planting position and drive forward a short distance to load seed into seed disc cells.
4. Adjust vacuum level to initial setting according to tables on page.

**NOTE: Vacuum reading will be much lower when seed disc cells are empty. Load all seed cells before setting vacuum level.**

**NOTE: Operate vacuum fan 3-5 minutes to bring oil up to normal operating temperature prior to making final vacuum level adjustment.**

4. Adjust vacuum level to initial setting according to tables on page.

**NOTE: Vacuum reading will be much lower when seed disc cells are empty. Load all seed cells before setting vacuum level.**

**NOTE: Operate vacuum fan 3-5 minutes to bring oil up to normal operating temperature prior to making final vacuum level adjustment.**

**RAPESEED PLANTING SECTION**

<b>NOTICE</b>	<p>When used with rapeseed, some seed will be lost through the air dissipator screen. Proper lubrication and quality seed is essential for proper machine operation.</p>
---------------	--

**MONITOR SETTINGS**

<b>KPM III</b>	
Meter Type:	Vacuum
Meter Sprocket:	28 Tooth
Crop Type:	Other Small Seed
Seeds Per Rev:	83
Seed Size:	1
Split Rows	Enable

See KPM III Electronic Seed Monitor Operator Manual for more details.

**NOTE** Set sensitivity value to 1 for Ag Leader InCommand and Integra monitors. See Monitor Operator manual for more information.

**NOTE:** Because of small seed size and high seeding populations, it is possible in certain planting conditions that not all seeds will be detected by the row unit seed sensor. So, it is possible KPM III and Ag Leader InCommand or Integra monitors might not show correct seeding accuracy. Monitor planting accuracy alarm may be required to be adjusted to lower accuracy (or muted) due to false accuracy alarms. Frequent field checks are recommended.

**VACUUM SETTINGS**

Due to rapeseed size and weight variations planting settings may vary. Testing with a Kinze T4000 test stand is recommended to verify vacuum level setting and to achieve best planting accuracy. See your Kinze dealer for testing.

Set desired vacuum to value found during testing (recommended) or use preliminary values provided in chart below.

If testing is unavailable measure 20 - 50 seed samples and find average seed diameter (largest - width/length/height seed dimension).

Target Speed (km/h)	Target Population	Target Vacuum (inches (cm) of water)		
		Small Seed Diameter Range: 1.2 - 2.0mm (Average: 1.6mm)	Medium Seed Diameter Range: 1.5-2.5mm (Average: 2.0mm)	Large Seed Diameter Range: 1.6-3.1mm (Average: 2.6mm)
8	350000	4 (10)	4 (10)	6 (15)
8	500000	4 (10)	6 (15)	8 (20)
8	650000	4 (10)	8 (20)	12 (30)
8	800000	4 (10)	12 (30)	16 (40)
10	350000	4 (10)	6 (15)	8 (20)
10	500000	4 (10)	8 (20)	12 (30)
10	650000	4 (10)	10 (25)	14 (35)
10	800000	6 (15)	12 (30)	16 (40)

---

## ADDITIVES

### Rapeseed

It is essential to use graphite to neutralize electrostatic rapeseed properties.

Mix rapeseed with Kinze graphite thoroughly in a closed container. Keep mixing until all seed becomes evenly coated. Excessive graphite will stay on the bottom of container. It is recommended to prepare an even amount of seed-graphite mix for each hopper separately. This will help to monitor each row performance while planting.

Use approximately 1Tbs (15ml) of graphite per 3-4L of seed.

**NOTE: For best performance Kinze brand graphite MUST be used.**



## RATE CHARTS

For Rapeseed Rate Charts, See ["Rate Charts" on page 5-1](#) section of this manual.

**VACUUM METER INSULATION FOR RAPESEED PLANTING**

Additional insulating shims for Vacuum Meters are needed in order to successfully and efficiently plant rapeseed with Blue Drive equipped machines, as they prevent the seeds from getting crushed, thus clogging up the seed disc. The shims are obligatory on Blue Drive planters but provide a tangible benefit when used on Ground Contact Drive planters as well. The instructions below detail the process of shim insertion and removal, as well as washing of seed discs.

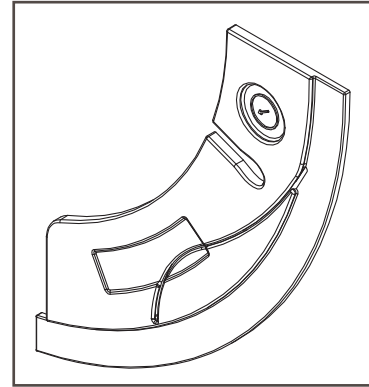

**Rapeseed Meter Insulation Shim**

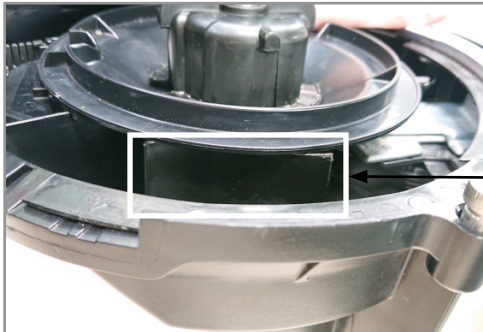

Place of the Shim on the Baffle

**Inserting the Insulation Shim:**

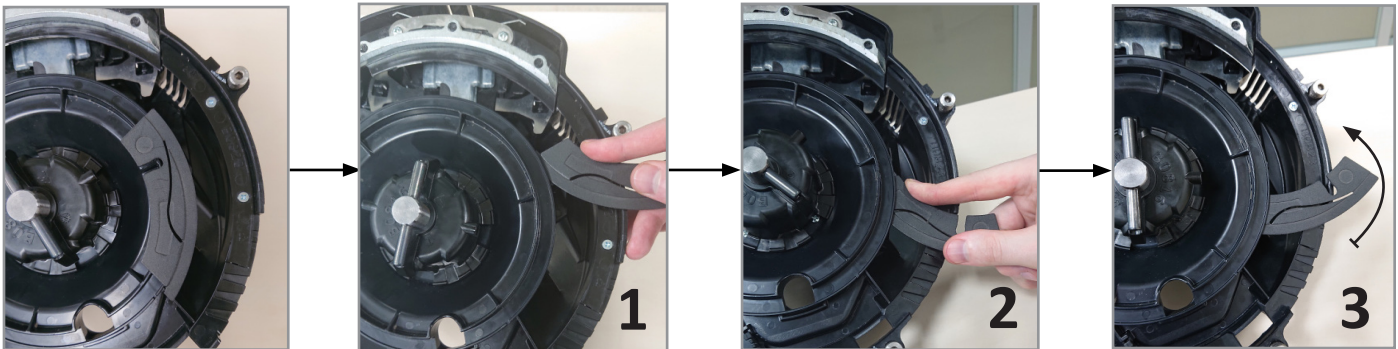

1. Begin inserting the Insulation Shim by sliding the tail end of it inside the gap indicated above, knife-like (img. 1).
2. Once initially inserted in the gap, rotate the Shim to the left by about 90° (img. 2 & 3).
3. Proceed to apply continual pressure while also maintaining the desired direction with your fingers until the shim is securely inserted (the longitudinal contoured gap in the shim is aligned with the contour of the baffle of the vacuum meter on which it sits, the shim clicks into place)(img. 4, 5 & 6).

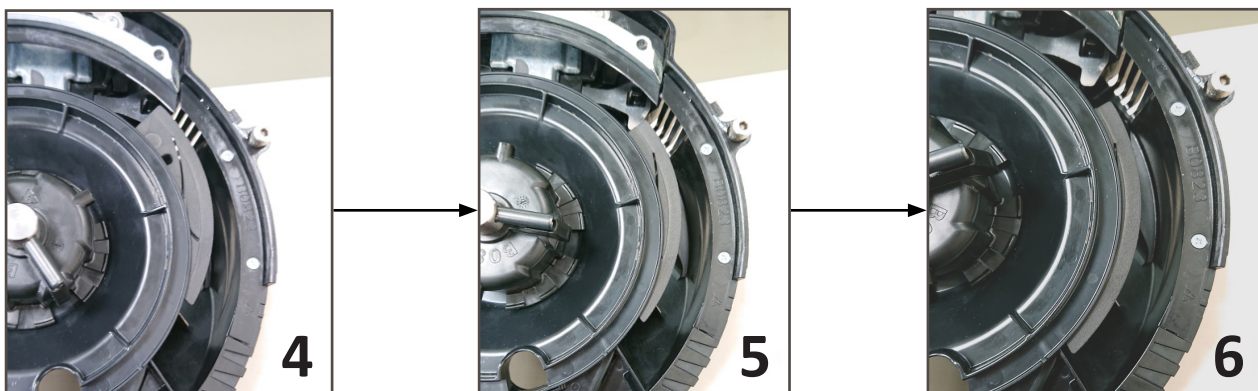

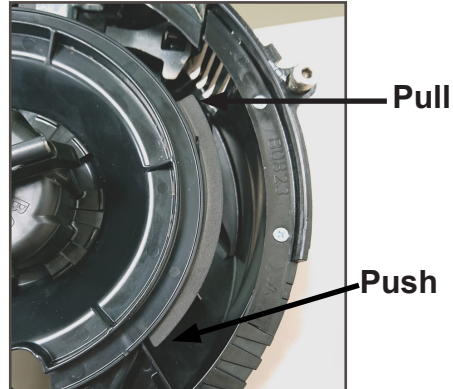
**Removing the Insulation Shim:**

To remove the Insulation Shim, push down with your fingers on one end, while pulling on another end (see image above).

**Washing Seed Discs:**

When planting Rapeseed, Seed Discs will periodically need to be scrubbed and washed with soap and water to remove the accumulated oils and debris, which prevent the disc from functioning optimally. Maintaining clean discs will ensure the best planting results.

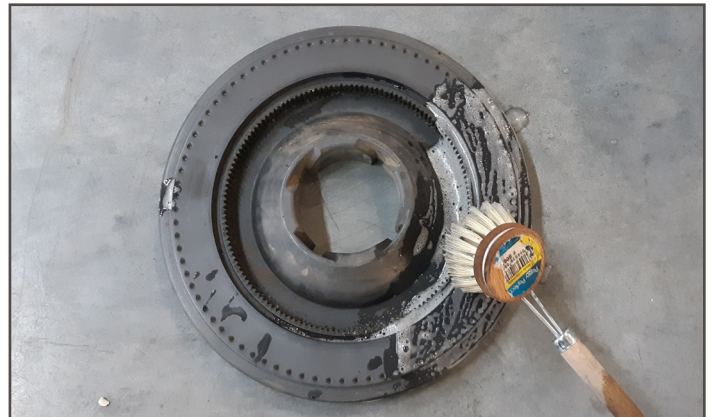

## SEED METER CLEANOUT

**NOTE: Use of damaged seed or seed containing foreign material will cause plugging of seed cell orifices and require more frequent seed meter cleanout to prevent underplanting.**

Thorough seed meter cleanout is important to maintain genetic purity.

1. Disengage seed drive and remove seed hopper and meter.
2. Dump seed from right rear corner of hopper into a container.
3. Lay hopper on its right side. Push release button and rotate seed meter vacuum cover clockwise to align keyhole slots with bolt heads. Lift off cover.
4. Rotate seed disc hub clockwise to unlock and remove seed disc.
5. Empty meter.
6. Thoroughly inspect meter to ensure all seed is removed.
7. Replace seed disc. Install vacuum cover.

## ADDITIVES

### GRAPHITE

The use of graphite is recommended to promote seed flow, provide lubrication for the seed meter and to help dissipate static charge buildup. Among the available dry seed lubricants graphite is the most effective and easiest to use and it requires no mechanical agitation

### CONVENTIONAL HOPPERS

Mix one tablespoon of **powdered graphite** with seed each time hoppers are filled. Regular graphite use prolongs life of the seed meter components, improves seed spacing, and may reduce buildup of seed treatments.

**NOTE: DO NOT apply graphite only in center of hopper. It will filter too quickly through the seed and not distribute as evenly as desired.**

Apply graphite around outer perimeter of hopper.

### BULK FILL TANKS

Mix 1 pound (~0,5 kg) bottle of powdered graphite each time the bulk seed hopper is filled. Graphite should be added in layers as the bulk seed hoppers are filled. Regular graphite use prolongs life of the seed meter components, improves seed spacing, and may reduce buildup of seed treatments.

**NOTE: Additional graphite may be required to retard buildup of seed treatments on meter components. More frequent cleaning of monitor seed tubes may be necessary due to use of additional graphite.**

Lubricant Application Rate	
<b>Graphite</b>	
Conventional Hoppers	1 Tbs. (~15 ml)/Hopper Fill
Bulk Fill Tan	1 Lb (~0,5 kg) Bottle/Tank
<b>80/20 Talc-Graphite</b>	
Conventional Hoppers	1/2 C (120 ml).**
Bulk Fill Tanks	8 Lbs (~4 kg)/Tank
**Must be evenly mixed during fill.	
<b>Talc</b>	
Conventional Hoppers	1/4" C. (~59 ml*)
Bulk Fill Tanks	4 Lbs (~2 kg)/Tank*
*Double amount of talc for sunflowers.	



Adding graphite to conventional hopper



Adding graphite bulk fill hopper

### 80/20 TALC-GRAPHITE

Talc-Graphite lubricant is to be used for treated seed, providing benefits of both talc and graphite. It absorbs moisture to prevent bridging, minimizes static electricity for improved seed flow, and lubricates seed and meters.

#### Conventional Hoppers

Mix ½ C. of 80/20 talc-graphite evenly with seed each time hoppers are filled. Regular graphite use prolongs life of the seed meter components, improves seed spacing, and may reduce buildup of seed treatments.

**NOTE: Talc-Graphite lubricant MUST be mixed evenly during fill.**

#### Bulk Fill Hoppers

Mix 8 lbs. of 80/20 talc-graphite each time the bulk seed hopper is filled. Regular graphite use prolongs life of the seed meter components, improves seed spacing, and may reduce buildup of seed treatments.

**NOTE: Talc-Graphite lubricant MUST be mixed evenly during fill.**

### TALC

**Talc seed lubricant** may be used as a drying agent in addition to graphite lubrication. The drying agent may improve seed release and/or **to retard buildup of seed treatments on meter components.**

1. Fill hopper ½ full of seed, add ¼ cup (conventional); 2 pounds (Bulk Fill) of talc and **mix thoroughly.**
2. Finish filling hopper, add another ¼ cup (conventional); 2 pounds (Bulk Fill) of talc and **mix thoroughly.**
3. Adjust rate of talc use as needed so all seeds are coated, while avoiding a buildup of talc in bottom of hopper.

Humid conditions and/or small sized seeds with extra seed treatment may require additional talc to maintain meter performance.

**NOTE: Liquid seed treatments or inoculants may create buildup on the seed disc or brushes. Check frequently for proper population and/or seed delivery when using any liquid seed treatment.**

Completely mix all treatments with seed following manufacturers' recommendations. Seed treatment dumped on top of seed after hopper is filled may not mix properly and cause seed bridging, reducing population or stopping meter from planting.

**ROW UNIT MOUNTED RESIDUE WHEEL**

Row unit mounted residue wheels are used on pull and push row units.

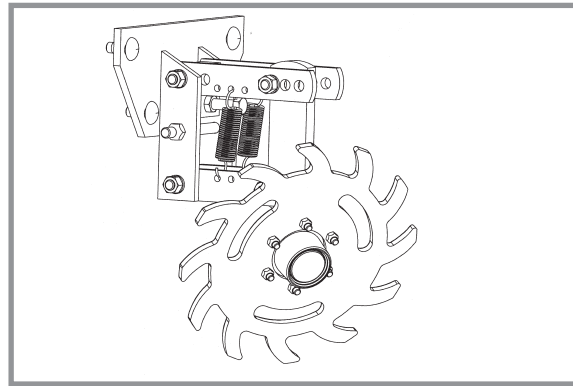

**Row Unit Mounted Residue Wheel**

Two adjustable springs on each residue wheel parallel links provide down force adjustment. Position 1 provides minimum down pressure and position 3 maximum down pressure.

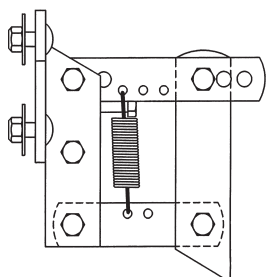

**Position 1 (Least)**

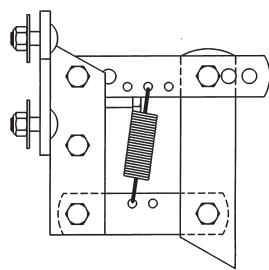

**Position 2**

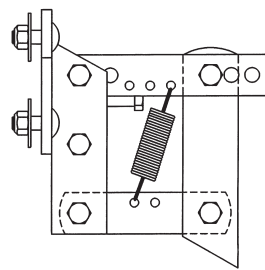

**Position 3 (Most)**

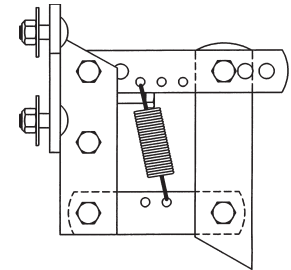

**Additional uplift or float**

Raise row unit and reposition springs to adjust down pressure.

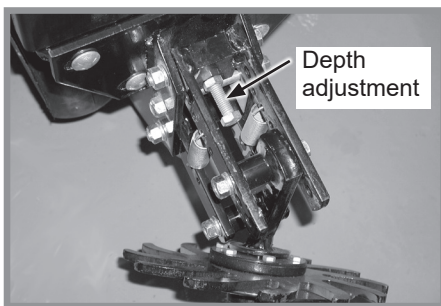

**Wheel depth adjustment**

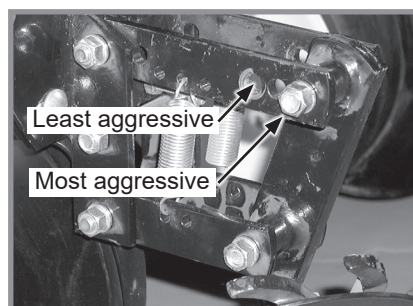

**Wheel angle adjustment**

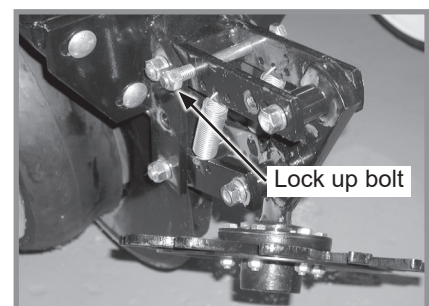

**Wheel lock up**

A full threaded bolt and jam nut located on the upper link sets maximum depth for loose soil conditions. Initial setting is 45 mm above row unit double disc opener depth.

Three holes in upper link adjust wheel angle. With wheel mount in most vertical position, using the rear hole in the upper link, the residue wheel is most aggressive. Moving wheel mount to a forward hole reduces aggressiveness of residue wheel for use in mulch till applications where soil is loose.

To lock residue wheel up, remove 1/2" x 5" lockup bolt, raise residue wheel and install bolt.



## ROW UNIT MOUNTED NO TILL COULTER

Row unit mounted no till coulters with 1" (25 mm) bubbled, 1" (25 mm) fluted (8 flutes) or ¾" (19 mm) fluted (13 flutes) blades may be used on pull row units and push row units (¾" fluted shown). Four quick adjustable down force springs are required per row when using row unit mounted no till coulters. See "Quick Adjustable Down Force Springs Options".

Align coulters to row unit double disc openers. Adjust by loosening four attaching bolts, moving coulters, and tightening four attaching bolts. Coulters can be adjusted to one of four ½" incremental settings in the forked arm. Initial location is the top hole.

Move blade as it wears to one of the three lower holes to maintain coulters at or slightly below opener discs. Adjust coulters below depth of double disc opener blades in very hard soil conditions such as compacted wheel tracks to improve opener penetration and cutting of surface residue.

Check operating depth by setting planter down on a level concrete floor and checking relationship between coulters and row unit opener blades. Make sure planter is level and coulters are square with planter frame and aligned with row unit disc opener.

**NOTE: Torque 5/8" spindle hardware to 163 Nm.**

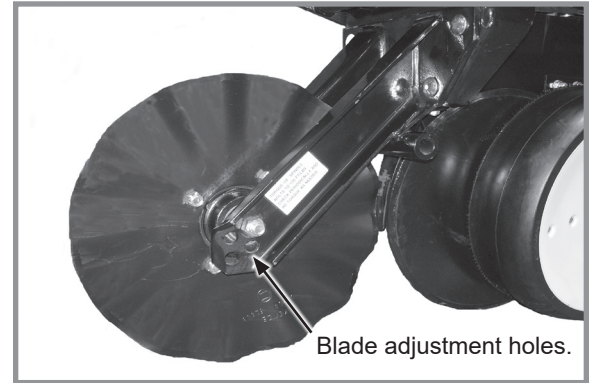

**Row Unit Mounted No Till Coulters**

## COULTER MOUNTED RESIDUE WHEELS

Coulters mounted residue wheels are designed for use on pull row units and push row units. Row unit extension brackets are required on the four center pull row units if the planter is equipped with coulters mounted residue wheels.

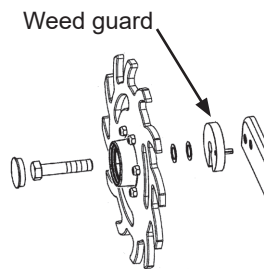

**NOTE: Opening in weed guard must face down.**



**Coulters mounted residue wheels**

Residue wheels attach to row unit mounted coulters with two cap screws and sleeves allowing unit to free-float. A 2-position spindle bolt mounting positions wheels interlocked or staggered. Depth adjustment is made with a spring-loaded cam and pin with 11 positions in 6 mm increments. A high point on the cam allows wheels to be locked up.

A weed guard on the inboard side of each wheel helps prevent weed wrap which can cause premature bearing failure.

## SPIKED CLOSING WHEEL

Spiked closing wheels crumble the sidewall, allowing roots to penetrate soil. They can be used on pull row units and push row units.

Align spiked closing wheels straight across from each other, in most rearward holes on closing wheel arm. Set the wheels 1" - 1¼" (~2,5 - 3,1 cm) apart at the closest point. If large amounts of contouring is being done, mount wheels in the forward most hole. This will reduce drifting of row unit.

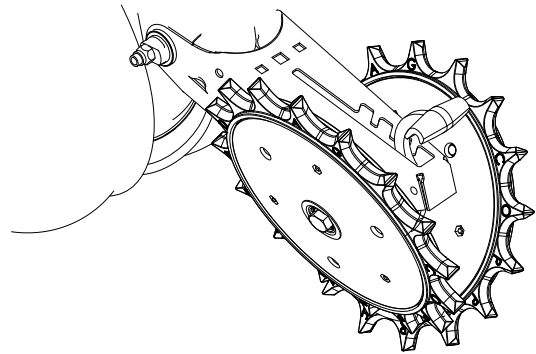

Row Unit Spiked Closing Wheel

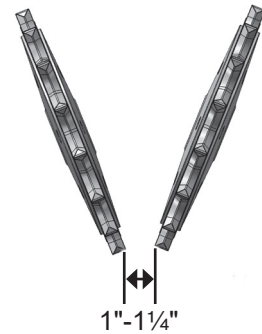

## GRANULAR CHEMICAL HOPPER AND DRIVE



### WARNING

Agricultural chemicals can cause death or serious injury to persons, animals, and plants or seriously damage soil, equipment, or property. Read and follow all chemical and equipment manufacturers labels and instructions.

The granular chemical hopper has a 40L capacity.

Make sure no foreign objects get into hopper when it is being filled. Replace hopper lids after filling to prevent accumulation of dirt and moisture.

A metering gate on bottom of hopper regulates the application rate. See “Dry Insecticide and Dry Herbicide Application Rate Charts” in this manual. Calibrate using chemical manufacturers’ instructions.



Granular chemical hopper

Granular chemical clutch drive coupler and meter shaft can be disengaged and engaged by turning throw out knob at rear of hopper support panel.

Rotate knob  $\frac{1}{4}$  turn counterclockwise to disengage and  $\frac{1}{4}$  turn clockwise to engage.

Slotted holes in hopper support panel and clutch housing allow for alignment adjustment between clutch drive coupler and meter shaft.

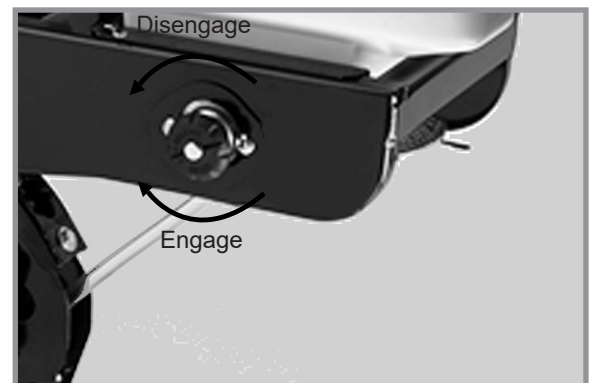

Granular chemical drive release

### GRANULAR CHEMICAL BANDING OPTIONS

Granular chemical banding options allow 4½" (115 mm) slope-compensating banding or straight drop in-furrow placement.

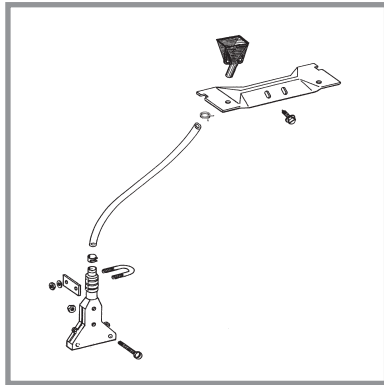

4½" (115 mm) slope-compensating bander

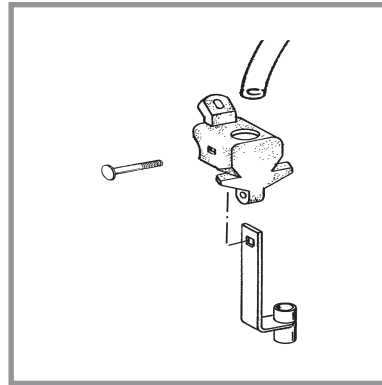

Straight drop in-furrow placement

### GRANULAR CHEMICAL BANDER SHIELD

Optional granular chemical bander shield is installed on underside of wheel arm stop to shield crop residue from lodging in granular chemical bander.

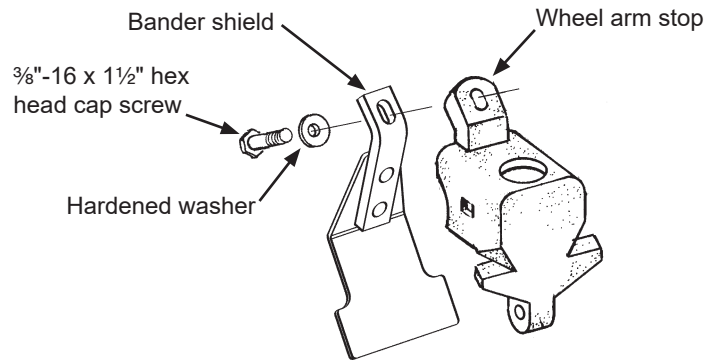

Granular chemical bander shield installation

## DOUBLE DISC FERTILIZER OPENER

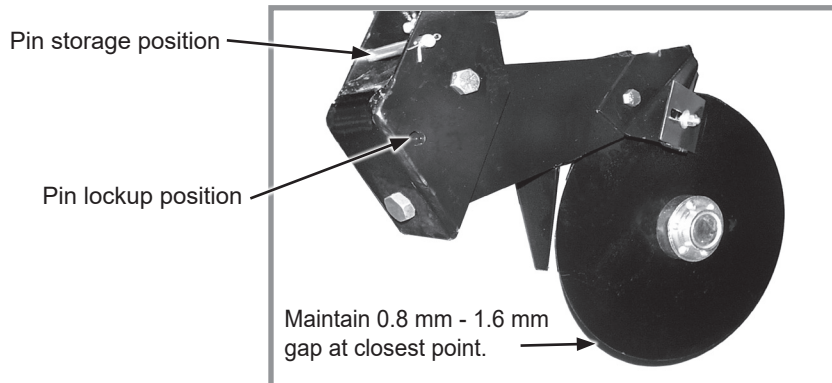

Double disc fertilizer opener

Position double disc fertilizer openers **to place fertilizer no closer than 5 cm to either side of row**. Fertilizer depth is approximately 10 cm if planter frame is level and at proper 51 cm operating height. Soil conditions can affect depth slightly.

**NOTE: Do not set opener depth with spring pressure. Opener is designed to operate against a depth stop and spring up when encountering a foreign object or hard ground.**

Down pressure spring is factory preset at 113 kg but can be adjusted for various soil conditions.

1. Loosen jam nut with a  $\frac{15}{16}$ " wrench.
2. Use a 1" wrench to turn adjustment bolt clockwise to increase tension or counterclockwise to decrease tension.
3. Tighten jam nut.

### NOTICE

**Do not operate double disc openers at full down pressure tension on rocky ground or disc blades will chip.**

Maintain a gap of 0.8 - 1.6 mm between opener blades at the closest point. Blade adjustment is made by moving inside spacer washers to outer side of blade. Check bearing assembly rivets are not contacting shank after making adjustment.

Outer scrapers on each disc blade can be adjusted for wear. Make sure scrapers are adjusted to allow only slight blade contact.

Opener assembly is designed to be locked in a raised position when fertilizer attachment is not in use or during storage.

1. Raise planter and place blocks under openers.
2. Lower planter until pivot section hole aligns with mounting bracket hole.
3. Remove lockup pin from mounting bracket storage position and install through lockup hole.
4. Secure with cotter pins.

**NOTCHED SINGLE DISC OPENER**

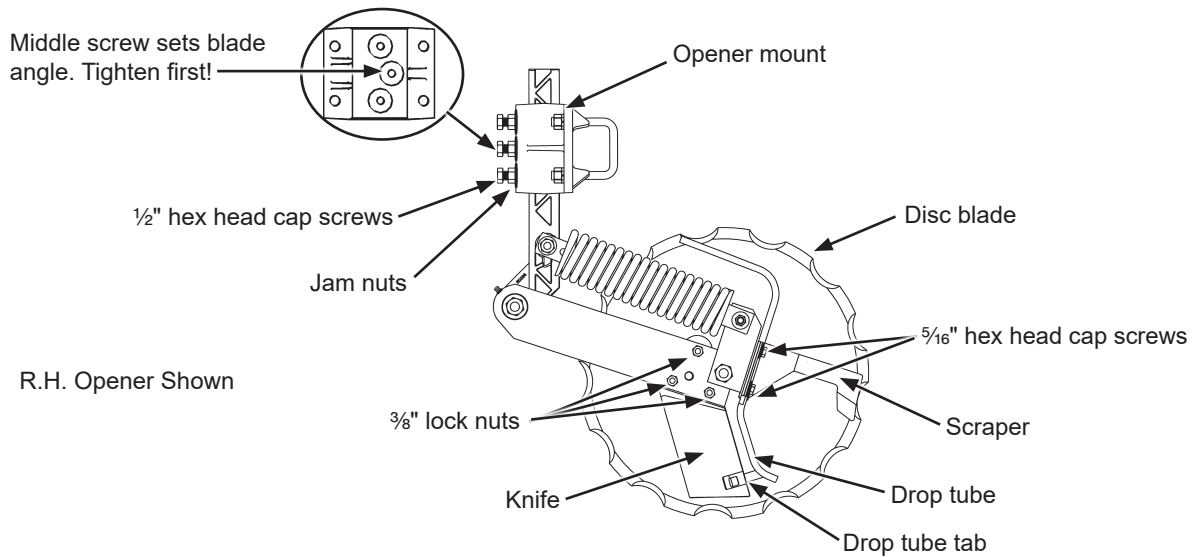

**Notched single disc opener adjustments**



**CAUTION** Compressed spring may fly out of this assembly if attempting to disassemble and cause injury. Do not take apart this assembly.

Disc blades are sharp and can cut causing serious injury. Wear gloves when working on or turning disc blades by hand.



**NOTICE** Never strike knife with heavy object. Damage to knife will occur.

If knife to disc blade clearance is too large, soil or residue can wedge between knife and blade, and blade will not turn.

1. Adjust knife to disc blade contact. Loosen or tighten 3/8" lock nuts to adjust knife's entire leading edge against disc blade. Turn blade and check for slight resistance without freewheeling. Readjust knife to blade's tight spot as needed.



**NOTICE** Adjust liquid drop tube out of path of soil flow across knife. Drop tube and tab wear quickly if not correctly adjusted.

2. Adjust scraper and drop tube. Loosen two  $\frac{5}{16}$ " hex head cap screws. Adjust scraper until just touching disc blade. Adjust drop tube until it is centered between knife and disc blade. Tighten screws. Turn blade and check for slight resistance without freewheeling. Repeat as needed. Insert flat bladed pry bar or screwdriver between knife and drop tube above drop tube tab. Carefully bend tube until 6 - 10 mm from disc blade.

**NOTE: Maximum disc blade depth 10 cm.**

3. Adjust blade depth. Loosen three  $\frac{1}{2}$ " hex head cap screws and jam nuts in opener mount. Adjust opener assembly up or down to desired blade depth. Tighten center hex head cap screw and jam nut first to set proper disc blade angle. Tighten remaining hex head cap screws and jam nuts. Torque hex head cap screws and jam nuts to 77 Nm. Check fertilizer hose clearance and adjust as necessary.

## RESIDUE WHEEL ATTACHMENT FOR NOTCHED SINGLE DISC FERTILIZER OPENER

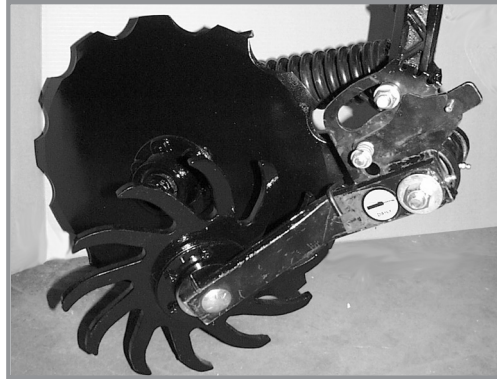

**Notched single disc opener residue wheel attachment**

Residue wheel attachment for notched single disc fertilizer opener is used where row unit mounted residue wheel attachments cannot be installed. Residue wheel is attached to notched single disc fertilizer opener with  $\frac{5}{8}$ " x  $7\frac{1}{2}$ " (L=190 mm) and  $\frac{1}{2}$ " x  $6\frac{1}{2}$ " (L=165 mm) hardware.

Maximum depth is set by lifting residue wheel and moving adjustment lever down to increase depth or up to decrease depth in 25 mm increments (in relation to blade depth setting). Adjust all rows the same. Residue wheel down force is maintained by a torsion spring and is not adjustable.

## DEPTH/GAUGE WHEEL ATTACHMENT FOR NOTCHED SINGLE DISC FERTILIZER

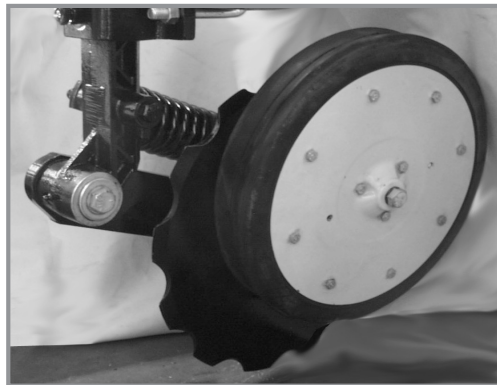

**Notched single disc opener depth/gauge wheel**

Depth/gauge wheel attachment for notched single disc fertilizer opener is used where additional gauging is required to maintain desired fertilizer opener depth. Depth/gauge wheel is attached to notched single disc fertilizer opener using a mounting block fastened to the pivot arm with  $\frac{5}{8}$ " hardware through disc blade bearing.

Depth adjustment is made using 3 adjustment holes in depth/gauge wheel mounting block. Moving depth/gauge wheel increases/decreases depth in approximate 25 mm increments in relation to blade depth setting made at vertical mounting post.

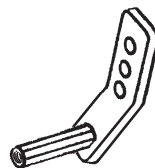



**HD SINGLE DISC FERTILIZER OPENER**

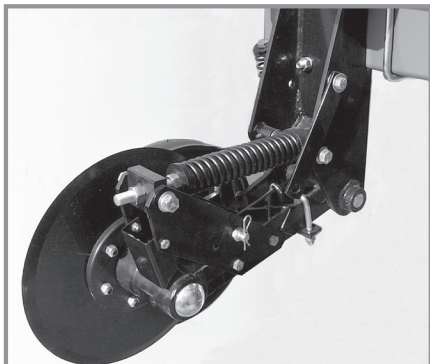

**HD single disc opener**

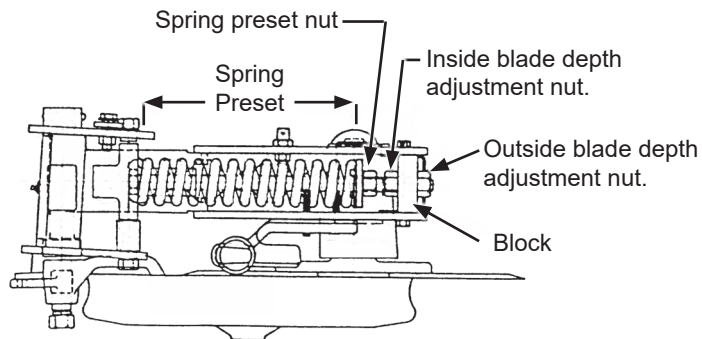

**R.H. configuration shown (Overhead view)**

Recommended placement of fertilizer with HD single disc fertilizer opener is 9 - 10 cm) from row.

<b>NOTICE</b>	<b>Never place fertilizer closer than 5 cm to row or seeds may be damaged.</b>
---------------	--

Maximum blade depth is approximately 13 cm with planter frame level and at 51 cm operating height. Soil conditions can affect depth slightly.

Raise planter to remove weight from fertilizer opener. Loosen inside adjustment nut with 1½" wrench. Turn outside nut clockwise to decrease or counterclockwise to increase blade depth. One full turn of blade depth adjustment nut changes blade depth ⅜". Tighten inside nut tight against block. Adjust all fertilizer openers to same depth.

Fertilizer opener down pressure can be adjusted from 113 kg to 290 kg.

<b>NOTICE</b>	<b>Do not operate HD single disc fertilizer openers at full down pressure tension on rocky ground or disc blades will chip.</b>
---------------	---

**NOTE: DO NOT adjust spring preset dimension less than 24 cm.**

**NOTE: Excessive down pressure can cause planter frame up-lift and affect machine performance. Planter frame should be 51 cm from ground in planting position. Excessive down pressure in loose soil conditions can cause openers to run too deep and push dirt ahead of opener and may stop soil press wheel and opener blade from turning.**

Raise planter to remove weight from fertilizer opener. Turn spring preset nut clockwise to increase and counterclockwise to decrease down pressure. Adjust all rows to a similar setting. Minimal spring pressure for acceptable operation is recommended. See chart for spring length setting specifications.

Spring Preset	
Length	Down Pressure
27.9 cm	113 kg
27.3 cm	145 kg
<b>26.7 cm</b>	168 kg
26.0 cm	204 kg
25.4 cm	236 kg
24.8 cm	263 kg
22.9 cm	290 kg
*Initial setting	

Adjust spring loaded dry fertilizer drop tube/scrapper periodically to maintain 3 mm gap between drop tube and opener blade. If this dimension is not maintained fertilizer may not drop in proper location.

Loosen scraper adjustment bolt. Slotted hole in scraper allows up or down adjustment.

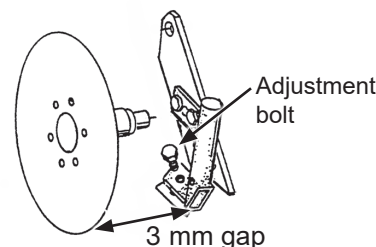

Adjust liquid drop tube/scraper so there is slight contact between blade and scraper lower leading edge, and 6 mm clearance between liquid drop tube trailing edge and blade. Blade should turn with minimum amount of drag.

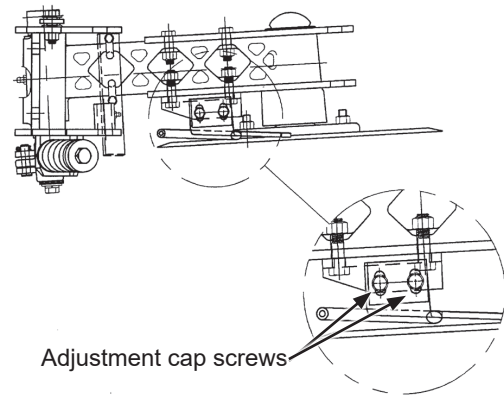

HD single disc fertilizer opener can be raised and locked up when fertilizer attachment is not used or during storage.

**NOTE: A lockup bar automatically raises and locks soil press wheel when blade assembly is raised.**

1. Place planter in planting position.
2. Remove outside blade depth adjustment.
3. Raise planter until adjustment bolt clears adjustment block.
4. Raise spring to clear blade assembly and raise blade assembly until storage strap can be positioned on lockup pin. Install hair pin clip.
5. Reinstall depth adjustment nut and tighten

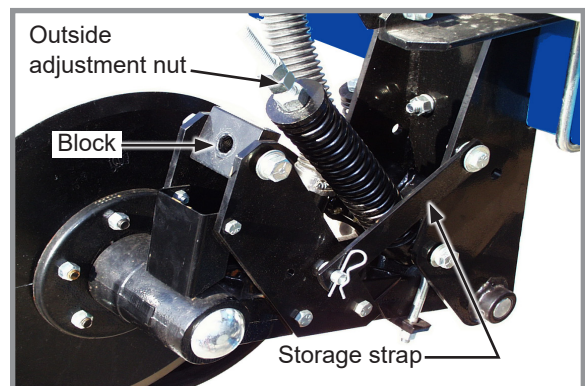

**HD opener lockup**

## DRY FERTILIZER ATTACHMENT



### WARNING

Agricultural chemicals can cause death or serious injury to persons, animals, and plants or seriously damage soil, equipment, or property. Read and follow all chemical and equipment manufacturers labels and instructions.



**Dry fertilizer option installed**

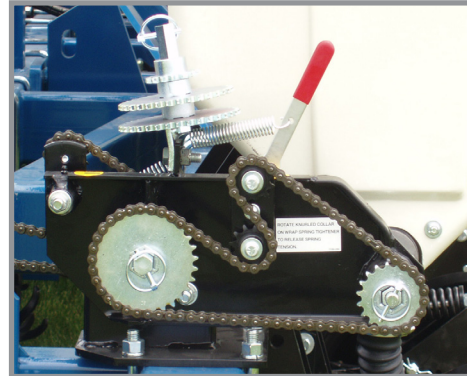

**Fertilizer drive rate transmission**

Rate of fertilizer application is determined by drive/driven sprocket combination on fertilizer drive rate transmission and auger position in the hoppers.



**Augers positioned for high rate delivery**

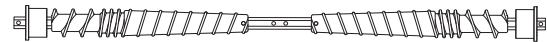

**Augers positioned for low rate delivery**

**NOTE: Uneven delivery of fertilizer will occur if high rate auger position is used at too low a rate setting.**

Remove ¼" stainless steel cap screws holding augers in place on shaft and reposition augers to change delivery rate.

A fertilizer transmission is located directly ahead of row unit transmission on right side of planter and allows simple, rapid changes in sprockets to obtain desired fertilizer application rates. Chain tension is controlled by a spring loaded idler adjusted with a ratchet arm located to inside of transmission. Sprockets can be changed with those on the sprocket storage rod by removing hexagon shaft pins. Fertilizer rate charts in Rate Chart section will help you select correct sprocket combinations.

**NOTE: Make a field check after each sprocket combination adjustment to be sure you are applying fertilizer at desired rate.**

### NOTICE

Placing fertilizer too close to seeds or in excessive amounts can cause germination or seedling damage. Check with your fertilizer dealer or manufacturer for correct amount and placement.

Because dry fertilizer attachment meters granules by volume rather than weight, differences in brands, and fertilizer analysis, weight metered during actual application may vary considerably. Use chart for reference only. Use a container to catch and measure application for a better estimate.

Keep fertilizer dry during use and storage since most fertilizers easily absorb moisture. In addition to waste, deposits of fertilizer left in hopper can cause metal corrosion. Empty hoppers at end of each day.

CLEANING

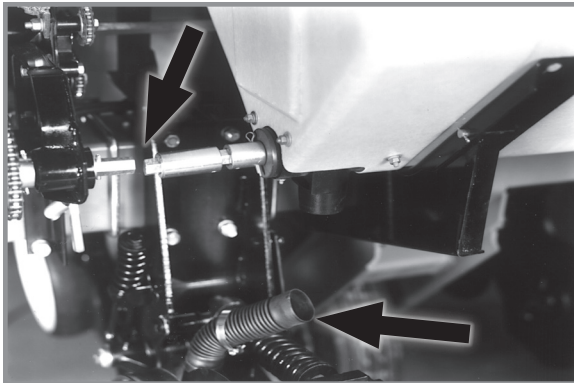

**Disconnect drive shaft and hoses**

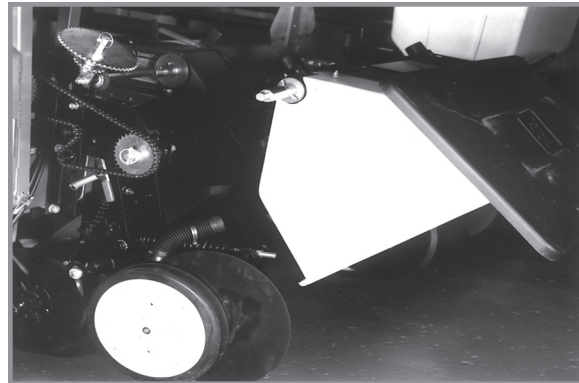

**Rotate lid to back and rotate hopper forward**

Dry fertilizer hoppers tip forward for dumping and ease of cleaning. Disconnect drive shaft from transmission and/or adjacent hopper. **LOOSEN HOSE CLAMPS AND REMOVE HOSES FROM EACH HOPPER.** Remove rear 1/2" x 1 1/4" cap screw from between each hopper saddle and hopper mount. Rotate each hopper lid to back side of hopper and carefully tip hopper forward. Flush all loose fertilizer from hoppers and hoses after dumping contents.

At end of planting season or when fertilizer attachment is not used for a period of time, hoppers should be disassembled, cleaned, and metal surfaces coated with a rust preventative. Remove 1/4" cotter pin and bearing from one end of shaft. Pull auger assembly from opposite end of hopper. Remove stainless steel cap screws from auger shaft and remove all auger components for cleaning. Coat all parts with rust preventative before reassembly. Reinstall auger halves in low or high rate position.

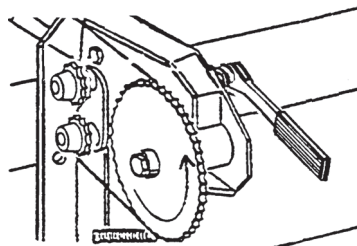

**Transmission direction of rotation**

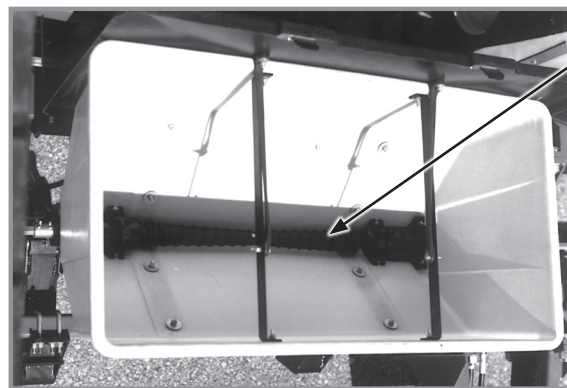

Flighting must move chemicals from center to outside of hopper.

**Auger installation**

**NOTE: Install auger assembly so the flighting moves material to outer openings in hopper when augers rotate in direction they turn during operation.**

Slide auger assembly through outlet housing into hopper. Secure in place by reinstalling bearing and cotter pin. Rotating shaft in direction shown to see if flighting (spirals) on auger move toward ends of hopper. If not, remove auger assembly, turn 180°, and reinstall.

**NOTE: Frequent lubrication of auger bearings is critical to ensure augers turn freely. Check lubrication section for frequency.**

Be certain augers turn freely. If not, loosen 5/16" carriage bolts in outlet housings, rotate auger several times, and retighten carriage bolts. This allows housings and augers to realign.

**NOTE: Do not operate fertilizer attachment without auger baffles in place.**

Install auger baffles over augers and secure in place with two hair pin clips in each hopper.

## LIQUID FERTILIZER ATTACHMENT

### **WARNING**



Agricultural chemicals can cause death or serious injury to persons, animals, and plants or seriously damage soil, equipment, or property. Read and follow all chemical and equipment manufacturers labels and instructions.

### **CAUTION**

Overfilling tank can cause siphoning, tank collapse, personal injury, and damage to property and equipment. Do not overfill tank. Do not leave planter unattended when filling tank. Close fill valve and open tank lid if siphoning occurs. Follow all chemical manufacturers first aid, cleanup, and handling instructions.

### **NOTICE**

Placing fertilizer too close to seeds or in excessive amounts can cause germination or seedling damage. Check with your fertilizer dealer or manufacturer for correct amount and placement.

## CHECK VALVES



**Repairable check valve**

Optional low rate check valves are available for in-line installation between piston pump and openers to ensure equal distribution of product at low rates. Check valves eliminate anti-siphon loops.

PISTON PUMP

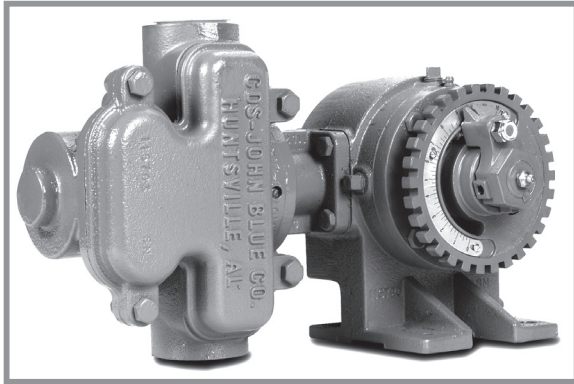

Piston pump

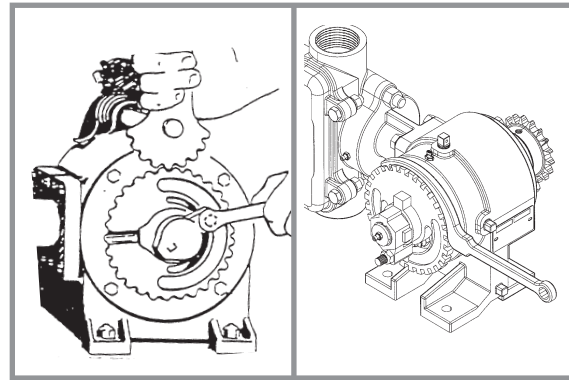

Adjusting delivery rate

**NOTE: Delivery rate chart in the Rate Charts section of this manual provides approximate application rate only. Delivery varies with temperature and fertilizer.**

Loosen  $\frac{3}{8}$ " lock nut that secures arm with pointer and rotate scale flange with adjustment wrench until pointer is over desired scale setting. Tighten  $\frac{3}{8}$ " lock nut. **DO NOT OVERTIGHTEN.**

**NOTE: Periodically check flow to all rows. Set rate is still delivered to remaining rows if one or more lines are plugged.**

PISTON PUMP GROUND DRIVE WHEEL SPRING ADJUSTMENT

Initial down pressure spring tension on piston pump ground drive wheel, is set leaving  $12\frac{1}{4}$ " (~31 cm) between the bottom of mounting plate and plug on top of spring. This dimension is taken with planter raised (tire not contacting the ground). Further adjustment can be made to fit conditions.

**NOTE: Piston pump ground drive wheel assembly can be locked in raised position when not in use. Remove two cap screws that attach upper end of spring to spring mount. Reattach spring using upper holes in spring mount. Reverse procedure to reset for field use.**

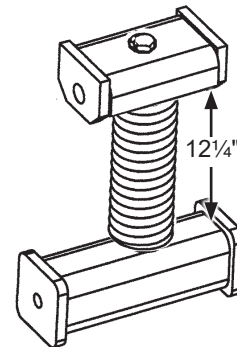

CLEANING

Clean tanks, hoses, and metering pump thoroughly with water at end of planting season or prior to an extended period of non-use. Do not allow fertilizer to crystallize from cold temperature or evaporation.

On machines equipped with piston pump, take apart and clean strainer located between piston pump and ball valve daily. Remove the end cap to clean the screen. See Piston Pump Storage in Maintenance Section of this manual.

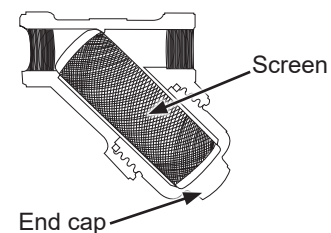

## Blue Vantage Liquid Fertilizer

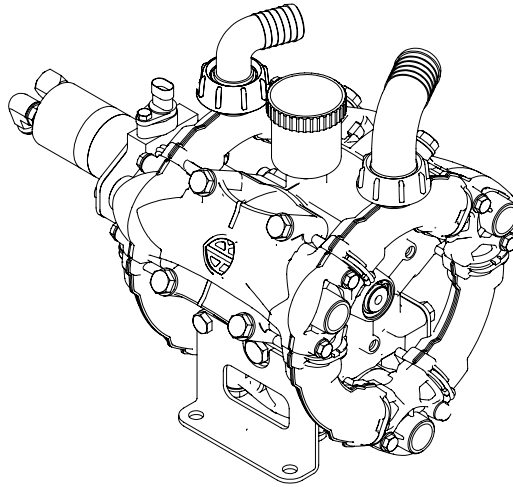

### CAUTION

**DO NOT** use the diaphragm pump without first checking that the intake and delivery circuit pipelines are correctly secured and free from leaks.

**DO NOT** draw in liquids at temperatures above 50°C and below 5°C.

**DO NOT** use the pump for flammable, toxic or corrosive liquids or liquids with unsuitable density, especially solvents or residue of any kind.



### CAUTION

Before doing any maintenance work, depressurize the liquid system and isolate the pump from all energy sources.

When the jobs are done, before restarting the pump, check that no tools, rags or other materials have been left close to moving parts or in hazardous zones.

### NOTICE

Before start-up, the operator must perform the necessary safety checks.

In the event of leaks from the pressurized pipes, stop the pump at once and fix the leak.

### NOTICE

During the first few hours of operation, check that the oil level in the tank remains between the minimum and maximum limits. If top-ups are required, use oil specified in the Maintenance section of the manual.

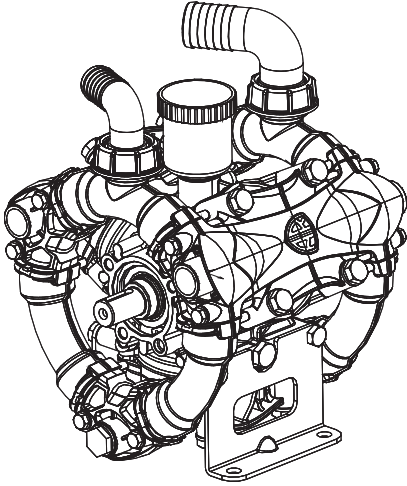
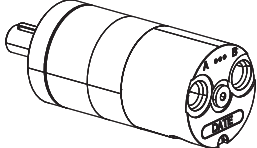
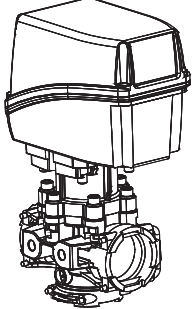
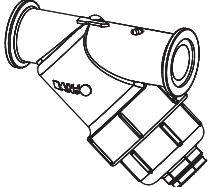
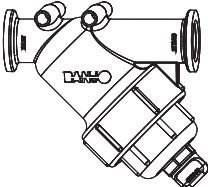

**Fertilizer Systems Parts Overview**

**NOTE:** See parts manual for part numbers.

COMPONENT		DESCRIPTION
Diaphragm Pump	 <p style="text-align: center;">3 Cylinder</p>	<p>Oil Capacity: 1 L</p> <p>Diaphragm Kit: Available, see parts manual.                      Check Valve Kit: Available, see parts manual.                      Seal Kit: Available, see parts manual.                      Oil: Available, see parts manual.                      Winterizer: Available, see parts manual.</p>
Hydraulic Motor		<p>Fertilizer Pump Motor. Small pump and large pump have different motors.</p> <p>Seal Kit: Available, see parts manual.</p>
Pressure Regulator		<p>Controls delivery manifold pressure and bypasses overhead flow for agitation.</p>
Suction Strainer		<p>30 mesh.</p> <p>Clean regularly.</p>
Pressure Strainer		<p>80 mesh.</p> <p>Clean regularly.</p>

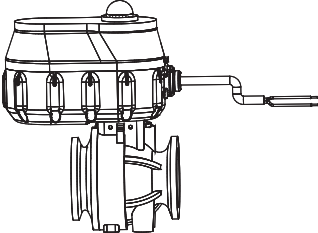
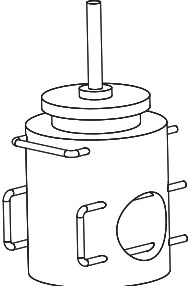
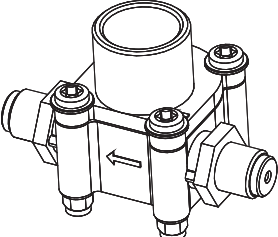
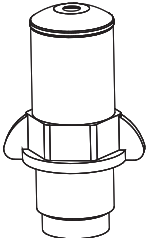
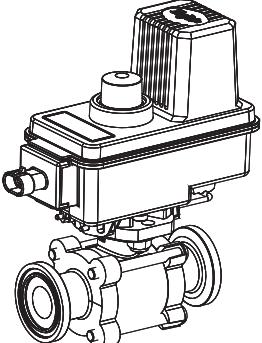

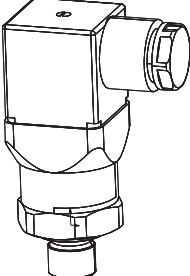
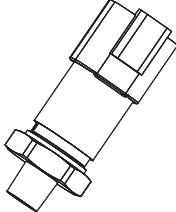
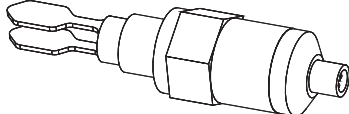
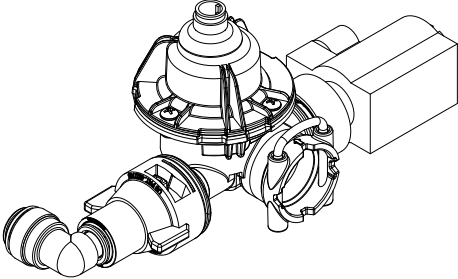
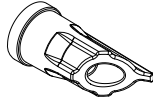
COMPONENT		DESCRIPTION
Suction Ball Valve		<p>ON/OFF valve that opens flow of fertilizer to the pump. This is feature is used when entering planting task in Blue Vantage.</p>
Large System Flow Meter		<p>Full flow flow meter.</p>
Small System Flow Meter		<p>Arrows on housing indicates direction of flow.</p>
		<p>Small flow meter sensor.</p>
Small Ball Valve		<p>Closes to send flow through small flowmeter at low flow rates.</p>

COMPONENT		DESCRIPTION
Suction Sensor		Located in suction strainer. Sends pump suction pressure to Blue Vantage controls.
Pressure Sensor		Sends delivery manifold pressure to Blue Vantage controls.
Fluid Switch		Located in tank for low level alert.  Located in suction circuit to know when pump has fluid supply.
Row Flow Meter		Indicates flow or no flow to each row.
Jet Orifice		Used for all orifices smaller than .055 and not used for .065 and larger.
4916 Orifice		Different orifices used for different application rates.

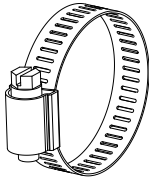
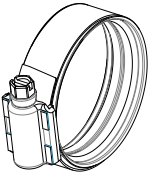
Hose Clamp Torque Values Chart				
 Standard	 Heavy Duty	Diameter	Standard	Heavy Duty
		1¼"	42 in-lb	75 in-lb
		1½"	42 in-lb	75 in-lb
		2"	42 in-lb	X

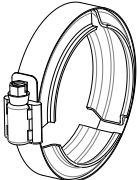
Flange Clamp Torque Values Chart		
	Diameter	Torque
	1"	50-60 in-lb
	2"	90-100 in-lb

### LIQUID FERTILIZER SYSTEM SCHEMATICS

Fertilizer is controlled through the Blue Vantage display. You can increase or decrease fertilizer rate, turn fertilizer function on or off, and load a prescription. Refer to your Blue Vantage manual for more information.

Rear Trailer or Hitch Auxiliary Tank

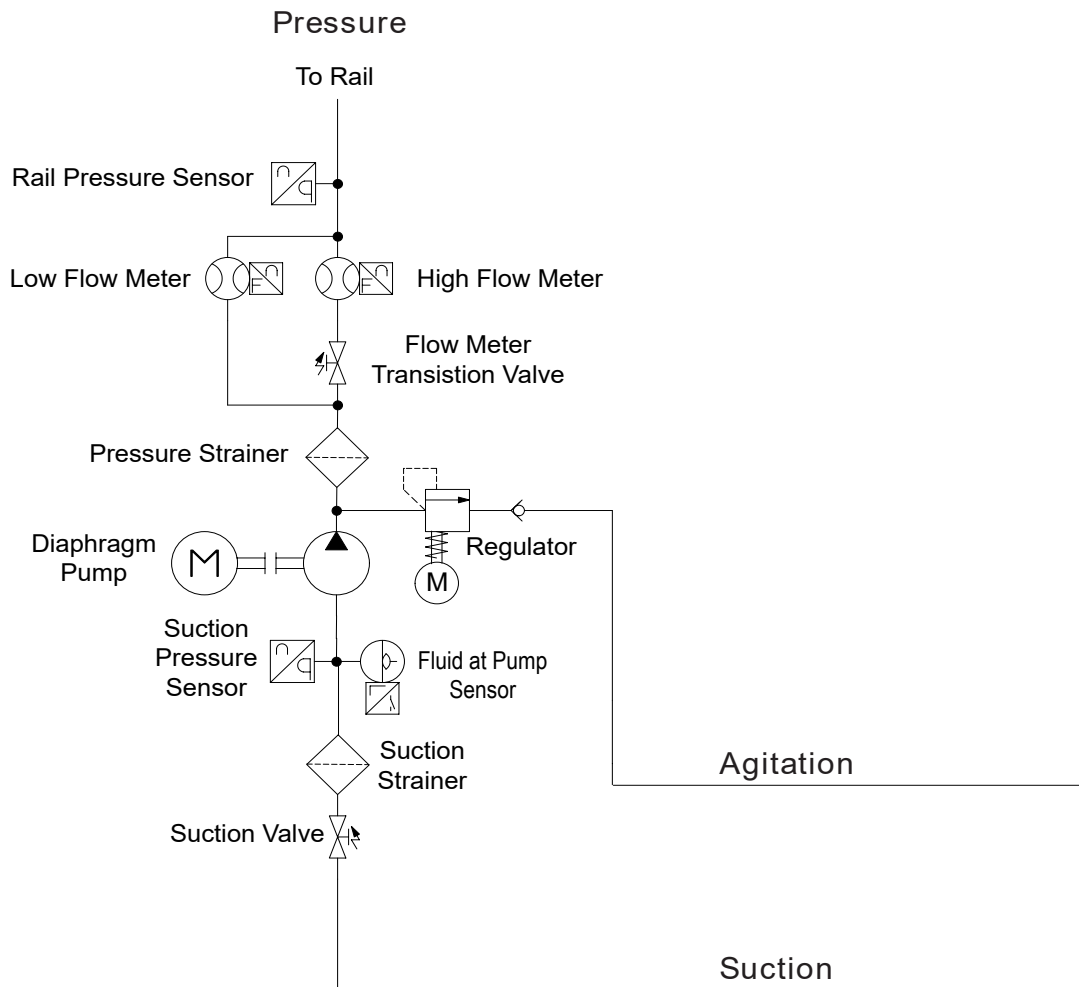

### System Overview

#### Diaphragm Pump - Model Number AR120

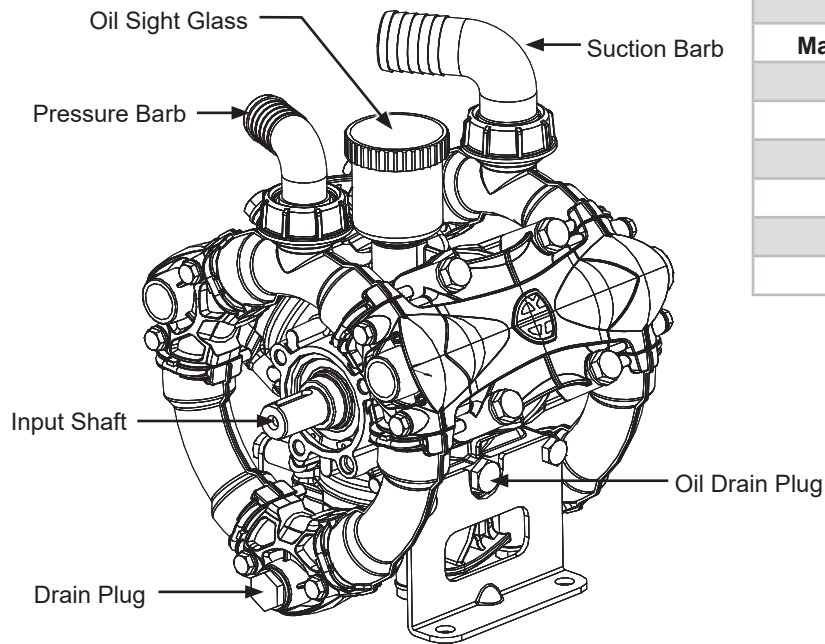

Operating Pressure Range	
	AR120
Max GPM (Max L/min)	30.8 (116.6)
Max PSI (Max kPa)	220 (1517)
Weight	15.4 kg
Cylinders	3
Oil Capacity	1 L
Max Speed (RPM)	550
Pulsation Damper	No

Diaphragm pumps are reciprocating positive displacement pumps. Reciprocating movement of the diaphragms expands and compresses volumes. This mechanical work and change in volumes cause transfer of liquid. The main difference between a diaphragm pump and other types of reciprocating pumps, is the presence of a flexible separating component (the diaphragm) between mechanical parts and pumped liquid circuit. This enables diaphragm pumps to transfer liquids which would be detrimental to other types of reciprocating pumps. Pistons are generally in a “Boxer” type opposing cylinder arrangement, or in a radial layout around the axis of the crankshaft which drives them.

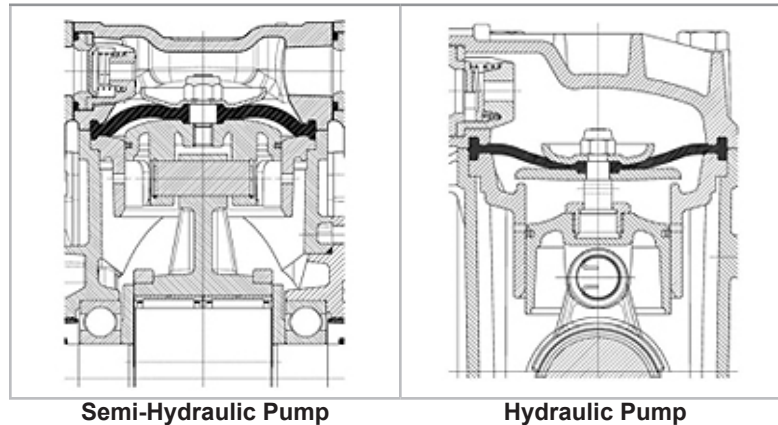

The piston is mechanically connected to diaphragm. The diaphragm is mechanically operated by piston at it's center and at the same time it's outer edge ensure a watertight seal around the pumping chamber. In a “semi-hydraulic diaphragm pump”, the diaphragm is rigidly secured to piston by a stud screwed on the piston and a plate tightened by a nut. In a “Hydraulic diaphragm pump” the center of the diaphragm is fixed to a floating component on piston. The suction and delivery valves, fitted at the pumping chamber suction and delivery ports, are operated by the alternating negative and positive pressure inside circuit.

Suction

During the suction stroke (piston retreating), the difference between the suction pressure and the pressure inside the pump head open the suction valve and closes the delivery valve. The transferred liquid is drawn into the head by the suction line.

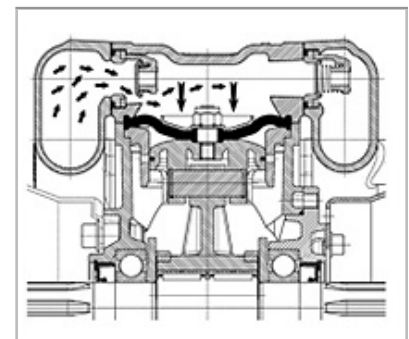

**Suction**

Compression

During the compression stroke (advancing piston), the suction valve closes and the delivery valve opens due the pressure generated inside the head by the piston. The transferred liquid is pumped out of the head and into the delivery line.

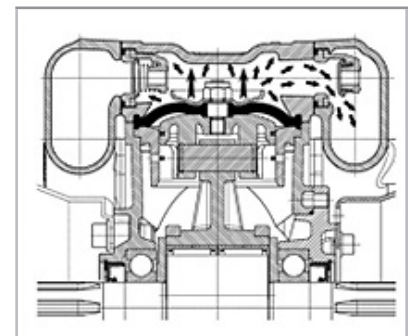

**Compression**

Oil

When pump is new, oil in tank is clear and yellowish in color. After a few operating hours, the oil in tank loses its transparency and becomes dark due to metal particles removed by rubbing of internal components during functioning. This is normal color for this type of diaphragm pump. This occurs regardless of the type of oil used and pump's working conditions. In heavy-duty working conditions, oil will become dark more quickly. When oil in the tank becomes light grey and looks milky (color also depends on color of the liquid being pumped), stop using the pump immediately, it is likely that one or more diaphragms have ruptured, allowing the aqueous solution pumped to pass into the lubricating oil and form a water/oil emulsion inside pump body.



Oil in New Pump



Oil in Functioning Pump



Oil After Diaphragm Rupture

Replacing Diaphragms

Aside from its lubricating function, in diaphragm pumps the oil passes through the calibrated holes in the sleeves uncovered at every piston stroke to form a protective cushion between piston and diaphragm. The volume of this oil cushion is not constant; it varies with pressure/vacuum inside pumping chamber. However, the oil cushion is only effective when it does not contain residual air. After replacing diaphragms the oil cushion should be restored, by removing as much air as possible inside the body and specifically between pistons and diaphragms

Restore oil cushion:

1. Calibrated holes in the sleeves must always be mounted in vertical position, allowing air to flow out, and cap must be off tank.
2. Before proceeding weigh quantity of oil stated in manual for the specific pump model.
3. Turn pump shaft by hand and tilt at various angles; air bubbles will be seen coming out of tank.
4. When the entire amount of oil specified for the pump has been poured in, oil is between the minimum and maximum level marks on the tank and no air is bubbling out. The system has been vented correctly.

**NOTE: Particularly heavy or bulky pumps can be operated at low RPM for a few minutes at 0 bar without oil cap on oil sight reservoir. Air bubbles will come out, causing level to drop. Top up until entire quantity of oil specified for the pump has been added.**

**NOTE: During operation, if working pressure increases, the level in tank will increase, if pump is working with a high suction pressure (obstructed filter, suction from a strong gradient), level in tank will reduce.**

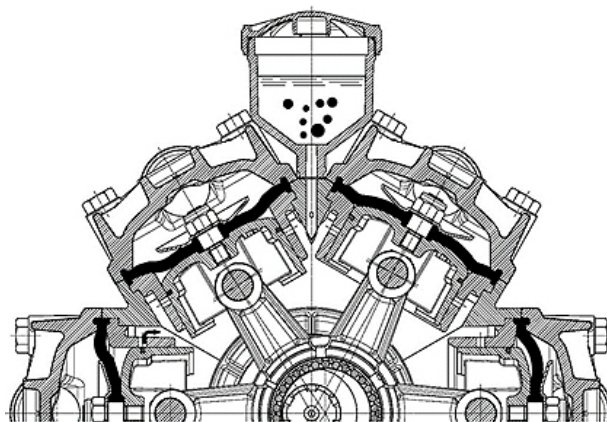

Improper Fertilizer Pump Operation

- Do not use the pump in a potentially explosive atmosphere.
- Do not use the pump for flammable, or liquids with unsuitable density, especially seawater, adhesives, bitumens, asphalt sealers, two-step curing compounds, concrete sealers, liquefied gases or solvents of any kind, paints of any kind or liquids containing solids in suspension.
- Do not draw in liquids at temperatures above 122°F (50°C) or below 41°F (5°C).
- Do not use the pump in drinking water supply systems.
- Do not use the pump on products for human consumption.
- Do not use the pump without first checking that the intake and delivery circuit pipelines are correctly secured and free from leaks.
- Do not use the pump without the safety devices provided: guards for shafts and drive couplings and suitably rated relief valve on the delivery circuit.
- Do not use the pump to wash or spray: people, animals or delicate items, live electrical equipment or chemicals whose characteristics are not known.



Servicing Pump

Refer to the parts manual for all service kit part numbers. Use the chart below for maintenance intervals.

MAINTENANCE INTERVAL	ACTION
Each time used.	Check level and status of oil.
	Check suction filter and clean if necessary.
Every 50 hours.	Check pulsation damper inflation pressure (if applicable).
	Check if suction line is intact.
	Check if pump is tightly fastened to chassis of machine. <b>NOTE: Should the pump not be securely fastened, DO NOT use the machine for any reason.</b>
Every 300 hours.	Check the diaphragms and replace if necessary. Replace all diaphragms in the pump, regardless of conditions if aggressive chemicals are used.
	Check damper diaphragm (if applicable) and replace if necessary.
	Replace oil. Oil MUST be changed every time diaphragms are replaced. First oil change must be made after 300 hours.
	Check to be sure pump screws are tight. If pump operates in conditions of heavy vibration, check more frequently.

Checking Oil Level

- Check oil with pump level, ensuring that it has been running for at least 5 minutes in normal working conditions.
- If oil level is not visible or completely full, add or remove oil to restore this level and check, still with the pump running, that the oil level does not vary so much that it leaks from the cap or is no longer visible in tank.
- If necessary, **top up with SAE 30 compressor oil.**
- Check oil level regularly, as it may vary significantly with operating conditions.



Topping Up

To top up with oil proceed as described below:

1. Unscrew the cap (B) on the oil sight glass and pour in oil until the level is between the minimum and maximum values indicated (A).
2. Screw the cap (B) back on.

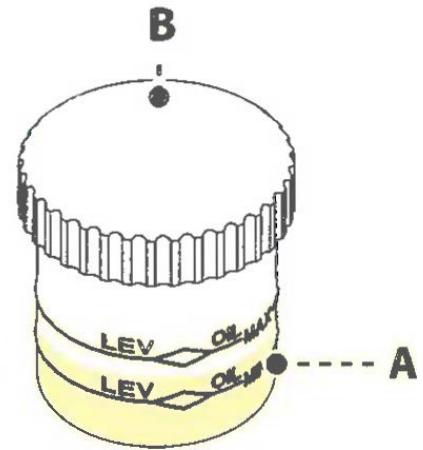

Changing the Oil

To change the oil in the pump, proceed as described below:

1. Loosen the cap on the oil sight glass.
2. Unscrew the oil plug located on the pump casing (C). Use container of an adequate size to drain about a liter of oil from the pump.
3. Let the oil pour out of the pump. Dispose of oil in accordance with local regulations.
4. Refill the pump with about 1 liter of oil using the purge button on the Blue Vantage to spin the pump and get all oil circulated. When oil level stops going down it is adequate.
5. Reinstall the oil drain plug.
6. Reinstall the cap.

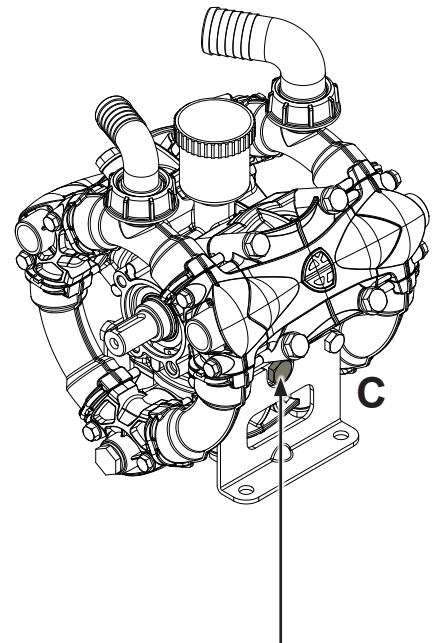

Remove plug to drain oil

**Oil change intervals & conditions**

Every 300 hours of use	Change oil
Grey or milky oil color	Change oil

**ROW FLOW METER****End View**

When planter toolbar is on level ground, check to ensure all flow meter are also as horizontal as possible for best operation. If flow meter is not level while planter is on level ground, adjust by rotating manifold(s).

## ROW FLOW METER CLEANOUT

Fertilizer can salt out when certain conditions of time and temperature are met. This causes a buildup of fertilizer granules in and around areas of low flow. This will cause errors in the performance of the fertilizer flow manifold.

To properly clean, disassemble the entire assembly. Use the illustrations below as a guide for disassembly and reassembly.

Clean all parts thoroughly with clean water at the end of planting season or prior to an extended period of non-use. Do not allow fertilizer to crystallize from cold temperatures or evaporation.

1. Turn cover counterclockwise to unlock and remove cover from flow meter.

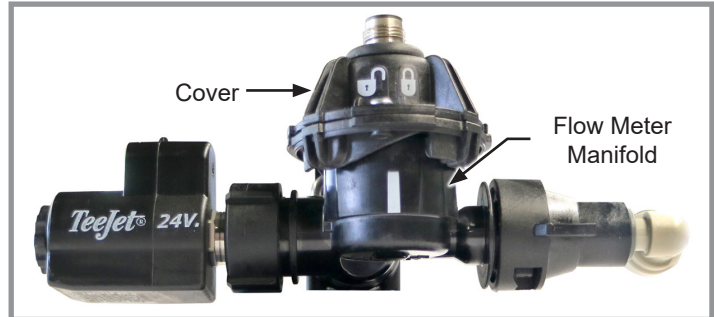

2. Remove paddle wheel from cavity.
3. Clean all parts thoroughly with clean water. Remove any debris inside of cavity.

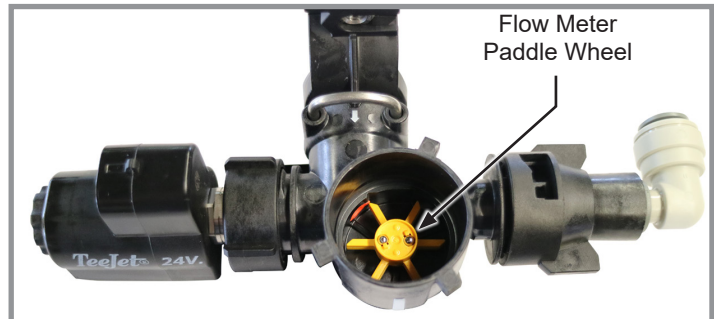

4. Once clean, place paddle wheel back onto pin inside cavity and spin the paddle wheel to ensure it is seated correctly.

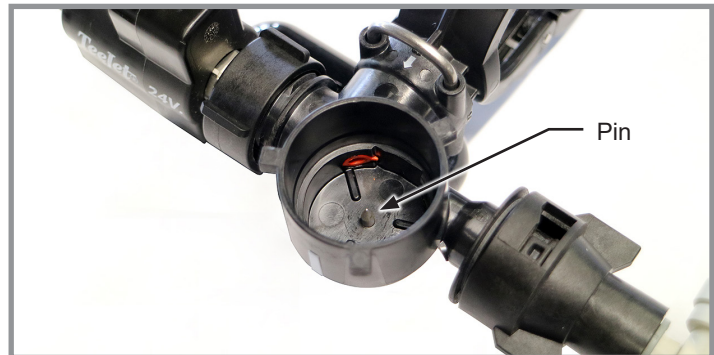

5. Reinstall cover and turn clockwise until the "lock symbol" is directly above the white line.

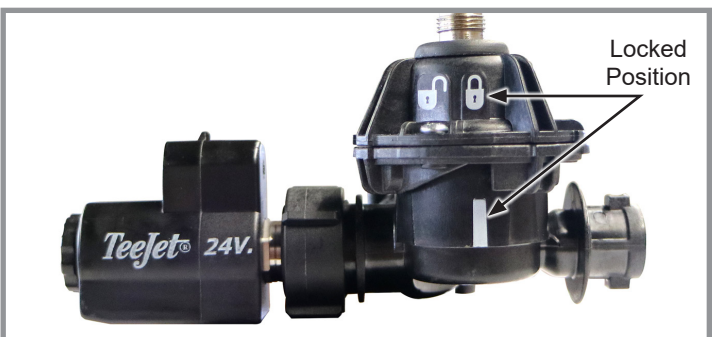

**NOTE: If cover does not go on easily, paddle wheel is not aligned correctly on pin.**

## ROW FLOW METER JET ORIFICE REMOVAL

1. Turn cover counterclockwise to unlock and remove cover from flow meter.

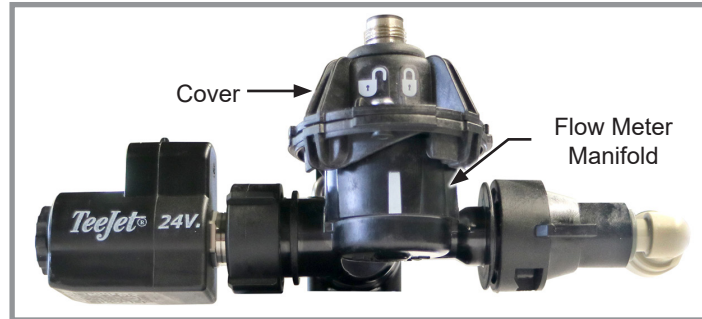

2. Remove paddle wheel from cavity.

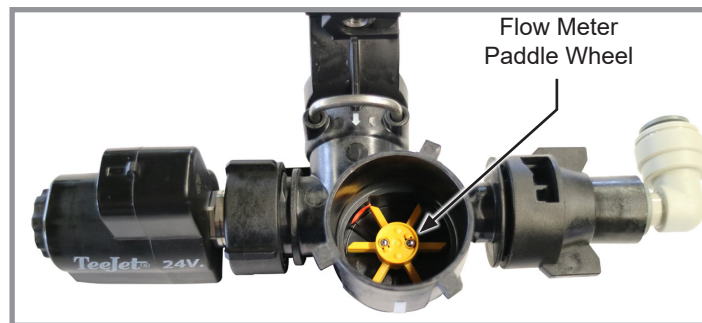

3. Rotate the nozzle assembly counterclockwise 90° and pull nozzle off.
4. Pull strainer out of flow meter.
5. Remove row shutoff valve by spinning nut counterclockwise and pulling valve out.

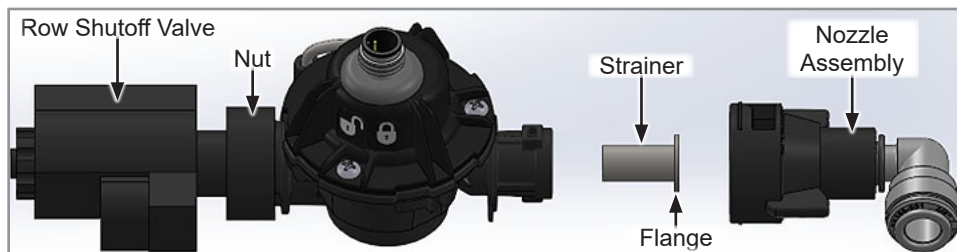

## 6. Remove jet orifice:

- Insert #1 Phillips screwdriver from the nozzle assembly side until the tip is in the jet orifice as shown. Then push the jet orifice out.

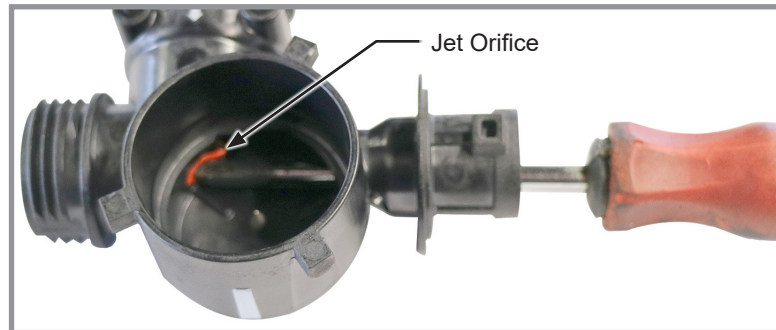

## 7. Reassemble flow meter

- Reinstall row shutoff valve and tighten nut clockwise.
- Place the paddle wheel on the pin in the cavity and spin paddle wheel to ensure it is seated correctly.
- Reinstall cover and turn clockwise until the lock symbol is directly above the white line.
- Reinstall strainer.
- Reinstall gasket, orifice, and nozzle assembly.

## ROW FLOW METER JET ORIFICE INSTALLATION

1. Remove row shutoff valve by spinning nut counterclockwise and pulling valve out.
2. Turn cover counterclockwise to unlock and remove cover from flow meter

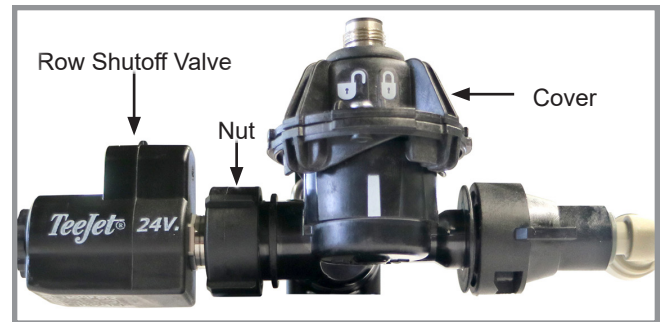

3. Place jet orifice on the end of #1 Phillips screwdriver, with the long tip closest to the rail and pointing toward the paddle wheel cavity.

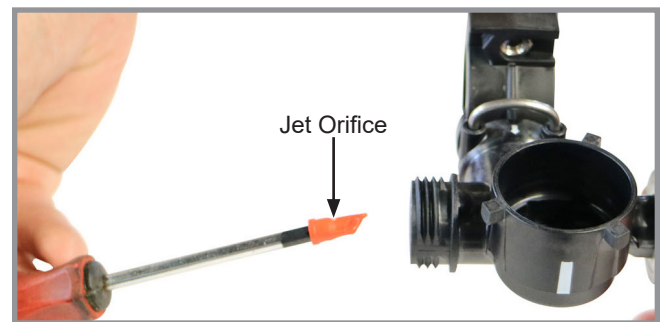

4. Insert jet orifice into center hole on the row shut valves, gently twisting back and forth to help align the rib on the orifice and the groove in the housing. The jet orifice should be flush with paddle wheel cavity wall when installed completely.

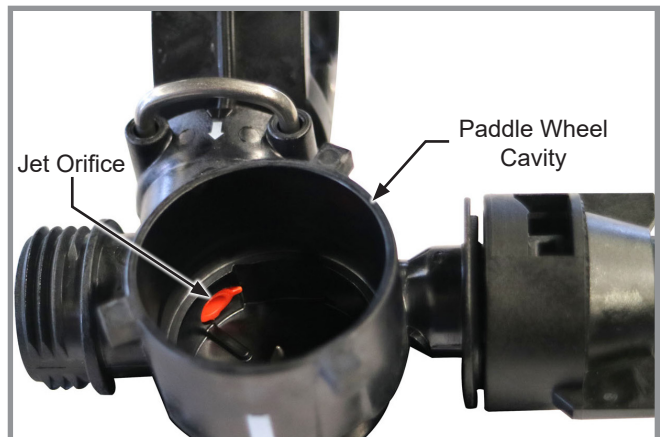

5. Reinstall row shutoff valve and tighten nut clockwise.
6. Place paddle wheel on the pin in the cavity and spin the paddle wheel to ensure it is seated correctly.

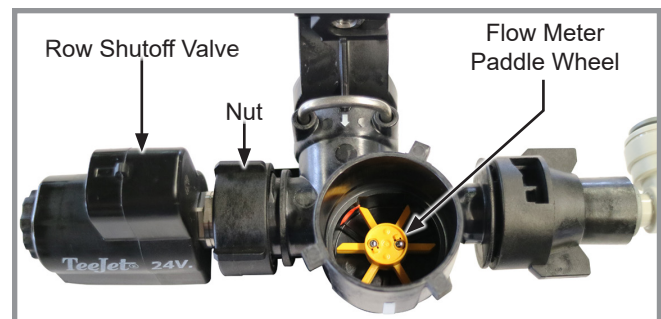

- 7. Reinstall cover and turn clockwise until the lock symbol is directly above the white line.

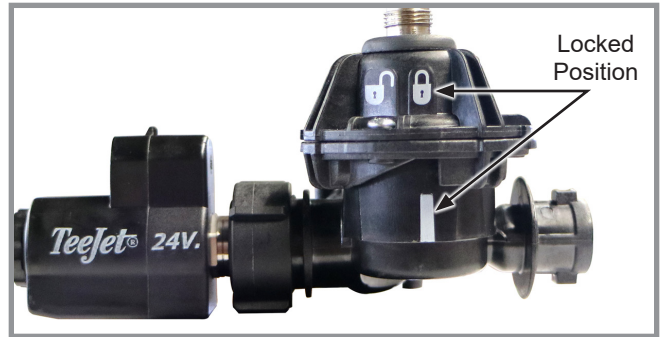

- 8. Reinstall strainer.

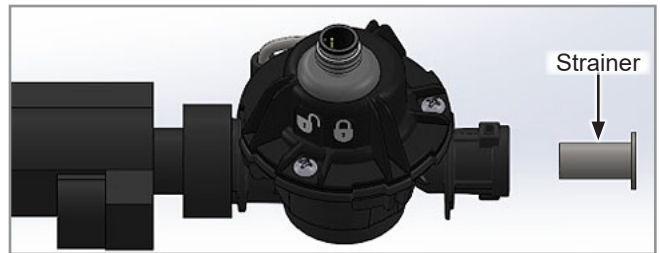

- 9. Reinstall gasket, orifice, and nozzle assembly.

**NOTE: Orifices must be installed correctly. Install orifice with the blank side towards the flow meter manifold and the stamped side facing nozzle assembly (pointing downstream toward the direction of delivery).**

**NOTE: Orifice is installed in center groove of gasket.**

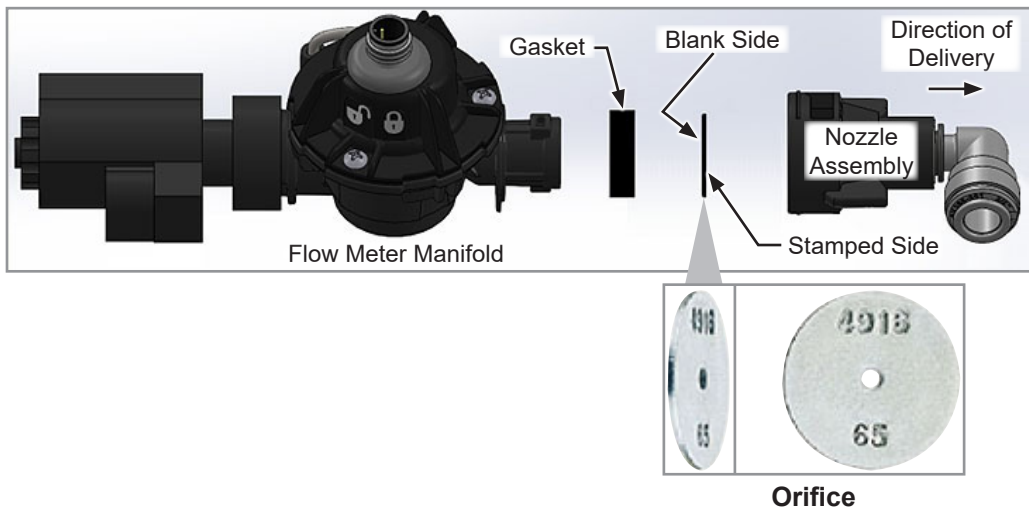



## FLOW METER STRAINER AND ORIFICE CLEANING AND/OR REPLACEMENT

### Strainer

1. Rotate the nozzle assembly counterclockwise 90° and pull nozzle off.

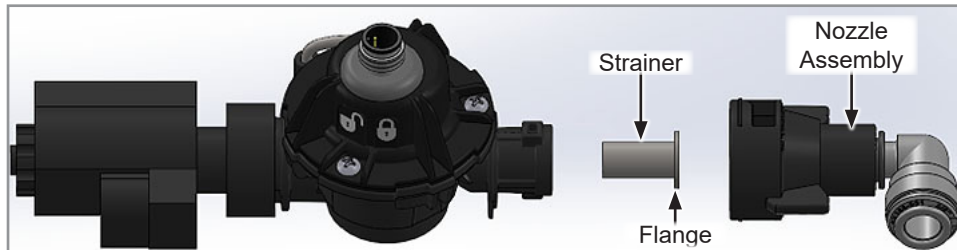

2. Pull strainer out of flow meter and clean or replace it.

**NOTE: Reinstall a clean strainer with the flange towards the nozzle cap. Refer to table to ensure the correct strainer is chosen for the orifice selected.**

Orifice Size	Strainer Mesh Size	Part Number	Color
0.015 and Below	200	G10943201	Pink
0.016 - 0.039	100	G10943101	Green
0.040-0.070	50	GD27290	Blue
0.072 and Larger	---	---	---

**NOTE: If the rail pressure increases during planting, clean the strainers.**

Orifice

1. Rotate the nozzle assembly counterclockwise 90° and pull nozzle off.

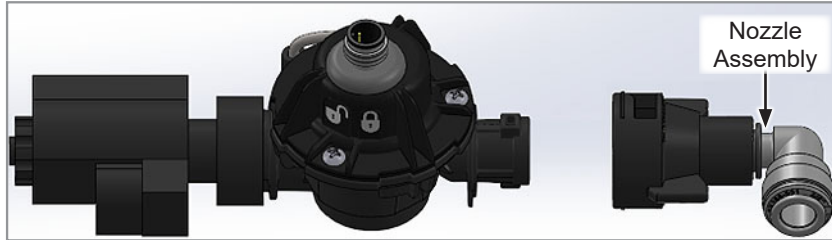

2. Remove gasket with orifice currently installed.
3. Remove orifice from gasket.

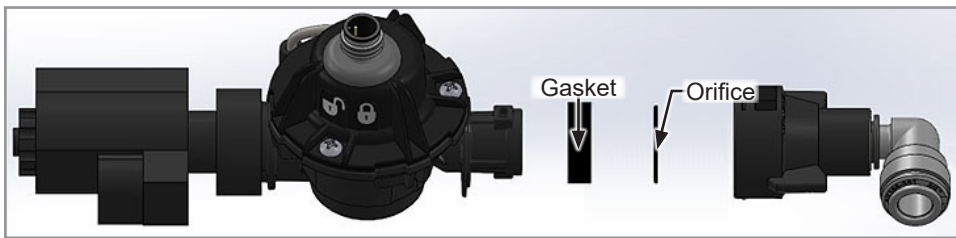

**NOTE: Orifices must be installed correctly. Install orifice with the blank side towards the flow meter manifold and the stamped side facing nozzle assembly (pointing downstream toward the direction of delivery).**

**NOTE: Orifice is installed in center groove of gasket.**

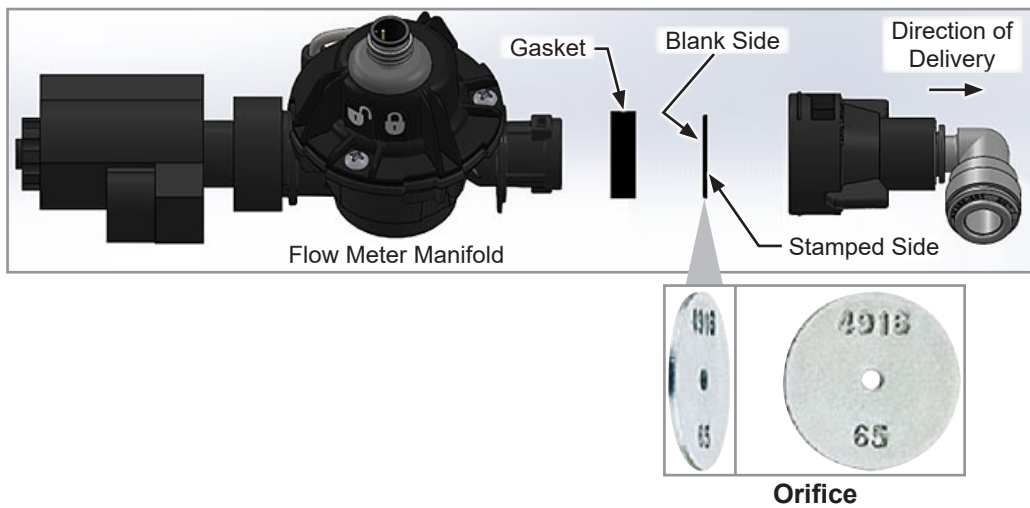

ORIFICE CONFIGURATION RATES

How to select an orifice configuration (using Orifice Look Up Chart below):

- Find the closest listed Liters per hectare [L/ha] value and its group of rows.

Identify the slowest and highest planting speed that will be used. Follow those rows over to corresponding row spacing being used, this equals Liters per minute [L/min].

- For a more accurate L/min value, use this formula: 
$$L/min = \frac{(Row\ Spacing\ (cm) \times km/h \times L/ha)}{60000}$$

- Take the low and high L/min values, trace them vertically on Orifice Rate Chart. Whichever bar best covers that range, this is the configuration that should be used.

**NOTE: If the L/min value is high enough, the jet orifice may have to be removed, see "[Row Flow Meter Jet Orifice Removal](#)" on [page 4-25](#).**

ORIFICE LOOK UP CHART

L/ha	km/h	70cm L/min	35cm L/min	L/ha	km/h	70cm L/min	35cm L/min	L/ha	km/h	70cm L/min	35cm L/min	L/ha	km/h	70cm L/min	35cm L/min
8	6	0.06	0.03	30	6	0.21	0.11	70	6	0.49	0.25	140	6	0.98	0.49
8	9	0.08	0.04	30	9	0.32	0.16	70	9	0.74	0.37	140	9	1.47	0.74
8	13	0.12	0.06	30	13	0.46	0.23	70	13	1.06	0.53	140	13	2.12	1.06
8	16	0.15	0.07	30	16	0.56	0.28	70	16	1.31	0.65	140	16	2.61	1.31
8	19	0.18	0.09	30	19	0.67	0.33	70	19	1.55	0.78	140	19	3.10	1.55
10	6	0.07	0.04	40	6	0.28	0.14	80	6	0.56	0.28	160	6	1.12	0.56
10	9	0.11	0.05	40	9	0.42	0.21	80	9	0.84	0.42	160	9	1.68	0.84
10	13	0.15	0.08	40	13	0.61	0.30	80	13	1.21	0.61	160	13	2.43	1.21
10	16	0.19	0.09	40	16	0.75	0.37	80	16	1.49	0.75	160	16	2.99	1.49
10	19	0.22	0.11	40	19	0.89	0.44	80	19	1.77	0.89	160	19	3.55	1.77
15	6	0.11	0.05	50	6	0.35	0.18	100	6	0.70	0.35	180	6	1.26	0.63
15	9	0.16	0.08	50	9	0.53	0.26	100	9	1.05	0.53	180	9	1.89	0.95
15	13	0.23	0.11	50	13	0.76	0.38	100	13	1.52	0.76	180	13	2.73	1.37
15	16	0.28	0.14	50	16	0.93	0.47	100	16	1.87	0.93	180	16	3.36	1.68
15	19	0.33	0.17	50	19	1.11	0.55	100	19	2.22	1.11	180	19	3.99	2.00
20	6	0.14	0.07	60	6	0.42	0.21	120	6	0.84	0.42	200	6	1.40	0.70
20	9	0.21	0.11	60	9	0.63	0.32	120	9	1.26	0.63	200	9	2.10	1.05
20	13	0.30	0.15	60	13	0.91	0.46	120	13	1.82	0.91	200	13	3.03	1.52
20	16	0.37	0.19	60	16	1.12	0.56	120	16	2.24	1.12	200	16	3.73	1.87
20	19	0.44	0.22	60	19	1.33	0.67	120	19	2.66	1.33	200	19	4.43	2.22

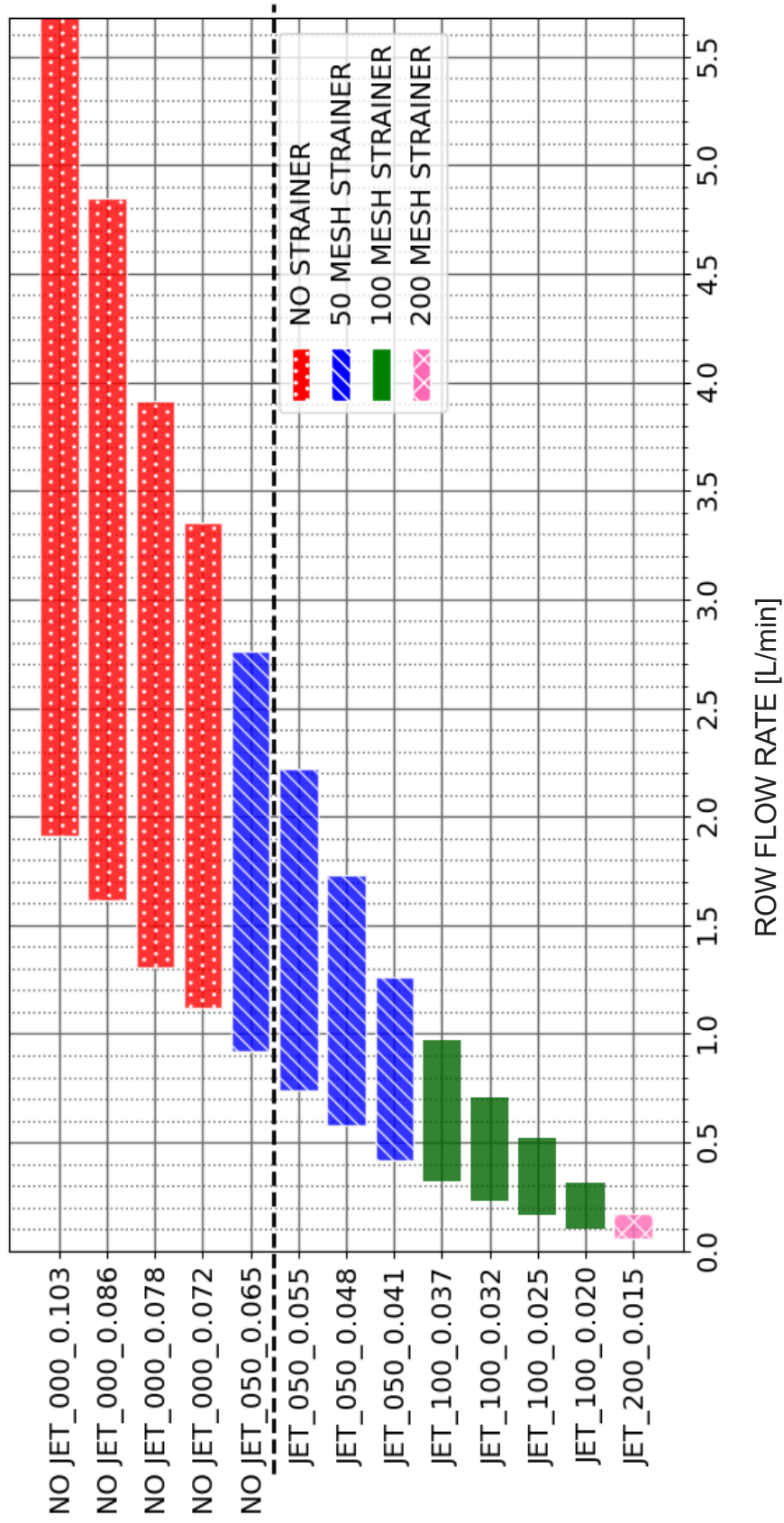

---

## PUMP CLEAN OUT AND STORAGE

**NOTE: Do not let fertilizer sit in the pump and system for longer than a day. Fertilizer will crystalize and cause issues with small moving parts and nozzles in the fertilizer system.**

**NOTE: Chemical solutions may become extremely corrosive if the system is not cleaned out properly.**

After each use, flush out the circuit with clean water by running the pump with clean water for a few minutes. Then drain it by operating without pressure and suck-in air opening a ball valve on the suction line or remove the suction fitting until the pump runs dry.

Inspect the pump and other circuit components with regularity, or at the end of the season, replacing any components that show signs of wear.

If the pump is stored for the winter in a zone with a risk of frost, liquid antifreeze should be added to the circuit flushing water.

1. Remove as much fertilizer out of the tank(s) and row unit manifolds as possible.
2. Fill the tanks with 300-500 liters of clean water.
3. Run system on Blue Vantage so that manual run buttons can be used to clean row unit plumbing.
4. Beginning in the middle of the planter, flushing each row unit (with manual run button) for 5-10 seconds each. Row unit is clean once mostly clear water is seen. After every row has been cleaned out, repeat process on each row for an additional 2-3 seconds per row. This will clean out the components on each row unit.
5. Clean the flow meters on every row. See ["Row Flow Meter Cleanout" on page 4-24](#).
6. Cleanout complete, complete remaining steps for winterization.

### Winterization

There are two methods for winterizing the pump, depending on whether ready-to-use antifreeze or antifreeze concentrate is used.

When ready-to-use anti-freeze is used:

1. Remove the suction hose barb. NOTE: The suction valve will be closed when not in a Blue Vantage task.
2. Remove the discharge manifold drain plug from the pump.

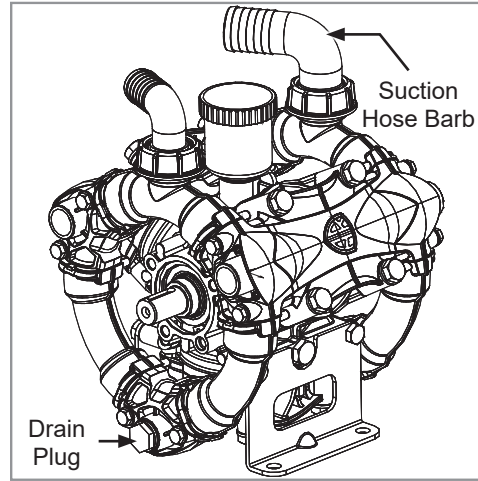

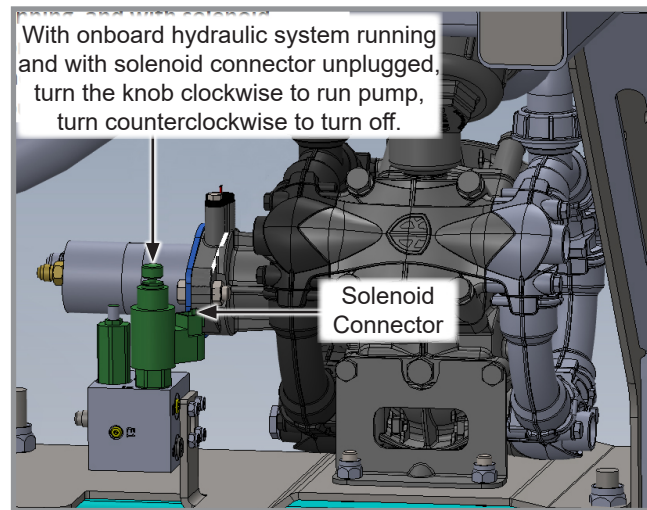

**Diaphragm Pump**

3. Turn the pump over by hand (or with the motor) for 15-20 seconds to remove any fluid in the manifolds and heads.



4. Reinstall the drain plug.
5. Add a 50:50 mix of water and antifreeze for fresh water systems (RV antifreeze) through the same inlet access port.
6. Run the pump for a few seconds to distribute the mix through the manifolds and heads.

7. Fill the onboard fertilizer tank with a small amount of liquid antifreeze for winter storage.

 <b>WARNING</b>	<b>Antifreeze can cause death or serious injury to persons, animals, and plants or seriously damage soil, equipment, or property. Read and follow all chemical manufacturers labels and instructions.</b>
	

8. Run the system so liquid antifreeze distributes through the manifolds and flow meter on every row unit. Use manual run buttons so antifreeze comes out of every row unit.

<b>NOTICE</b>	<b>Catch any antifreeze in a container and dispose in a safe manner, to appropriate waste disposal facility, in accordance with local/regional regulations.</b>
---------------	---

9. Wash any excess fertilizer or winterizing fluid off the planter before putting it into storage.

When antifreeze concentrate is used:

1. After the cleanout, there will be about 35 liters of water left in the system. Add the antifreeze concentrate into the L.H. fertilizer tank. Make sure to use the right ratio of the concentrate for your region.
2. Go into a planting task using Blue Vantage and leave the system to agitate for 5 minutes so the antifreeze can mix in the tank.
3. Flush the system using Blue Vantage for 2 minutes or until you see colored fluid coming out of fertilizer drop tubes.
4. Flush water remains from the quick-fill valve. Close the valve as soon as you see the antifreeze coming out.

## FERTILIZER PUMP FLUID DISCHARGE PROCEDURE

If it is needed to discharge the fluid from the fertilizer pump, remove the drain plug, turn the pump over, and remove the suction filter. Open the fill-up valve via Blue Vantage and discharge the fluid.

---

**IN FURROW**

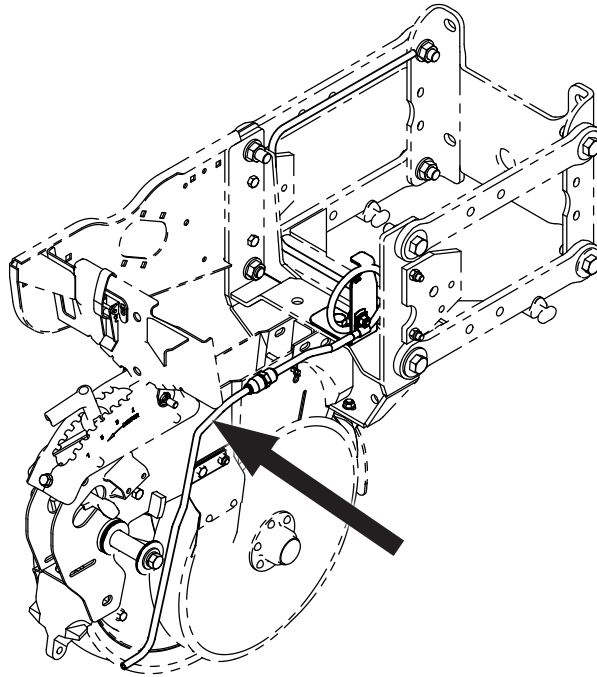

In Furrow is available for in-line installation to ensure equal distribution of product at low rates and siphon protection for field turns.



### LIQUID FERTILIZER 3-WAY DISTRIBUTION VALVES

The valve in the illustration below is used to control the fill-up flow. Operate the valve via the handle to set the flow to the desired fertilizer tank. The default handle position is in the middle and allows flow to both tanks.

For planting operations, turn the handle to its default position (indicated below).

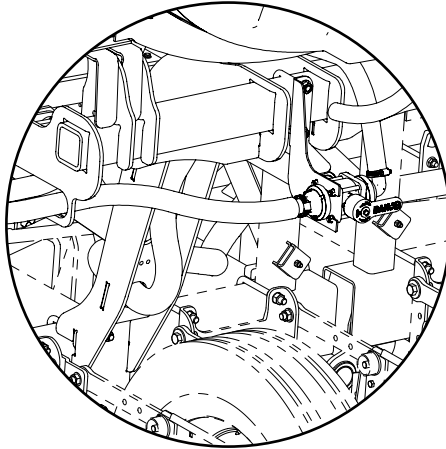

Valve location w/ Row Hoppers

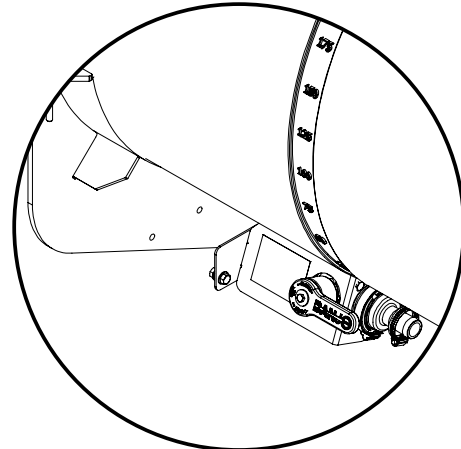

Valve location w/ Bulk Fill

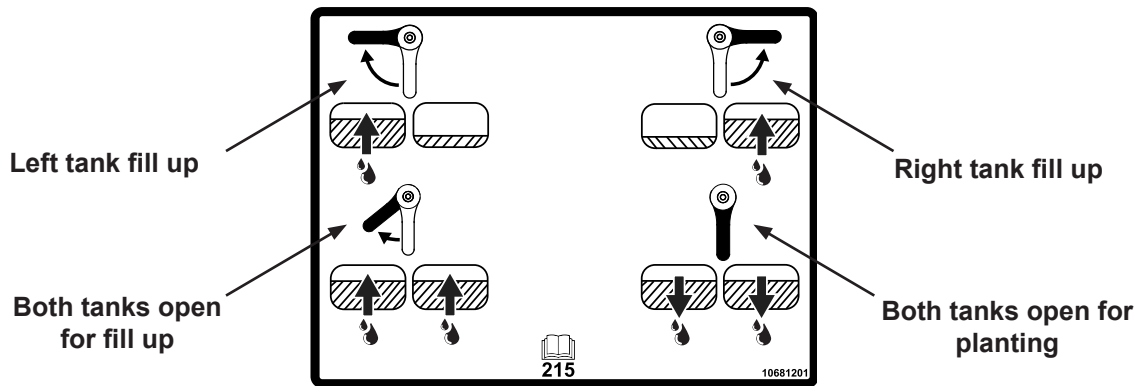

Valve functions for each handle position:



## LIQUID FERTILIZER SENSORS

Blue Vantage controlled liquid fertilizer system uses sensors to determine the level of liquid in the tanks and at the pump.

The sensors have a color LED which will inform the user about following:

-  Green - powered, no liquid detected.
-  Green & Orange - powered, liquid detected.



Sensor on fertilizer tank



Sensor at the pump flow line

**FERTILIZER PUMP TROUBLESHOOTING**

<b>PROBLEM</b>	<b>CAUSE</b>	<b>SOLUTION</b>
Pump does not prime.	Air being sucked in from suction line.	Check suction line connections and inspect it for damage.
	One or more valves not properly sealing.	Check the valves and replace them (if necessary).
Pump does not reach rated working pressure.	One or more valves not properly sealing.	Check the valves and replace them (if necessary).
	Nozzles worn or not correct diameter.	Check nozzles and replace them (if necessary).
	Suction filter plugged.	Clean filter.
	Presence of air pockets or collapsed suction hose.	Check suction line.
Pressure gauge needle fluctuates.	Air being sucked in from suction line.	Check suction line connections and inspect it for damages.
	One or more valves jammed.	Check the valves and replace them (if necessary).
Flow rate falls and pump is noisy.	Oil level in tank has dropped.	Top off oil to correct level.
Excessive noise and vibrations and fall in performance.	Cavitation.	Clean filter.
	Suction hose collapsed.	Check suction line and eliminate any restriction found.
	Suction filter plugged.	Clean filter or change filter cartridge.
Oil disappears from tank (after oil topped off)	One or more diaphragms are ruptured.	Stop pump immediately and replace diaphragm.
Oil going into tank changing to milky white color.	Oil/water emulsion into tank. One or more diaphragms are ruptured.	Stop pump immediately and replace diaphragm.

**FERTILIZER SYSTEM TROUBLESHOOTING**

<b>PROBLEM</b>	<b>CAUSE</b>	<b>SOLUTION</b>
Fertilizer flow not detected.	Plugged orifice.	Clean debris from orifice.
	Row shutoff valve plugged.	Clean debris from shutoff valve, replace if necessary.
	Flow meter plugged.	Open cover and check for debris.
Fertilizer flow unexpected.	Row shutoff valve stuck open.	Clean debris from shutoff valve, replace if necessary.
Fertilizer rail pressure high.	Improper orifice selection.	Refer to orifice charts.
	Check valve on agitation line installed backwards.	Turn valve around so flow arrow points out of regulator.
No fluid detected.	Fluid inlet sensor does not have power.	Check wiring harness.
	No fluid at pump.	Clean suction strainer regularly. Ensure fluid is in tanks, prime pump.
Fertilizer Off - rail sensor error.	Rail pressure sensor is not being powered properly.	Check wiring harness.
	Rail pressure sensor is damaged.	Replace pressure sensor.
Fertilizer Off - suction sensor error.	Suction pressure sensor is not being powered properly.	Check wiring harness.
	Suction pressure sensor is damaged.	Replace pressure sensor.
Fertilizer off - high suction pressure.	Suction pressure has exceeded -7 PSI (48 kPa).	Clean suction strainer regularly.
	Suction strainer is clogged.	
	Suction hose is kinked/damaged.	Replace hose.
	Electronic ball valve is not opening.	Check wiring harness and ball valve.
Pump RPM not detected.	RPM sensor is not being powered properly.	Check wiring harness.
Pump will not run or turn on.	No hydraulic flow to motor.	Send hydraulic flow to pump.
	No fertilizer control enabled.	Blue Vantage must be on and in a fertilizer task.
Pump will not prime or pump.	Plugged suction strainer.	Clean strainers regularly.
	Suction ball valve not opening.	Check wiring harness and ball valve.
Unable to achieve rate.	Plugged row strainers or orifice.	Inspect and clean row flow components.
	Plugged pressure strainer.	Clean strainers regularly.
Flow rate does not read properly below 1.5 GPM (6 L/min).	Lower small system flow meter installed backwards.	Ensure lower small system flow meter is in correct orientation (check arrow direction).
	Lower small system flow meter does not have power/reading incorrectly.	Check wiring harness.
Analog pressure gauge needle bouncing.	Inline orifice not installed in hose.	Add orifice to system before gauge.

---

## GENERAL PLANTING RATE INFORMATION

These planting rate charts apply to Kinze Model 3605 70 cm planters.

**NOTE: BULK FILL SYSTEM CANNOT BE USED WITH RAPESEED.**

### NOTICE

Sprocket combinations in these charts are for average conditions. Changes in sprocket combinations may be required for desired planting population. **ALWAYS MAKE FIELD CHECKS TO BE SURE YOU ARE PLANTING AT DESIRED RATE.**

NOTE: Seed size and shape may affect planting rate.

NOTE: Not all row spacings listed apply to all size planters.

NOTE: Speeds above 9 km/h can adversely affect seed spacing when planting with a True Speed planter.

NOTE: Planting rates over 672500 seeds/hectare are not recommended.

NOTE: Contact wheel drive sprocket references in each rate chart title.

NOTE: 22, 28, and 44 tooth drive sprockets are NOT applicable to all rate charts. Check chart titles to ensure proper rate chart is selected. 22 tooth sprocket requires 114 pitch No. 40 chain. 28 tooth sprocket requires 118 pitch No. 40 chain. 44 tooth sprocket requires 126 pitch No. 40 chain.

NOTE: DO NOT USE 44 tooth sprockets (60 cell soybean discs) with Dry Fertilizer Package or Liquid Fertilizer Package.

**PLANTING RATES FOR (VACUUM) CORN/SUNFLOWER 40 CELL DISC  
22 TOOTH CONTACT WHEEL DRIVE SPROCKET  
APPROXIMATE SEEDS/HECTARE FOR VARIOUS ROW WIDTHS**

70cm	Transmission Sprockets		Recomm. Speed (km/h)	Average Spacing (cm)
	Drive	Driven		
63720	15	28	6 to 10	22.4
66080	15	27	6 to 10	21.6
68621	15	26	6 to 10	20.8
71367	15	25	6 to 10	20.0
72217	17	28	6 to 10	19.8
74339	15	24	6 to 10	19.2
74892	17	27	6 to 10	19.1
77573	15	23	6 to 10	18.4
77771	17	26	6 to 10	18.4
80712	19	28	6 to 10	17.7
80881	17	25	6 to 10	17.7
83701	19	27	6 to 10	17.1
84252	17	24	6 to 10	17.0
86920	19	26	6 to 10	16.4
87915	17	23	6 to 10	16.2
90397	19	25	6 to 10	15.8
93903	15	19	6 to 10	15.2
94165	19	24	6 to 10	15.2
97705	23	28	6 to 10	14.6
98258	19	23	6 to 10	14.5
101323	23	27	6 to 10	14.1
101951	24	28	6 to 10	14.0
104951	15	17	6 to 10	13.6
105727	24	27	6 to 10	13.5
106423	17	19	6 to 10	13.4
109428	23	25	6 to 10	13.1
110449	26	28	6 to 10	12.9
113989	23	24	6 to 10	12.5
114186	24	25	6 to 10	12.5
114695	27	28	6 to 10	12.5
118944	23	23	6 to 10	12.0
123349	28	27	6 to 10	11.6
123520	27	26	6 to 10	11.6
124116	24	23	6 to 10	11.5
128094	28	26	6 to 10	11.2
128460	27	25	6 to 10	11.1
129288	25	23	6 to 10	11.0
132939	19	17	6 to 10	10.7
133812	27	24	6 to 10	10.7
134458	26	23	6 to 10	10.6
138767	28	24	6 to 10	10.3
139630	27	23	6 to 10	10.2
143985	23	19	6 to 10	9.9
144802	28	23	6 to 10	9.9
150245	24	19	6 to 10	9.5
156506	25	19	6 to 10	9.1
160924	23	17	6 to 10	8.9
162766	26	19	6 to 10	8.8
167921	24	17	6 to 10	8.5
169026	27	19	6 to 10	8.5
174918	25	17	6 to 10	8.2
175287	28	19	6 to 10	8.1
181916	26	17	6 to 10	7.9
182382	23	15	6 to 10	7.8
188911	27	17	6 to 10	7.6

**NOTE:** See "General Planting Rate Information" and "Checking Seed Population" (located in operator's manual) pages for additional information. Always check seed population in the field to ensure planting rates are correct.

**PLANTING RATES FOR (VACUUM) CORN/SUNFLOWER 40 CELL DISC  
28 TOOTH CONTACT WHEEL DRIVE SPROCKET  
APPROXIMATE SEEDS/HECTARE FOR VARIOUS ROW WIDTHS**

70cm	Transmission Sprockets		Recomm. Speed (km/h)	Average Spacing (cm)
	Drive	Driven		
81098	15	28	6 to 10	17.6
84102	15	27	6 to 10	17.0
87335	15	26	6 to 10	16.4
90831	15	25	6 to 10	15.7
91912	17	28	6 to 10	15.5
94613	15	24	6 to 10	15.1
95317	17	27	6 to 10	15.0
98730	15	23	6 to 10	14.5
98981	17	26	6 to 10	14.4
102725	19	28	6 to 10	13.9
102940	17	25	6 to 10	13.9
106529	19	27	6 to 10	13.4
107230	17	24	6 to 10	13.3
110626	19	26	6 to 10	12.9
111892	17	23	6 to 10	12.8
115051	19	25	6 to 10	12.4
119512	15	19	6 to 10	12.0
119846	19	24	6 to 10	11.9
124351	23	28	6 to 10	11.5
125055	19	23	6 to 10	11.4
128956	23	27	6 to 10	11.1
129756	24	28	6 to 10	11.0
133574	15	17	6 to 10	10.7
134562	24	27	6 to 10	10.6
135448	17	19	6 to 10	10.5
139272	23	25	6 to 10	10.3
140571	26	28	6 to 10	10.2
145076	23	24	6 to 10	9.8
145327	24	25	6 to 10	9.8
145976	27	28	6 to 10	9.8
151383	23	23	6 to 10	9.4
156989	28	27	6 to 10	9.1
157207	27	26	6 to 10	9.1
157966	24	23	6 to 10	9.0
163028	28	26	6 to 10	8.8
163495	27	25	6 to 10	8.7
164549	25	23	6 to 10	8.7
169194	19	17	6 to 10	8.4
170306	27	24	6 to 10	8.4
171128	26	23	6 to 10	8.3
176613	28	24	6 to 10	8.1
177711	27	23	6 to 10	8.0
183254	23	19	6 to 10	7.8
184294	28	23	6 to 10	7.8
191221	24	19	6 to 10	7.5
199189	25	19	6 to 10	7.2
204812	23	17	6 to 10	7.0
207157	26	19	6 to 10	6.9
213717	24	17	6 to 10	6.7
215125	27	19	6 to 10	6.6
222623	25	17	6 to 10	6.4
223092	28	19	6 to 10	6.4
231529	26	17	6 to 10	6.2
232122	23	15	6 to 10	6.2
240432	27	17	6 to 10	5.9

**NOTE: See "General Planting Rate Information" and "Checking Seed Population" (located in operator's manual) pages for additional information. Always check seed population in the field to ensure planting rates are correct.**

**PLANTING RATES FOR (VACUUM) MILO/SUGARBEET/SPECIALTY 60 CELL DISCS  
22 TOOTH CONTACT WHEEL DRIVE SPROCKET  
APPROXIMATE SEEDS/HECTARE FOR VARIOUS ROW WIDTHS**

35cm	70cm	Transmission Sprockets		Recomm. Speed (km/h)	Average Spacing (cm)
		Drive	Driven		
191160	95580	15	28	6 to 10	14.9
198240	99120	15	27	6 to 10	14.4
205865	102932	15	26	6 to 10	13.9
214099	107050	15	25	6 to 10	13.3
216648	108324	17	28	6 to 10	13.2
223020	111510	15	24	6 to 10	12.8
224672	112336	17	27	6 to 10	12.7
232717	116358	15	23	6 to 10	12.3
233314	116657	17	26	6 to 10	12.2
242136	121068	19	28	6 to 10	11.8
242646	121323	17	25	6 to 10	11.8
251104	125552	19	27	6 to 10	11.4
252756	126378	17	24	6 to 10	11.3
260762	130381	19	26	6 to 10	11.0
263746	131873	17	23	6 to 10	10.8
271193	135596	19	25	6 to 10	10.5
281710	140855	15	19	6 to 10	10.1
282492	141246	19	24	6 to 10	10.1
293112	146556	23	28	6 to 10	9.7
294775	147387	19	23	6 to 10	9.7
303968	151984	23	27	6 to 10	9.4
305856	152928	24	28	6 to 10	9.3
314852	157426	15	17	6 to 10	9.1
317184	158592	24	27	6 to 10	9.0
319271	159636	17	19	6 to 10	8.9
328286	164143	23	25	6 to 10	8.7
331344	165672	26	28	6 to 10	8.6
341964	170982	23	24	6 to 10	8.4
342559	171280	24	25	6 to 10	8.3
344088	172044	27	28	6 to 10	8.3
356832	178416	23	23	6 to 10	8.0
370049	185024	28	27	6 to 10	7.7
370557	185278	27	26	6 to 10	7.7
372347	186173	24	23	6 to 10	7.7
384281	192141	28	26	6 to 10	7.4
385379	192690	27	25	6 to 10	7.4
387861	193931	25	23	6 to 10	7.4
398813	199406	19	17	6 to 10	7.2
401437	200718	27	24	6 to 10	7.1
403376	201688	26	23	6 to 10	7.1
416305	208152	28	24	6 to 10	6.9
418890	209445	27	23	6 to 10	6.8
431955	215978	23	19	6 to 10	6.6
434405	217202	28	23	6 to 10	6.6
450736	225368	24	19	6 to 10	6.3
469516	234758	25	19	6 to 10	6.1
482773	241387	23	17	6 to 10	5.9
488297	244149	26	19	6 to 10	5.9
503764	251882	24	17	6 to 10	5.7
507078	253539	27	19	6 to 10	5.6
524754	262377	25	17	6 to 10	5.4
525858	262929	28	19	6 to 10	5.4
545744	272872	26	17	6 to 10	5.2
547143	273572	23	15	6 to 10	5.2
566734	283367	27	17	6 to 10	5.0

**NOTE: See "General Planting Rate Information" and "Checking Seed Population" (located in operator's manual) pages for additional information. Always check seed population in the field to ensure planting rates are correct.**



**PLANTING RATES FOR (VACUUM) MILO/SUGAR BEET/SPECIALTY 60 CELL  
28 TOOTH CONTACT WHEEL DRIVE SPROCKET  
APPROXIMATE SEEDS/HECTARE FOR VARIOUS ROW WIDTHS**

35cm	70cm	Transmission Sprockets		Recomm. Speed (km/h)	Average Spacing (cm)
		Drive	Driven		
243295	121647	15	28	6 to 10	11.7
252306	126153	15	27	6 to 10	11.3
262010	131005	15	26	6 to 10	10.9
272490	136245	15	25	6 to 10	10.5
275734	137867	17	28	6 to 10	10.4
283844	141922	15	24	6 to 10	10.1
285947	142973	17	27	6 to 10	10.0
296185	148093	15	23	6 to 10	9.6
296945	148472	17	26	6 to 10	9.6
308174	154087	19	28	6 to 10	9.3
308822	154411	17	25	6 to 10	9.3
319587	159794	19	27	6 to 10	8.9
321690	160845	17	24	6 to 10	8.9
331879	165940	19	26	6 to 10	8.6
335676	167838	17	23	6 to 10	8.5
345154	172577	19	25	6 to 10	8.3
358540	179270	15	19	6 to 10	8.0
359536	179768	19	24	6 to 10	7.9
373052	186526	23	28	6 to 10	7.7
375168	187584	19	23	6 to 10	7.6
386869	193434	23	27	6 to 10	7.4
389272	194636	24	28	6 to 10	7.3
400721	200360	15	17	6 to 10	7.1
403689	201845	24	27	6 to 10	7.1
406345	203173	17	19	6 to 10	7.0
417818	208909	23	25	6 to 10	6.8
421711	210856	26	28	6 to 10	6.8
435228	217614	23	24	6 to 10	6.6
435984	217992	24	25	6 to 10	6.6
437931	218965	27	28	6 to 10	6.5
454150	227075	23	23	6 to 10	6.3
470971	235485	28	27	6 to 10	6.1
471618	235809	27	26	6 to 10	6.1
473896	236948	24	23	6 to 10	6.0
489085	244543	28	26	6 to 10	5.8
490482	245241	27	25	6 to 10	5.8
493642	246821	25	23	6 to 10	5.8
507580	253790	19	17	6 to 10	5.6
510919	255460	27	24	6 to 10	5.6
513387	256694	26	23	6 to 10	5.6
529842	264921	28	24	6 to 10	5.4
533133	266567	27	23	6 to 10	5.4
549761	274881	23	19	6 to 10	5.2
552879	276439	28	23	6 to 10	5.2
573664	286832	24	19	6 to 10	5.0
597566	298783	25	19	6 to 10	4.8
614439	307219	23	17	6 to 10	4.7
621469	310735	26	19	6 to 10	4.6
641154	320577	24	17	6 to 10	4.5
645372	322686	27	19	6 to 10	4.4
667868	333934	25	17	6 to 10	4.3
669274	334637	28	19	6 to 10	4.3
	347292	26	17	6 to 10	4.1
	348182	23	15	6 to 10	4.1
	360649	27	17	6 to 10	4.0

**NOTE: See "General Planting Rate Information" and "Checking Seed Population" (located in operator's manual) pages for additional information. Always check seed population in the field to ensure planting rates are correct.**

**PLANTING RATES FOR (VACUUM) MILO/SUGARBEET/SPECIALTY 60 CELL DISCS  
15 TOOTH CONTACT WHEEL DRIVE SPROCKET  
APPROXIMATE SEEDS/HECTARE FOR VARIOUS ROW WIDTHS**

35cm	70cm	Transmission Sprockets		Recomm. Speed (km/h)	Average Spacing (cm)
		Drive	Driven		
130336	65168	15	28	6 to 10	21.9
135164	67582	15	27	6 to 10	21.1
140363	70181	15	26	6 to 10	20.4
145977	72988	15	25	6 to 10	19.6
147715	73857	17	28	6 to 10	19.3
152059	76030	15	24	6 to 10	18.8
153185	76593	17	27	6 to 10	18.7
158671	79335	15	23	6 to 10	18.0
159078	79539	17	26	6 to 10	18.0
165093	82546	19	28	6 to 10	17.3
165440	82720	17	25	6 to 10	17.3
171207	85604	19	27	6 to 10	16.7
172334	86167	17	24	6 to 10	16.6
177792	88896	19	26	6 to 10	16.1
179827	89913	17	23	6 to 10	15.9
184904	92452	19	25	6 to 10	15.5
192075	96038	15	19	6 to 10	14.9
192608	96304	19	24	6 to 10	14.8
199849	99925	23	28	6 to 10	14.3
200983	100491	19	23	6 to 10	14.2
207251	103625	23	27	6 to 10	13.8
208538	104269	24	28	6 to 10	13.7
214672	107336	15	17	6 to 10	13.3
216262	108131	24	27	6 to 10	13.2
217685	108842	17	19	6 to 10	13.1
223831	111916	23	25	6 to 10	12.8
225916	112958	26	28	6 to 10	12.6
233157	116579	23	24	6 to 10	12.3
233563	116781	24	25	6 to 10	12.2
234605	117303	27	28	6 to 10	12.2
243295	121647	23	23	6 to 10	11.7
252306	126153	28	27	6 to 10	11.3
252653	126326	27	26	6 to 10	11.3
253873	126936	24	23	6 to 10	11.3
262010	131005	28	26	6 to 10	10.9
262758	131379	27	25	6 to 10	10.9
264451	132225	25	23	6 to 10	10.8
271918	135959	19	17	6 to 10	10.5
273707	136854	27	24	6 to 10	10.4
275029	137515	26	23	6 to 10	10.4
283844	141922	28	24	6 to 10	10.1
285607	142803	27	23	6 to 10	10.0
294515	147257	23	19	6 to 10	9.7
296185	148093	28	23	6 to 10	9.6
307320	153660	24	19	6 to 10	9.3
320125	160062	25	19	6 to 10	8.9
329163	164582	23	17	6 to 10	8.7
332930	166465	26	19	6 to 10	8.6
343475	171738	24	17	6 to 10	8.3
345735	172868	27	19	6 to 10	8.3
357787	178893	25	17	6 to 10	8.0
358540	179270	28	19	6 to 10	8.0
372098	186049	26	17	6 to 10	7.7
373052	186526	23	15	6 to 10	7.7
386410	193205	27	17	6 to 10	7.4

**NOTE:** See "General Planting Rate Information" and "Checking Seed Population" (located in operator's manual) pages for additional information. Always check seed population in the field to ensure planting rates are correct.

**PLANTING RATES FOR (VACUUM) MILO/SUGARBEET/SPECIALTY 60 CELL DISCS  
17 TOOTH CONTACT WHEEL DRIVE SPROCKET  
APPROXIMATE SEEDS/HECTARE FOR VARIOUS ROW WIDTHS**

35cm	70cm	Transmission Sprockets		Recomm. Speed (km/h)	Average Spacing (cm)
		Drive	Driven		
147715	73857	15	28	6 to 10	19.3
153185	76593	15	27	6 to 10	18.7
159078	79539	15	26	6 to 10	18.0
165440	82720	15	25	6 to 10	17.3
167410	83705	17	28	6 to 10	17.1
172334	86167	15	24	6 to 10	16.6
173610	86805	17	27	6 to 10	16.5
179827	89913	15	23	6 to 10	15.9
180288	90144	17	26	6 to 10	15.8
187105	93553	19	28	6 to 10	15.3
187499	93750	17	25	6 to 10	15.2
194035	97017	19	27	6 to 10	14.7
195311	97656	17	24	6 to 10	14.6
201498	100749	19	26	6 to 10	14.2
203804	101902	17	23	6 to 10	14.0
209558	104779	19	25	6 to 10	13.6
217685	108843	15	19	6 to 10	13.1
218289	109145	19	24	6 to 10	13.1
226496	113248	23	28	6 to 10	12.6
227781	113890	19	23	6 to 10	12.5
234884	117442	23	27	6 to 10	12.2
236343	118172	24	28	6 to 10	12.1
243295	121647	15	17	6 to 10	11.7
245097	122548	24	27	6 to 10	11.7
246709	123355	17	19	6 to 10	11.6
253676	126838	23	25	6 to 10	11.3
256039	128019	26	28	6 to 10	11.2
264245	132122	23	24	6 to 10	10.8
264705	132352	24	25	6 to 10	10.8
265886	132943	27	28	6 to 10	10.7
275734	137867	23	23	6 to 10	10.4
285947	142973	28	27	6 to 10	10.0
286340	143170	27	26	6 to 10	10.0
287723	143861	24	23	6 to 10	9.9
296944	148472	28	26	6 to 10	9.6
297793	148896	27	25	6 to 10	9.6
299711	149855	25	23	6 to 10	9.5
308174	154087	19	17	6 to 10	9.3
310201	155101	27	24	6 to 10	9.2
311700	155850	26	23	6 to 10	9.2
321690	160845	28	24	6 to 10	8.9
323688	161844	27	23	6 to 10	8.8
333783	166892	23	19	6 to 10	8.6
335677	167838	28	23	6 to 10	8.5
348296	174148	24	19	6 to 10	8.2
362808	181404	25	19	6 to 10	7.9
373052	186526	23	17	6 to 10	7.7
377320	188660	26	19	6 to 10	7.6
389272	194636	24	17	6 to 10	7.3
391833	195917	27	19	6 to 10	7.3
405492	202746	25	17	6 to 10	7.0
406345	203172	28	19	6 to 10	7.0
421711	210856	26	17	6 to 10	6.8
422792	211396	23	15	6 to 10	6.8
437931	218965	27	17	6 to 10	6.5

**NOTE: See "General Planting Rate Information" and "Checking Seed Population" (located in operator's manual) pages for additional information. Always check seed population in the field to ensure planting rates are correct.**

**PLANTING RATES FOR (VACUUM) MILO/SUGARBEET/SPECIALTY 60 CELL DISCS  
19 TOOTH CONTACT WHEEL DRIVE SPROCKET  
APPROXIMATE SEEDS/HECTARE FOR VARIOUS ROW WIDTHS**

35cm	70cm	Transmission Sprockets		Recomm. Speed (km/h)	Average Spacing (cm)
		Drive	Driven		
165093	82546	15	28	6 to 10	17.3
171207	85604	15	27	6 to 10	16.7
177793	88896	15	26	6 to 10	16.1
184904	92452	15	25	6 to 10	15.5
187105	93553	17	28	6 to 10	15.3
192608	96304	15	24	6 to 10	14.8
194035	97017	17	27	6 to 10	14.7
200983	100491	15	23	6 to 10	14.2
201498	100749	17	26	6 to 10	14.2
209117	104559	19	28	6 to 10	13.7
209558	104779	17	25	6 to 10	13.6
216863	108431	19	27	6 to 10	13.2
218289	109145	17	24	6 to 10	13.1
225204	112602	19	26	6 to 10	12.7
227781	113890	17	23	6 to 10	12.5
234212	117106	19	25	6 to 10	12.2
243295	121648	15	19	6 to 10	11.7
243970	121985	19	24	6 to 10	11.7
253142	126571	23	28	6 to 10	11.3
254578	127289	19	23	6 to 10	11.2
262518	131259	23	27	6 to 10	10.9
264148	132074	24	28	6 to 10	10.8
271918	135959	15	17	6 to 10	10.5
273932	136966	24	27	6 to 10	10.4
275734	137867	17	19	6 to 10	10.4
283520	141760	23	25	6 to 10	10.1
286161	143080	26	28	6 to 10	10.0
295333	147666	23	24	6 to 10	9.7
295846	147923	24	25	6 to 10	9.7
297167	148583	27	28	6 to 10	9.6
308173	154087	23	23	6 to 10	9.3
319588	159794	28	27	6 to 10	8.9
320027	160013	27	26	6 to 10	8.9
321572	160786	24	23	6 to 10	8.9
331879	165940	28	26	6 to 10	8.6
332827	166414	27	25	6 to 10	8.6
334971	167485	25	23	6 to 10	8.5
344429	172215	19	17	6 to 10	8.3
346696	173348	27	24	6 to 10	8.2
348370	174185	26	23	6 to 10	8.2
359536	179768	28	24	6 to 10	7.9
361769	180884	27	23	6 to 10	7.9
373052	186526	23	19	6 to 10	7.7
375168	187584	28	23	6 to 10	7.6
389272	194636	24	19	6 to 10	7.3
405491	202746	25	19	6 to 10	7.0
416940	208470	23	17	6 to 10	6.9
421711	210856	26	19	6 to 10	6.8
435069	217534	24	17	6 to 10	6.6
437931	218966	27	19	6 to 10	6.5
453197	226598	25	17	6 to 10	6.3
454150	227075	28	19	6 to 10	6.3
471324	235662	26	17	6 to 10	6.1
472533	236266	23	15	6 to 10	6.0
489452	244726	27	17	6 to 10	5.8

**NOTE: See "General Planting Rate Information" and "Checking Seed Population" (located in operator's manual) pages for additional information. Always check seed population in the field to ensure planting rates are correct.**

**This page left blank intentionally.**

**PLANTING RATES FOR (VACUUM) SPECIALTY 60 CELL DISC  
44 TOOTH CONTACT WHEEL DRIVE SPROCKET  
APPROXIMATE SEEDS/HECTARE FOR VARIOUS ROW WIDTHS**

35cm	70cm	Transmission Sprockets		Recomm. Speed (km/h)	Average Spacing (cm)
		Drive	Driven		
382321	191160	15	28	6 to 10	7.5
396481	198240	15	27	6 to 10	7.2
411730	205865	15	26	6 to 10	6.9
428199	214099	15	25	6 to 10	6.7
433297	216648	17	28	6 to 10	6.6
446041	223020	15	24	6 to 10	6.4
449345	224672	17	27	6 to 10	6.4
465434	232717	15	23	6 to 10	6.1
466627	233314	17	26	6 to 10	6.1
484273	242136	19	28	6 to 10	5.9
485292	242646	17	25	6 to 10	5.9
502209	251104	19	27	6 to 10	5.7
505513	252756	17	24	6 to 10	5.7
521524	260762	19	26	6 to 10	5.5
527492	263746	17	23	6 to 10	5.4
542385	271193	19	25	6 to 10	5.3
563420	281710	15	19	6 to 10	5.1
564985	282492	19	24	6 to 10	5.1
586225	293112	23	28	6 to 10	4.9
589549	294775	19	23	6 to 10	4.8
607937	303968	23	27	6 to 10	4.7
611713	305856	24	28	6 to 10	4.7
629704	314852	15	17	6 to 10	4.5
634369	317184	24	27	6 to 10	4.5
638542	319271	17	19	6 to 10	4.5
656572	328286	23	25	6 to 10	4.4
662689	331344	26	28	6 to 10	4.3
	341964	23	24	6 to 10	4.2
	342559	24	25	6 to 10	4.2
	344088	27	28	6 to 10	4.2
	356832	23	23	6 to 10	4.0
	370049	28	27	6 to 10	3.9
	370557	27	26	6 to 10	3.9
	372347	24	23	6 to 10	3.8
	384281	28	26	6 to 10	3.7
	385379	27	25	6 to 10	3.7
	387861	25	23	6 to 10	3.7
	398813	19	17	6 to 10	3.6
	401437	27	24	6 to 10	3.6
	403376	26	23	6 to 10	3.5
	416305	28	24	6 to 10	3.4
	418890	27	23	6 to 10	3.4
	431955	23	19	6 to 10	3.3
	434405	28	23	6 to 10	3.3
	450736	24	19	6 to 10	3.2
	469516	25	19	6 to 10	3.0
	482773	23	17	6 to 10	3.0
	488297	26	19	6 to 10	2.9
	503764	24	17	6 to 10	2.8
	507078	27	19	6 to 10	2.8
	524754	25	17	6 to 10	2.7
	525858	28	19	6 to 10	2.7
	545744	26	17	6 to 10	2.6
	547143	23	15	6 to 10	2.6
	566734	27	17	6 to 10	2.5

**NOTE: See "General Planting Rate Information" and "Checking Seed Population" (located in operator's manual) pages for additional information. Always check seed population in the field to ensure planting rates are correct.**

**PLANTING RATES FOR (VACUUM) SOYBEAN 120 CELL DISC  
22 TOOTH CONTACT WHEEL DRIVE SPROCKET  
APPROXIMATE SEEDS/HECTARE FOR VARIOUS ROW WIDTHS**

35cm	70cm	Transmission Sprockets		Recomm. Speed (km/h)	Average Spacing (cm)
		Drive	Driven		
382321	191160	15	28	6 to 10	7.5
396481	198240	15	27	6 to 10	7.2
411730	205865	15	26	6 to 10	6.9
428199	214099	15	25	6 to 10	6.7
433297	216648	17	28	6 to 10	6.6
446041	223020	15	24	6 to 10	6.4
449345	224672	17	27	6 to 10	6.4
465434	232717	15	23	6 to 10	6.1
466627	233314	17	26	6 to 10	6.1
484273	242136	19	28	6 to 10	5.9
485292	242646	17	25	6 to 10	5.9
502209	251104	19	27	6 to 10	5.7
505513	252756	17	24	6 to 10	5.7
521524	260762	19	26	6 to 10	5.5
527492	263746	17	23	6 to 10	5.4
542385	271193	19	25	6 to 10	5.3
563420	281710	15	19	6 to 10	5.1
564985	282492	19	24	6 to 10	5.1
586225	293112	23	28	6 to 10	4.9
589549	294775	19	23	6 to 10	4.8
607937	303968	23	27	6 to 10	4.7
611713	305856	24	28	6 to 10	4.7
629704	314852	15	17	6 to 10	4.5
634369	317184	24	27	6 to 10	4.5
638542	319271	17	19	6 to 10	4.5
656572	328286	23	25	6 to 10	4.4
662689	331344	26	28	6 to 10	4.3
	341964	23	24	6 to 10	4.2
	342559	24	25	6 to 10	4.2
	344088	27	28	6 to 10	4.2
	356832	23	23	6 to 10	4.0
	370049	28	27	6 to 10	3.9
	370557	27	26	6 to 10	3.9
	372347	24	23	6 to 10	3.8
	384281	28	26	6 to 10	3.7
	385379	27	25	6 to 10	3.7
	387861	25	23	6 to 10	3.7
	398813	19	17	6 to 10	3.6
	401437	27	24	6 to 10	3.6
	403376	26	23	6 to 10	3.5
	416305	28	24	6 to 10	3.4
	418890	27	23	6 to 10	3.4
	431955	23	19	6 to 10	3.3
	434405	28	23	6 to 10	3.3
	450736	24	19	6 to 10	3.2
	469516	25	19	6 to 10	3.0
	482773	23	17	6 to 10	3.0
	488297	26	19	6 to 10	2.9
	503764	24	17	6 to 10	2.8
	507078	27	19	6 to 10	2.8
	524754	25	17	6 to 10	2.7
	525858	28	19	6 to 10	2.7
	545744	26	17	6 to 10	2.6
	547143	23	15	6 to 10	2.6
	566734	27	17	6 to 10	2.5

**NOTE:** See "General Planting Rate Information" and "Checking Seed Population" (located in operator's manual) pages for additional information. Always check seed population in the field to ensure planting rates are correct.

**PLANTING RATES FOR (VACUUM) SOYBEAN 120 CELL DISC  
28 TOOTH CONTACT WHEEL DRIVE SPROCKET  
APPROXIMATE SEEDS/HECTARE FOR VARIOUS ROW WIDTHS**

35cm	70cm	Transmission Sprockets		Recomm. Speed (km/h)	Average Spacing (cm)
		Drive	Driven		
486590	243295	15	28	6 to 10	5.9
504612	252306	15	27	6 to 10	5.7
524020	262010	15	26	6 to 10	5.5
544981	272490	15	25	6 to 10	5.2
551468	275734	17	28	6 to 10	5.2
567688	283844	15	24	6 to 10	5.0
571893	285947	17	27	6 to 10	5.0
592370	296185	15	23	6 to 10	4.8
593889	296945	17	26	6 to 10	4.8
616347	308174	19	28	6 to 10	4.6
617645	308822	17	25	6 to 10	4.6
639175	319587	19	27	6 to 10	4.5
643380	321690	17	24	6 to 10	4.4
663758	331879	19	26	6 to 10	4.3
671353	335676	17	23	6 to 10	4.3
	345154	19	25	6 to 10	4.1
	358540	15	19	6 to 10	4.0
	359536	19	24	6 to 10	4.0
	373052	23	28	6 to 10	3.8
	375168	19	23	6 to 10	3.8
	386869	23	27	6 to 10	3.7
	389272	24	28	6 to 10	3.7
	400721	15	17	6 to 10	3.6
	403689	24	27	6 to 10	3.5
	406345	17	19	6 to 10	3.5
	417818	23	25	6 to 10	3.4
	421711	26	28	6 to 10	3.4
	435228	23	24	6 to 10	3.3
	435984	24	25	6 to 10	3.3
	437931	27	28	6 to 10	3.3
	454150	23	23	6 to 10	3.1
	470971	28	27	6 to 10	3.0
	471618	27	26	6 to 10	3.0
	473896	24	23	6 to 10	3.0
	489085	28	26	6 to 10	2.9
	490482	27	25	6 to 10	2.9
	493642	25	23	6 to 10	2.9
	507580	19	17	6 to 10	2.8
	510919	27	24	6 to 10	2.8
	513387	26	23	6 to 10	2.8
	529842	28	24	6 to 10	2.7
	533133	27	23	6 to 10	2.7
	549761	23	19	6 to 10	2.6
	552879	28	23	6 to 10	2.6
	573664	24	19	6 to 10	2.5
	597566	25	19	6 to 10	2.4
	614439	23	17	6 to 10	2.3
	621469	26	19	6 to 10	2.3
	641154	24	17	6 to 10	2.2
	645372	27	19	6 to 10	2.2
	667868	25	17	6 to 10	2.1
	669274	28	19	6 to 10	2.1

**NOTE: See "General Planting Rate Information" and "Checking Seed Population" (located in operator's manual) pages for additional information. Always check seed population in the field to ensure planting rates are correct.**



**PLANTING RATES FOR (VACUUM) RAPESEED 83 CELL DISC  
22 TOOTH CONTACT WHEEL DRIVE SPROCKET  
APPROXIMATE SEEDS/HECTARE FOR VARIOUS ROW WIDTHS**

35cm	Transmission Sprockets		Recomm. Speed (km/h)	Average Spacing (cm)
	Drive	Driven		
349646	17	24	6 to 10	8.2
360721	19	26	6 to 10	7.9
364849	17	23	6 to 10	7.8
375149	19	25	6 to 10	7.6
389699	15	19	6 to 10	7.3
390781	19	24	6 to 10	7.3
405472	23	28	6 to 10	7.0
407771	19	23	6 to 10	7.0
420489	23	27	6 to 10	6.8
423101	24	28	6 to 10	6.8
435545	15	17	6 to 10	6.6
438771	24	27	6 to 10	6.5
441660	17	19	6 to 10	6.5
454129	23	25	6 to 10	6.3
458359	26	28	6 to 10	6.2
473050	23	24	6 to 10	6.0
473875	24	25	6 to 10	6.0
475988	27	28	6 to 10	6.0
493618	23	23	6 to 10	5.8
511900	28	27	6 to 10	5.6
512602	27	26	6 to 10	5.6
515079	24	23	6 to 10	5.5
531590	28	26	6 to 10	5.4
533109	27	25	6 to 10	5.4
536542	25	23	6 to 10	5.3
551690	19	17	6 to 10	5.2
555320	27	24	6 to 10	5.1
558003	26	23	6 to 10	5.1
575887	28	24	6 to 10	5.0
579465	27	23	6 to 10	4.9
597539	23	19	6 to 10	4.8
600926	28	23	6 to 10	4.8
623518	24	19	6 to 10	4.6
649497	25	19	6 to 10	4.4
667837	23	17	6 to 10	4.3
675479	26	19	6 to 10	4.2
696874	24	17	6 to 10	4.1
701458	27	19	6 to 10	4.1
725910	25	17	6 to 10	3.9
727437	28	19	6 to 10	3.9
754946	26	17	6 to 10	3.8
756883	23	15	6 to 10	3.8
783982	27	17	6 to 10	3.6

**NOTE:** See "General Planting Rate Information" and "Checking Seed Population" (located in operator's manual) pages for additional information. Always check seed population in the field to ensure planting rates are correct.

**PLANTING RATES FOR (VACUUM) RAPESEED 83 CELL DISC  
28 TOOTH CONTACT WHEEL DRIVE SPROCKET  
APPROXIMATE SEEDS/HECTARE FOR VARIOUS ROW WIDTHS**

35cm	Transmission Sprockets		Recomm. Speed (km/h)	Average Spacing (cm)
	Drive	Driven		
349023	15	27	6 to 10	8.2
362447	15	26	6 to 10	7.9
376945	15	25	6 to 10	7.6
381432	17	28	6 to 10	7.5
392651	15	24	6 to 10	7.3
395559	17	27	6 to 10	7.2
409724	15	23	6 to 10	7.0
410773	17	26	6 to 10	7.0
426307	19	28	6 to 10	6.7
427204	17	25	6 to 10	6.7
442097	19	27	6 to 10	6.5
445005	17	24	6 to 10	6.4
459101	19	26	6 to 10	6.2
464352	17	23	6 to 10	6.2
477463	19	25	6 to 10	6.0
495980	15	19	6 to 10	5.8
497358	19	24	6 to 10	5.7
516055	23	28	6 to 10	5.5
518982	19	23	6 to 10	5.5
535167	23	27	6 to 10	5.3
538493	24	28	6 to 10	5.3
554329	15	17	6 to 10	5.2
558438	24	27	6 to 10	5.1
562112	17	19	6 to 10	5.1
577982	23	25	6 to 10	4.9
583368	26	28	6 to 10	4.9
602065	23	24	6 to 10	4.7
603111	24	25	6 to 10	4.7
605803	27	28	6 to 10	4.7
628241	23	23	6 to 10	4.5
651509	28	27	6 to 10	4.4
652405	27	26	6 to 10	4.4
655556	24	23	6 to 10	4.4
676569	28	26	6 to 10	4.2
678500	27	25	6 to 10	4.2
682871	25	23	6 to 10	4.2
702152	19	17	6 to 10	4.1
706773	27	24	6 to 10	4.0
710187	26	23	6 to 10	4.0
732948	28	24	6 to 10	3.9
737502	27	23	6 to 10	3.9
760504	23	19	6 to 10	3.8
764815	28	23	6 to 10	3.7
793569	24	19	6 to 10	3.6
826633	25	19	6 to 10	3.5

**NOTE:** See “General Planting Rate Information” and “Checking Seed Population” (located in operator’s manual) pages for additional information. Always check seed population in the field to ensure planting rates are correct.

**DRY FERTILIZER APPLICATION RATES (VACUUM)  
22 TOOTH CONTACT WHEEL DRIVE SPROCKET  
APPROXIMATE RATE IN KILOGRAMS PER HECTARE**

Drive Sprocket	Driven Sprocket	Low Rate Position	High Rate Position
		70cm Rows	70cm Rows
15	35	35	105
15	33	40	120
15	30	44	133
19	33	50	151
19	30	55	168
15	19	63	193
30	35	68	210
30	33	73	222
33	35	77	231
35	33	85	259
33	30	89	268
19	15	102	332
30	19	127	386
33	19	140	423
35	19	149	449
30	15	161	488
33	15	176	537
35	15	188	570

See notes on following page.

**DRY FERTILIZER APPLICATION RATES (VACUUM)  
28 TOOTH CONTACT WHEEL DRIVE SPROCKET  
APPROXIMATE RATE IN KILOGRAMS PER HECTARE**

Drive Sprocket	Driven Sprocket	Low Rate Position	High Rate Position
		70cm Rows	70cm Rows
15	35	45	133
15	33	51	151
15	30	56	168
19	33	63	192
19	30	70	214
15	19	81	244
30	35	87	266
30	33	93	282
33	35	98	292
35	33	109	328
33	30	112	340
19	15	129	421
30	19	161	488
33	19	178	537
35	19	189	569
30	15	204	619
33	15	225	680
35	15	238	722

**NOTE: (VACUUM ONLY) 22, 28 and 44 tooth drive sprockets are NOT applicable to all rate charts. Check title to ensure proper rate chart is selected. DO NOT USE 44 tooth drive sprockets (60 cell soybean discs) with Dry Fertilizer Package.**

**NOTE: Uneven delivery may result from attempting to use rates lower than indicated by chart.**

Direction  
Of Rotation



High Rate Position



Low Rate Position

Chart is for planters equipped with contact drive. See "Tire Pressure" for recommended tire pressures.

Chart calculated with a bulk density of 1.04 kg per liter.

**NOTE: Fertilizer application rates can vary from weights calculated in chart. Make field checks to be sure you are applying fertilizer at desired rate.**

**NOTE: Optional two-speed point row clutch is located ahead of dry fertilizer drive. Activating two-speed point row clutch reduced rate switch will cause same percent of reduction in dry fertilizer application rates.**

To check exact number of kilograms your fertilizer attachment actually delivers on a 70 cm row spacing, remove one spout from one fertilizer hopper and attach a container under opening. Engage fertilizer attachment and drive forward for 47.6 m. Weigh amount of fertilizer caught in container and multiply that by 300. Result is kilograms of fertilizer per hectare when planting in 70 cm rows.

## LIQUID FERTILIZER PISTON PUMP APPLICATION RATES LITERS PER HECTARE

**Applies To Model NGP-7055 Pumps With 18 Tooth Sprocket  
And 7.60" x 15" Ground Drive Tire**

Pump Setting	2	3	4	5	6	7	8	9	10
12 Row 70cm	75.2	112.8	150.4	188.0	224.6	262.2	299.8	337.4	375.0
16 Row 70cm	56.0	84.5	113.0	141.5	169.0	197.5	226.0	253.5	282.0

Chart is for planters equipped with 7.60" x 15" ground drive tire, based on 2.3 meters forward travel per wheel revolution, 48 tooth drive sprocket and 18 tooth driven sprocket on metering pump. Check tires for correct operating pressure.

Chart calculated based on a solution weighing 1.2 kilograms per liter.

**NOTE: Fertilizer application rates can vary from weights calculated in above chart. Make field checks to be sure you are applying fertilizer at desired rate.**

To check the exact number of liters your fertilizer attachment will actually deliver on a 70 cm row spacing:

1. Remove hose from one fertilizer opener and insert it into a collection container secured planter frame.
2. Engage fertilizer attachment and drive forward for 14.3 m.
3. Measure fluid milliliters caught in container. Result is liters of fertilizer delivered per hectare when planting in 70 cm rows (e.g. 2ml = 2 L ; 5ml= 5L; 10ml = 10L).
4. Rinse collection container and repeat test on other rows if necessary.

**DRY INSECTICIDE APPLICATION RATES  
APPROXIMATE kg/ha AT 8 km/h FOR VARIOUS ROW WIDTHS**

Meter Setting	70cm Rows
<b>CLAY GRANULES</b>	
10	6.0
11	6.6
12	7.4
13	8.4
14	9.4
15	10.4
16	11.7
17	13.1
18	13.9
19	16.0
20	17.3
21	18.9
22	20.0
23	21.0
24	22.9
25	25.5
26	28.1
27	29.4
28	31.0
29	33.9
30	36.1
<b>SAND GRANULES</b>	
5	3.5
6	6.0
7	6.5
8	7.7
9	9.5
10	10.9
11	12.4
12	13.7
13	15.4
14	17.6
15	18.9
16	21.4
17	23.7
18	26.6
19	29.6
20	31.4
21	33.7
22	36.1
23	39.0
24	42.0
25	45.0

**NOTE:** Chart represents average values and should be used only as a starting point. Granular chemical flows through meter opening at a nearly uniform rate regardless of roller speed. Your actual rate will vary depending on insecticide, planting speed, and plant population. Planting speed/ground speed has the greatest effect on application rate.

Field check your actual rate with insecticide you are using at speed and population you will be planting. See "Checking Granular Chemical Application Rate" in Machine Operation section for more information.

**DRY HERBICIDE APPLICATION RATES  
APPROXIMATE kg/ha AT 8 km/h FOR VARIOUS ROW WIDTHS**

**CLAY GRANULES**

Meter Setting	70cm Rows
10	5.7
11	6.3
12	7.1
13	7.9
14	8.9
15	10.0
16	11.0
17	12.1
18	13.1
19	14.2
20	15.4
21	16.6
22	17.8
23	19.2
24	20.7
25	22.1
26	23.7
27	25.5
28	27.6
29	29.6
30	32.6

**NOTE:** Chart represents average values and should be used only as a starting point. Granular chemical flows through given meter opening at a nearly uniform rate regardless of roller speed. Your actual rate will vary depending on specific herbicide, planting speed, and plant population. Planting speed/ground speed has the greatest effect on application rate.

Field check your actual rate with herbicide you are using at speed and population you will be planting. See "Checking Granular Chemical Application Rate" in Machine Operation section for more information.

# Wheat Disc Section

**NOTE:** Graphite needs to be used unless wheat has been treated, then use 80/20 talc-graphite. Refer to additives section for additional information.

**NOTE:** Verify actual rate by determining seed usage with bulk fill scales and seed density (sds/gram). Adjust target rate as necessary.

**NOTE:** Rates will vary depending on travel speed and vacuum.

231 cell wheat disc refer to [“PLANTING RATES FOR \(VACUUM\) WHEAT 231 CELL DISC” on page 5-30](#)  
 Brush-Type seed meters refer to [“PLANTING RATES FOR BRUSH-TYPE SEED METERS \(HALF RATE DRIVE\)” on page 5-21](#)

Use a 28 tooth Drive sprocket and a 27 tooth Driven sprocket

Drive	Driven	RPM/GS
27	28	3.671
15	15	3.807
28	27	3.948
27	26	3.953

**FOR HYDRAULIC DRIVE (BRUSH-TYPE AND VACUUM) AND ELECTRIC DRIVE (VACUUM)**

- a. Brush-Type: use the instructions found on page 5-16 to find the seeds per revolution (SDS/REV). The SDS/REV will be relatively constant at all speeds for the Brush-Type Meter.
- b. Vacuum: use the instructions found on page 5-16 to find the seeds per revolution (SDS/REV) or look it up in Rate Chart. The SDS/REV will decrease as the disc speed increases (less SDS/REV as ground speed increases) for the True Rate Vacuum Meter.
- c. Divide the SDS/REV by the number of Cells to get the SDS/CELL. Some display may not support 54 cells as an option for number of cells on a seed disc, in that case, substitute a useable number of cells (60 or 40) and use that Cell number in the calculation. **DO NOT PHYSICALLY CHANGE THE DISC. THE CELL COUNT IS FOR THE MONITOR ONLY.**
- d. Divide your target population by the SDS/CELL to get your Monitor Population.

Seed Meter Type	Target Population	SDS/REV	Cells	SDS/CELL	Monitor Population
Brush	800,000	465	54	8.611	92,903
Brush	1,200,000	465	54	8.611	139,355
Vacuum	808,755	891	54	16.500	49,015
Vacuum	1,195,655	771	54	14.278	83,742
Vacuum	808,755	891	60	14.85	54,461
Vacuum	1,195,655	771	60	12.85	93,047



**PLANTING RATES FOR BRUSH-TYPE SEED METERS (HALF RATE DRIVE)**  
**APPROXIMATE SEEDS/HECTARE FOR 35 CM ROW WIDTH**

Transmission Sprockets		Population Factor	Rye 400 SDS/REV, 35.9 SDS/GRAM		Wheat 465 SDS/REV, 39.6 SDS/GRAM		Speed Range (km/h)
Drive	Driven		Population (sds/hectare)	Population (kg/hectare)	Population (sds/hectare)	Population (kg/hectare)	
15	28	3,199.59	1,279,835	35	1,488,134	38	6 to 10
15	27	3,318.09	1,327,237	37	1,543,253	39	6 to 10
15	26	3,445.71	1,378,285	39	1,602,606	40	6 to 10
15	25	3,583.54	1,433,415	40	1,666,710	43	6 to 10
17	28	3,626.20	1,450,480	40	1,686,552	43	6 to 10
15	24	3,732.85	1,493,141	41	1,736,156	44	6 to 10
17	27	3,760.50	1,504,201	41	1,749,020	44	6 to 10
15	23	3,895.15	1,558,060	44	1,811,644	46	6 to 10
17	26	3,905.14	1,562,054	44	1,816,288	46	6 to 10
19	28	4,052.81	1,621,122	45	1,884,970	47	6 to 10
17	25	4,061.35	1,624,538	45	1,888,940	47	6 to 10
19	27	4,202.91	1,681,166	46	1,954,784	50	6 to 10
17	24	4,230.56	1,692,226	47	1,967,643	50	6 to 10
19	26	4,364.57	1,745,827	49	2,029,968	51	6 to 10
17	23	4,414.50	1,765,800	49	2,053,194	52	6 to 10
19	25	4,539.15	1,815,659	51	2,111,167	54	6 to 10
15	19	4,715.18	1,886,072	52	2,193,041	55	6 to 10
19	24	4,728.28	1,891,314	52	2,199,132	56	6 to 10
23	28	4,906.04	1,962,415	55	2,281,807	57	6 to 10
19	23	4,933.86	1,973,542	55	2,294,746	58	6 to 10
23	27	5,087.74	2,035,096	57	2,366,318	60	6 to 10
24	28	5,119.34	2,047,737	57	2,381,015	60	6 to 10
15	17	5,269.91	2,107,963	58	2,451,046	62	6 to 10
23	26	5,283.42	2,113,369	58	2,457,328	62	6 to 10
24	27	5,308.94	2,123,577	60	2,469,203	62	6 to 10
25	28	5,332.64	2,133,057	60	2,480,225	62	6 to 10
17	19	5,343.87	2,137,548	60	2,485,445	63	6 to 10
23	25	5,494.76	2,197,904	61	2,555,624	65	6 to 10
24	26	5,513.14	2,205,255	61	2,564,172	65	6 to 10
25	27	5,530.15	2,212,060	62	2,572,085	65	6 to 10
26	28	5,545.95	2,218,380	62	2,579,433	65	6 to 10
23	24	5,723.70	2,289,481	63	2,662,105	67	6 to 10
24	25	5,733.66	2,293,464	63	2,666,737	67	6 to 10
25	26	5,742.85	2,297,138	65	2,671,010	67	6 to 10
26	27	5,751.36	2,300,544	65	2,674,969	67	6 to 10
27	28	5,759.26	2,303,705	65	2,678,644	68	6 to 10
15	15	5,972.56	2,389,025	67	2,777,852	71	6 to 10
28	27	6,193.77	2,477,508	69	2,880,734	73	6 to 10
27	26	6,202.28	2,480,911	69	2,884,693	73	6 to 10
26	25	6,211.47	2,484,588	69	2,888,966	73	6 to 10
25	24	6,221.42	2,488,568	69	2,893,595	73	6 to 10
24	23	6,232.24	2,492,896	69	2,898,626	73	6 to 10

Continued on the next page.

**PLANTING RATES FOR BRUSH-TYPE SEED METERS (HALF RATE DRIVE)  
APPROXIMATE SEEDS/HECTARE FOR 35 CM ROW WIDTH**

Transmission Sprockets		Population Factor	Rye 400 SDS/REV, 35.9 SDS/GRAM		Wheat 465 SDS/REV, 39.6 SDS/GRAM		Speed Range (km/h)
Drive	Driven		Population (sds/hectare)	Population (kg/hectare)	Population (sds/hectare)	Population (kg/hectare)	
28	26	6,431.99	2,572,797	72	2,991,531	75	6 to 10
27	25	6,450.37	2,580,148	72	3,000,079	75	6 to 10
26	24	6,470.27	2,588,109	72	3,009,338	75	6 to 10
25	23	6,491.92	2,596,767	72	3,019,404	77	6 to 10
19	17	6,675.22	2,670,088	74	3,104,657	78	6 to 10
28	25	6,689.27	2,675,709	74	3,111,194	78	6 to 10
27	24	6,719.13	2,687,653	74	3,125,082	79	6 to 10
26	23	6,751.60	2,700,638	75	3,140,179	79	6 to 10
17	15	6,768.91	2,707,562	75	3,148,232	79	6 to 10
28	24	6,967.99	2,787,197	78	3,240,828	82	6 to 10
27	23	7,011.27	2,804,507	78	3,260,957	83	6 to 10
23	19	7,229.94	2,891,977	80	3,362,662	85	6 to 10
28	23	7,270.94	2,908,378	82	3,381,732	85	6 to 10
24	19	7,544.29	3,017,716	84	3,508,866	89	6 to 10
19	15	7,565.25	3,026,100	84	3,518,612	89	6 to 10
25	19	7,858.63	3,143,453	88	3,655,065	92	6 to 10
23	17	8,080.53	3,232,210	90	3,758,270	95	6 to 10
26	19	8,172.98	3,269,192	91	3,801,270	96	6 to 10
24	17	8,431.86	3,372,744	94	3,921,674	99	6 to 10
27	19	8,487.33	3,394,932	95	3,947,474	100	6 to 10
25	17	8,783.18	3,513,272	97	4,085,075	103	6 to 10
28	19	8,801.67	3,520,668	99	4,093,676	103	6 to 10
26	17	9,134.51	3,653,805	102	4,248,479	107	6 to 10
23	15	9,157.93	3,663,172	102	4,259,370	107	6 to 10
27	17	9,485.83	3,794,333	106	4,411,881	111	6 to 10
24	15	9,556.10	3,822,439	106	4,444,562	112	6 to 10
28	17	9,837.16	3,934,866	110	4,575,285	116	6 to 10
25	15	9,954.27	3,981,709	111	4,629,753	117	6 to 10
26	15	10,352.44	4,140,977	116	4,814,942	122	6 to 10
27	15	10,750.62	4,300,247	119	5,000,134	127	6 to 10
28	15	11,148.79	4,459,514	124	5,185,323	130	6 to 10

**NOTE:** Seed size and type affect the output rate of the meter. For a method to improve the population accuracy with your desired seed, please see the following pages.

**NOTE:** See ["General Planting Rate Information" on page 5-1](#) and ["Check Seed Population" on page 2-46](#) for additional information.

**NOTE:** When using Half Rate (2 To 1) Drive Reduction Package, rates are approximately 50% of given numbers.

**NOTE:** Always field check seed population to ensure planting rates are correct.

To more accurately predict population when using the 54 Cell Singulated Wheat Disc, two things are needed:

1. Seeds/gram
2. Grams/revolution of seed disc

Seeds per gram can be found by weighing a small sample of desired seed (a cup or less) and counting number of seeds in sample.

$$\frac{\text{Seeds}}{\text{Grams}} = \frac{\text{number of seeds in sample}}{\text{weight of sample in grams}} \quad \frac{396 \text{ Seeds}}{10 \text{ Grams}} = 39.6 \frac{\text{seeds}}{\text{gram}}$$

To find grams/revolution a gram scale, a stopwatch, a small container to catch seed, and a method for spinning the meter at a constant, known rpm (see your local Kinze dealer with a T4000 Seed Meter Test Stand) are needed.

1. Zero gram scale with the small container on it.
2. Load meter with correct disc.
3. Load meter with desired seed.
4. Start spinning meter at a known, constant rpm.
5. Start stopwatch as you place container under meter.
6. Catch seed with container for 10-30 seconds.
7. Stop the stopwatch as you remove container from underneath meter.
8. Weigh container.
9. Enter meter rpm, weight of sample, and duration of sample collection into the equation below:

$$\frac{\text{Grams}}{\text{Rev}} = \frac{\text{Sample Weight} * 60}{\text{Disc RPM} * \text{Sample Duration}}$$

EX: For a sample taken for 30 seconds with meter spinning at 50rpm and weighs 293 grams

$$\frac{293 \text{ Grams} * 60}{50 \text{ RPM} * 30 \text{ Seconds}} = 11.7 \frac{\text{Grams}}{\text{Rev}}$$

10. Find desired output rate. For seeds per hectare, use seeds/rev. For kilograms per hectare, use kg/rev.

- a. Seeds/rev:

$$\frac{\text{Seeds}}{\text{Rev}} = \frac{\text{Seeds}}{\text{Grams}} * \frac{\text{Grams}}{\text{Rev}} \quad \left| \quad 39.6 \frac{\text{Seeds}}{\text{Grams}} * 11.7 \frac{\text{Grams}}{\text{Rev}} = 465 \frac{\text{Seeds}}{\text{Rev}} \right.$$

- b. Kg/rev:

$$\frac{\text{Kilograms}}{\text{Rev}} = \frac{\text{Grams}}{1000 \text{ Grams}} \quad \left| \quad \frac{11.7 \frac{\text{Grams}}{\text{Rev}}}{1000 \text{ Grams}} = 0.0117 \frac{\text{Kilograms}}{\text{Rev}} \right.$$

11. Find the correct population factor by dividing the desired population by the measured output rate.

Seeds/hectare:

$$\frac{\text{Target Population}}{\text{Output Rate}} = \text{Population Factor} \quad \left| \quad \frac{2,687,831 \frac{\text{Seeds}}{\text{Hectare}}}{465 \frac{\text{Seeds}}{\text{Rev.}}} = 5780.28$$

kg/hectare:

$$\frac{\text{Target Population}}{\text{Output Rate}} = \text{Population Factor} \quad \left| \quad \frac{68 \frac{\text{kg}}{\text{hectare}}}{0.0117 \frac{\text{kg}}{\text{rev}}} = 5811.97$$

12. Find the closest Population Factor in the Rate Chart to identify the correct transmission sprockets. For the examples list above, the closest Population Factor is 5759.26 which corresponds to a 27 tooth Drive sprocket and 28 tooth Driven sprocket.

**NOTE: Multiple trials are recommended to increase the accuracy of the predicted rate.**

**PLANTING RATES FOR (VACUUM) WHEAT 54 CELL DISC  
(HALF RATE DRIVE [15 TOOTH])  
APPROXIMATE SEEDS/HECTARE FOR 35 CM ROW WIDTH**

Transmission Sprockets		RPM/GS (Seed Disc RPM To Ground Speed (km/h))	81NH2O, no sigulator		81NH2O, sigulator 3.3		Speed Range (km/h)
Drive	Driven		SDS/REV	Population	SDS/REV	Population	
15	28	1.267	909	2,002,809	554	1,219,334	8 to 11
15	27	1.314	903	2,056,694	551	1,252,385	8 to 11
15	26	1.365	897	2,114,134	547	1,287,682	8 to 11
15	25	1.420	891	2,175,483	543	1,325,459	8 to 11
17	28	1.436	888	2,194,326	542	1,337,079	8 to 11
15	24	1.479	883	2,241,141	539	1,365,982	8 to 11
17	27	1.490	882	2,253,208	539	1,373,439	8 to 11
15	23	1.543	876	2,311,561	535	1,409,551	8 to 11
17	26	1.547	875	2,315,865	535	1,412,217	8 to 11
19	28	1.605	868	2,379,026	531	1,451,401	8 to 11
17	25	1.609	868	2,382,650	530	1,453,652	8 to 11
19	27	1.665	861	2,442,390	527	1,490,808	8 to 11
17	24	1.676	860	2,453,973	526	1,498,022	8 to 11
19	26	1.729	854	2,509,686	522	1,532,773	8 to 11
17	23	1.749	852	2,530,278	521	1,545,639	8 to 11
19	25	1.798	846	2,581,265	518	1,577,544	8 to 11
15	19	1.868	838	2,652,284	513	1,622,106	8 to 11
19	24	1.873	837	2,657,522	513	1,625,398	8 to 11
23	28	1.943	829	2,727,970	508	1,669,760	8 to 11
19	23	1.955	828	2,738,889	508	1,676,652	8 to 11
23	27	2.016	821	2,798,761	504	1,714,493	8 to 11
24	28	2.028	819	2,810,944	503	1,722,211	8 to 11
15	17	2.088	813	2,868,489	499	1,758,716	8 to 11
23	26	2.093	812	2,873,613	499	1,761,973	8 to 11
24	27	2.103	811	2,883,270	498	1,768,112	8 to 11
25	28	2.112	810	2,892,214	497	1,773,801	8 to 11
17	19	2.117	809	2,896,445	497	1,776,493	8 to 11
23	25	2.177	803	2,952,842	493	1,812,439	8 to 11
24	26	2.184	802	2,959,650	493	1,816,788	8 to 11
25	27	2.191	801	2,965,945	493	1,820,810	8 to 11
26	28	2.197	801	2,971,782	492	1,824,538	8 to 11
23	24	2.267	793	3,036,784	488	1,866,162	8 to 11
24	25	2.272	792	3,040,388	487	1,868,475	8 to 11
25	26	2.275	792	3,043,713	487	1,870,611	8 to 11
26	27	2.278	792	3,046,790	487	1,872,585	8 to 11
27	28	2.282	791	3,049,644	487	1,874,417	8 to 11
15	15	2.366	782	3,125,801	482	1,923,438	8 to 11
28	27	2.454	772	3,202,977	476	1,973,374	8 to 11
27	26	2.457	772	3,205,909	476	1,975,275	8 to 11
26	25	2.461	772	3,209,073	476	1,977,328	8 to 11
25	24	2.465	771	3,212,494	476	1,979,550	8 to 11
24	23	2.469	771	3,216,212	475	1,981,963	8 to 11
28	26	2.548	762	3,284,041	471	2,026,118	8 to 11
27	25	2.556	762	3,290,206	470	2,030,142	8 to 11
26	24	2.563	761	3,296,872	470	2,034,494	8 to 11
25	23	2.572	760	3,304,099	469	2,039,217	8 to 11
19	17	2.644	752	3,364,614	465	2,078,867	8 to 11
28	25	2.650	752	3,369,203	465	2,081,879	8 to 11
27	24	2.662	750	3,378,927	464	2,088,273	8 to 11
26	23	2.675	749	3,389,458	463	2,095,200	8 to 11
17	15	2.682	748	3,395,059	463	2,098,888	8 to 11
28	24	2.761	740	3,458,662	458	2,140,885	8 to 11

Continued on next page.

**PLANTING RATES FOR (VACUUM) WHEAT 54 CELL DISC  
(HALF RATE DRIVE [15 TOOTH])  
APPROXIMATE SEEDS/HECTARE FOR 35 CM ROW WIDTH**

Transmission Sprockets		RPM/GS (Seed Disc RPM To Ground Speed (km/h))	8INH2O, no sigulator		8INH2O, sigulator 3.3		Speed Range (km/h)
Drive	Driven		SDS/REV	Population	SDS/REV	Population	
27	23	4.469	738	3,472,292	457	2,149,916	8 to 11
23	19	4.609	729	3,540,088	452	2,195,007	8 to 11
28	23	4.635	728	3,552,602	451	2,203,361	8 to 11
24	19	4.809	717	3,634,408	445	2,258,249	8 to 11
19	15	4.822	716	3,640,562	445	2,262,400	8 to 11
25	19	5.009	704	3,725,023	438	2,319,630	8 to 11
23	17	5.151	695	3,786,759	433	2,361,838	8 to 11
26	19	5.210	692	3,811,937	431	2,379,150	8 to 11
24	17	5.375	682	3,880,734	426	2,426,772	8 to 11
27	19	5.410	680	3,895,152	425	2,436,811	8 to 11
25	17	5.599	668	3,970,088	419	2,489,383	8 to 11
28	19	5.610	668	3,974,663	418	2,492,614	8 to 11
26	17	5.823	655	4,054,817	412	2,549,669	8 to 11
23	15	5.837	654	4,060,299	411	2,553,605	8 to 11
27	17	6.046	642	4,134,920	405	2,607,632	8 to 11
24	15	6.091	640	4,150,387	403	2,618,945	8 to 11
28	17	6.270	630	4,210,402	398	2,663,270	8 to 11
25	15	6.345	625	4,234,536	395	2,681,300	8 to 11
26	15	6.599	611	4,312,743	388	2,740,670	8 to 11
27	15	6.853	598	4,385,013	381	2,797,056	8 to 11
28	15	7.106	584	4,451,343	374	2,850,458	8 to 11

**NOTE:** The SDS/REV values shown in the table above are examples and not actual predicted results, as they are accurate only under one specific set of conditions (8 INH2O vacuum pressure, target speed of 9.66 km/h, and seed density of 25.88 seeds/gram). Once a different ground speed is used, other than 9.66 km/h, the values in the table will no longer apply.

1. Identify planting parameters and record in Table #1.
2. Weigh small sample of seeds and complete Table #2.
3. Use a device to spin the meter at a constant, measured RPM (Seed Meter Test Stand T4000). Set the RPM to settings in the table below (15, 20, 25, 30) and collect a sample of seed coming out of the meter. It is recommended to start with a Vacuum pressure of 8INH<sub>2</sub>O and removing the singulator. Increasing the vacuum pressure will increase the SDS/REV while using the singulator will decrease the SDS/REV. Weigh the sample of seed and record the length of time the sample was collected in Table #3.
4. Complete Table #3 for each RPM setting using information from Tables 1 and 2. Variables with the subscript “[<sub>RPM</sub>]” use the values in the same row in Table #3.
5. Choose the 2 closest populations to your desired target population and add them to Table #4 with their respective seeds per rev.
6. Complete Table #4 and calculate the approximate seeds per rev.
7. Calculate Seed Disc RPM/Ground Speed Ratio in Table #5.
8. Select the closest RPM/GS (Seed Disc RPM to Ground Speed (km/h)) in the rate chart and use that Drive and Driven pair.

Table #1				Table #2	
Target Population [seeds/hectare] ( <b>Pop<sub>TAR</sub></b> )				Number of Seeds ( <b>N</b> )	
Ideal Planting Ground Speed [km/h] ( <b>GS</b> )				Weight of sample [grams] ( <b>W</b> )	
Planter Row Spacing [cm] ( <b>RS</b> )				Seeds/ Gram = <b>N/W (SG)</b>	
Table #3					
			$SR_{RPM} = \frac{W_{RPM}}{t_{RPM}} \times \left(\frac{60}{RPM}\right) \times SG$		$Pop_{RPM} = \frac{SR_{RPM} \times RPM \times 60,000}{GS \times RS}$
Vacuum Pressure	Disc RPM	Weight [grams] ( <b>W<sub>RPM</sub></b> )	Time [sec.] ( <b>t<sub>RPM</sub></b> )	Seeds/ Rev ( <b>SR<sub>RPM</sub></b> )	Population ( <b>Pop<sub>RPM</sub></b> )
	15				
Sing. Setting	20				
	25				
	30				
Table #4					
<b>Pop<sub>1</sub></b>		<b>Pop<sub>2</sub></b>		<b>Pop<sub>TAR</sub></b>	
<b>SR<sub>1</sub></b>		<b>SR<sub>2</sub></b>			
$SR_{TAR} = \left(\frac{SR_2 - SR_1}{Pop_2 - Pop_1}\right) \times (Pop_{TAR} - Pop_1) + SR_1$					
Table #5					
<b>GS</b>		$RPM_{TAR} = \frac{Pop_{TAR} \times GS \times RS}{60,000 \times SR_{TAR}}$			
<b>RS</b>					
<b>Pop<sub>TAR</sub></b>		$\frac{RPM_{Tar}}{GS}$			
<b>SR<sub>TAR</sub></b>					

NOTE: Additional worksheets can be found on [page 5-29](#)

Example.

Table #1				Table #2		
Target Population [seeds/hectare] ( <b>Pop<sub>TAR</sub></b> )		3,200,000		Number of Seeds ( <b>N</b> )		260
Ideal Planting Ground Speed [km/h] ( <b>GS</b> )		10 km/h		Weight of sample [grams] ( <b>W</b> )		10
Planter Row Spacing [cm] ( <b>RS</b> )		35 cm		Seeds/ Gram = <b>N/W (SG)</b>		26
Table #3						
			$SR_{RPM} = \frac{W_{RPM}}{t_{RPM}} \times \left(\frac{60}{RPM}\right) \times SG$		$Pop_{RPM} = \frac{SR_{RPM} \times RPM \times 60,000}{GS \times RS}$	
Vacuum Pressure	Disc RPM	Weight [grams] ( <b>W<sub>RPM</sub></b> )	Time [sec.] ( <b>t<sub>RPM</sub></b> )	Seeds/ Rev ( <b>SR<sub>RPM</sub></b> )	Population ( <b>Pop<sub>RPM</sub></b> )	
8	15	$\frac{765}{90.4} \times \left(\frac{60}{15}\right) \times 26 = 880.1$		$\frac{880.1 \times 15 \times 60,000}{10 \times 35} = 2,263,114.3$		
		765	90.4	880.1	2,263,114.3	
Sing. Setting	20	$\frac{640}{60.5} \times \left(\frac{60}{20}\right) \times 26 = 825.1$		$\frac{825.1 \times 20 \times 60,000}{10 \times 35} = 2,828,914.3$		
		640	60.5	825.1	2,828,914.3	
removed	25	$\frac{1101}{90.1} \times \left(\frac{60}{25}\right) \times 26 = 762.5$		$\frac{762.5 \times 25 \times 60,000}{10 \times 35} = 3,267,857.1$		
		1101	90.1	762.5	3,267,857.1	
removed	30	$\frac{840}{60.6} \times \left(\frac{60}{30}\right) \times 26 = 720.8$		$\frac{720.8 \times 30 \times 60,000}{10 \times 35} = 3,706,971.4$		
		840	60.6	720.8	3,706,971.4	
Table #4						
<b>Pop<sub>1</sub></b>	3,267,857.1	<b>Pop<sub>2</sub></b>	3,706,971.4	<b>Pop<sub>TAR</sub></b>	3,200,000	
<b>SR<sub>1</sub></b>	762.5	<b>SR<sub>2</sub></b>	720.8			
$SR_{TAR} = \left(\frac{SR_2 - SR_1}{Pop_2 - Pop_1}\right) \times (Pop_{TAR} - Pop_1) + SR_1$				768.9		
$\left(\frac{720.8 - 762.5}{3,706,971.4 - 3,267,857.1}\right) \times (3,200,000 - 3,267,857.1) + 762.5 = 768.9$						
Table #5						
<b>GS</b>	10 km/h	$RPM_{TAR} = \frac{Pop_{TAR} \times GS \times RS}{60,000 \times SR_{TAR}}$		24.3		
<b>RS</b>	35 cm					
<b>Pop<sub>TAR</sub></b>	3,200,000	$\frac{3,200,000 \times 10 \times 35}{60,000 \times 768.9} = 24.3$				
<b>SR<sub>TAR</sub></b>	768.9	$\frac{RPM_{Tar}}{GS} = \frac{24.3}{10} = 2.43$		2.43		



Additional Worksheet

Table #1				Table #2	
Target Population [seeds/hectare] ( $Pop_{TAR}$ )				Number of Seeds ( <b>N</b> )	
Ideal Planting Ground Speed [km/h] ( <b>GS</b> )				Weight of sample [grams] ( <b>W</b> )	
Planter Row Spacing [cm] ( <b>RS</b> )				Seeds/ Gram = <b>N/W (SG)</b>	
Table #3					
				$SR_{RPM} = \frac{W_{RPM}}{t_{RPM}} \times \left(\frac{60}{RPM}\right) \times SG$	
				$Pop_{RPM} = \frac{SR_{RPM} \times RPM \times 60,000}{GS \times RS}$	
Vacuum Pressure	Disc RPM	Weight [grams] ( $W_{RPM}$ )	Time [sec.] ( $t_{RPM}$ )	Seeds/ Rev ( $SR_{RPM}$ )	Population ( $Pop_{RPM}$ )
	15				
Sing. Setting	20				
	25				
	30				
Table #4					
$Pop_1$		$Pop_2$		$Pop_{TAR}$	
$SR_1$		$SR_2$			
$SR_{TAR} = \left(\frac{SR_2 - SR_1}{Pop_2 - Pop_1}\right) \times (Pop_{TAR} - Pop_1) + SR_1$					
Table #5					
GS		$RPM_{TAR} = \frac{Pop_{TAR} \times GS \times RS}{60,000 \times SR_{TAR}}$			
RS					
$Pop_{TAR}$					
$SR_{TAR}$					
		$\frac{RPM_{Tar}}{GS}$			

**PLANTING RATES FOR (VACUUM) WHEAT 231 CELL DISC  
(HALF RATE DRIVE [44 TOOTH])  
APPROXIMATE SEEDS/HECTARE FOR 35 CM ROW WIDTH**

Transmission Sprockets		Population	Speed Range (km/h)
Drive	Driven		
15	28	1,358,070	5 to 11
15	27	1,408,357	5 to 11
15	26	1,462,522	5 to 11
15	25	1,521,024	5 to 11
17	28	1,539,131	5 to 11
15	24	1,584,396	5 to 11
17	27	1,596,149	5 to 11
15	23	1,653,282	5 to 11
17	26	1,657,523	5 to 11
19	28	1,720,209	5 to 11
17	25	1,723,823	5 to 11
19	27	1,783,923	5 to 11
17	24	1,795,658	5 to 11
19	26	1,852,525	5 to 11
17	23	1,873,732	5 to 11
19	25	1,926,642	5 to 11
15	19	2,001,350	5 to 11
19	24	2,006,902	5 to 11
23	28	2,082,351	5 to 11
19	23	2,094,162	5 to 11
23	27	2,159,491	5 to 11
24	28	2,172,901	5 to 11
15	17	2,236,805	5 to 11
24	27	2,253,371	5 to 11
17	19	2,268,206	5 to 11
23	25	2,332,241	5 to 11
26	28	2,353,982	5 to 11
23	24	2,429,428	5 to 11
24	25	2,433,651	5 to 11
27	28	2,444,512	5 to 11
23	23	2,535,043	5 to 11
28	27	2,628,940	5 to 11
27	26	2,632,553	5 to 11
24	23	2,647,746	5 to 11
28	26	2,730,044	5 to 11
27	25	2,737,862	5 to 11
25	23	2,755,492	5 to 11
19	17	2,833,280	5 to 11
27	24	2,851,936	5 to 11
26	23	2,865,706	5 to 11
28	24	2,957,551	5 to 11
27	23	2,975,923	5 to 11
23	19	3,068,735	5 to 11
28	23	3,086,137	5 to 11
24	19	3,202,172	5 to 11
25	19	3,335,589	5 to 11
23	17	3,429,773	5 to 11
26	19	3,469,009	5 to 11
24	17	3,578,902	5 to 11
27	19	3,602,446	5 to 11
25	17	3,728,011	5 to 11
28	19	3,735,865	5 to 11
26	17	3,877,137	5 to 11
23	15	3,887,066	5 to 11
27	17	4,026,246	5 to 11

## LUBRICATION

Following pages show locations of all lubrication points. Proper lubrication of moving parts helps ensure efficient operation of your Kinze planter and prolongs the life of friction producing parts.

### LUBRICATION SYMBOLS



Lubricate at frequency indicated with SAE multipurpose grease.



Lubricate at frequency indicated with high quality SAE 10 weight oil or spray lubricant.

### SEALED BEARINGS

Sealed bearings are used on your Kinze planter to provide trouble free operation.

These are located on drive shafts, row units, and transmission bearings. Sealed bearings are lubricated for life and are not serviceable.

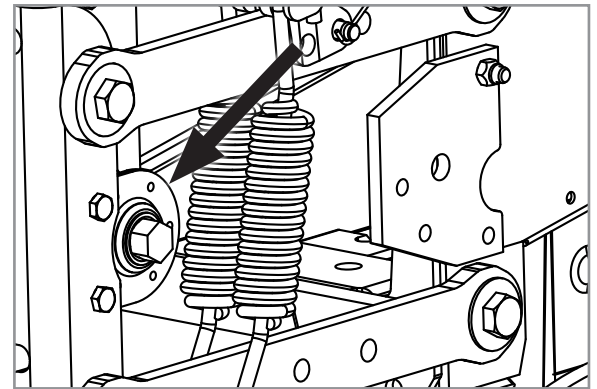

Sealed bearing (Typical)

### WRAP SPRING WRENCH ASSEMBLY

1. Remove ¼"-20 x ½" cap screw securing idler assembly to wrap spring wrench tightener shaft and
2. Remove wrap spring wrench from planter.
3. Tip wrap spring wrench on its side and lubricate with a high-quality spray lubricant. Lubricant must be absorbed into wrap spring area.
4. Reinstall wrap spring wrench on planter.



Wrap spring wrench lubrication

### DRIVE CHAINS

Lubricate all transmission and drive chains daily with a high-quality chain lubricant. Extreme operating conditions such as dirt, temperature, or speed may require more frequent lubrication. If a chain becomes stiff, it should be removed, soaked, and washed in solvent to loosen and remove dirt from joints. Soak chain in oil so lubricant can penetrate between rollers and bushings.

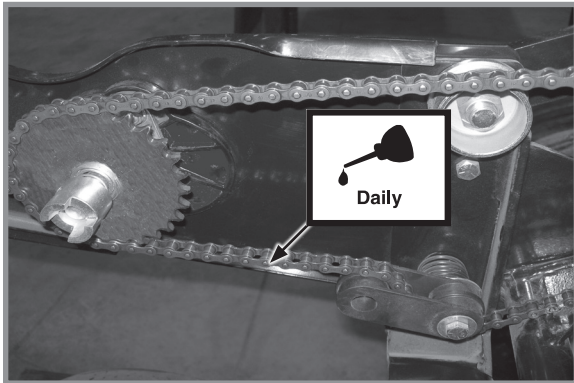

**Pull Row Unit Drive Chains**

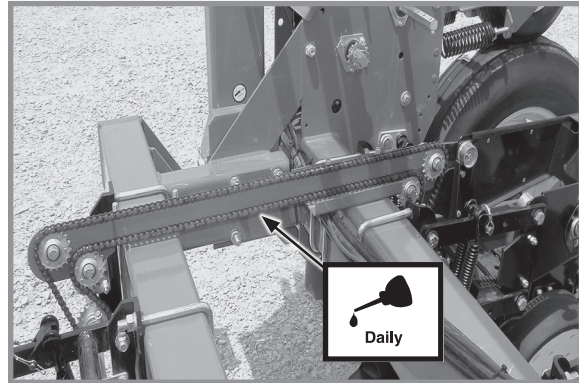

**Split Row Package Drive Chains**

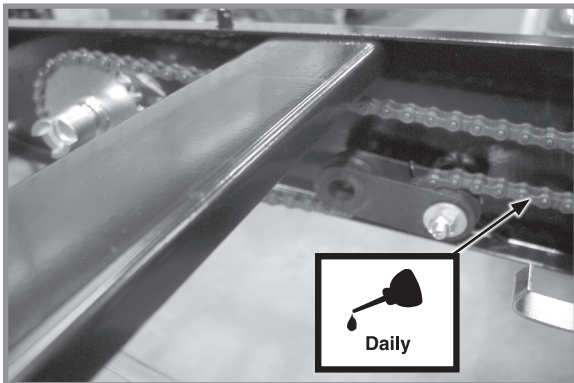

**Row Unit Granular Chemical Drive Chains**

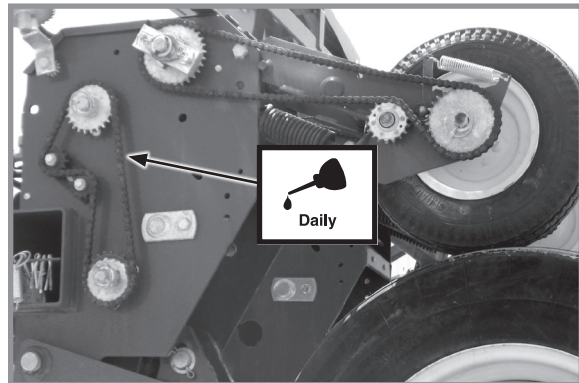

**Contact Wheel Drive Chains  
Seed Rate Transmission Drive Chains**

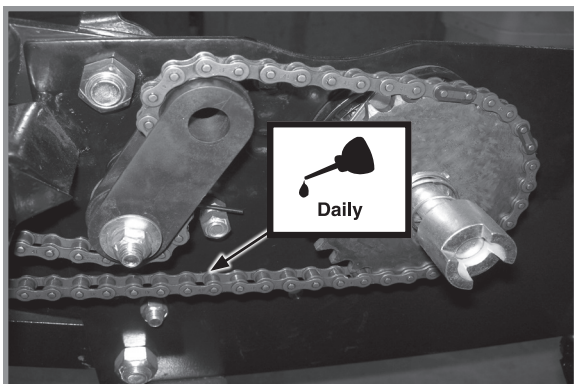

**Push Row Unit Drive Chains**

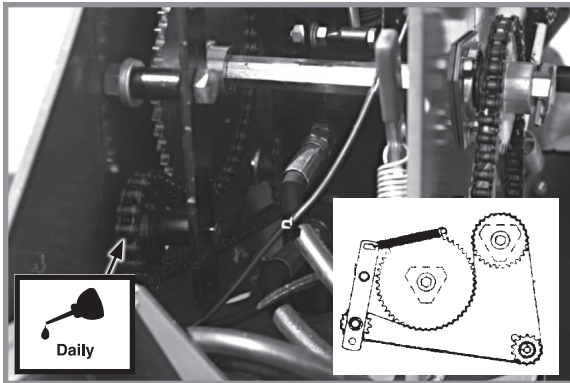

Inner Wheel Module Drive Chains

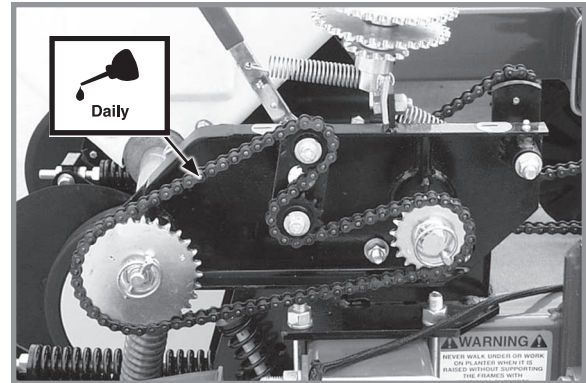

Dry Fertilizer Drive Chains

**BUSHINGS**

Lubricate bushings at frequency indicated.

Check each bolt for proper torque. If bolt is loose, removed it and inspect bushing for cracks and wear. Replace bushing if necessary. Use **only hardened flat washers**. Replace damaged flat washers with proper part. Torque hardware to 176 Nm.

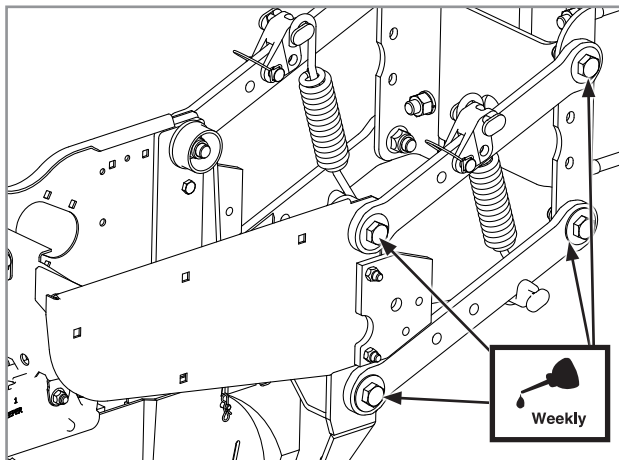

Pull Row Unit and/or Push Row Unit Parallel Linkages (8 per row)

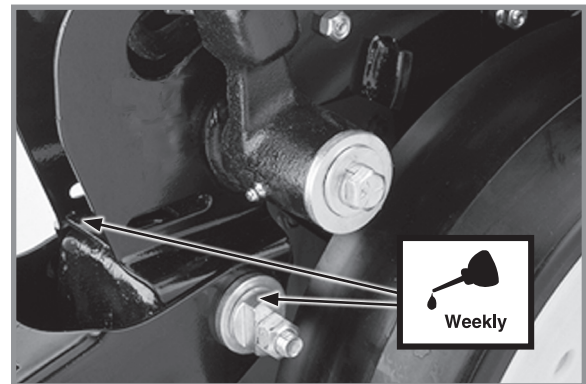

Row Unit "V" Closing Wheel and/or drag closing wheel eccentric bushings (2 per row)

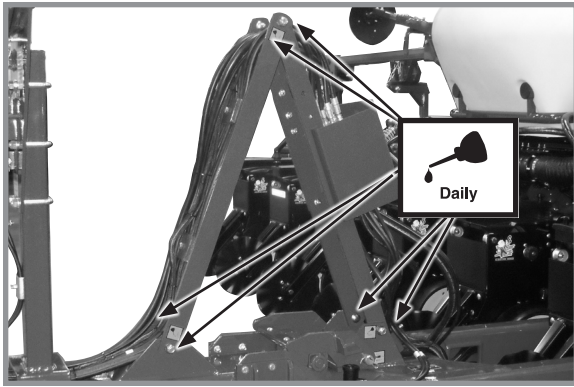

Hose take-up (6 locations)

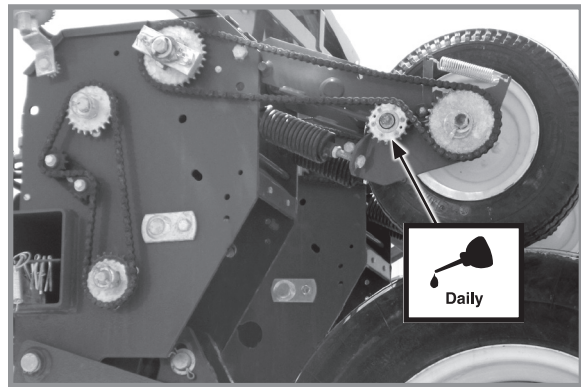

Contact wheel arm (2 per wheel assembly)

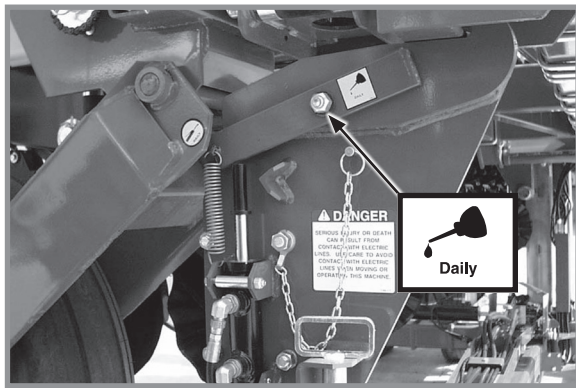

Transport latch (1 location)

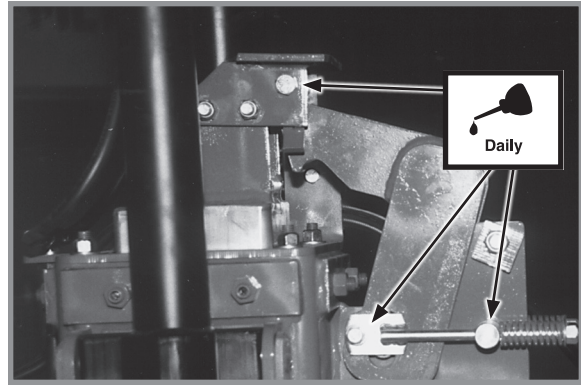

Safety hook at top of center section

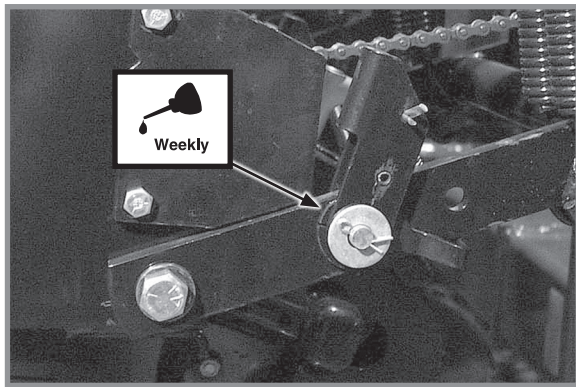

Split Row Push Unit Lockups - 2 per row

## CENTER POST

### NOTICE

Any oil or grease on center post and poly wear pads will attract dirt and accelerate wear. Do not lubricate center post and poly wear pads.

Center post is clad with stainless steel. Keep stainless steel surface clean and free of any lubrication to prolong service life.

See “Wear Pad Adjustment/Replacement” for more information.

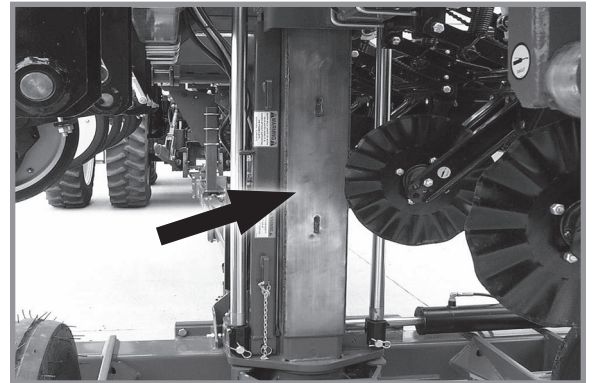

Center post

## U-JOINT SLIDES

Lubricate all U-joint slides daily with a high-quality lubricant.

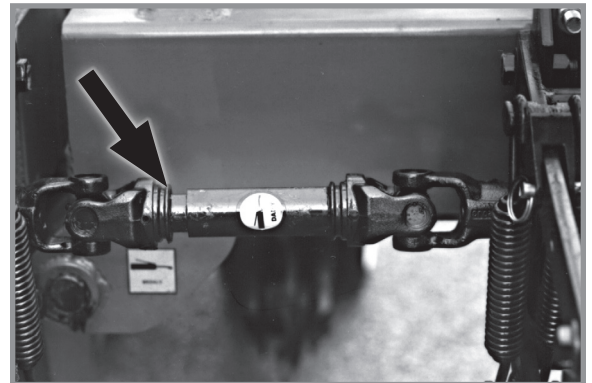

U-joint slide

## WHEEL BEARINGS

All drive, transport, and marker hub wheel bearings should be repacked annually and checked for wear.

1. Raise wheel off ground.
2. Check for bearing endplay by moving wheel side to side.
3. Rotate wheel to check for bearing roughness. If bearings sound rough, remove hub and inspect bearings.

**NOTE:** To repack wheel hubs, follow procedure outlined for wheel bearing replacement except bearings and bearing cups are reused.

## LIQUID FERTILIZER PISTON PUMP CRANKCASE OIL LEVEL

Check crankcase oil daily and maintain at oil level check plug. Fill as needed with EP 90 weight gear oil. Total oil capacity is approximately ¾ pint.

Refer to operator and instruction manual supplied with pump and flow divider for more information.

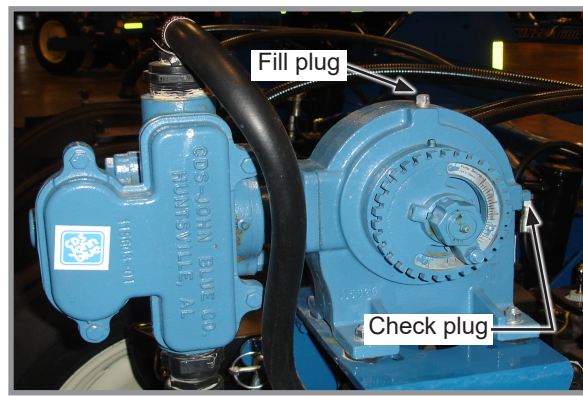

Piston pump oil fill and check plug locations

## GREASE FITTINGS

Parts equipped with grease fittings should be lubricated at frequency indicated with an SAE multipurpose grease. Clean fitting thoroughly before using grease gun. Frequency of lubrication recommended is based on normal operating conditions. Severe or unusual conditions may require more frequent attention.

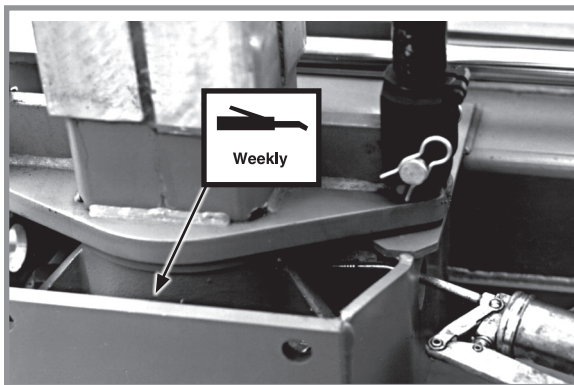

Center Pivot - 1

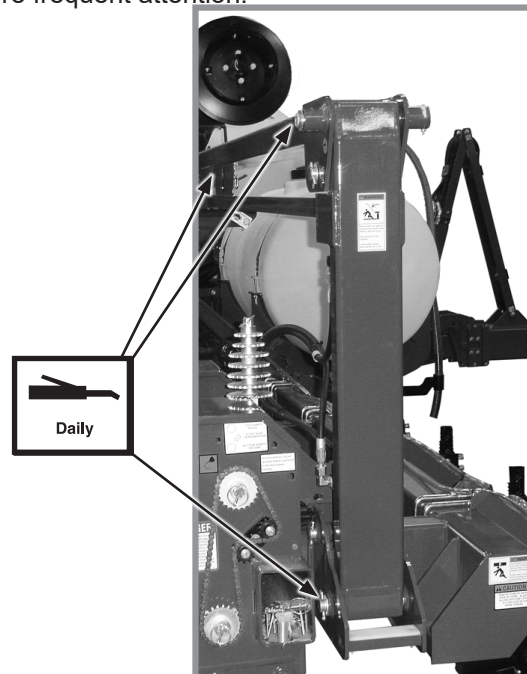

Row marker assemblies - 3 per assembly



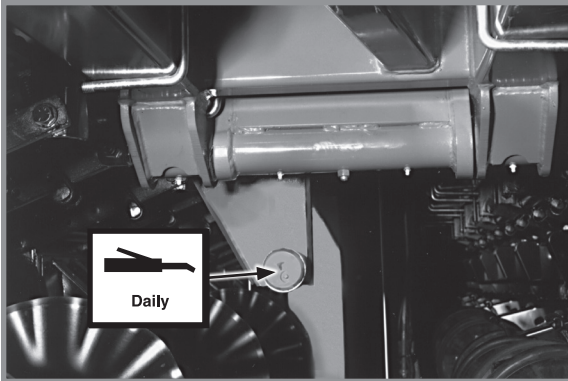

Cam follower - 1 per follower

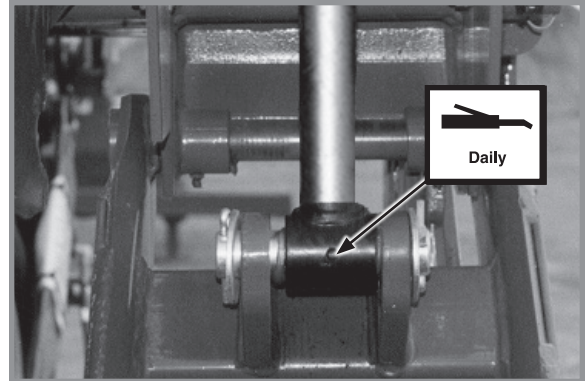

Wing lift cylinders - 1 per cylinder

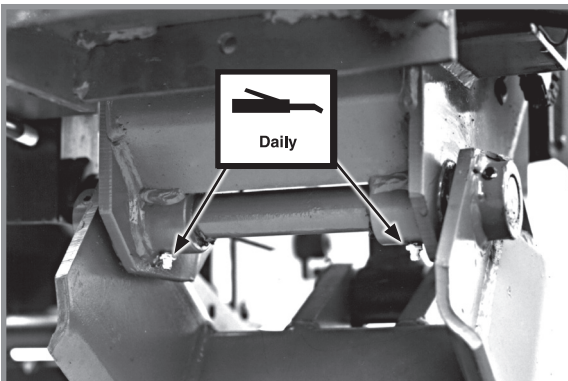

Wing wheel pivot - 2 per wheel module

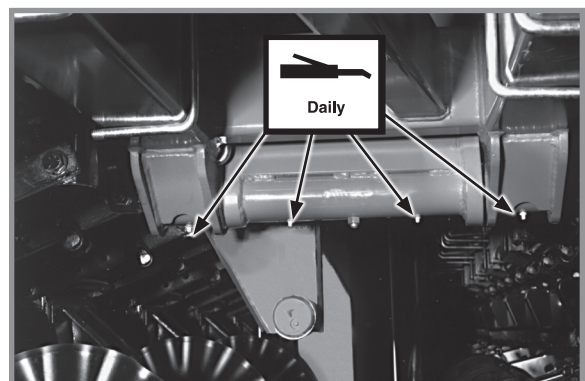

Wing hinges - 4 per wing

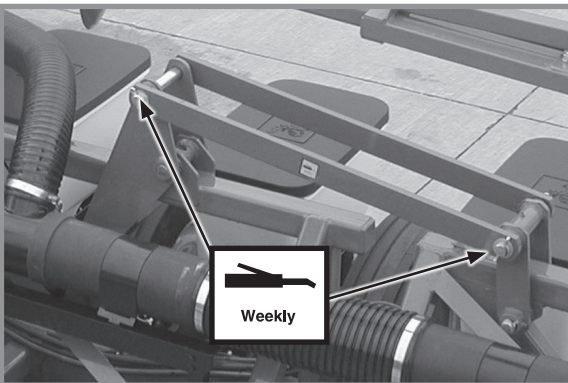

Wing locks - 3 per wing



Transport wheel bearings - 1 per hub

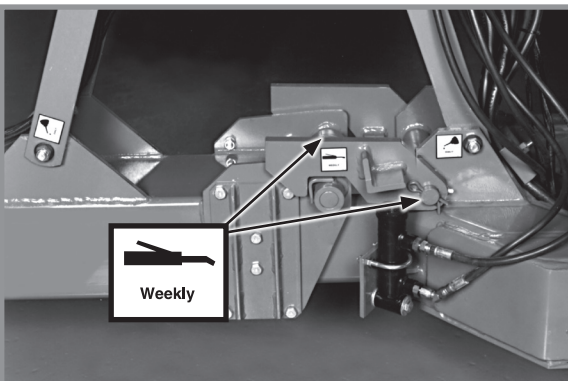

Tongue hook - 2

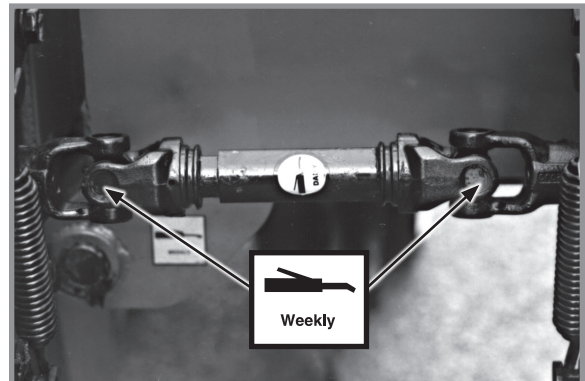

U-joints - 2 per hinge area

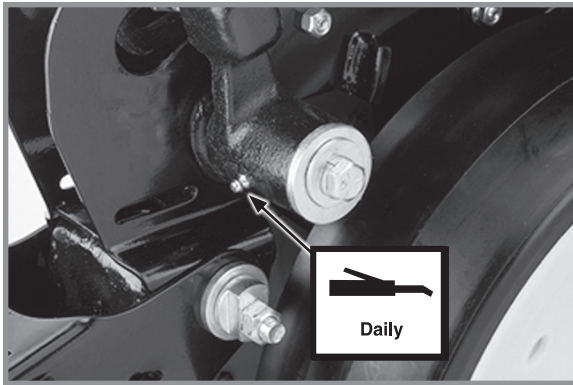

**Gauge wheel arms - 1 per arm**

(Seals in gauge wheel arm are installed with lip facing out to allow grease to purge dirt away from seal. Pump grease into arm until fresh grease appears between washers and arm.)

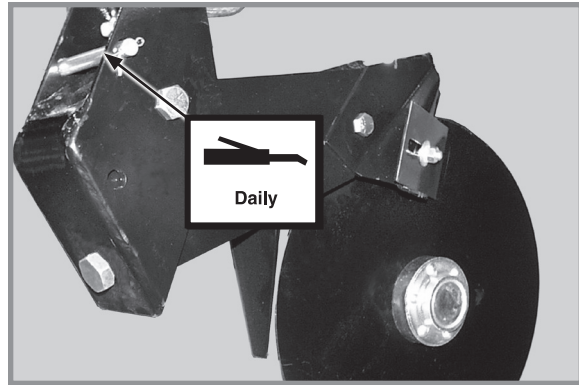

**Double disc fertilizer opener - 1**

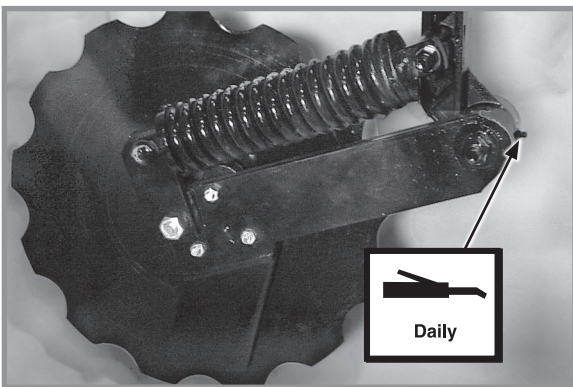

**Notched single disc fertilizer opener - 1**

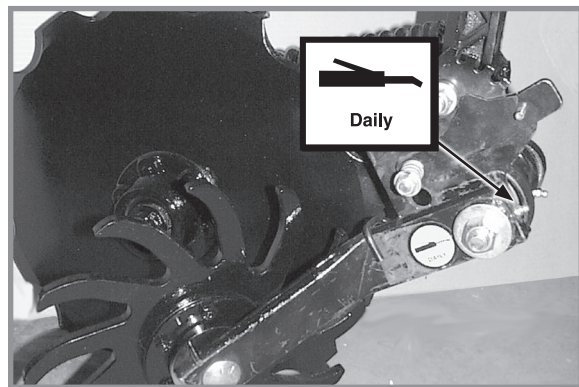

**Residue wheel attachment for use with notched single disc fertilizer opener - 1**

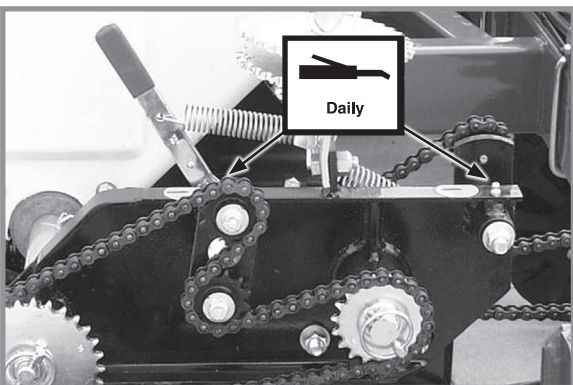

**Dry fertilizer transmission - 2 per transmission**

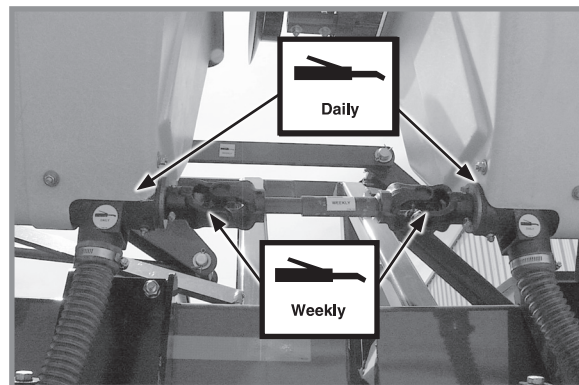

**Dry fertilizer hopper - 2 per hopper  
U-joint - 1 per hinge area**

### PTO PUMP SHAFT AND TRACTOR PTO SHAFT

Lubricate the PTO Pump Shaft and the Tractor PTO Shaft with the LM 47 Long-Life Grease provided with the PTO Pump Mount Assembly kit once a week. The frequency of lubrication is based on normal operating conditions. Severe or unusual conditions may require more frequent attention.

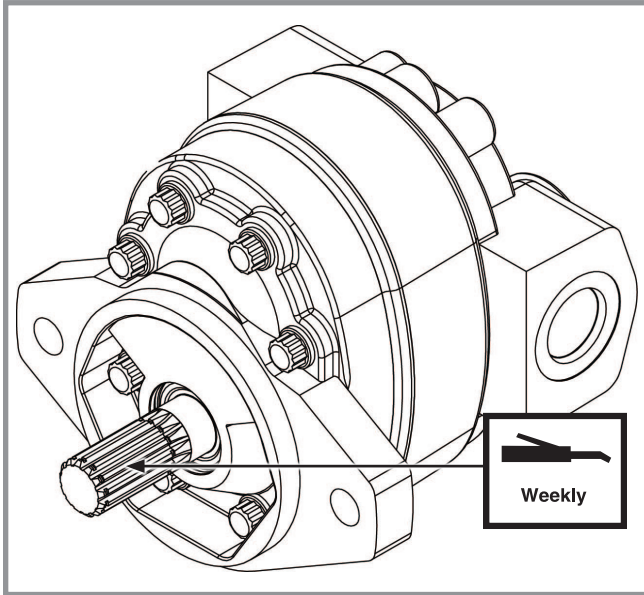

PTO Pump

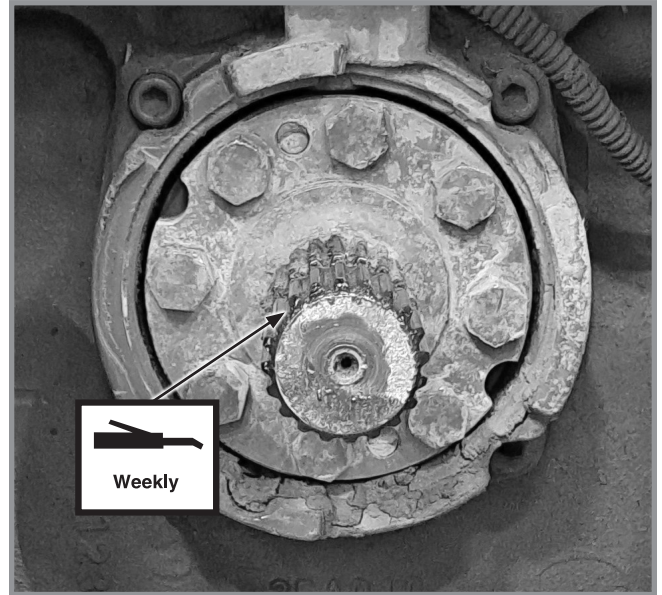

Tractor PTO Shaft

Lubricate the chain installed on the sprockets with a spray lube for chains once a day.

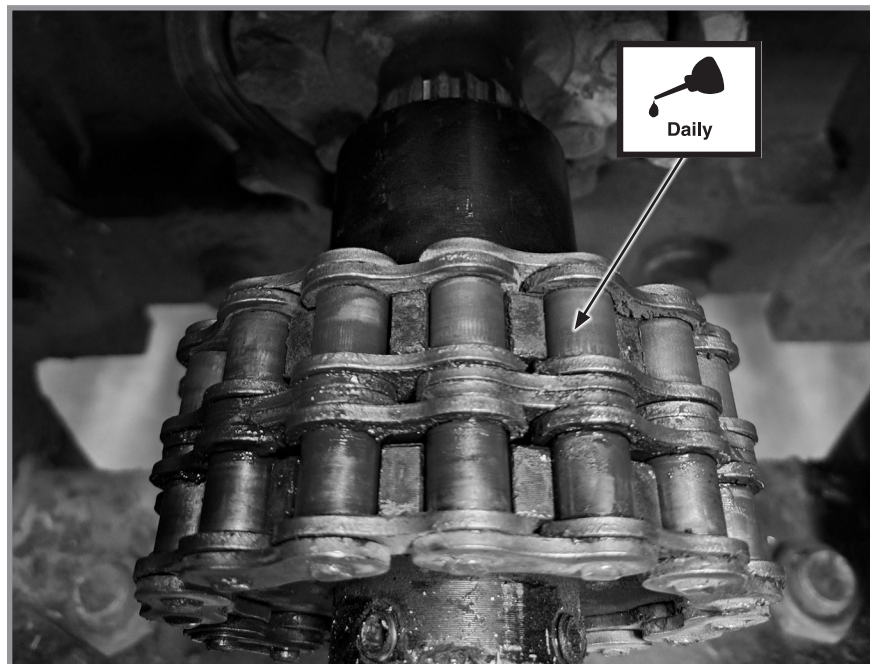

Chain

**MOUNTING BOLTS AND HARDWARE**

Before operating planter for the first time, check all hardware is tight. Check all hardware again after first 50 hours of operation and beginning of each planting season.

All hardware used on the Kinze planter is Grade 5 (high strength) unless otherwise noted. Grade 5 cap screws are marked with three radial lines on the head. Hardware must be replaced with equal size, strength, and thread type.



**WARNING**



Parts separation can result in death, serious injury, and damage to property and equipment. Check all hardware is tight before operating planter the first time. Check all hardware again after first 50 hours of operation and beginning of each planting season.



**NOTICE**

Over-tightening hardware can reduce its shock load capacity and cause equipment failure.

**TORQUE VALUES CHART - PLATED HARDWARE**

Diameter	Grade 2 (No marks) 		Grade 5 (3 marks) 		Grade 8 (6 marks) 	
	Coarse	Fine	Coarse	Fine	Coarse	Fine
1/4"	5.6 Nm	6.3 Nm	8.6 Nm	9.8 Nm	12 Nm	14 Nm
5/16"	11 Nm	12 Nm	18 Nm	19 Nm	24 Nm	27 Nm
3/8"	20 Nm	23 Nm	31 Nm	35 Nm	45 Nm	50 Nm
7/16"	34 Nm	37 Nm	50 Nm	56 Nm	71 Nm	79 Nm
1/2"	48 Nm	54 Nm	77 Nm	87 Nm	108 Nm	122 Nm
9/16"	68 Nm	81 Nm	108 Nm	122 Nm	156 Nm	176 Nm
5/8"	95 Nm	108 Nm	149 Nm	169 Nm	217 Nm	244 Nm
3/4"	176 Nm	197 Nm	271 Nm	298 Nm	380 Nm	427 Nm
7/8"	169 Nm	190 Nm	434 Nm	475 Nm	610 Nm	678 Nm
1"	258 Nm	278 Nm	651 Nm	719 Nm	915 Nm	1017 Nm
1 1/8"	359 Nm	407 Nm	814 Nm	908 Nm	1302 Nm	1458 Nm
1 1/4"	508 Nm	563 Nm	1139 Nm	1261 Nm	1844 Nm	2034 Nm
1 3/8"	664 Nm	759 Nm	1491 Nm	1695 Nm	2413 Nm	2752 Nm
1 1/2"	881 Nm	990 Nm	1966 Nm	2237 Nm	3128 Nm	3620 Nm

**NOTE:** Torque unplated hardware and bolts with lock nuts approximately 1/3 higher than above values. Torque bolts lubricated prior to installation to 70% of value shown in chart.

**TORQUE VALUES - PNEUMATIC DOWN PRESSURE**

Diameter	Torque Value
1/8" NPT	120 in-lb Maximum
1/2"-13	180 in-lb Maximum
3/4"-16	180 in-lb Maximum

**NOTE:** Use these torque values with pneumatic down pressure components.

**SPECIAL TORQUE VALUES**

Row unit parallel linkage bushing hardware	130 ft-lb (176 Nm)
5/8" No till coulter spindle hardware	120 ft-lb (162 Nm)

**CYLINDER ROD PISTON RETAINING NUT  
TORQUE CHART**

	<b>Non-Nylock Nut</b>	<b>Nylock Nut</b>
1/2"-20	55-70 ft-lb (75-95 N-m)	45-55 ft-lb (61-75 N-m)
3/4"-16	115-125 ft-lb (156-169 N-m)	100-115 ft-lb (136-156 N-m)
7/8"-14	150-180 ft-lb (203-244 N-m)	130-150 ft-lb (176-203 N-m)
1"-14	275-330 ft-lb (373-447 N-m)	250-275 ft-lb (339-373 ft-lb)
1 1/8"-12	300-375 ft-lb (407-508 N-m)	275-300 ft-lb (373-407 N-m)
1 1/4"-12	300-375 ft-lb (407-508 N-m)	275-300 ft-lb (373-407 N-m)

**TORQUE VALUES - TRUE DEPTH HYDRAULIC  
DOWN FORCE**

Cylinder Head to Body:	95 Nm
Cylinder Piston to Rod:	68 Nm
Row Unit Valve Cartridge to Line Body:	41 Nm
Row Unit Valve Solenoid to Valve:	7 Nm

**NOTE:**

- 1. A 6-Pt Socket must be used to torque the cylinder head to the body.**
- 2. Apply blue threadlocker to cylinder head threads when reassembling.**
- 3. Replace piston to rod locknut with equivalent 7/16-20 locknut before reassembling.**

**TORQUE VALUES- ALUMINUM**

Diameter	Torque Value
1/8"	15-18 ft-lb (~20-24 Nm)
3/8"	29-32 ft-lb (~39-43 Nm)
1/2"	29-33 ft-lb (~39-45 Nm)
3/4"	29-33 ft-lb (~39-45 Nm)

**NOTE: Use these torque values with pneumatic down pressure components.**

**TORQUE VALUES - WHEEL LUG NUTS**

Wheel	Torque Value	Interval
Transport Wheel	200 ft-lb (270 Nm)	<ul style="list-style-type: none"> <li>Once before first planting;</li> <li>Again after first 50 km or 10 operational hours;</li> <li>Periodically thereafter (at least once before every planting season).</li> </ul>
Wing Ground Drive Wheel	125 ft-lb (170 Nm)	<ul style="list-style-type: none"> <li>Once before first planting;</li> <li>Again after first 50 km or 10 operational hours;</li> <li>Periodically thereafter (at least once before every planting season).</li> </ul>

**TIRE SERVICING**

WARNING

**Explosive separation of rim and tire parts can cause death or serious injury. Overinflation, rim and tire servicing, improper use of rims and tires, or worn or improperly maintained tires could result in a tire explosion.**



To prevent tire explosions:

- Maintain proper tire pressure. Inflating a tire above or below the recommended pressure can cause tire damage.
- Mount tires only by properly trained personnel using proper equipment.
- Replace tires with cuts or bubbles. Replace damaged rims. Replace missing lug bolts and nuts.
- Do not weld or heat wheel assembly. Heating increases tire pressure.

**INFLATION SPECIFICATIONS**

WARNING

**Over-inflation of tires can result in explosive separation of rim and tire and cause death or serious injury. Different size rims are designed for different tire pressures. Inflate to correct pressure for specific rim size.**



Do not exceed the following maximum pressures:

- Rims stamped with “224”: 75 PSI (517 kPa) maximum pressure.
- Rims stamped with “276”: 100 PSI (689 kPa) maximum pressure.

Transport (center section) 9" x 22.5" 14PR . . .110 PSI (758 kPa)

Ground drive (wings) 7.50" x 20" . . . . .40 PSI (276 kPa)

Contact drive - 4.80" x 8" . . . . .50 PSI (345 kPa)

Liquid fertilizer piston pump 7.60" x 15" . . . . .40 PSI (276 kPa)

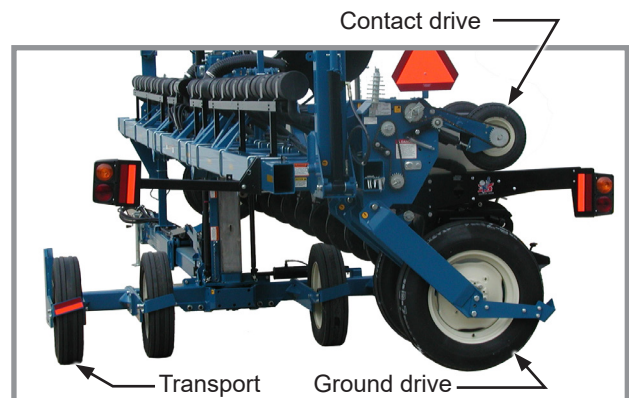

## VACUUM SEED METER MAINTENANCE

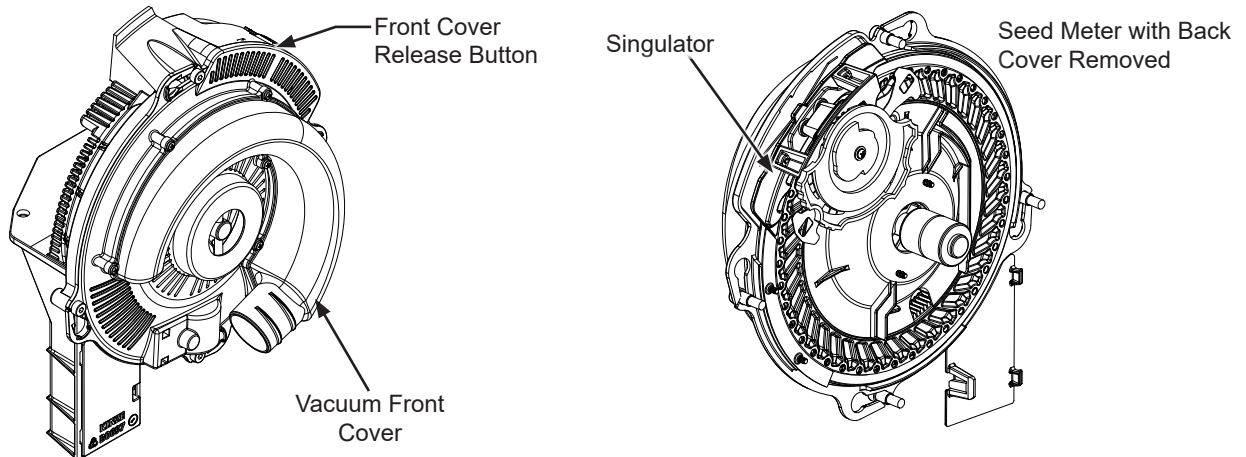

Before each planting season inspect seed discs and singulator and clean or replace as needed.

Use clean, high-quality seed for maximum meter accuracy. Damaged or cracked seed, hulls, and foreign material may become lodged in seed disc orifices and greatly reduce meter accuracy.

Inspect and clean seed discs daily checking for any buildup of foreign material and blocked orifices. If seed disc orifices are plugged frequently with seed remnants, remnants ejector wheel may need to be replaced. Clean seed disc by washing it with soap and water. Dry thoroughly.

Inspect singulator blades and guide for wear after every 80 hectares per row of operation. If adjustment of singulator blade does not affect meter performance or if blades appear worn, singulator blade may need to be replaced.

Replace seed disc or vacuum seal if abnormally high vacuum is required or if consistent operation cannot be achieved.

See ["Preparation for Storage" on page 6-35](#) for additional Vacuum Seed Metering System maintenance.

**NOTE: Remove seed discs from meters for annual storage and store them vertically on a dowel or pipe.**

## SEED METER CLEANOUT

**NOTE: Use of damaged seed or seed containing foreign material will cause plugging of seed cell orifices and require more frequent seed meter cleanout to prevent underplanting.**

Thorough seed meter cleanout is important to maintain genetic purity.

1. Disengage seed drive and remove seed hopper and meter.
2. Dump seed from right rear corner of hopper into a container.
3. Lay hopper on its right side. Push release button and rotate seed meter vacuum cover clockwise to align keyhole slots with bolt heads. Lift off cover.
4. Rotate seed disc hub clockwise to unlock and remove seed disc.
5. Empty meter.
6. Thoroughly inspect meter to ensure all seed is removed.
7. Replace seed disc. Install vacuum cover.

**CHAIN TENSION ADJUSTMENT**

Drive chains have spring loaded idlers and are self-adjusting. Remove link to shorten chain if wear stretches chain and reduces spring tension. Check idler pivot points to make sure they rotate freely. See “Wrap Spring Wrench Assembly” in this section for additional information.

Additional chain links are stored inside planter frame.

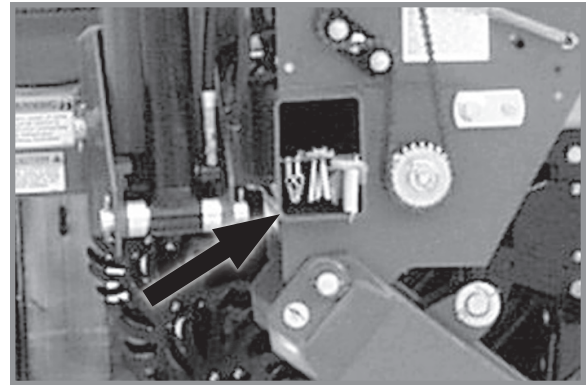

**Additional chain links**

**GAUGE WHEEL ADJUSTMENT**

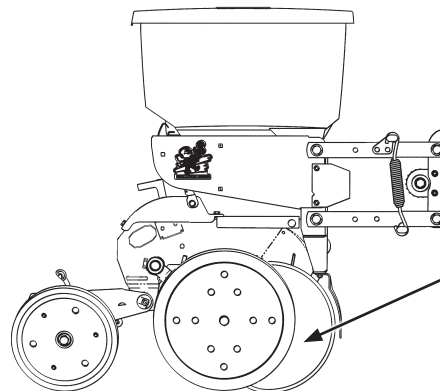
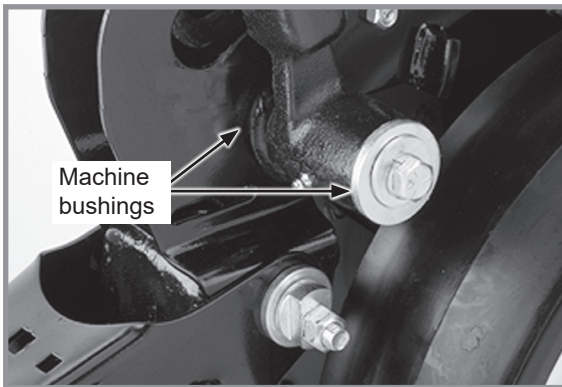

**Gauge wheel adjustment**

Gauge wheels should lightly contact opener blades to prevent accumulation of dirt or trash. Gauge wheels and opener blades should turn with only slight resistance.

Add or remove machine bushings between shank and gauge wheel arm to adjust clearance between gauge wheels and opener blades. Store remaining machine bushings between gauge wheel arm and flat washer on outer side of gauge wheel arm.

**NOTE:** It may be desirable to space gauge wheel further from blade when operating in sticky soils.



## GAUGE WHEEL ARM BUSHING/SEAL REPLACEMENT

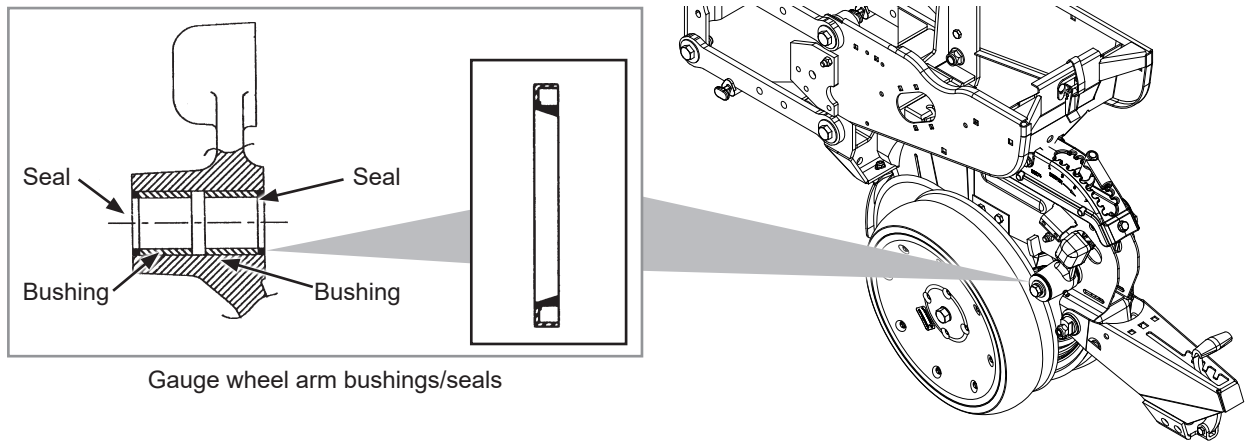

**NOTE: Gauge Wheel Arm Bushing and Seal Driver Kit (G1K296) is available through your Kinze Dealer.**

1. Remove gauge wheel from arm.
2. Remove gauge wheel arm from shank assembly.
3. Remove seal and bushing and discard. Clean and dry inner bore.
4. Drive/press replacement bushing inside bore of arm to a depth of .125" below flush.
5. Coat wiping edge of seal with grease.
6. Drive/press seal into place with lip to outside.

**NOTE: Use extra care to protect the sealing lip during installation. Apply uniform pressure to assemble the seal into the bore of the arm. Never apply a direct hammer blow to the seal surface.**

7. Inspect gauge wheel pivot spindle.
8. Reinstall gauge wheel arm assembly and gauge wheel.

**NOTE: Use special machine bushing between gauge wheel arm and gauge wheel.**

9. Shim for proper gauge wheel tire/disc blade clearance.
10. Lubricate with an SAE multipurpose grease.

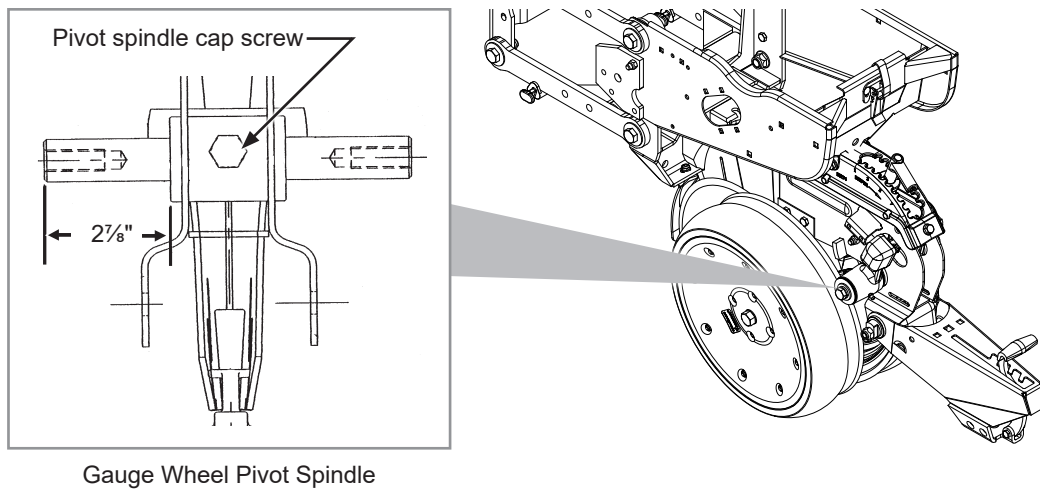
**GAUGE WHEEL ARM PIVOT SPINDLE REPLACEMENT**

1. Remove gauge wheel and arm assemblies from shank assembly.
2. Remove  $\frac{1}{2}$ " x  $\frac{3}{4}$ " cap screw that locks pivot spindle in place and remove spindle.
3. Install replacement spindle and position as shown. Exact centering is critical.
4. Install  $\frac{1}{2}$ " x  $\frac{3}{4}$ " cap screw and torque to lock pivot spindle in place.
5. Install gauge wheel and arm assemblies. Shim for proper gauge wheel tire/disc blade clearance.

## 15" SEED OPENER DISC BLADE/BEARING ASSEMBLY

### NOTICE

Excessive blade contact may result in premature disc opener bearing/hub failures and excessive wear on seed tube guard/inner scraper. When properly adjusted, if one blade is held in fixed position, opposite blade should rotate with less than 5 pounds force (~22 N) at outer edge of blade.

Maintain approximately  $1" \pm \frac{1}{2}"$  (~2.5 ± 1 cm) of blade-to-blade contact to properly open and form seed trench. As blade diameter decreases due to wear, it is necessary to relocate machine bushings from inside to outside to maintain  $1" \pm \frac{1}{2}"$  (~2,5 ± 1 cm) of contact.

**NOTE: Proper blade clearance is critical. Blades should have  $1" \pm \frac{1}{2}"$  (~2,5 ± 1 cm) contact in this area. When blades are turned by hand in opposite directions against each other, there should be only light resistance to turning. Re-adjust blade scraper if necessary to center it between the blades.**

**NOTE: Replace blades if proper blade-to-blade contact cannot be maintained after relocating machine bushings or if blade diameter wears below  $14\frac{1}{2}"$  (~37 cm).**

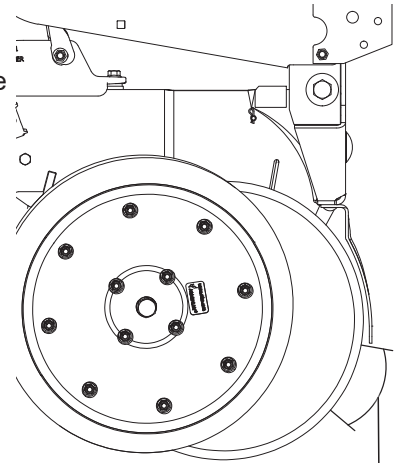

Approximately  $1" \pm \frac{1}{2}"$   
(3 ± .5 cm) of  
blade-to-blade contact.

## REPLACE DISC BLADE/BEARING ASSEMBLY

**NOTE: Only bearing may need to be replaced if there is excessive endplay or if bearing sounds or feels rough when disc blade is rotated.**

1. Remove gauge wheel, scraper, and bearing dust cap.
2. Remove cap screw, washer and disc blade/bearing assembly. Machine bushings between shank and disc blade are used to maintain approximate 25 mm  $\pm$  13 mm of blade-to-blade contact.

**NOTICE**

**Left hand side of opener uses a left hand threaded cap screw. DO NOT OVER TIGHTEN. Damage to shank threads require replacement of row unit shank assembly.**

3. Install machine bushing(s), new disc blade bearing assembly, washer and cap screw. Torque  $\frac{5}{8}$ "-11 Grade 5 cap screw to 150 Nm.

**NOTE: Replace disc blades only with disc blades of equal thickness.**

4. Install bearing dust cap, scraper, and gauge wheel.

## REPLACE BEARING ONLY

1. Remove gauge wheel, scraper, bearing cap, cap screw, washer and disc blade/bearing assembly.
2. Remove  $\frac{1}{4}$ " rivets from bearing housing to expose bearing.
3. Installing new bearing. install three evenly spaced  $\frac{1}{4}$ " cap screws into three of six holes in bearing housing to hold bearing and bearing housing in place. Install rivets in other three holes. Remove  $\frac{1}{4}$ " cap screws and install rivets in those three holes.
4. Reinstall disc blade/bearing assembly, washer and cap screw. Torque  $\frac{5}{8}$ "-11 cap screw to 150 Nm.
5. Install bearing dust cap, scraper, and gauge wheel.

## SEED TUBE GUARD/INNER SCRAPER

Seed tube guard protects seed tube and acts as inner scraper for seed opener disc blades.

Remove seed tube and check for wear. Excessive wear on seed tube indicates a worn seed tube guard. Replace seed tube guard if it measures 16 mm or less at lower end. A new seed tube guard measures approximately 22 mm.

**NOTE: No till planting or planting in hard ground conditions, especially when planter is not equipped with no till coulters, and/or excessive blade-to-blade contact increases seed tube guard wear and requires more frequent inspection and/or replacement.**

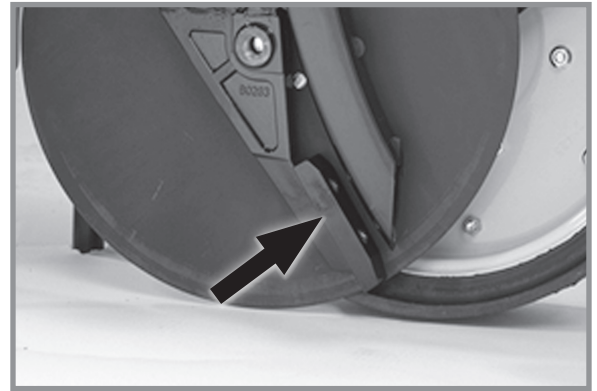

Seed tube guard/inner scraper  
(Gauge wheel/seed opener disc blade removed)

### NOTICE

Over tightening hex socket head cap screws may damage shank threads and require replacement of shank. An excessively worn seed tube guard may allow blades to wear into row unit shank, also requiring replacement of shank.

Remove seed tube and two hex socket head cap screws that attach seed tube guard. Hold replacement seed tube guard centered between seed opener disc blades. Install hex socket head cap screws. **DO NOT TIGHTEN.** Using a clamp or vise-grip, squeeze opener blades together in front of seed tube guard. Tighten seed tube guard retaining screws. Remove clamps. Distance between seed tube guard and opener blades should be equal on both sides. Reinstall seed tube.

## ROW UNIT MOUNTED NO TILL COULTER

Check nuts and hardware periodically for proper torque. Be sure coulters are positioned square with row unit and aligned in front of row unit disc opener.

**NOTE: Torque  $\frac{5}{8}$ " spindle hardware to 162 Nm.**

Coulter blade can be adjusted to one of four settings. Initially blade is set in highest position. As blade wears it can be adjusted to one of three lower settings. See "Row Unit Mounted No Till Coulter" in Row Unit Operation section of this manual.

Replace 16" (40.6 cm) diameter coulters when worn to 37 cm.



Row unit mounted no till coulter

## COULTER MOUNTED RESIDUE WHEELS

Wheel hubs are equipped with sealed bearings. If bearings sound or feel rough when wheel is rotated, replace them.



Coulter mounted residue wheels

## ROW UNIT MOUNTED RESIDUE WHEEL

Wheel hub is equipped with sealed bearings. If a bearing sounds or feels rough when wheel is rotated, replace them.

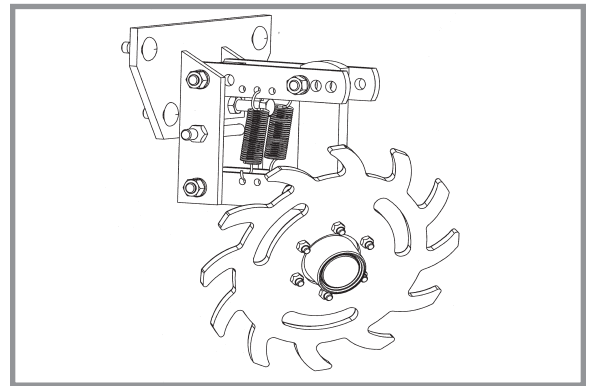

Row unit mounted residue wheels

## GRANULAR CHEMICAL ATTACHMENT

Before storing planter, disengage granular chemical drive by rotating throw out knob  $\frac{1}{4}$  turn counterclockwise. Remove drive chain and empty and clean all granular chemical hoppers. Clean drive chains and coat them with a rust preventive spray or submerge chains in oil. Inspect and replace worn or broken parts.

Install hoppers and chains. Check chain alignment.

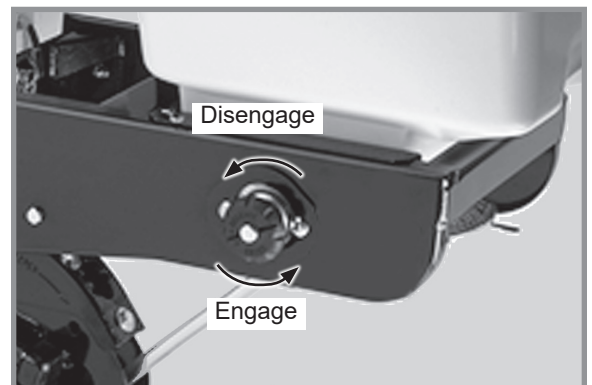

Granular chemical throw out knob

### SPIKED CLOSING WHEEL

Inner parts of spiked closing wheel will begin to wear at approximately 70% of life. Flip/reverse wheel to utilize remaining life of wheel.

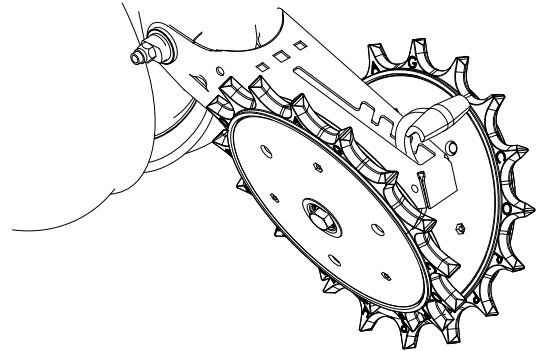

Row Unit Spiked Closing Wheel

### POINT ROW CLUTCH MAINTENANCE

Point row clutch is permanently lubricated and sealed and requires no periodic maintenance.

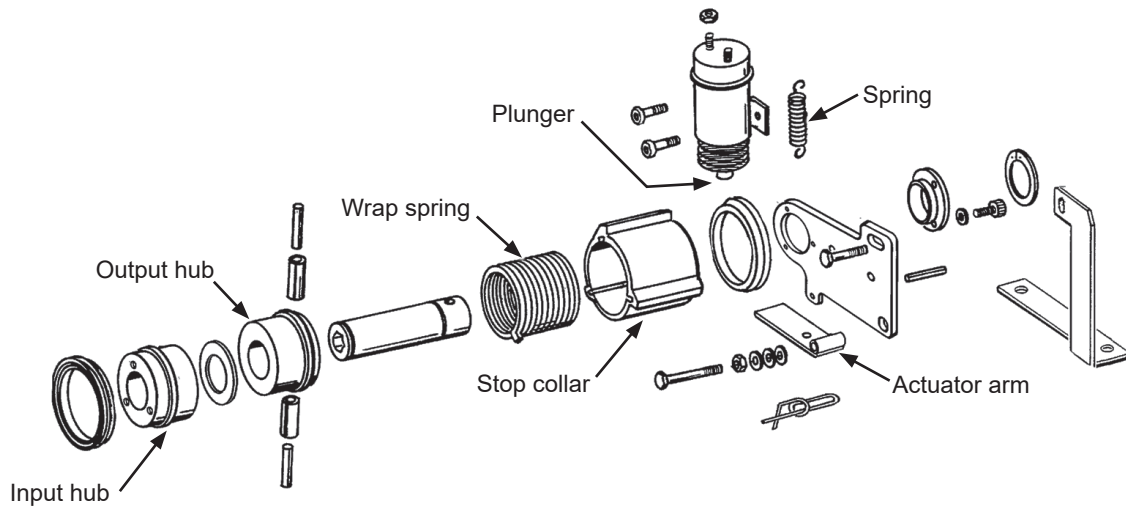

Single point row clutch main parts



## TESTING AND FUSE REPLACEMENT

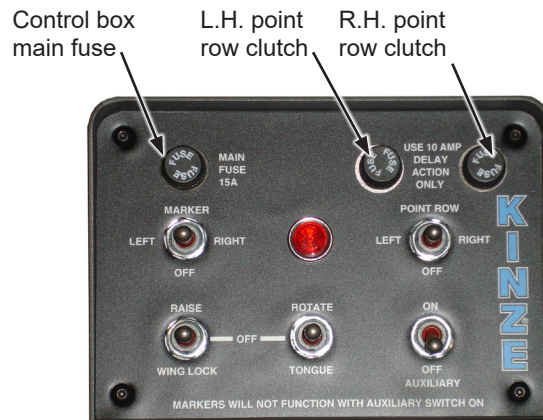

Single speed point row clutch control box  
(Front View)

**NOTE: Replace all point row fuses with MDL 10 amp slow blow fuses.**

If the clutch or clutches fail to operate, first determine if problem is electrical or mechanical.

Place operation switch in RIGHT or LEFT position. Solenoid plunger will retract causing a clicking sound if it is operating properly. Touch plunger with a metal object to check if it is electrically magnetized. Check clutch and wiring harness for power with a test light or volt meter.

**NOTE: R.H. clutch operates clockwise and L.H. clutch operates counterclockwise. Clutch parts such as the wrap spring are side specific. Use correct repair part if a clutch must be repaired.**

Also see "Point Row Clutch Troubleshooting" in Troubleshooting section.

## ACTUATOR ARM ADJUSTMENT

Gap between actuator arm and stop on stop collar should be 3.2 mm ( $\pm .8$  mm) when solenoid is NOT engaged.

Loosen nut on mounting pin and move pin in slot until there is a 3.2 mm ( $\pm .8$  mm) gap between arm and stop on stop collar. Retighten nut.

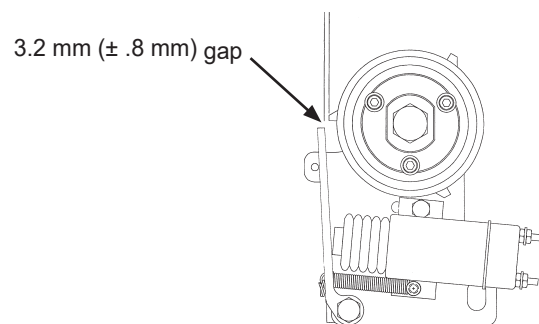

## CHECK VALVE (LIFT SYSTEM)

Check valves, located in valve block on right side of center post, trap oil flow in planter's lift system to keep toolbar level during field operation. Consult your Kinze Dealer for service.

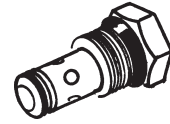

## CHECK VALVE (VACUUM FAN)

Check valve located in valve block below vacuum fan motor assembly operates as a return line check to prevent vacuum fan motor reverse operation. Remove and inspect valve. If it does not operate properly, check for foreign material and if O-ring is leaking internally. Replace if defective.

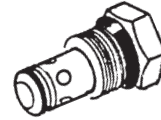

## FLOW CONTROL VALVE

Flow control valves should be adjusted for row marker raise and lower speed as part of assembly procedure or upon initial operation. If valve fails to function properly or requires frequent adjustment, it should be removed for inspection. Check for foreign material and contamination on valve and seating areas of valve body. Replace defective components.

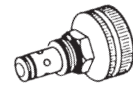

## PRESSURE RELIEF VALVE

If pressure relief valve does not release tongue lock or function properly, remove valve from valve block and check for foreign material or if O-ring is leaking internally. Replace if defective.

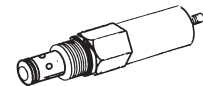

## PRESSURE REDUCING RELIEF VALVE

If wings do not properly stay to ground, plumb into butt end of cylinder to test PSI. Proper setting is 750 PSI (5171 kPa).

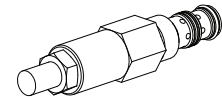

### NOTICE

Connect hydraulic motor case drain to a case drain return line with zero pressure on tractor or hydraulic motor will be damaged. DO NOT connect hydraulic motor case drain to SCV outlet. Contact tractor manufacturer for specific details on "zero pressure return".

## RELIEF VALVE CARTRIDGE

Pressure relief valve located in valve block below vacuum fan motor assembly helps prevent damage to vacuum fan motor by limiting pressure in the motor case drain line. It is set to open at 35 PSI (241 kPa). If valve fails to function properly, it should be removed for inspection. Check for foreign material and contamination on valve and the seating area of valve body. Replace if defective.



## SOLENOID VALVE

Solenoid valve consists of a chambered body with an electric coil actuated cartridge valve.

If solenoid or solenoids fail to operate, first determine if problem is electrical or hydraulic. If valve is working properly, a click will be heard when solenoid coil is energized and valve stem opens. If no sound is heard, check solenoid coil by touching top of coil housing with a metallic object such as a pliers or screwdriver. If coil is working properly, coil housing will be strongly magnetized when energized. If voltage to coil is low it will be weakly magnetized when energized and no click will be heard.

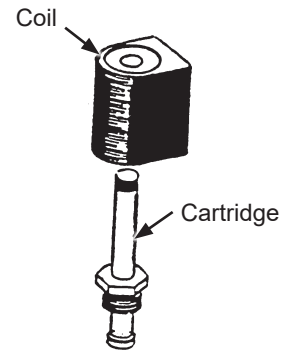

## HYDRAULIC DOWN FORCE PROPORTIONAL PRESSURE REDUCING/RELIEVING VALVE (TRUE DEPTH OPTION)

Proportional pressure relief valves are located on each row of planters equipped with the True Depth hydraulic down force system. *These valves are factory set and should require no additional adjustment.* Each valve acts independently and controls the fluid pressure on the cap end of the down force cylinder. Consult your Kinze Dealer for service.

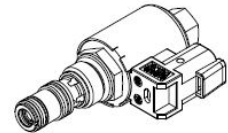

## PWM FLOW CONTROL VALVE

PWM flow control valve is used to control the fans on the Blue Drive equipped planters. The Blue Vantage System controls the valve, so no operator adjustment is required.

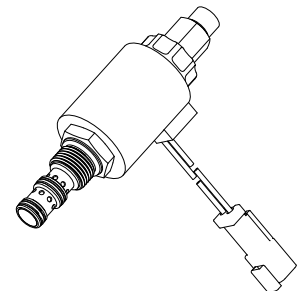

## ROW MARKER BEARING LUBRICATION OR REPLACEMENT

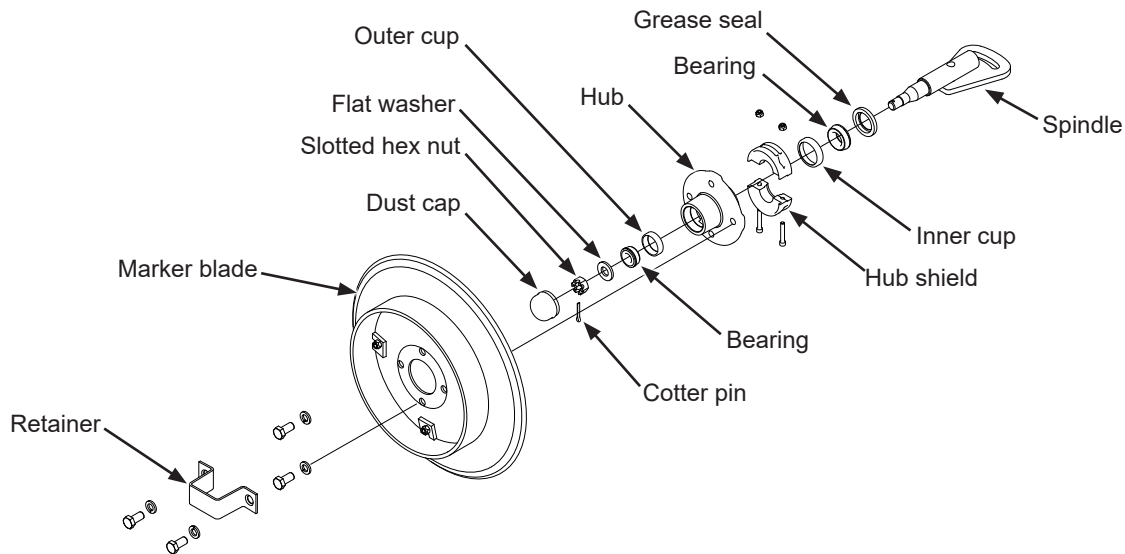

1. Remove retainer and marker blade.
2. Remove dust cap from hub.
2. Remove hub shield. Note direction of installation.
3. Remove cotter pin, slotted hex nut, and washer.
4. Slide hub from spindle.
5. Remove bearings and cups and discard if bearings are being replaced. Clean hub and dry. Remove bearings only and not cups if repacking.
6. Press in new bearing cups with thickest edge facing in. (Bearing replacement procedure only.)
7. Pack bearings with heavy duty wheel bearing grease thoroughly forcing grease between roller cone and bearing cage. Fill the space between the bearing cups in the hub with grease.
8. Install rubber seal into grease seal. Place inner bearing in place and press in new rubber seal/grease seal.
9. Clean spindle and install hub.
10. Install outer bearing, washer and slotted hex nut. Tighten slotted hex nut while rotating hub until there is some drag. This ensures all bearing surfaces are in contact. Back off slotted nut to nearest locking slot and install cotter pin.
11. Fill dust caps approximately  $\frac{3}{4}$  full of wheel bearing grease and install on hub.
12. Install hub shield.
13. Install marker blade and retainer on hub. Tighten hardware evenly.

## ROW MARKER TRANSPORT STAND ADJUSTMENT

Row marker transport stands must be correctly adjusted to allow marker cushion cylinders to function properly.

1. Raise markers to transport position.
2. Loosen mounting hardware to allow transport stands to drop down or remove transport stands.
3. With tractor engine shutoff, release hydraulic pressure on marker cylinders.
4. Locate transport stands so marker arm rests lightly on transport stand. When transport stands are correctly adjusted pin at rod end of cylinder should be loose enough to rotate and move back and forth in mounting slot.

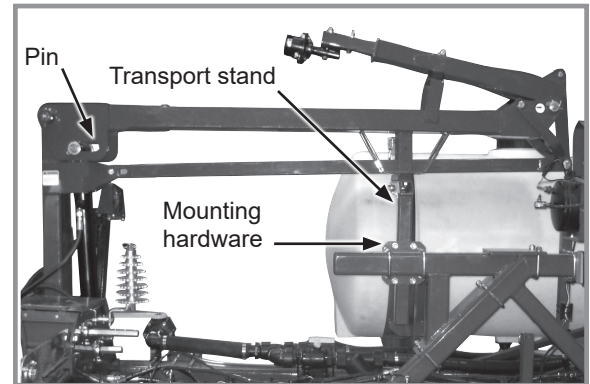

Row marker transport stand

## WHEEL BEARING REPACK OR REPLACEMENT

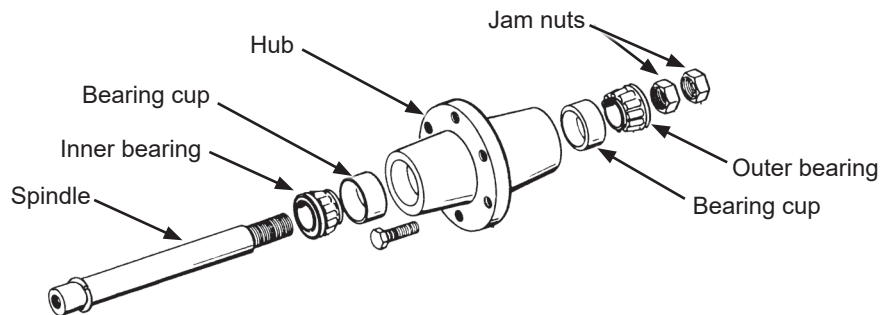

1. Raise tire clear of ground and remove wheel.
2. Remove double jam nuts and slide hub from spindle.
3. Remove bearings and cups and discard if bearings are being replaced. Clean hub and dry. Remove bearings only and not cups if repacking.
4. Press in new bearing cups with thickest edge facing in. (Bearing replacement procedure only.)
5. Pack bearings with heavy duty wheel bearing grease thoroughly forcing grease between roller cone and bearing cage. Fill space between bearing cups and hub with grease.
6. Place inner bearing in place.
7. Clean spindle and install hub.
8. Install outer bearing and jam nut. Tighten jam nut while rotating hub until there is some drag. This ensures all bearing surfaces are in contact. Back off jam nut  $\frac{1}{4}$  turn or until there is only slight drag when rotating hub. Install second jam nut to lock against first.
9. Install wheel on hub. Tighten hardware evenly.

## WEAR PAD FIELD REPLACEMENT/ADJUSTMENT

**NOTICE**

Over tightening wear pads will cause premature wear and excessive hydraulic lift pressures. Torque wear pads to 14 Nm. Do not over tighten wear pads.

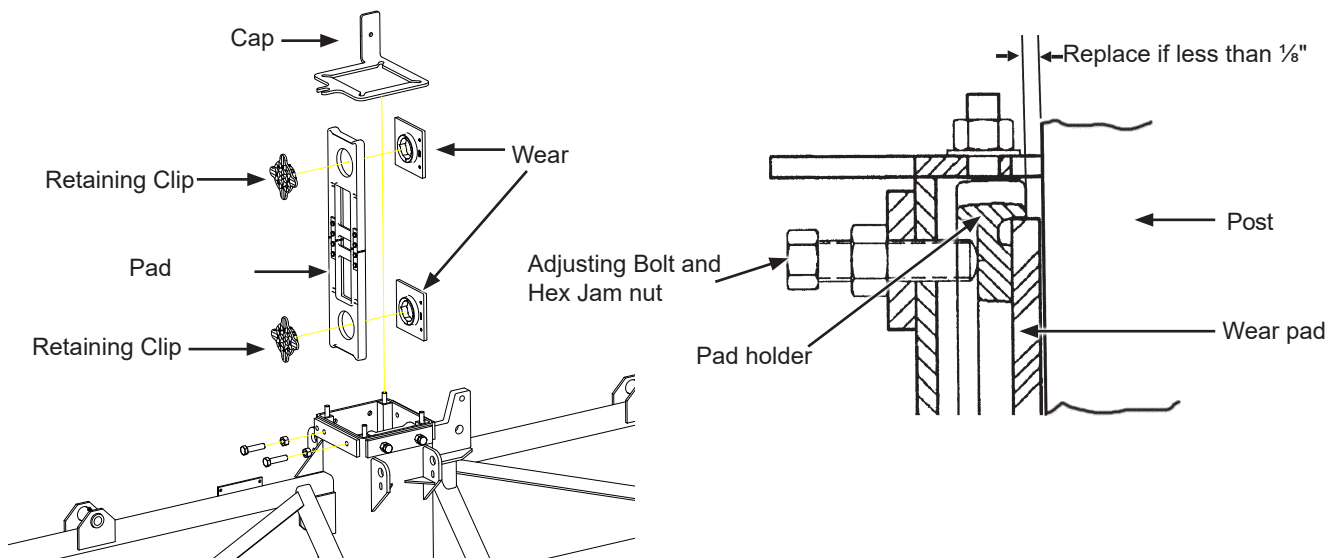

Planter center section is constructed around a steel tubular frame with four wear pad assemblies riding against a stainless steel clad center post. Two wear pads and retaining clips are held by a pad holder and locked in place by  $\frac{3}{4}$ " adjusting bolts and hex jam nuts. Inspect pads for wear and adjustment annually to ensure center section is stabilized and planter tracks properly. Pads should make full light contact with center post when properly adjusted. Too much preload on pads will cause hydraulic lift pressure to be higher than necessary or will not allow planter to raise when loaded.

1. Position planter on a level surface and place in raised field position.

**NOTE: Replace wear pad when worn to less than  $\frac{1}{8}$ ".**

2. Visually check four upper wear pads. Each wear pad should lightly contact stainless steel clad center post.
3. Place planter in raised transport position, install all safety lockups and visually check four lower wear pads for light contact.
4. Remove lockup and lower planter to field operation position. Loosen cap mounting nuts to allow wear pad adjustment. Loosen hex jam nuts as needed.

**NOTE: Cap mounting nuts MUST be loosened before adjusting wear pads.**

5. Tighten pad adjusting bolts, back off, and then torque wear pads to 14 Nm. Hold adjusting bolt from turning and torque hex jam nuts to 271 Nm.
6. Operate to full height on post and recheck for zero clearance.

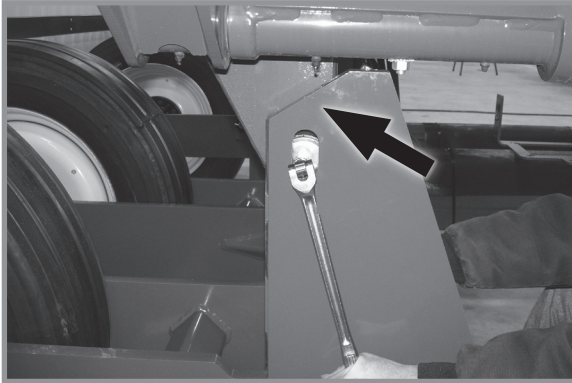
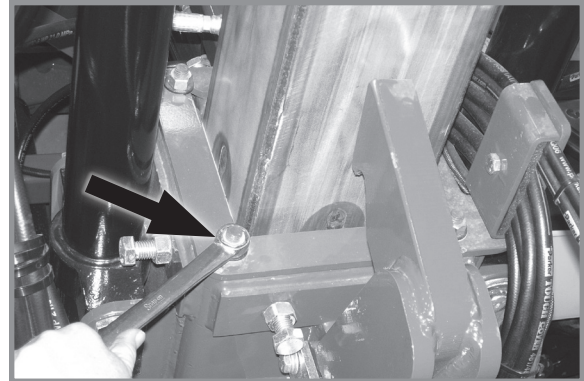
**MAJOR PAD ADJUSTMENT****Loosen cam rollers****Loosen four cap mounting nuts**

1. Loosen cam rollers so they move freely.
2. Lower planter to field operation position and release wing locks. Eliminate all uplift on planter frame by backing off row unit down pressure springs and uplift on any other planter attachments.
3. Check position of center frame to axle cam roller guides. Gap between guides and frame should be the same side to side. Gap on back sides of roller guide should be equal on both sides. Final adjustment will be done later.
4. Loosen four cap mounting nuts.

**NOTE: Cap mounting nuts MUST be loosened before adjusting wear pads.**

5. Loosen hex jam nuts and use pad adjusting bolts to position frame to center correctly.

**NOTICE**

**Over tightening wear pads will cause premature wear and excessive hydraulic lift pressures. Torque wear pads to 14 Nm. Do not over tighten wear pads.**

6. Tighten pad adjusting bolts, back off, and then torque wear pads to 14 Nm. Hold adjusting bolt from turning and torque hex jam nuts to 271 Nm.
7. Tighten cap mounting nuts.
8. Reset row unit down pressure and other attachments.

## PAD REPLACEMENT



**WARNING**



Improperly operating or working on this equipment could result in death or serious injury. Read and follow all instructions before operating or working on this equipment.

- a. Loosen cam rollers so they move freely as shown.
- b. Lower planter to field operation position and release wing locks.
- c. Eliminate all uplift on planter frame by backing off row unit down pressure springs and uplift on any attachments.
- d. Remove safety hook.
- e. Disconnect hydraulic hose, remove nut on bulkhead fitting, and remove fitting from cap.
- f. Loosen four cap mounting nuts and remove pad holder cap.
- g. Loosen pad hex jam nuts, back pad bolts out, and remove four pad holder assemblies. Remove and discard old pads.

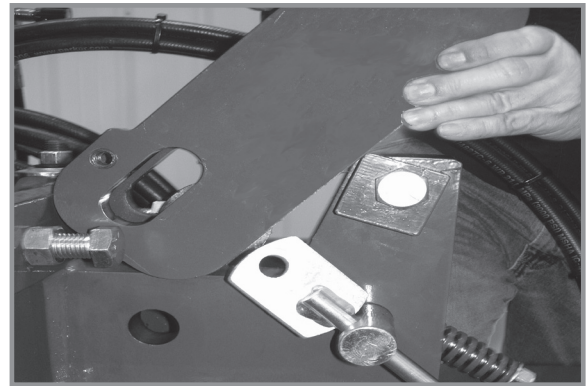

**Removing safety hook**

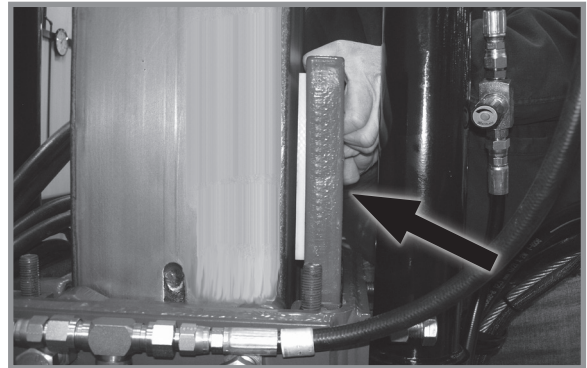

**Removing Pad Holder Assembly**



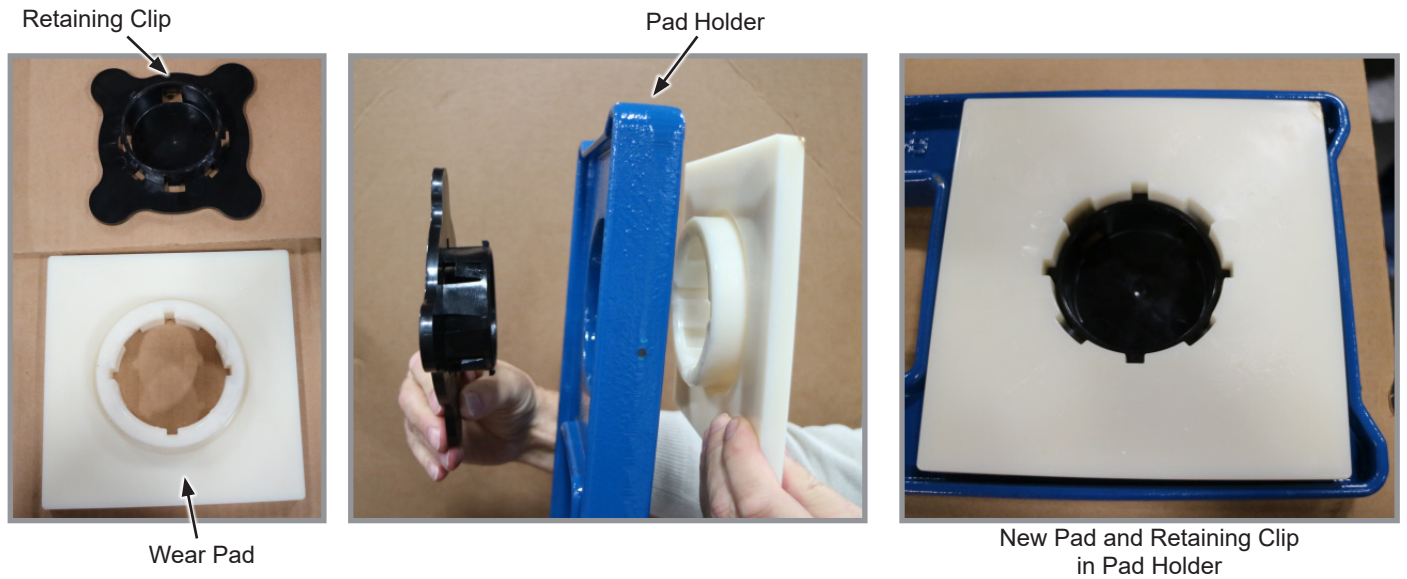

- h. Install new pad using retaining clip. Repeat for other side of pad holder.
- i. Reinstall pad holder in center section.

### NOTICE

Over tightening wear pads will cause premature wear and excessive hydraulic lift pressures. Torque wear pads to 14 Nm. Do not over tighten wear pads.

- j. Tighten pad adjusting bolts, back off, and then torque wear pads to 14 Nm. Hold adjusting bolt from turning and torque hex jam nuts to 271 Nm.
- k. Reinstall cap and tighten cap mounting nuts.
- l. Reinstall hydraulic hose, fittings, and safety hook.

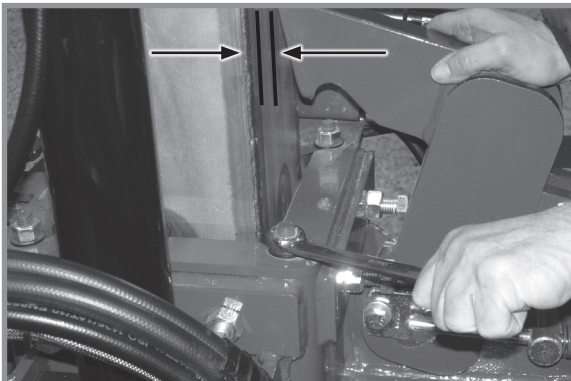

Adjust safety hook clearance to 6.4 mm - 9.5 mm

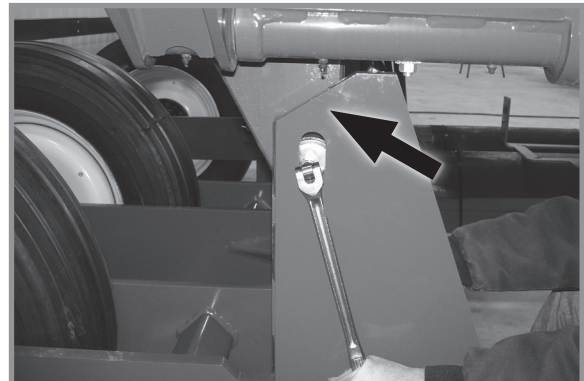

Adjust and tighten cam roller

- m. Adjust stop on safety hook to 6.4 mm- 9.5 mm clearance.
- n. Rotate cam roller against front guide and tighten to 149 Nm. Make sure gap between roller guide and center frame are equal on both sides. Raise planter out of roller guides and lower back down into roller guides to be sure roller guides operate smoothly. Adjust rotation cylinder rod as needed.
- o. Reset row unit down pressure and other attachments.

## TRACTOR MOUNTED PTO PUMP AND OIL COOLER OPTION

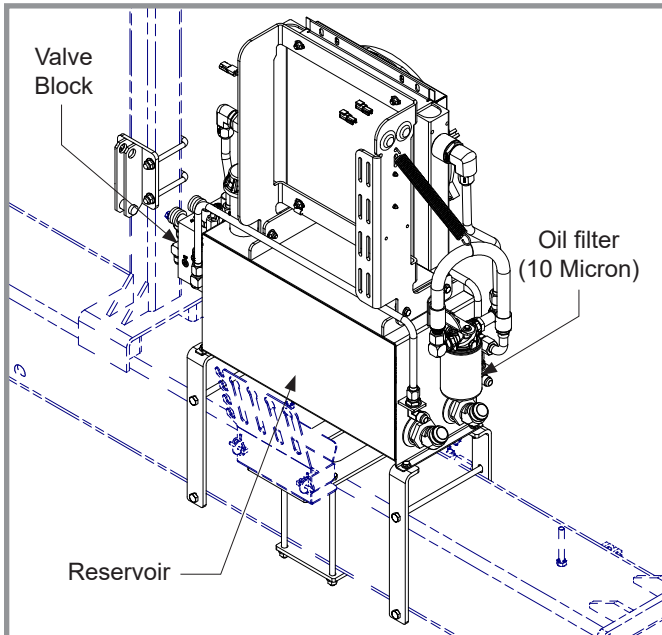

**Dual Stage -- Vacuum/Bulk Fill**

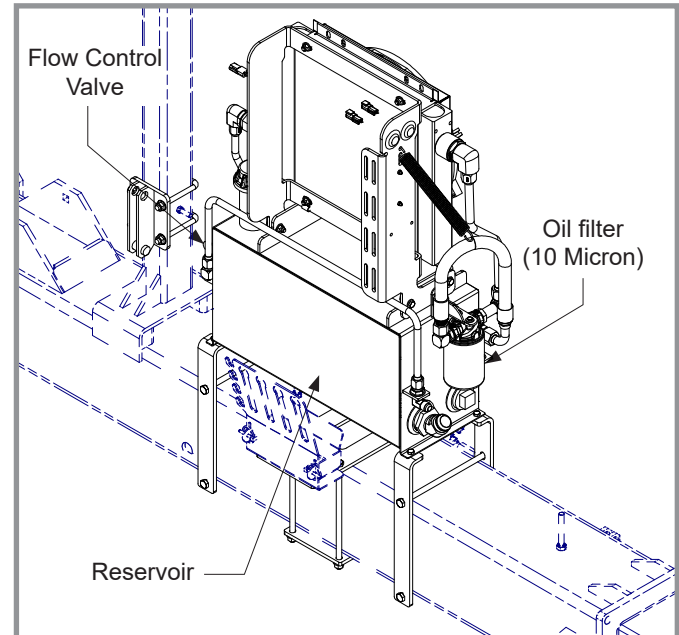

**Single Stage -- Vacuum/Row Hoppers**

**Note:** Clean and grease PTO shaft coupling with high-pressure industrial coupling grease (Chevron coupling grease or equivalent) meeting AGMA CG-1 and CG-2 standards each time driveshaft is installed or premature wear and equipment failure can occur.

*Chevron® trademark is owned by Chevron Products Company. AGMA is the acronym for American Gear Manufacturers Association.*

Drain reservoir and change filter annually.

Fill system with SAE 10W-20 multigrade wide temperature range transmission hydraulic fluid. Reservoir capacity is approximately 12 gallons (45.4 L).

Start up procedure after oil change:

1. Start system and run with tractor at idle and fan turned off for about 1-2 minutes. Switch fan to full speed and run with tractor at idle for 1-2 minutes.
2. Check reservoir fluid level and fill as required. Hydraulic fluid level should not be within 1"-2" from top of reservoir after pump has run and hydraulic hoses have been primed to allow fluid to expand when heated.
3. Bring tractor to full PTO speed and adjust flow control for desired system pressure.

**Note:** periodically check and clean oil coolers.

## TRUE DEPTH HYDRAULIC SYSTEM SERVICING



True Depth Pressure Gauge



### WARNING

Remove all hydraulic power sources and verify True Depth pressure gauge reads zero before servicing.

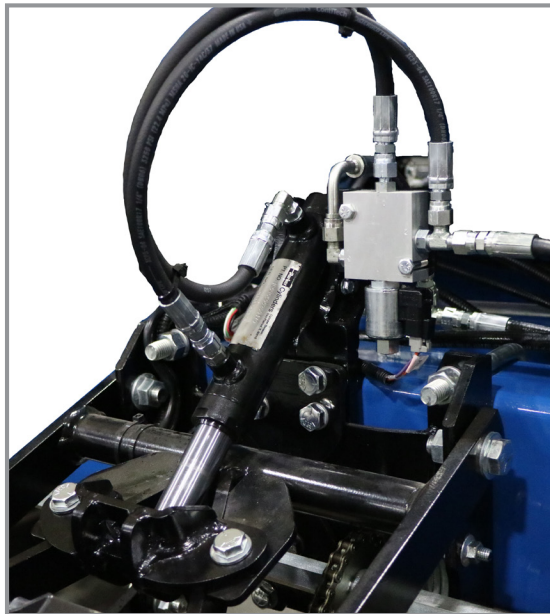

True Depth Cylinder



### WARNING

Flow out of the rod end port of the cylinder must not be restricted when pressurizing cap end port as 4.5:1 pressure intensification will occur on the rod end of the cylinder potentially resulting in failure of the cylinder and loss of containment of the piston rod assembly.



True Depth Filter

**TRUE DEPTH FILTER**

Replace filter cartridge annually, every 100 hours of operation, or when the clogging indicators point out the limit pressure drop created inside the filter.

To replace the cartridge:

1. Stop the system in "Machine Stopped" status
2. Secure any shut-off valves on the hydraulic circuit.
3. Unscrew the filter container (1).
4. Remove the clogged filtering cartridge (5), making sure no residual particles have settled in the bowl bottom.
5. Make sure the O-ring (2-4) and the anti-extrusion ring (3) are not damaged, otherwise replace them and consequently position the new ones correctly.
6. Insert the new filtering cartridge, lubricating the sealing O-ring beforehand.
7. Screw the container tight (1) making sure the threading is screwed correctly. Tighten to a tightening torque of 65 Nm.
8. Start the machine for a few minutes.
9. Make sure there are no leaks.

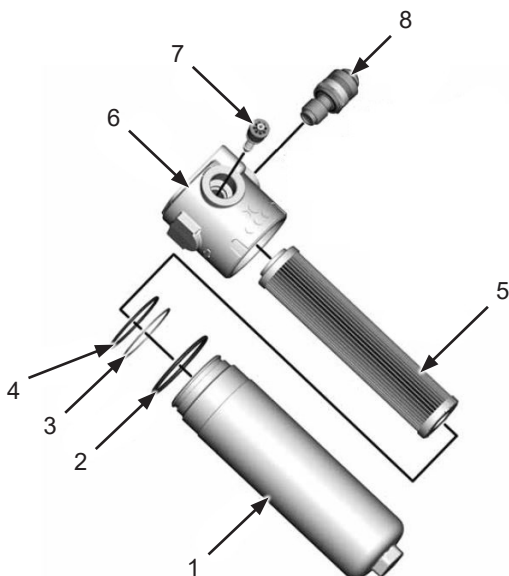

1. Filter Bowl
2. External O-Ring
3. Anti-extrusion ring
4. Sealing O-Ring
5. Filtering Element
6. Filter Head
7. By-pass valve
8. Visual differential indicator

True Depth Cylinder

## PREPARATION FOR STORAGE

Store planter in a dry sheltered area if possible.

Remove all trash wrapped on sprockets or shafts and remove dirt that can draw and hold moisture.

Clean all drive chains and coat with a rust preventative spray or remove chains and submerge in oil.

Lubricate planter and row units at all lubrication points.

Inspect planter for parts that in need of replacement and order during “off” season.

Make sure all seed and granular chemical hoppers are empty and clean.

Remove seed discs from seed meters, clean and store meters in a rodent-free, dry area with discs removed. Store seed discs vertically on a dowel or pipe.

Remove vacuum hose from each seed meter. Operate vacuum fan at full hydraulic flow from tractor for two minutes to clear manifolds, hoses and fittings of dust and debris.

Clean breather on analog vacuum and pressure gauges.

Disassemble, clean and grease all U-joint slides.

Grease or paint disc openers/blades and row marker disc blades to prevent rust.

Flush liquid fertilizer tanks, hoses and metering pump with clean water. See “Piston Pump Storage” if applicable.

Empty dry fertilizer hoppers. Clean hoppers. Disassemble and clean metering augers. Reassemble, coating all metal parts with rust preventative.

Bulk Fill System:

- Clean out bulk fill hopper, entrainment assembly, and delivery hoses.
- Disconnect delivery hoses from entrainer ports. Install small orange caps onto ports. Attach hoses to caps.
- Disconnect delivery hoses from air dissipator at each row unit. Install large orange caps. Attach hoses to caps.
- Check all bolts and fasteners used to assemble and attach entrainment device are tight (if applicable).
- Loosen knobs on entrainer cleanout doors to remove pressure from door gaskets.
- Inspect all seed delivery hoses and replace any that are worn, cut, or cracked.

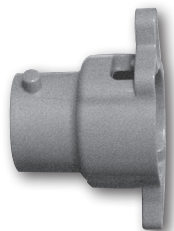

Entrainer cap

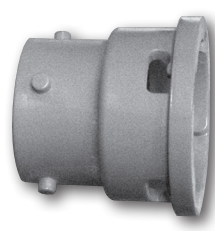

Air dissipator cap

## PNEUMATIC DOWN PRESSURE AIR COMPRESSOR TANK

Moisture should be drained daily from the tank. Tank should be drained completely for storage.

To drain tank, locate drain plug on the bottom of tank. Stand off to the side of tank and pull cable attached to drain.

**NOTE: If moisture is not drained from tank rust particles will form inside tank.**

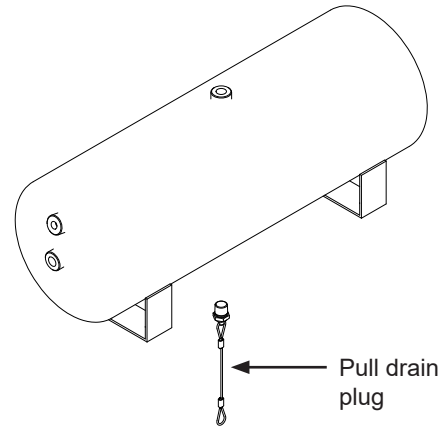

## FERTILIZER CHECK VALVE CLEANING AND REPAIR

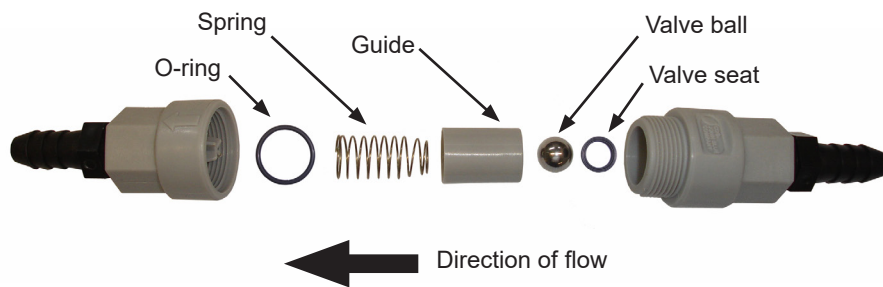

1. Unscrew valve body and separate halves. Note direction and location of parts.
2. Clean and inspect parts. Flush with clean water. Replace damaged parts.
3. Reassemble exactly as shown. O-ring and valve seat must be firmly in place inside each half of valve body.

## PISTON PUMP MAINTENANCE

- Check oil daily and fill crankcase to proper level with a quality grade SAE 90 weight gear oil. With the pump sitting level, the oil should be within 1/2" of the bottom of the hole on back of crankcase. You may use along wire or zip tie as a dipstick to check the level – some length is required due to the hole's depth.
- Lubricate all grease zerks on roller chain sprocket spacer, outboard cover plate, crankshaft end, and at stuffing box flange daily. Fill zerks until grease is visibly seen seeping from mating parts. For the stuffing box flange zerk, grease will be seen seeping from the vent on the opposite side of the flange.
- Pump oil should be changed seasonally or more often in extreme use conditions.
- Visually inspect sprocket and drive chain daily for excessive wear or corrosion. Lubricate chain regularly to reduce corrosion. Chain alignment must be straight.

## PISTON PUMP STORAGE

### NOTICE

**Keep air out of the pump! This is the only way to prevent corrosion. Even for short periods of storage, the entrance of air into the pump causes RAPID and SEVERE CORROSION. Freezing temperatures can cause the fluid or water to freeze internally to the pump, which can cause severe damage to the wet-end castings.**

### OVERNIGHT

Suspension fertilizer must be flushed from the pump for ANY storage period. For Clear Liquids:

1. Steady or rising temperatures: leave pump and hoses filled with solution. DO NOT DRAIN nor admit air to the pumps.
2. Cooling weather: (solution likely to salt out), fill pump with water and leave filled. DO NOT admit air.
3. Freezing temperature: fill pump with RV-antifreeze and leave filled, DO NOT admit air.

### ONE TO TWO WEEKS

ACCEPTABLE: Flush pump thoroughly with 5 to 10 gallons of a solution that will neutralize the liquid last pumped (refer to that manufacturer's instructions). Fill with clean water and DO NOT DRAIN. Keep pump sealed to exclude air. If freezing temperatures are remotely possible, the winter storage procedure (see below) must be used to avoid damage to the pump castings.

PREFERRED: Flush pump as detailed above. IMMEDIATELY fill all passages in pump with straight RV antifreeze which contains a rust inhibitor. Place 1-1/2" NPT PVC plugs in the suction and discharge fittings to keep pump full and exclude air.

### WINTER STORAGE

1. Flush pump as detailed above.
2. With pump set on 10, draw in straight RV-antifreeze until the discharge is clean. If system utilizes a flow divider (FD), pump the RV-antifreeze through the FD manifold until it is seen in the

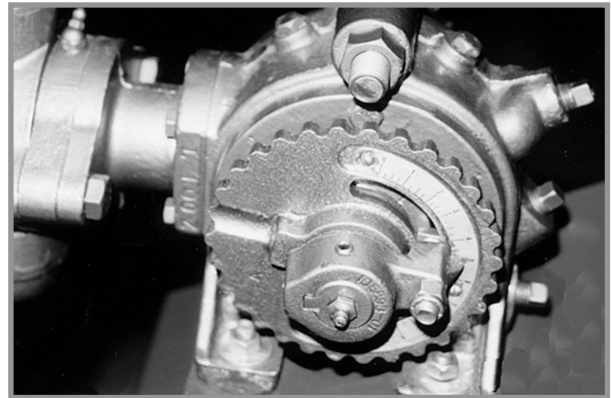
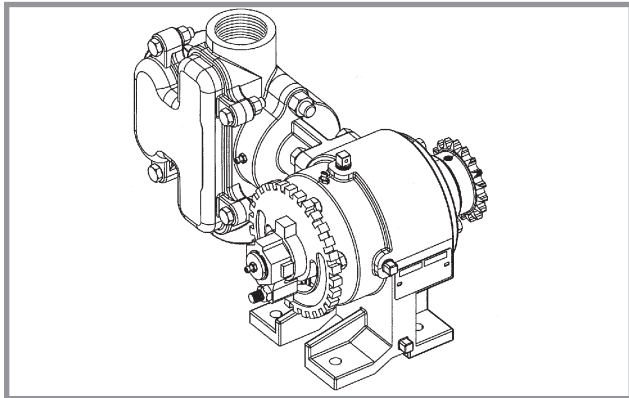

Liquid fertilizer piston pump

**DIAPHRAGM LIQUID FERTILIZER PUMP MAINTENANCE**

<b>NOTICE</b>	<b>Before doing any kind of maintenance on the liquid fertilizer pump, make sure that the pump is shut off and the fertilizer system is depressurized.</b>
---------------	--

STRAINER MAINTENANCE

Diaphragm liquid fertilizer pump strainers need to be cleaned **daily** to ensure smooth operation and prevent system malfunctions.

**Suction Strainer:**

When the planter is raised, look underneath the pump for the suction strainer. Disassemble the strainer by twisting the bottom part until it comes loose, then remove it. Take out the mesh strainer and clean it thoroughly with water. Re-assemble the strainer.

If the mesh strainer or the o-ring are damaged, or if the strainer is leaking after cleaning, order a replacement strainer from your service dealer.

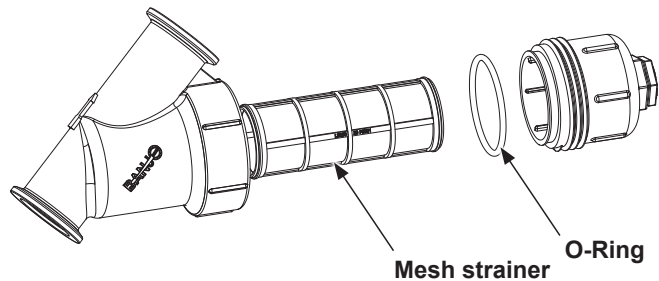
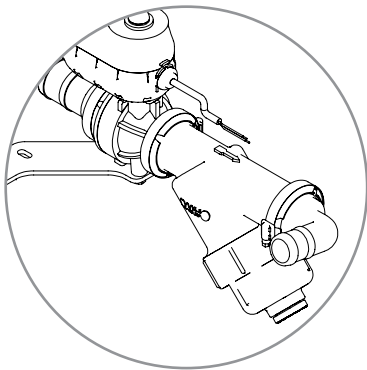

**Pressure Strainer:**

When the planter is raised, look underneath the pump for the pressure strainer. Disassemble the strainer by twisting the bottom part until it comes loose, then remove it. Take out the mesh strainer and clean it thoroughly with water. Re-assemble the strainer.

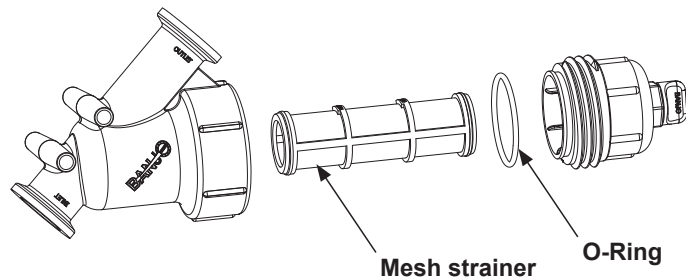
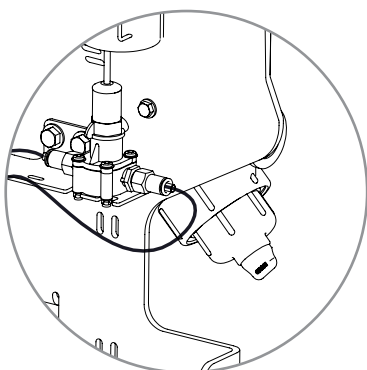



---

**OTHER DIAPHRAGM PUMP MAINTENANCE INTERVALS**

MAINTENANCE INTERVAL	ACTION
Each time used.	Check the level and the status of the oil. Check the suction filter and clean if necessary.
Every 50 hours.	Check if the suction line is intact. Check if the pump is tightly fastened to the chassis of the machine. <u>Should the pump not be securely fastened, do not use the machine for any reason.</u>
Every 300 hours	Check the suction and delivery valves (check more frequently if liquids are used with suspended abrasive particles).
At the end of every planting season or once a year.	Check the diaphragms and replace, if necessary (we suggest replacing all the diaphragms of the pump regardless of their condition if aggressive chemicals are used). Check the damper diaphragm (when present) and replace it, if necessary. Replace the oil (oil must be replaced at every diaphragm substitution). Check if the pump screws are tight.

**BATTERY CARE**

<b>NOTICE</b>	<b>Read and follow all manufacturer labels and instructions.</b>
---------------	--

Battery Specifications	
Chemistry:	Wet lead acid (low maintenance)
Voltage:	12.00 V
Capacity:	>7.00 Ah
Weight:	15.3 lbs (6.9 kg)
Length:	194 mm
Width:	126 mm
Height:	183 mm
Termination:	Top post L Terminal

BEFORE PLANTING SEASON

- Check and clean all connections.
- Fully charge batteries before installing into the planter.
- Batteries more than two years old should be load checked.
- Reinstall batteries or connect the negative ground cables.

PREPARATION FOR STORAGE

Planter batteries that are stored for more than one month should be cared for as follows:

- Remove the batteries or disconnect the negative ground cable.
- Fully charge batteries before storing.
- Store in a cool and dry location.
- Keep from freezing.

<b>NOTICE</b>	<b>When replacing batteries, replace both at the same time. NEVER replace one battery at a time. Batteries in Power Pack must be identical to one another.</b>
---------------	--

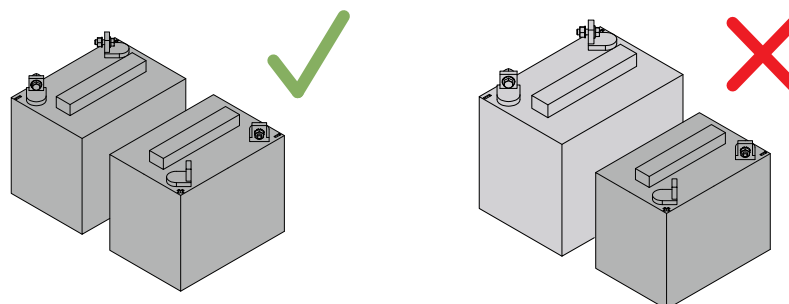

**ELECTRICAL CONTROL CONSOLE SCHEMATIC**

**NOTE: Disconnect control console from tractor battery before doing any electrical work. Keep wiring harnesses away from high temperature areas or sharp edges. DO NOT route wiring harnesses along battery cables. Use cable ties to keep wire harness away from moving parts on tractor and planter. Be sure tractor frame ground connections are clean to provide good electrical contact.**

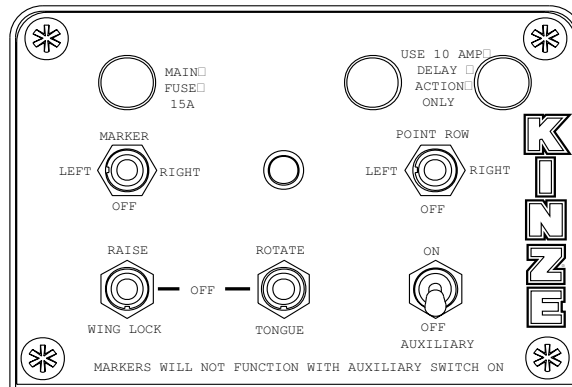
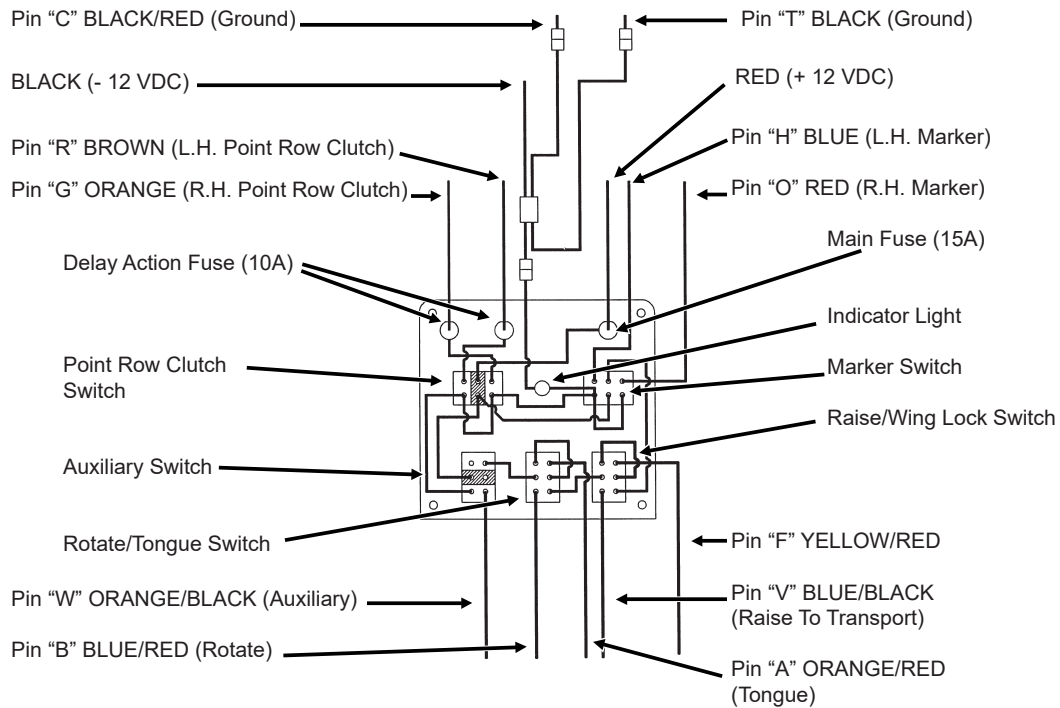

**NOTE 1. Operating marker or point row switch in either direction lights panel light.**

**NOTE 2. Point row clutch switch operates independently from rest of control box.**

**NOTE 3. Power to marker switch is fed through auxiliary switch and two transport function switches. Operating any switch in lower row disables marker function and turns off panel light. (If point row clutch switch is OFF.)**

**ELECTRICAL WIRING HARNESS SCHEMATIC (On Tractor)**

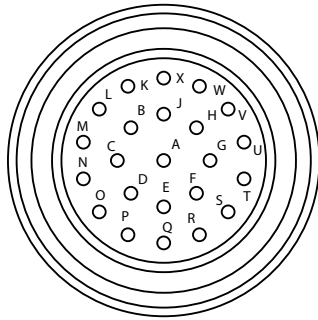

**23 Socket Capacity**

Pin No.	Wire Color	Function	Wire Ga.
A	Orange/Red	Tongue Raise	14
B	Blue/Red	Fold	14
C	Black/Red	Ground	14
D	White	Monitor B 12V	14
E	Green	Monitor B DATA	14
F	Yellow/Red	Wing Lock	14
G	Orange	Point Row - Right	12
H	Blue	Marker - Left	14
J	Black	Monitor B Ground	14
K	White	Monitor A 12V	14
L	Green	Monitor A Data	14
M	Black	Monitor A Ground	14
N	---	---	---
O	Red	Marker - Right	14
P	---	---	---
Q	---	---	---
R	Brown	Point Row - Left	12
S	Yellow	Reduced Rate - Left	12
T	Black	Ground	12
U	Red/Black	Reduced Rate - Right	12
V	Blue/Black	Raise to Transport	14
W	Orange/Black	Auxiliary	14
X	---	---	---

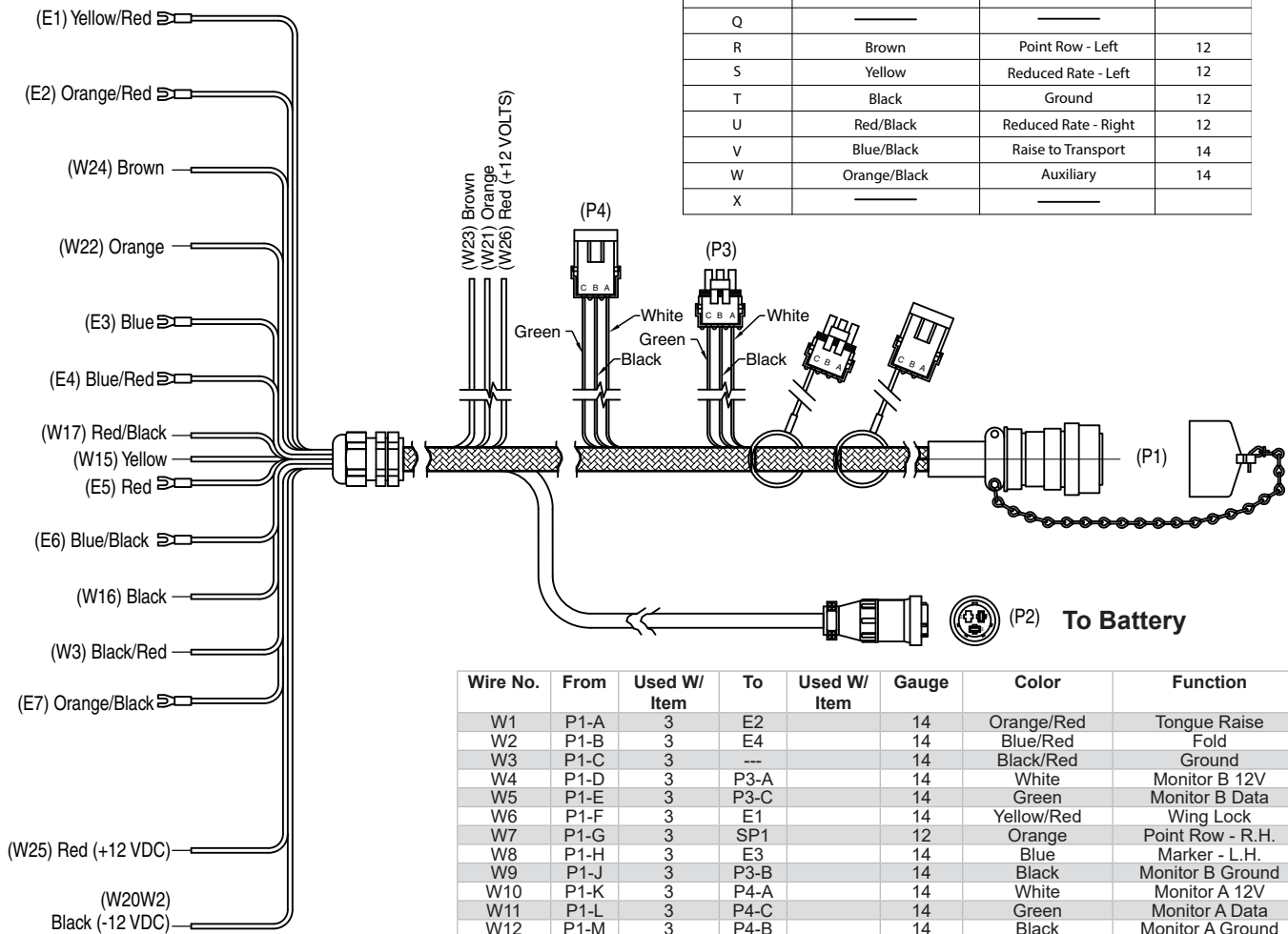

Wire No.	From	Used W/ Item	To	Used W/ Item	Gauge	Color	Function
W1	P1-A	3	E2		14	Orange/Red	Tongue Raise
W2	P1-B	3	E4		14	Blue/Red	Fold
W3	P1-C	3	---		14	Black/Red	Ground
W4	P1-D	3	P3-A		14	White	Monitor B 12V
W5	P1-E	3	P3-C		14	Green	Monitor B Data
W6	P1-F	3	E1		14	Yellow/Red	Wing Lock
W7	P1-G	3	SP1		12	Orange	Point Row - R.H.
W8	P1-H	3	E3		14	Blue	Marker - L.H.
W9	P1-J	3	P3-B		14	Black	Monitor B Ground
W10	P1-K	3	P4-A		14	White	Monitor A 12V
W11	P1-L	3	P4-C		14	Green	Monitor A Data
W12	P1-M	3	P4-B		14	Black	Monitor A Ground
W13	P1-O	3	E5		14	Red	Marker - R.H.
W14	P1-R	3	SP2		12	Brown	Point Row - L.H.
W15	P1-S	3	---		12	Yellow	Reduced Rate - L.H.
W16	P1-T	3	---		12	Black	Ground
W17	P1-U	3	---		12	Red/Black	Reduced Rate - R.H.
W18	P1-V	3	E6		14	Blue/Black	Raise to Transport
W19	P1-W	3	E7		14	Orange/Black	Auxiliary
W20W1	P2-1	---	SP3		12	Red	12 VDC+
W20W2	P2-3	---	---		12	Black	12 VDC-
W21	SP1	---	---		12	Orange	Point Row - R.H.
W22	SP1	---	---		12	Orange	Point Row - R.H.
W23	SP2	---	---		12	Brown	Point Row - L.H.
W24	SP2	---	---		12	Brown	Point Row - L.H.
W25	SP3	---	---		12	Red	12 VDC+
W26	SP3	---	---		12	Red	12 VDC-

**ELECTRICAL WIRING HARNESS SCHEMATIC (On**

**23 Socket Capacity**

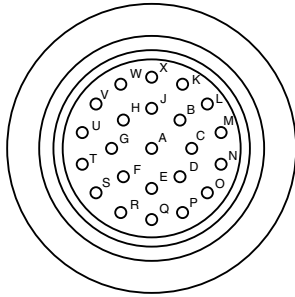

Pin No.	Wire Color	Function	Wire Ga.
A	Orange/Red	Tongue Retract/Extend	14
B	Blue/Red	Fold	14
C	Black/Red	Ground	14
D	White	Monitor B 12V	14
E	Green	Monitor B Data	14
F	Yellow/Red	Wing lock	14
G	Orange	PT. Row - Right	12
H	Blue	Marker - Left	14
J	Black	Monitor B Ground	14
K	White	Monitor A 12V	14
L	Green	Monitor A Data	14
M	Black	Monitor A Ground	14
N	---	---	---
O	Red	Marker - Right	14
P	---	---	---
Q	---	---	---
R	Brown	PT. Row - Left	12
*S	Yellow	Reduced Rate - Left	12
T	Black	Ground	12
*U	Red/Black	Reduced Rate - Right	12
V	Blue/Black	Raise to Transport	14
W	Orange/Black	Auxiliary	14
X	---	---	---

**VALVE BLOCK -  
Located on rear  
center frame**

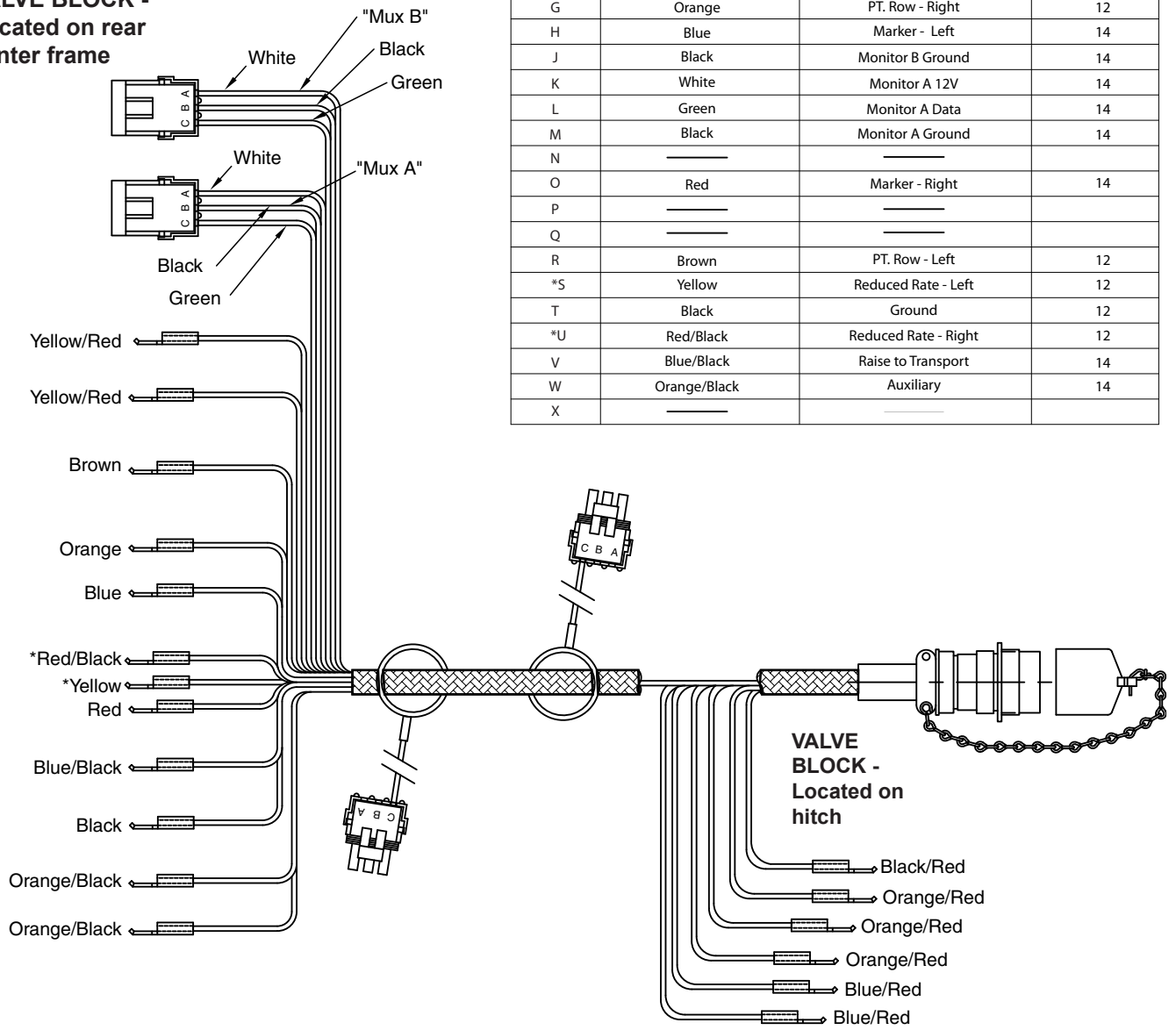

**ELECTRICAL CONTROL CONSOLE CONNECTIONS - AG LEADER**

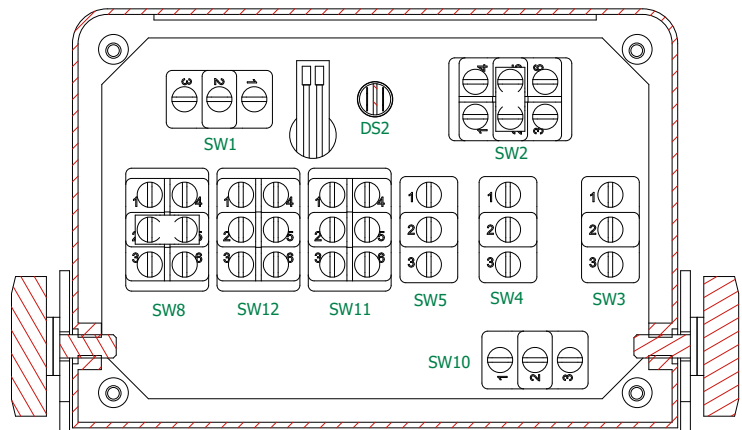
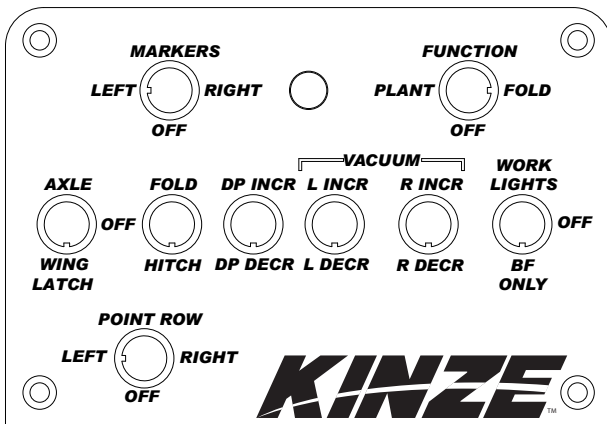

**Wire Hookup Chart**

Reference Designator	From	To	Color	Function
JP1	SW2-2	SW2-5		Jumper 1
JP2	SW8-2	SW8-5		Jumper 2
W1	E1	SW2-1	Orange	Marker Left
	E2	SW2-3	White/Orange	Marker Right
	E3	SW3-3	Brown	Axle
	E4	SW3-1	White/Brown	Wing Hooks
	E5	SW4-3	Gray	Fold
	E6	SW4-1	White/Gray	Hitch
	E7	SW5-3	Green	PDP Increase
	E8	SW5-1	White/Green	PDP Decrease
	W9	TB4	Blue	L VAC Increase
	W10	TB5	White/Blue	L VAC Increase
	W11	TB6	Violet	R VAC Increase
	W12	TB7	White/Violet	R VAC Decrease
	E13	SW8-3	Yellow	Work Light - Tank
	E14	SW8-6	White/Yellow	Work Light - Marker
	E15	SW10-1	Pink	Point Row L
	E16	SW10-3	White/Pink	Point Row R
	W15	TB2	Black	Tractor Ground
	W16	TB2	Black	Tractor Ground
W17W2	TB2	Black	Tractor Ground	
W18	TB1	Red	Tractor Power	
W2	SW3-2	SW4-2	Red	Jumper Wire
W3	SW8-5	SW12-2	Red	Jumper Wire
W4	SW11-2	SW12-2	Red	Jumper Wire

(Continued on next page)

Wire Hookup Chart (Continued)				
Reference Designator	From	To	Color	Function
W5	SW5-2	SW11-2	Red	Jumper Wire
W6	SW8-1	SW8-3	Red	Jumper Wire
W7	SW1-3	SW2-5	Red	Jumper Wire
W8	SW1-1	SW4-2	Red	Jumper Wire
W9	SW1-2	TB1	Red	Tractor Power
W10	SW8-2	TB1	Red	Tractor Power
W11	SW2-4	TB3	Red	Marker LED
W12	SW2-6	TB3	Red	Marker LED
W13	DS2(+)	TB3	Red	Marker LED
W14	DS2(-)	SW12-5	Black	Tractor Ground
W15	SW10-2	TB1	Red	Tractor Power
W16	SW11-3	TB4	Blue	L VAC Increase
W17	SW11-4	TB4	Blue	L VAC Increase
W18	SW11-1	TB5	White/ Blue	L VAC Decrease
W19	SW11-6	TB5	White/ Blue	L VAC Decrease
W20	SW12-3	TB6	Violet	R VAC Increase
W21	SW12-4	TB6	Violet	R VAC Increase
W22	SW12-1	TB7	White/ Violet	R VAC Decrease
W23	SW12-6	TB7	White/ Violet	R VAC Decrease
W24	SW11-5	TB2	Black	Tractor Ground
W25	SW11-5	SW12-5	Black	Jumper Wire
U1	Red	TB1	Red	Tractor Power
	Black	TB2	Black	Tractor Ground
	Yellow	DS1-1	Yellow	Display Light
	Orange	DS1-2	Orange	Display Light

**VALVE BLOCK - LOCATED ON HITCH**

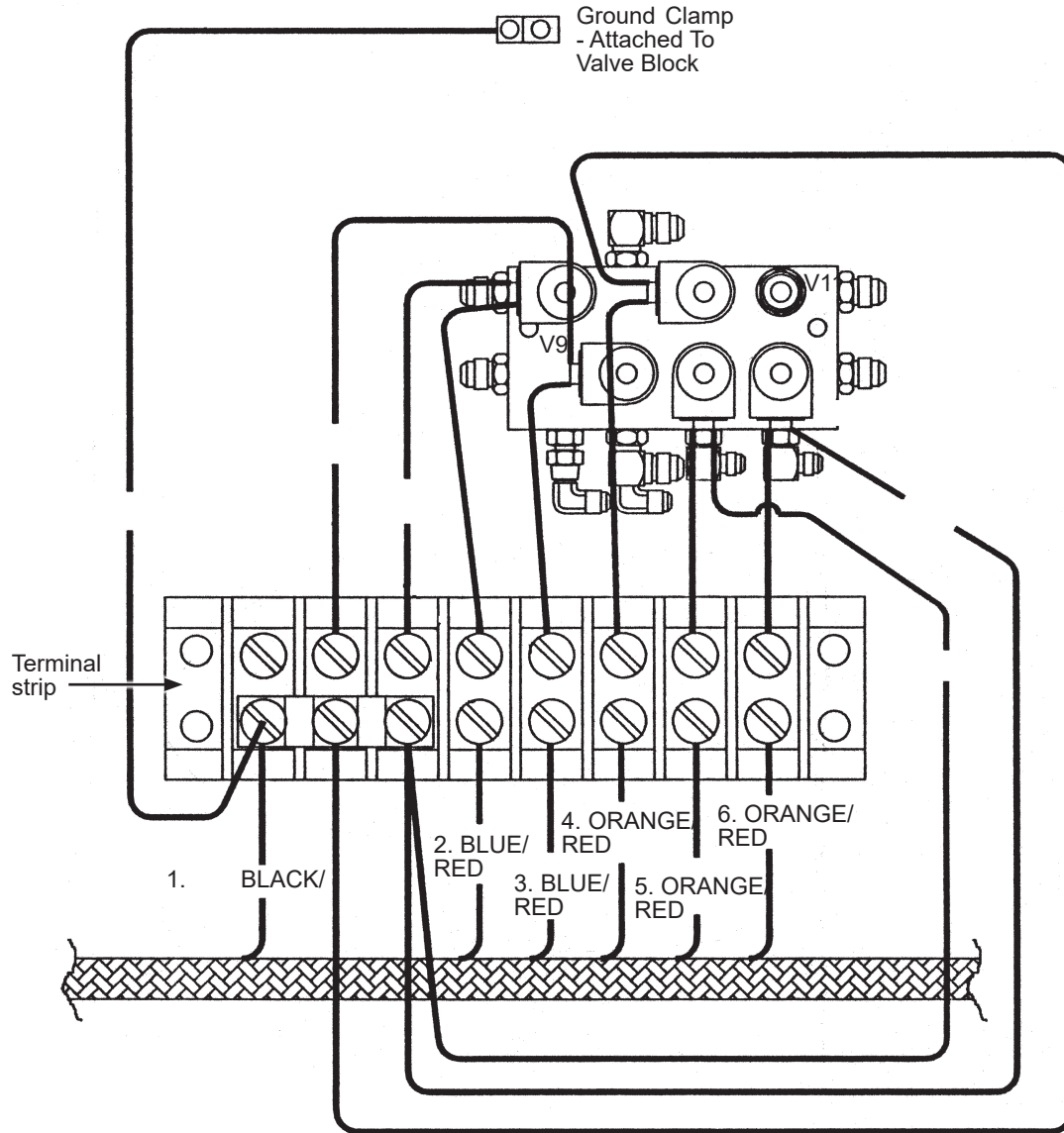

- 1. BLACK/RED - Pin "C" (Ground)
- 2. BLUE/RED - Pin "B" (Rotate) - Port V9
- 3. BLUE/RED - Pin "B" (Rotate) - Port V12
- 4. ORANGE/RED - Pin "A" (Tongue) - Port V10
- 5. ORANGE/RED - Pin "A" (Tongue) - Port V13
- 6. ORANGE/RED - Pin "A" (Tongue) - Port V14



## VALVE BLOCK - LOCATED ON REAR CENTER FRAME

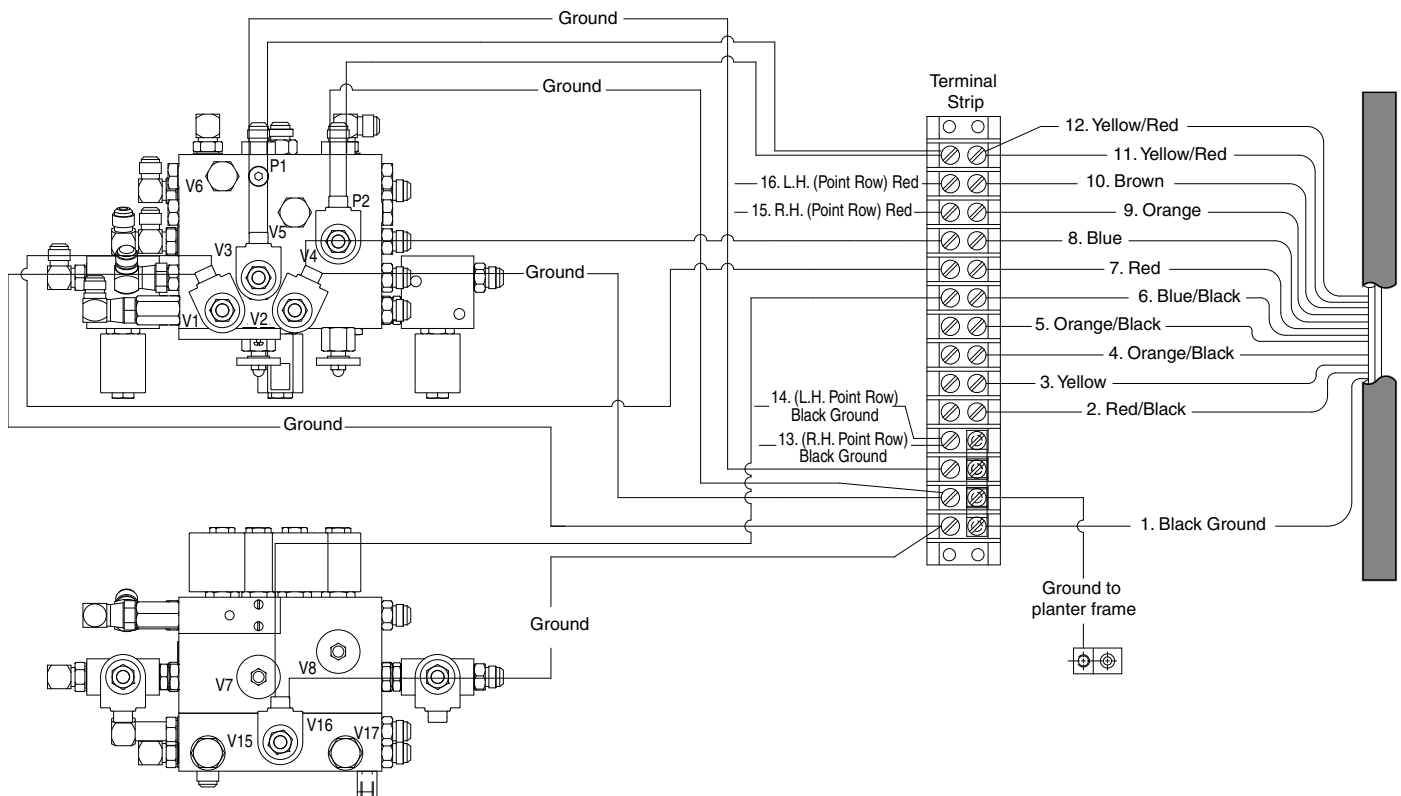

1. BLACK - Pin "T" (Ground)
2. RED/BLACK - Pin "U" (R.H. Two-Speed Clutch)\*
3. YELLOW - Pin "S" (L.H. Two-Speed Clutch)\*
4. ORANGE/BLACK - Pin "W" (Auxiliary) - Ports V5 & V6
5. ORANGE/BLACK - Pin "W" (Auxiliary) - Ports V5 & V6
6. BLUE/BLACK - Pin "V" (Raise To Transport) - Port V16
7. RED - Pin "O" (R.H. Marker) - Port V1
8. BLUE - Pin "H" (L.H. Marker) - Port V2
9. ORANGE - Pin "G" (R.H. Point Row Clutch)
10. BROWN - Pin "R" (L.H. Point Row Clutch)
11. YELLOW/RED - Pin "F" (Wing Lock) - Ports V3 & V4
12. YELLOW/RED - Pin "F" (Wing Lock) - Ports V3 & V4
13. BLACK - (R.H. Point Row Ground)
14. BLACK - (L.H. Point Row Ground)
15. RED - (R.H. Point Row)
16. RED - (L.H. Point Row)

## HYDRAULIC HOSE LIFE

**WARNING**

Pressurized hydraulic fluid can penetrate body tissue and result in death, serious infection, or other injuries. Fluid injected under skin must be **IMMEDIATELY** removed by a surgeon familiar with this type of injury. Make sure connections are tight and hoses and fittings are not damaged before applying system pressure. Leaks can be invisible. Keep away from suspected leaks. Relieve pressure before searching for leaks or performing any system maintenance.



Proper storage of hydraulic hoses can significantly increase the life of the hoses, for a period of three to five years. After this period, service life of hoses may decrease, depending on variables such as variances in rubber materials and storage environment. Refer to the guidelines below for best practices when storing.

- Store in a clean, cool and dry area
- Avoid direct sunlight or moisture
- Do not store near high power electrical equipment
- Avoid contact with corrosive chemicals
- Avoid ultraviolet light
- Avoid areas with obvious signs of insects or rodents

Unusually long periods of storage or poor storage environment may lead to performance issues or premature failure. Always inspect all hoses prior to use for extensive wear, cuts, or holes. If such flaws are identified, replace immediately to avoid potential failure, property damage or bodily injury.

HYDRAULIC SYSTEM SCHEMATIC

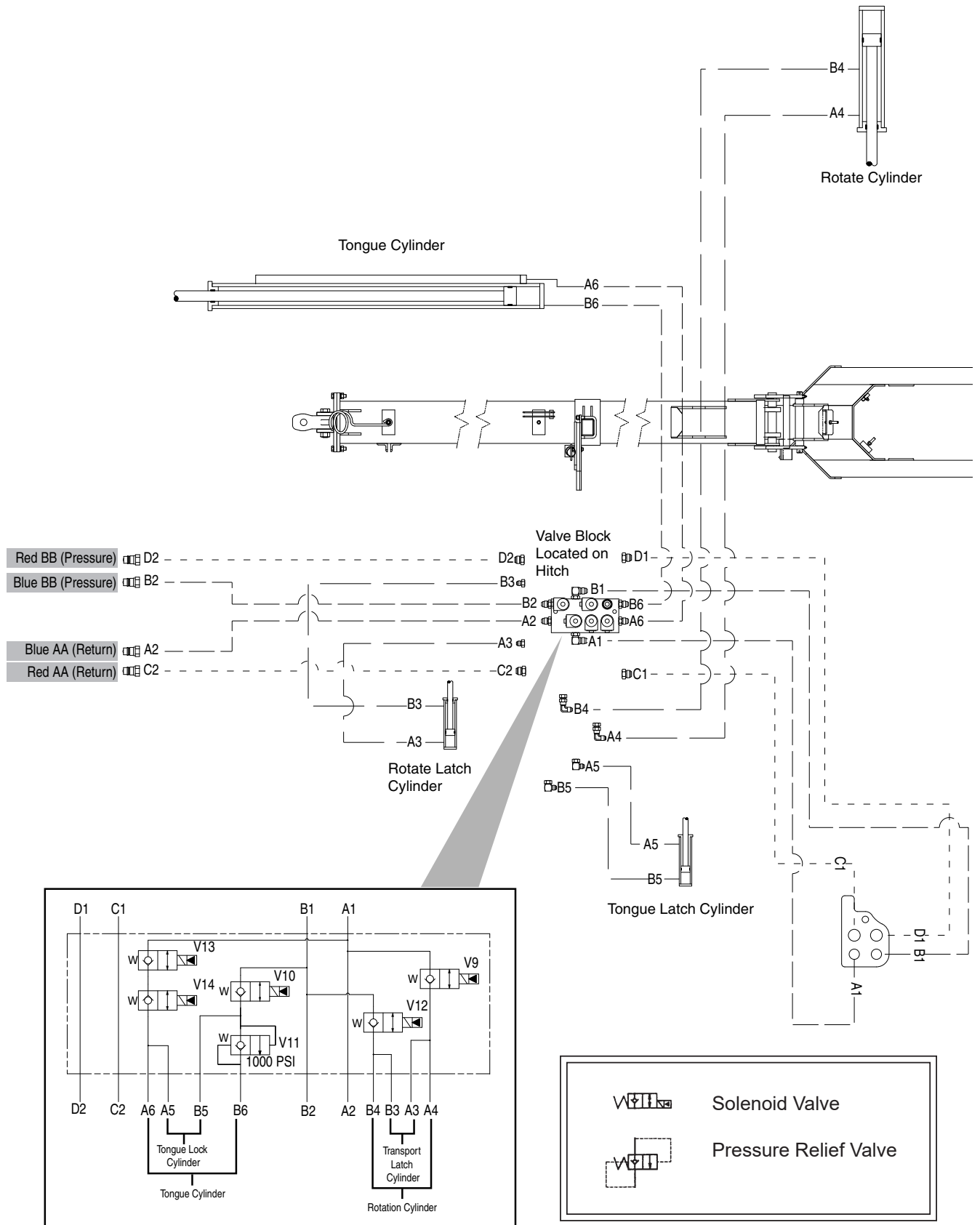

### Hydraulic System Schematic

12 Row (One Wing Lift Cylinder Per Wing) and 16 Row Shown (Two Wing Lift Cylinders Per Wing)

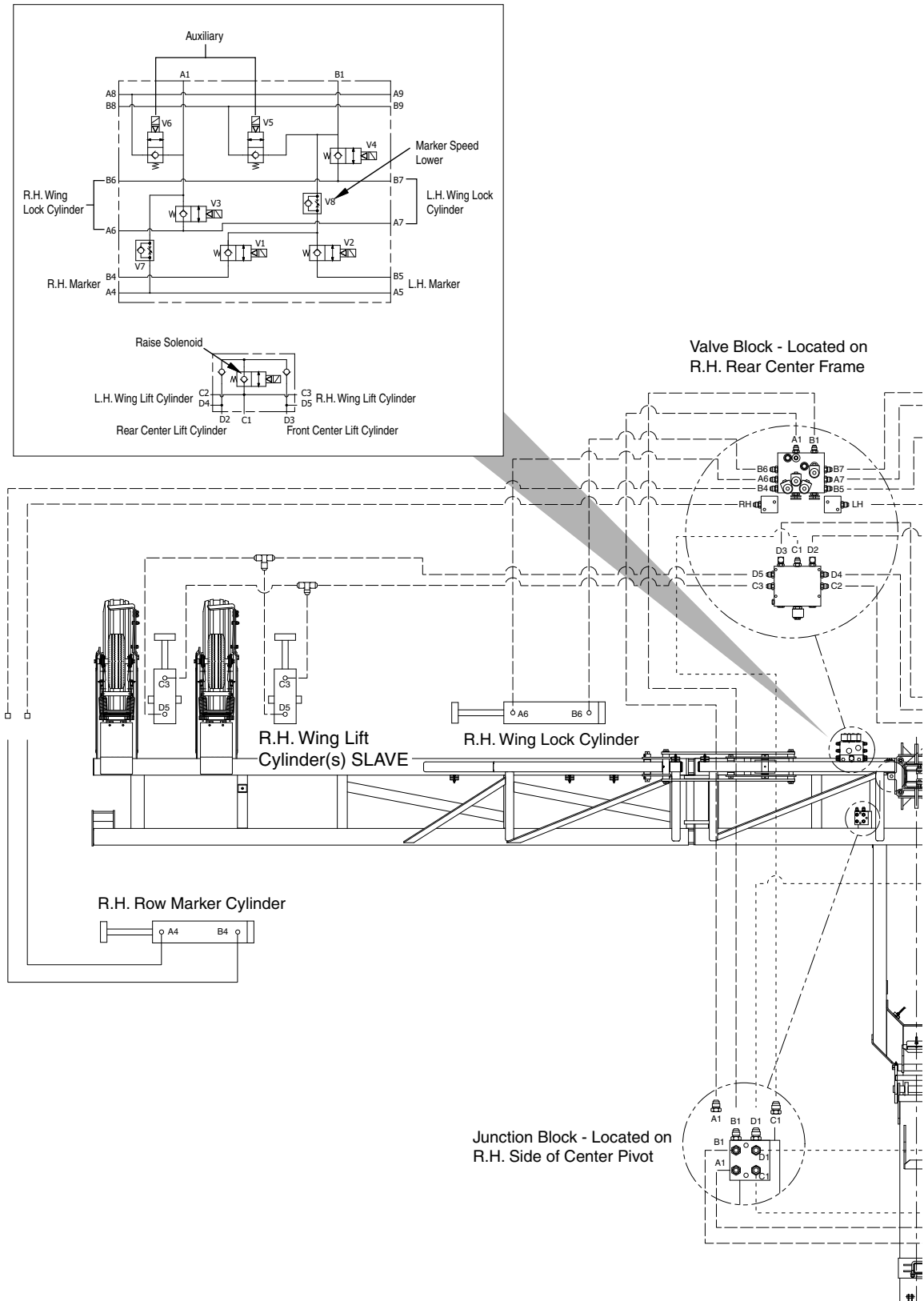

For Blue Drive Hydraulic Schematics see Parts Manual.

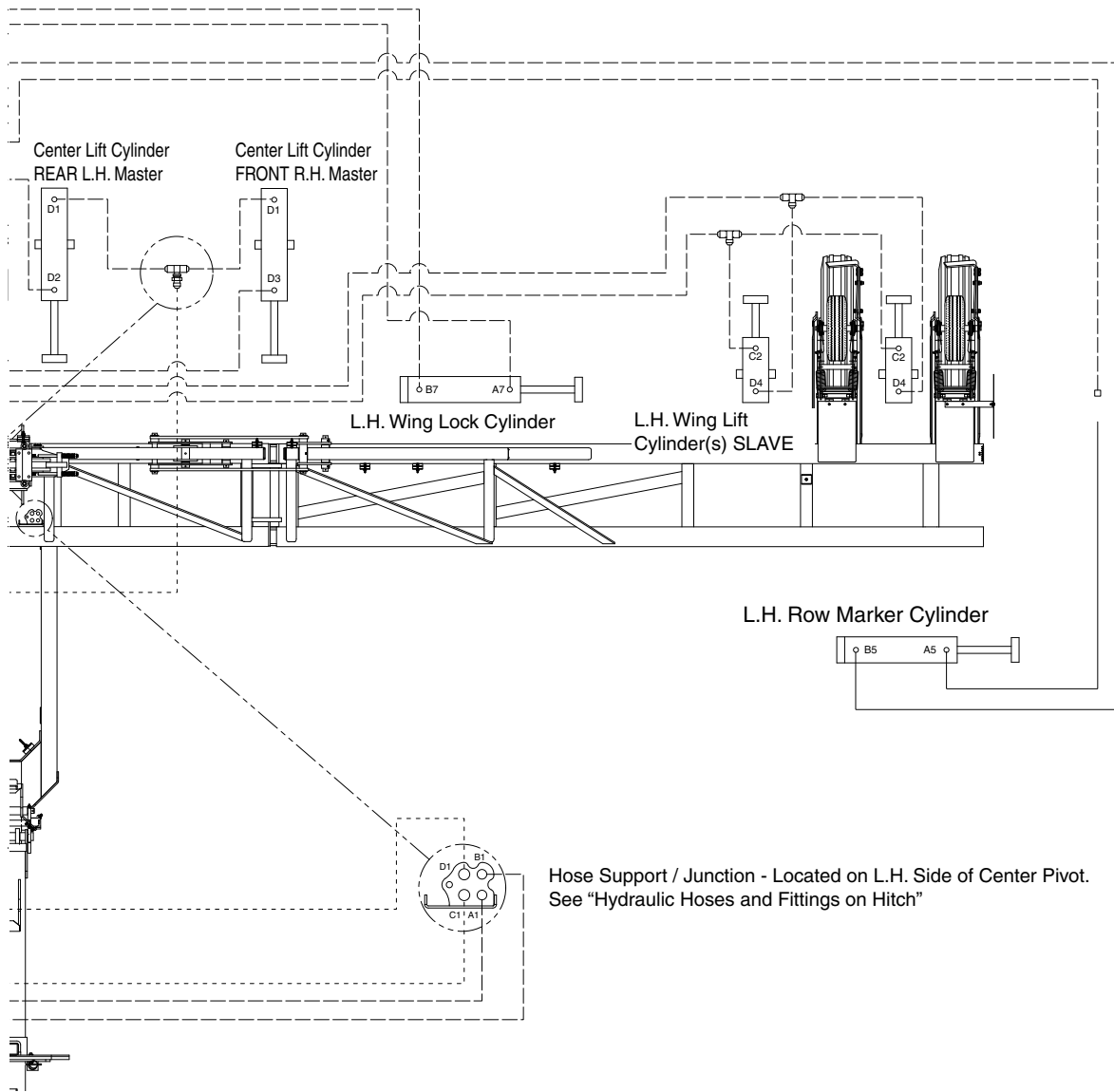
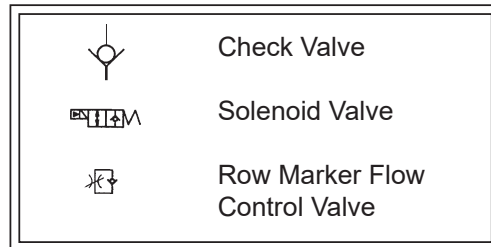

Hose Support / Junction - Located on L.H. Side of Center Pivot.  
See "Hydraulic Hoses and Fittings on Hitch"

HYDRAULIC SCHEMATIC - VACUUM FAN MOTOR SYSTEM

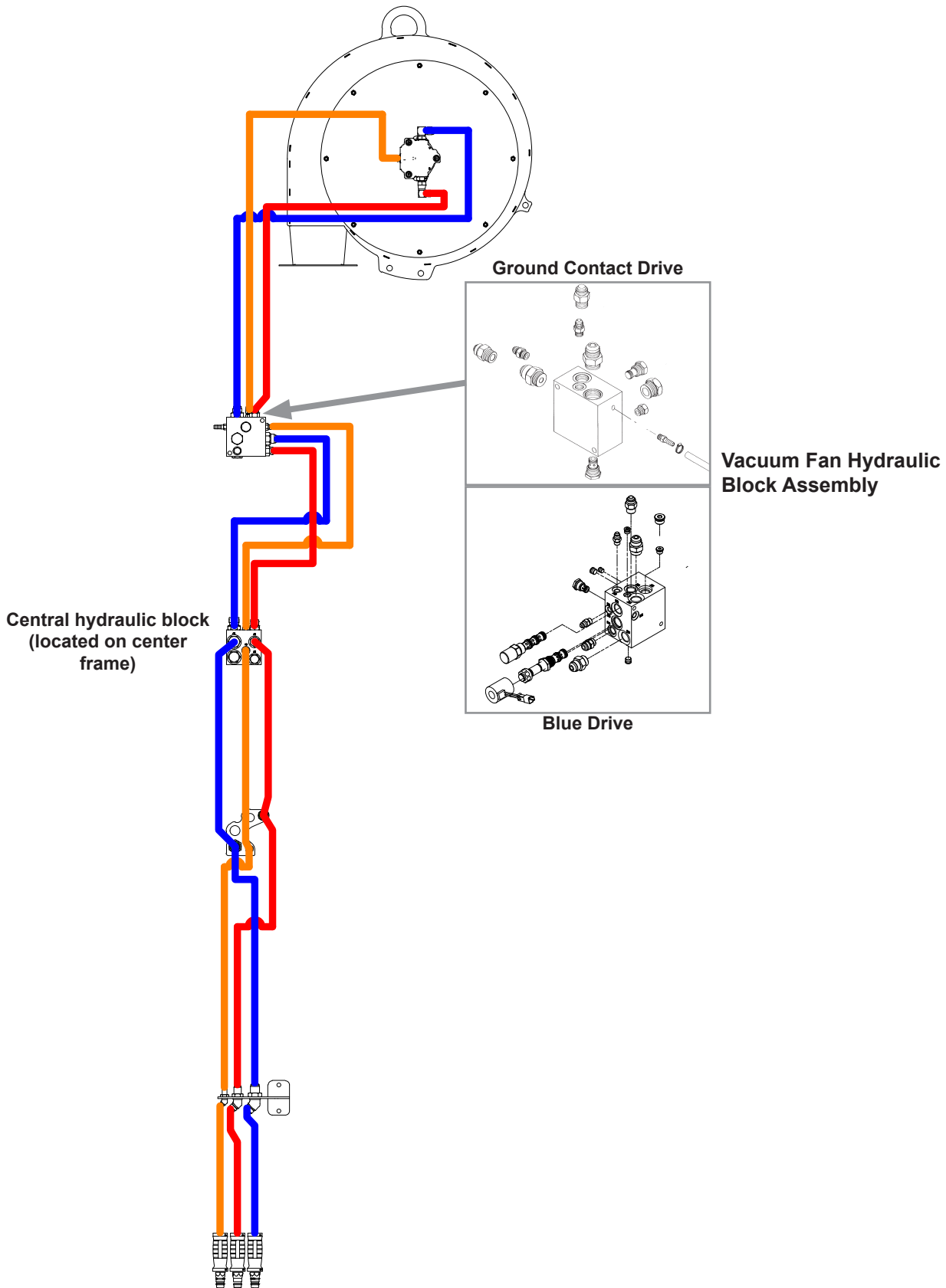

WING DOWN PRESSURE SCHEMATIC (WEIGHT TRANSFER MECHANISM)

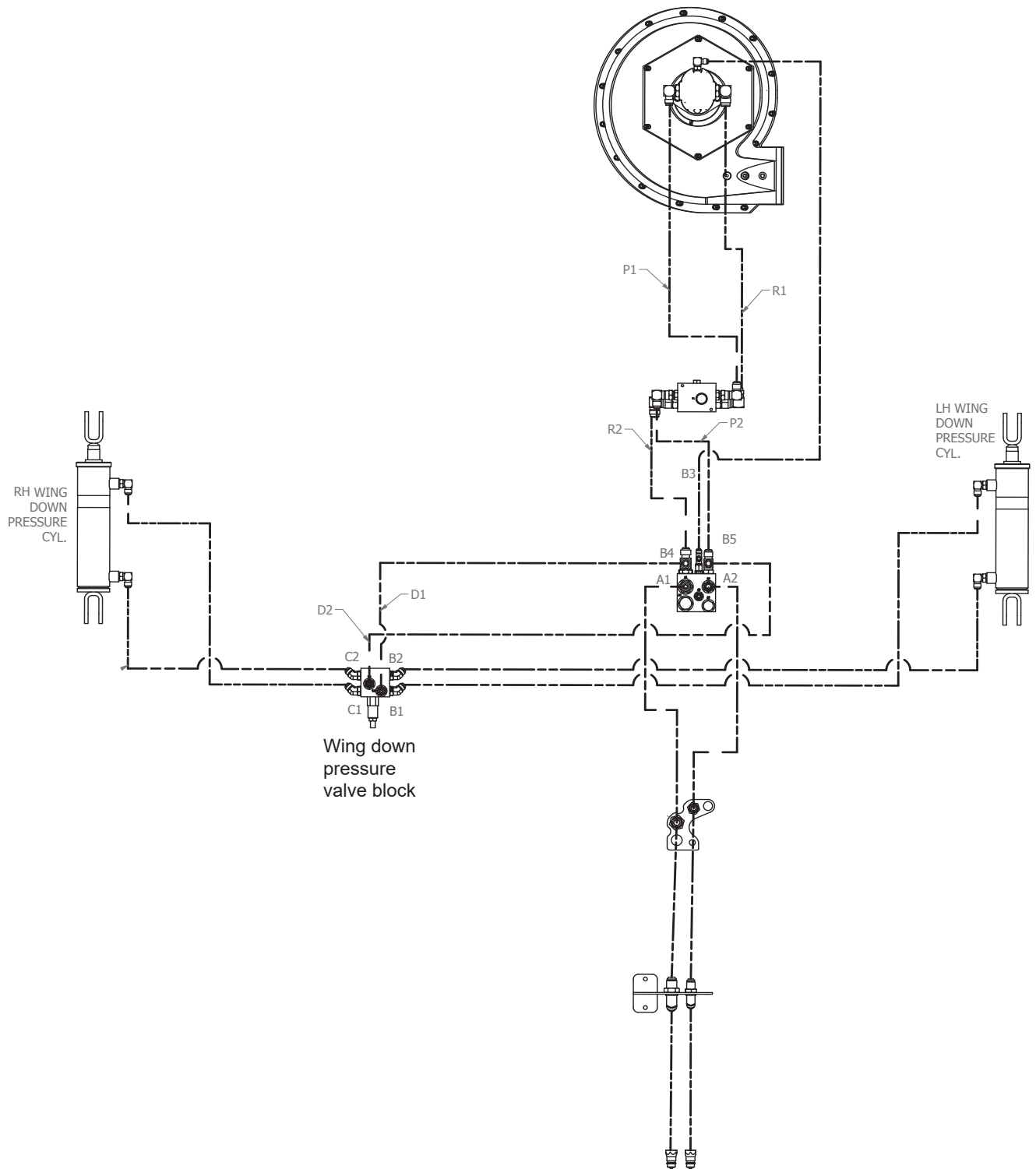

TRUE DEPTH HYDRAULIC SCHEMATIC, 16 ROW

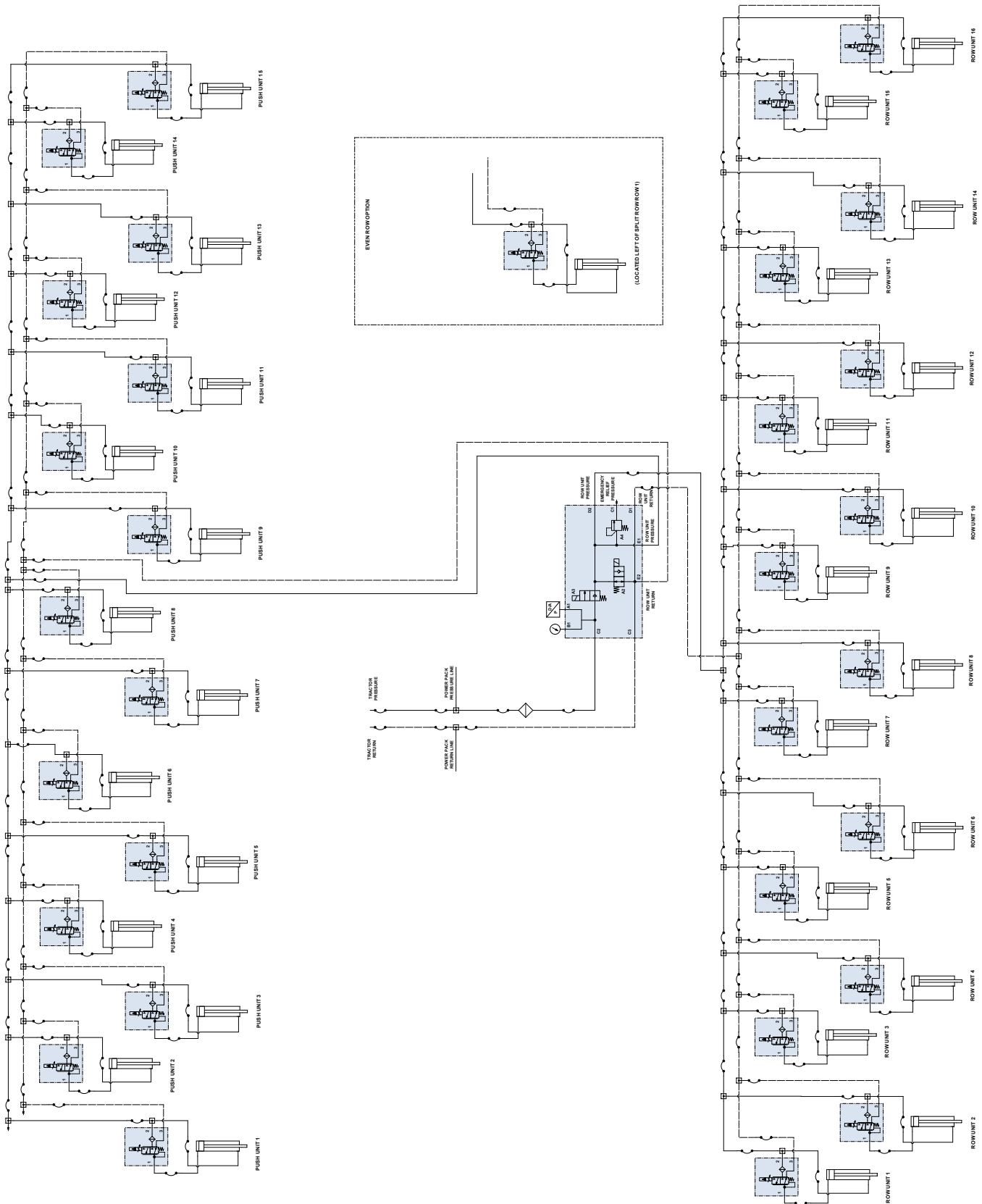



TRUE DEPTH HYDRAULIC SCHEMATIC, 12 ROW

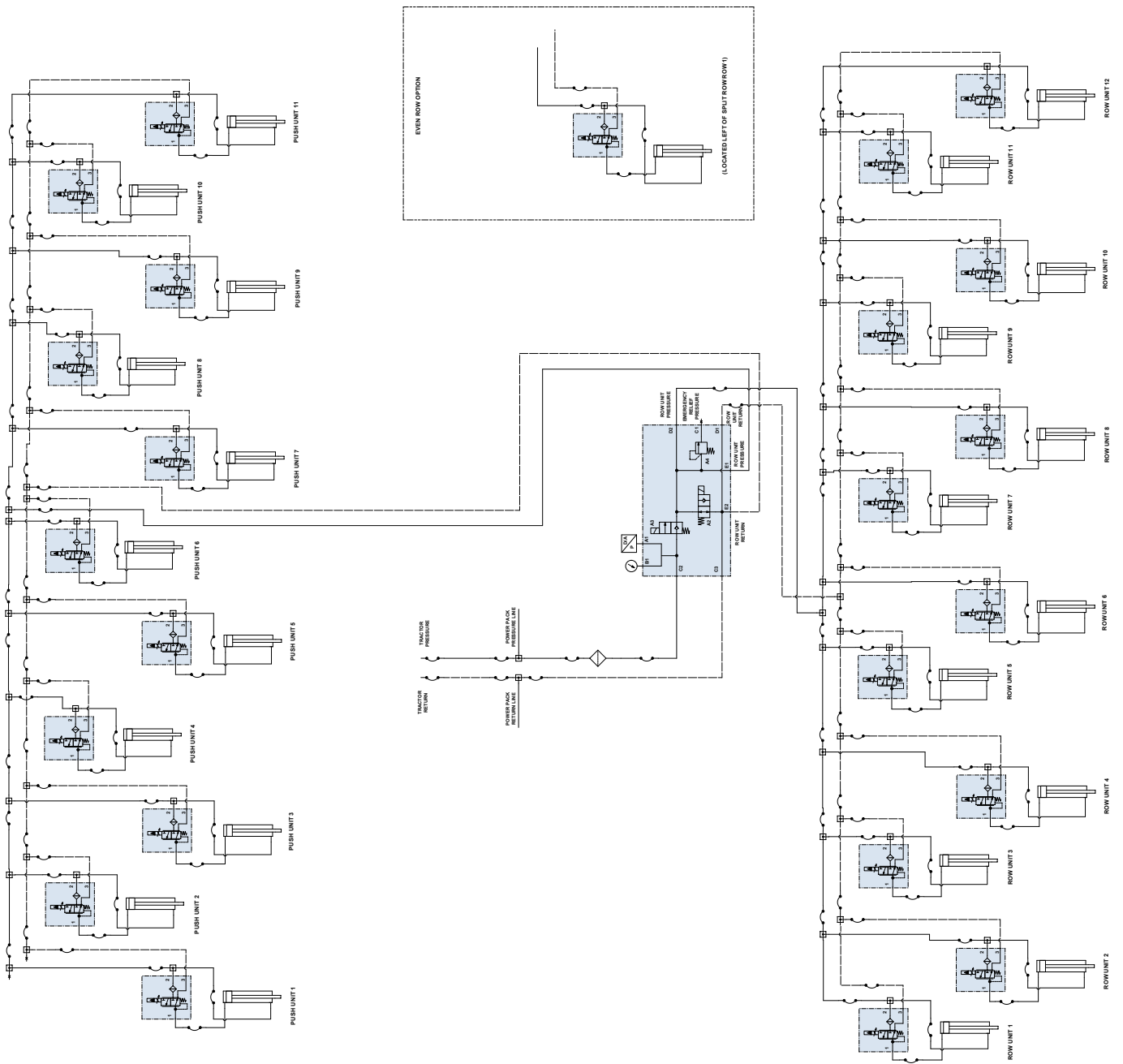

**POWER PACK WIRING DIAGRAM (BLUE DRIVE)**

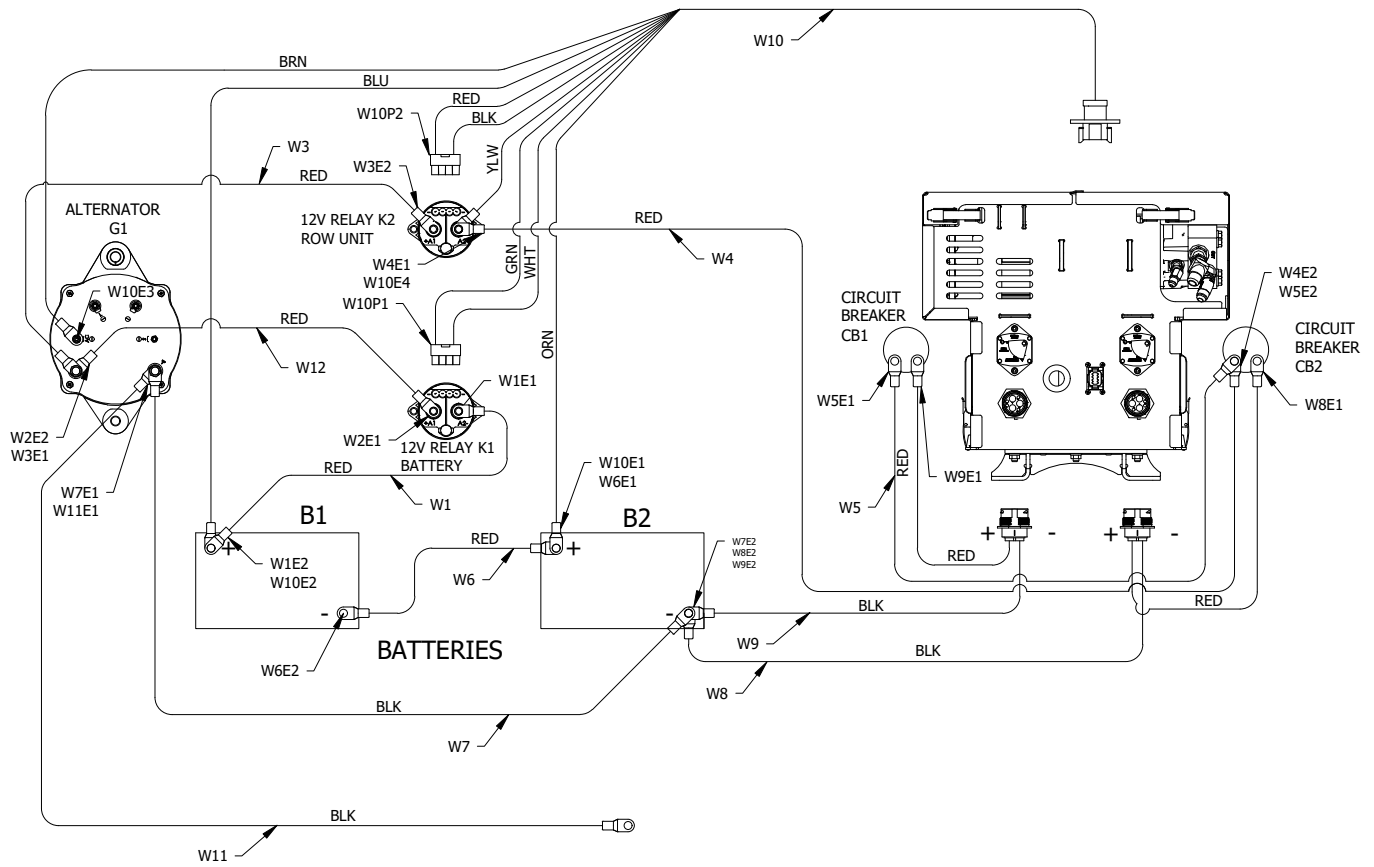

Component Hookup Chart, P/N 10112901

Reference Designator	From	Used with Item	To	Used with Item	Color	Function
W1	B1+	E2	K1A2-	E1	Red	Power
W12	K1A1+	E1	GB1+	E2	Red	Power
W3	GB1+	E1	K2A1+	E2	Red	Power
W4	K2A2-	E1	CB2, Line	E2	Red	Power
W5	CB1, Line	E1	CB2, Line	E2	Red	Power
W6	B2+	E1	B1-	E2	Red	Power
W7	B2-	E2	GB2-	E1	Black	Ground
W8	Pan	J1	CB2, Load	E1	Red	Power
			B2-	E2	Black	Ground
W9	Pan	J1	CB1, Load	E1	Red	Power
			B2-	E2	Black	Ground
W10	Pan	J1	K2	P2	Red/Black	RU Power Relay (Power & Ground)
			AC	E3	Brown	Alternator Sensor Frequency
			K2A2-	E4	Yellow	RU Power Feedback
			K1	P1	Green/White	Battery Pack Relay (Power & Ground)
			B1+	E2	Blue	Battery #1 Voltage Monitor
W11	GB2-	E1	NC	E2	Black	Planter Ground

## CABLES AND HARNESSES

This section includes information on planter cable and harness connections, make up and wiring for troubleshooting, maintenance and repair purposes.



**DANGER**

**Before attempting to repair electrical wiring, make sure the harness or cable in question is disconnected from the battery or any other power source. Failing to do so might lead to serious injury.**

Ethernet Cables

Color	From	To
White/Orange	P1-1	P2-1
White/Green	P1-2	P2-2
Orange	P1-3	P2-3
Green	P1-4	P2-4

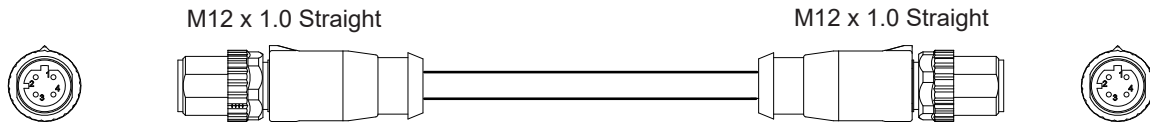

Ethernet Cable	
Part Number	Description
A22554-	Ethernet Ca CAT 5E (M12 STR-M12 STR)

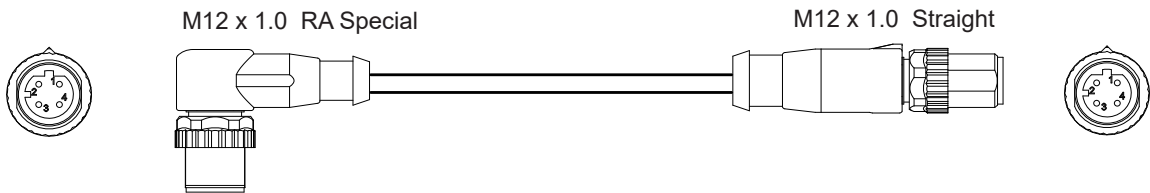

Ethernet Cable	
Part Number	Description
A22555-	Ethernet Ca CAT 5E (M12 RA-M12 STR)

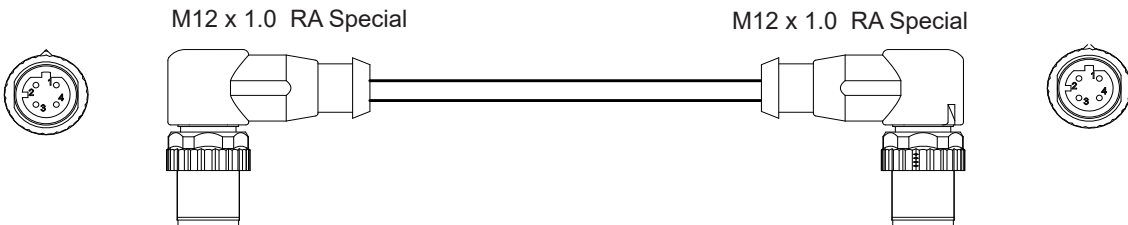

Ethernet Cable	
Part Number	Description
A22556-	Ethernet Ca CAT 5E (M12 RA-M12 RA)

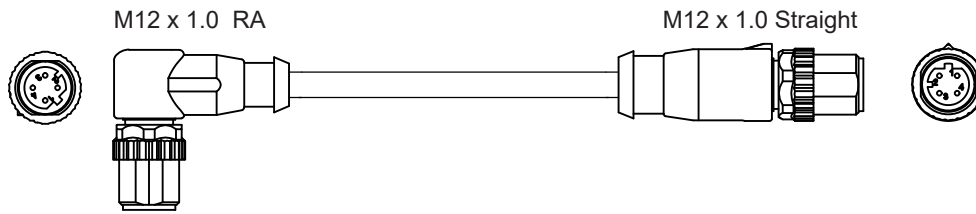

Ethernet Cable	
Part Number	Description
A24488-	Ethernet Ca CAT 5 (M12 RA-M12 STR)

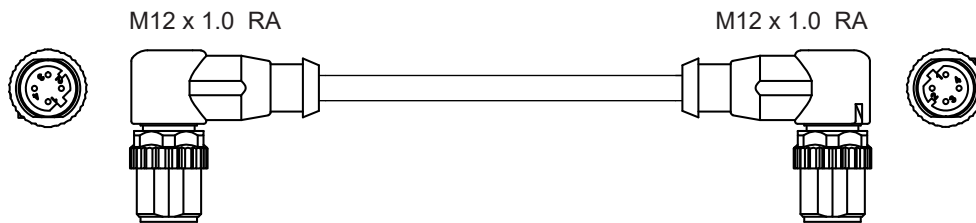

Ethernet Cable	
Part Number	Description
A24487-	Ethernet Ca CAT 5 (M12 RA-M12 RA)

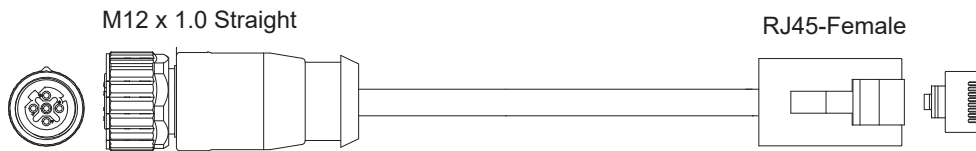

Ethernet Cable	
Part Number	Description
A25399-	Ethernet Ca CAT 5 (RJ45-Female-M12 STR)

**Harness Row Unit Power Extension**

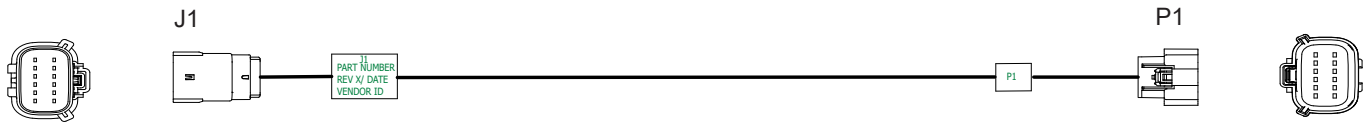

P/N A25029				
Signal	Wire Gauge	Color	FROM	TO
Power	16	Red	J1-1	P1-1
Ground	16	Black	J1-2	P1-2
Power	16	Red	J1-3	P1-3
Ground	16	Black	J1-4	P1-4
Strapping	20	Yellow	J1-5	P1-5
Strapping	20	Orange	J1-6	P1-6
Strapping	20	White	J1-7	P1-7
Strapping	20	Green	J1-8	P1-8
Strapping	20	Blue	J1-9	P1-9
Strapping	20	Violet	J1-10	P1-10
Strapping	20	Blue/Red	J1-11	P1-11
Strapping	20	Brown	J1-12	P1-12

**PDP Display Harness (Ground Contact Drive)**

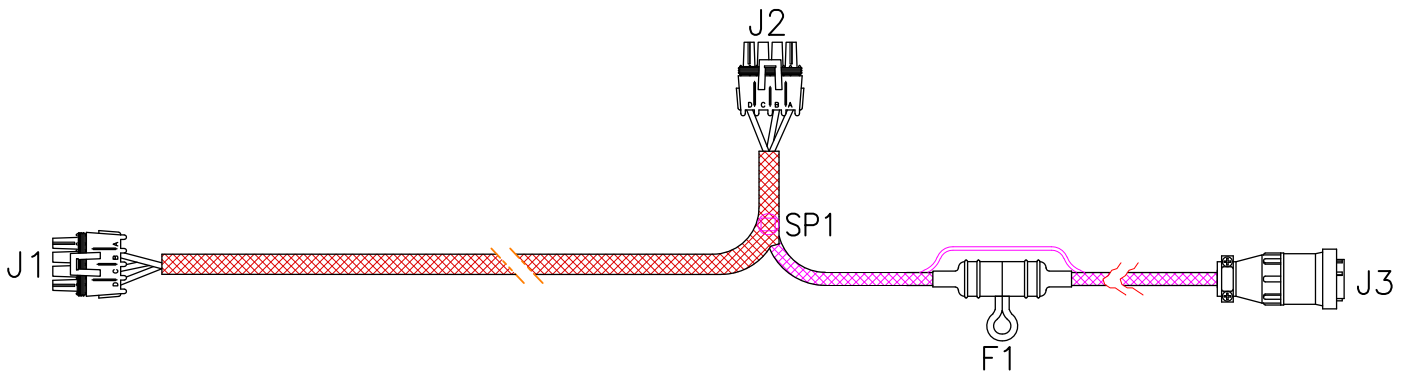

**Wire Hookup Chart, P/N A13944**

Reference Designator	From	To	Gauge	Color	Function
W1	11-A	12-A	16	Violet/White	Decrease
W2	11-B	SP1	16	Blue	Ground
W3	SP1	J3-3	16	Black	Ground
W4	11-C	12-C	16	Orange/White	Increase
W5	12-D	F1-1	16	Red	Power
W6	FI-2	13-1	16	Red	Power

**Worklights Relay Harness**

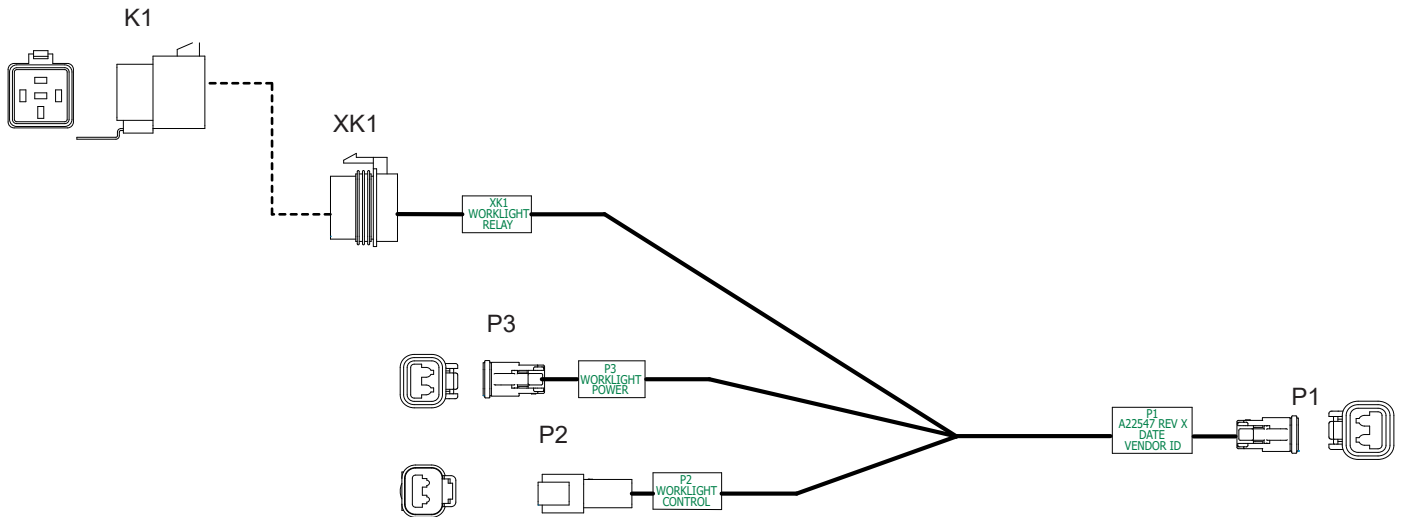

P/N A22547				
Signal	Wire Gauge	Color	From	To
Worklight Power -	16	Blue	P3-1	P1-1
Worklight Power +	16	Red	P3-2	XK1-30
Relay Ground	16	Black	P2-1	XK1-85
Relay 12V	16	Blue	P2-2	XK1-86
Worklight Power +	16	Red	XK1-87	P1-2

**Power Adapter Harness (Optional)**

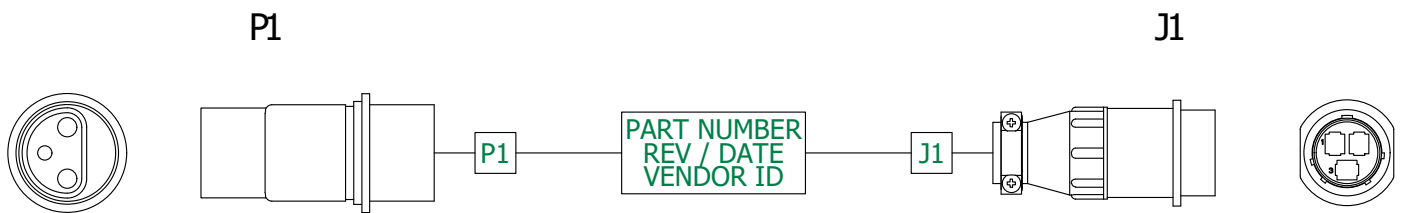

Wire Hookup Chart, P/N A26751

Reference Designator	From	To	Gauge	Color	Function
W1	P1-15/30	J1-1	14	Yellow/Red	Switched Power
W2	P1-82	J1-2	10	Red	Power
W3	P1-31	J1-3	10	Black	Ground

Wing IPP Harness

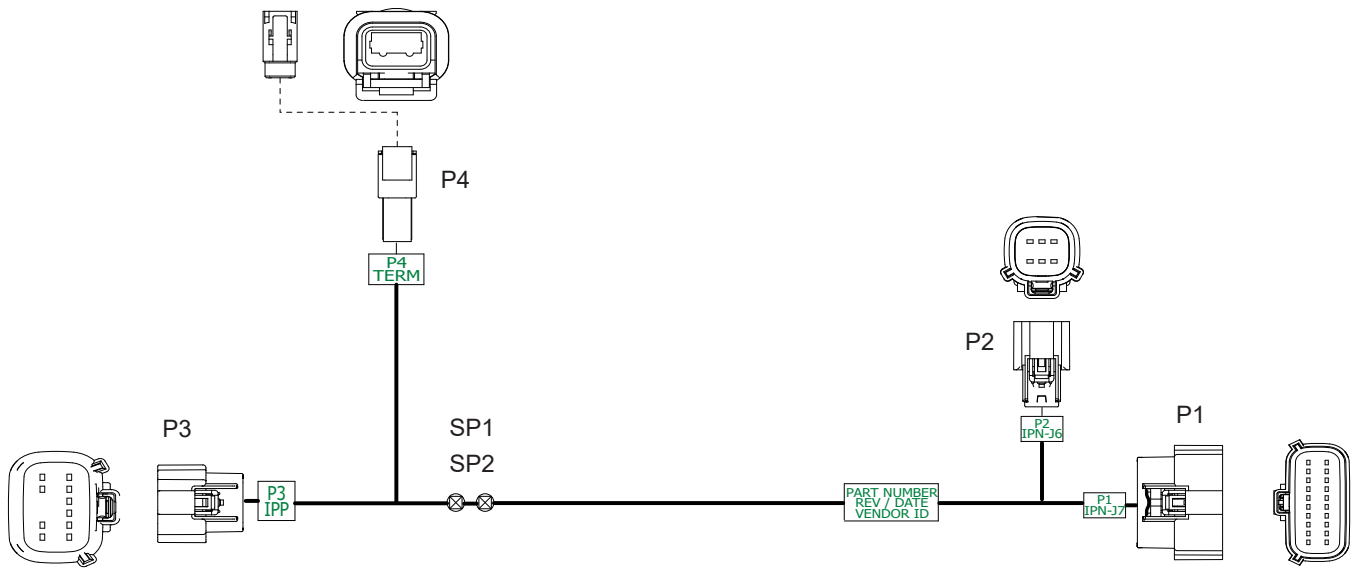

P/N A25214				
Signal	Wire Gauge	Color	From	To
RS232 RX	18(TP)	ORN	P1-1	P3-1
RS232 TX	18(TP)	BRN	P1-2	P3-2
CAN HI	18(TP)	YEL	P2-1	SP1
CAN LO	18(TP)	GRN	P2-2	SP2
Power	16	RED	P2-3	P3-12
Ground	16	BLK	P2-4	P3-6
IPP Software Update	18	BLU	P2-5	P3-11
CAN HI	18(TP)	YEL	SP1	P3-5
CAN LO	18(TP)	GRN	SP2	P3-4
CAN HI	18(TP)	YEL	SP1	P4-1
CAN LO	18(TP)	GRN	SP2	P4-2

Cable Power Adapter (Ground Contact Drive)

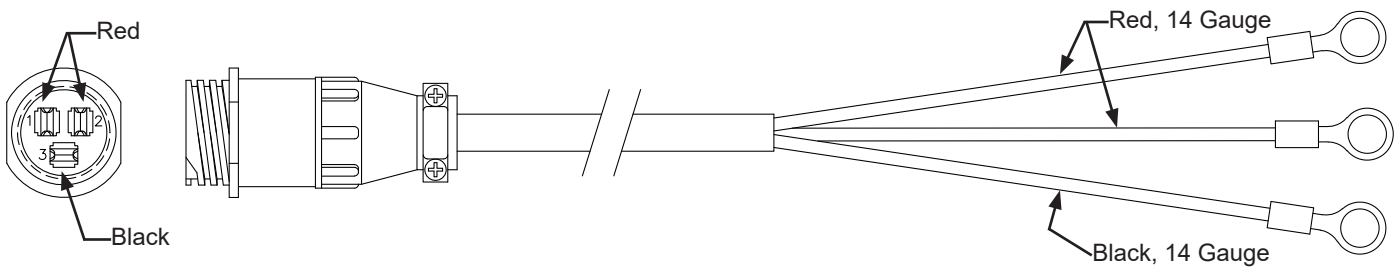



**RU Seed Meter Harness**

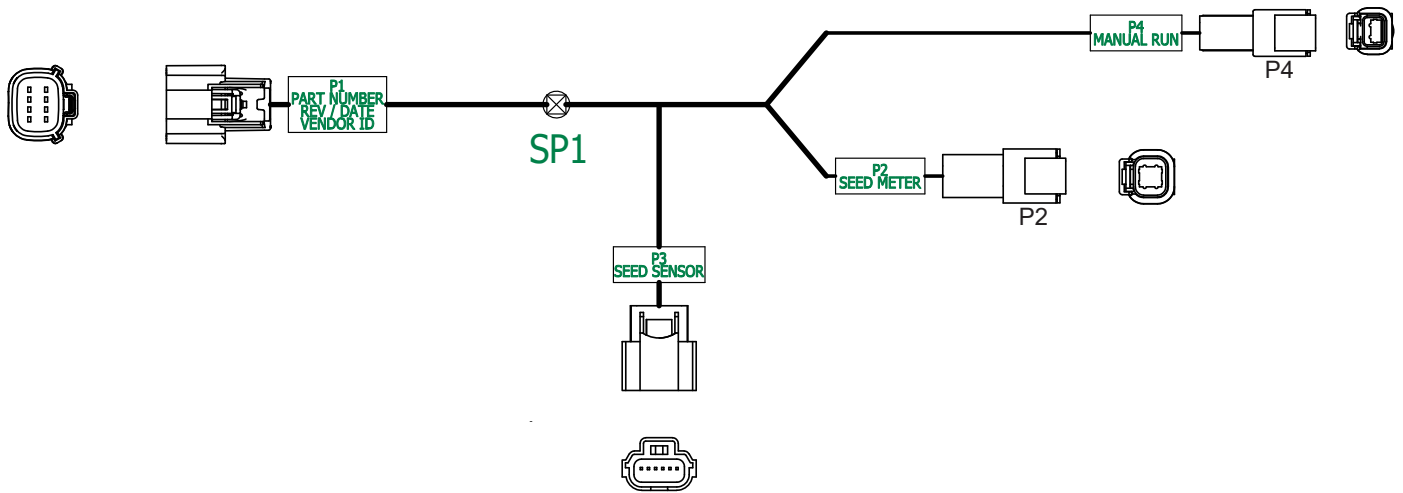

**Wire Hookup Chart, P/N A25038/A25039**

Reference Designator	From	To	Gauge	Color	Function
W1	P1-1	P2-1	18	Red	Seed Meter Motor #1, +
W2	P1-2	P2-2	18	White	Seed Meter Motor #1, -
W3	P1-3	P2-4	18	Black	Seed Meter Motor #2, -
W4	P1-4	P2-3	18	Green	Seed Meter Motor #2, +
W5	P1-5	P3-1	18	Red	Speed Sensor (Power)
W6	P1-6	SP1	18	Black	Ground
W7	P1-7	P3-2	18	Blue	Seed Sensor (Line)
W8	SP1	P3-6	18	Black	Seed Sensor (Ground)
W9		P4-1	18	Black	Manual Run (Ground)
W10	P1-8	P4-2	18	Red	Manual Run (Input)

**RU ESD Drain Harness**



**Worklight Harness (Ground Contact Drive)**

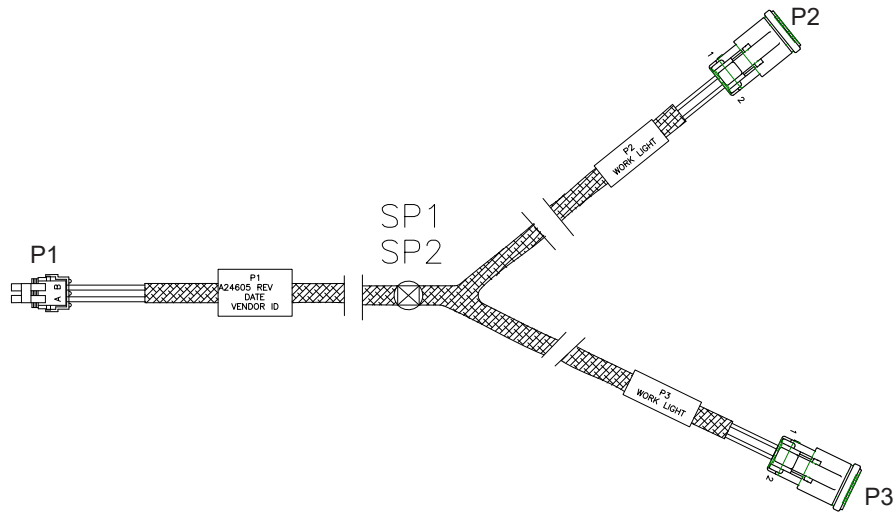

**Wire Hookup Chart, P/N A24605**

Reference Designator	From	To	Gauge	Color	Function
W1	P1-A	SP1	14	White	Ground
W2	P1-B	SP2	14	Black	Power
W3	SP1	P21	14	White	Ground
W4	SP1	P3-1	14	White	Ground
W5	SP2	P2-2	14	Black	Power
W6	SP2	P3-2	14	Black	Power

**Worklight Switch Harness (Ground Contact Drive)**

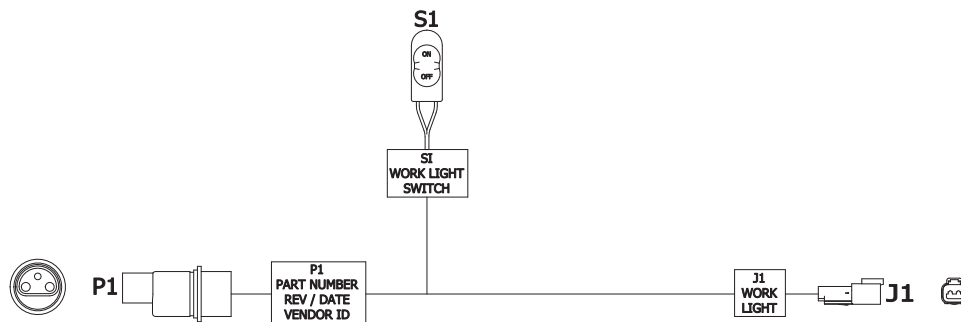

**Wire Hookup Chart, P/N A25785**

Reference Designator	From	To	Gauge	Color	Function
W1	P1-82	S1-1	14	Red	Tractor Power Switch
W3	P1-31	J1-2	14	White	Ground
W5	S1-2	J1-1	14	Black	Power Switch

**Worklight Switch Harness (Blue Drive Drive)**

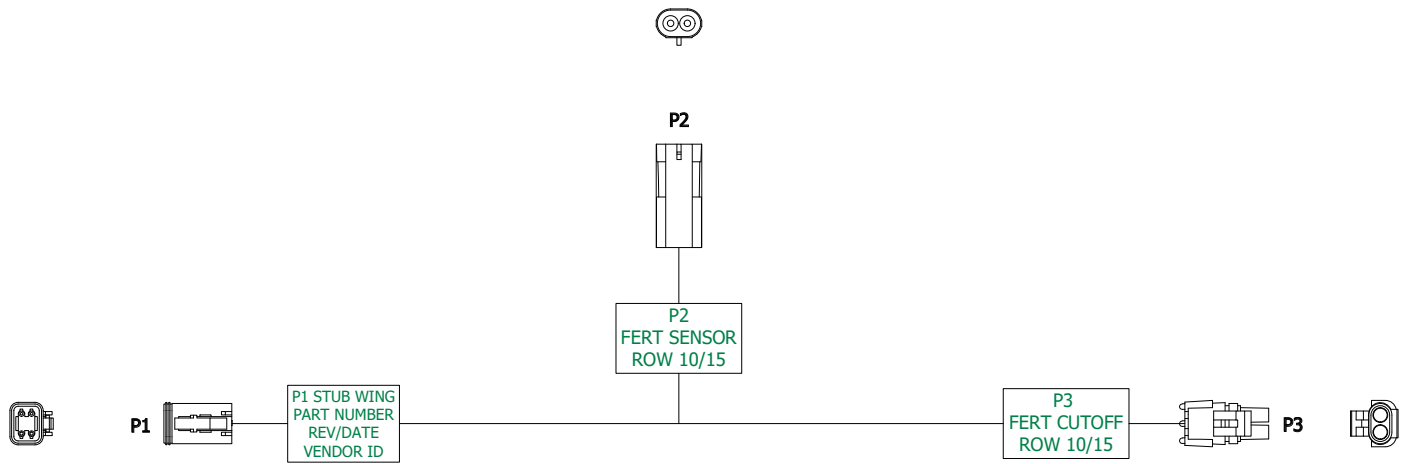

**Wire Hookup Chart, P/N A25714**

Reference Designator	From	To	Gauge	Color	Function
W1	P1-1	P3-A	18	Red	Fertilizer Row Cutoff Valve (Power)
W2	P1-2	P3-B	18	Black	Fertilizer Row Cutoff Valve (Ground)
W3	P1-3	P2-A	18	Red	Fertilizer Flow Sensor (Power Signal)

**Compressor Harness**

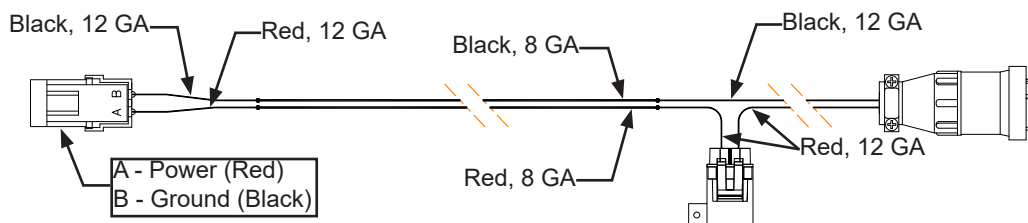

Integrated True Depth RU Harness

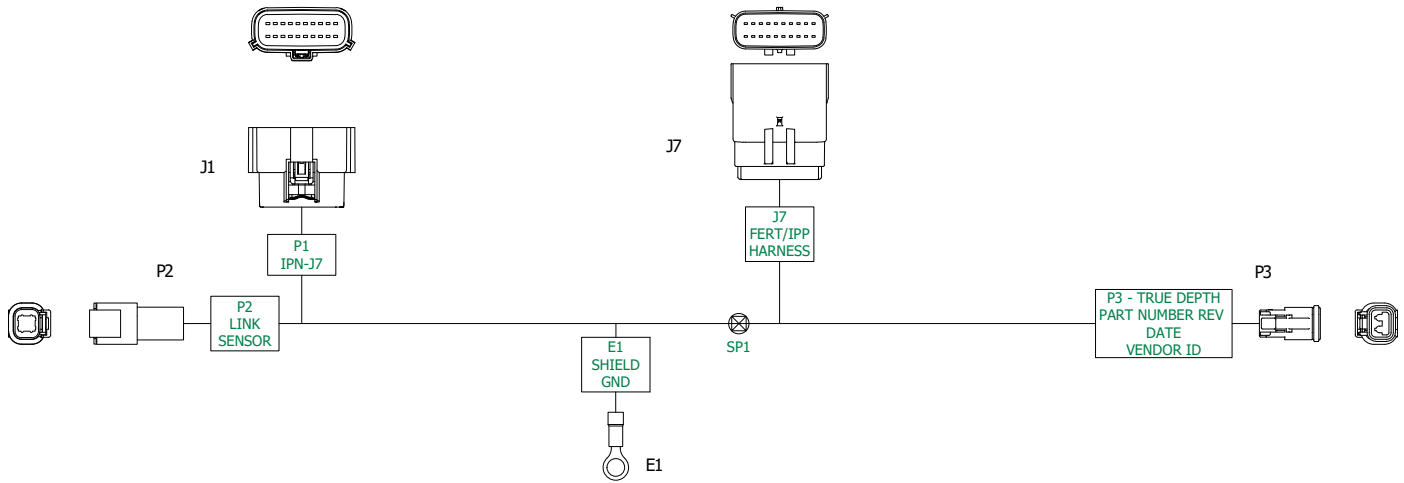

Wire Hookup Chart, P/N A26709

Reference Designator	From	To	Gauge	Color	Function
W1	P1-1	J7-1	18	Orange	RS232 RX
W2	P1-2	J7-2	18	Brown	RS232 TX
W3	P1-3	J7-3	18	Red	Fertilizer Flow Cutoff Valve (Power)
W4	P1-4	J7-4	18	Black	Fertilizer Flow Cutoff Valve (Ground)
W5	P1-7	P3-1	18	Red	True Depth Cylinder PWM+
W6	P1-8	P3-2	18	Black	True Depth Cylinder PWM-
W7	P1-13	J7-13	18	Red	Fertilizer Flow Sensor (Power/Signal)
W8	P1-16	P2-2	18	Black	True Depth Link Sensor (Signal)
W9	P1-19	SP1	18	Black	Sensor (Ground)
W10	SP1	J7-19	18	-	Fertilizer Flow Sensor (Ground)
W11	SP1	P2-4	18	Black	True Depth Link Sensor (Ground)
W12	P1-20	P2-1	18	Red	True Depth Link Sensor (Power)
W13	E1	P2-3	18	Green	True Depth Link Sensor (Shield)

4K RU Seed Meter Harness

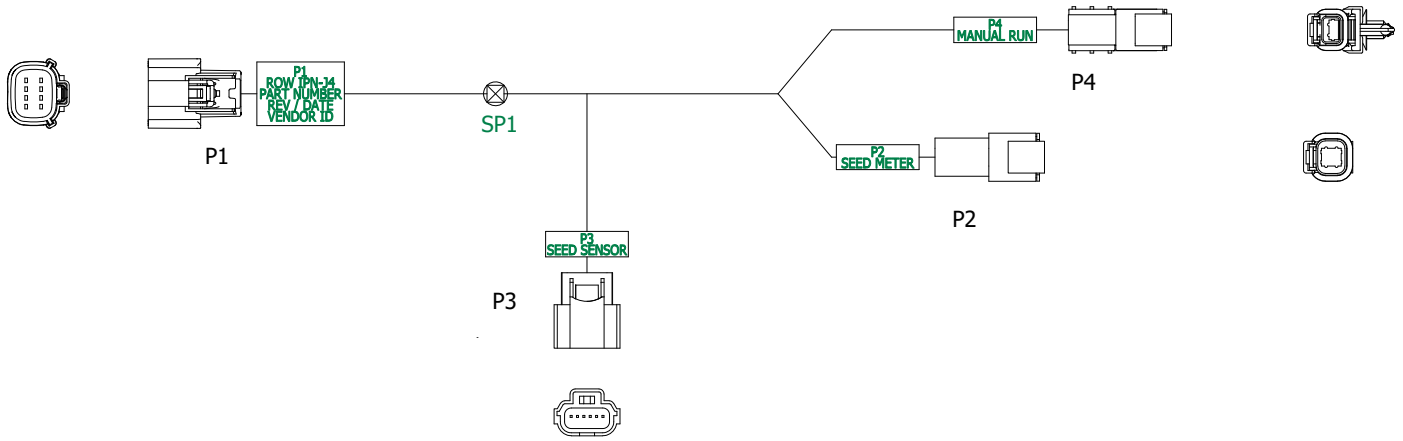

Wire Hookup Chart, P/N A25203

Reference Designator	From	To	Gauge	Color	Function
W1	P1-1	P2-1	18	Red	Seed Meter Motor #1, +
W2	P1-2	P2-2	18	White	Seed Meter Motor #1, -
W3	P1-3	P2-4	18	Black	Seed Meter Motor #2, -
W4	P1-4	P2-3	18	Green	Seed Meter Motor #2, +
W5	P1-5	P3-1	18	Red	Speed Sensor (Power)
W6	P1-6	SP1	18	Black	Ground
W7	P1-7	P3-2	18	Blue	Seed Sensor (Line)
W8	SP1	P3-6	18	Black	Seed Sensor (Ground)
W9		P4-1	18	Black	Manual Run (Ground)
W10	P1-8	P4-2	18	Red	Manual Run (Input)

Seed Meter Motor ESD Drain Harness

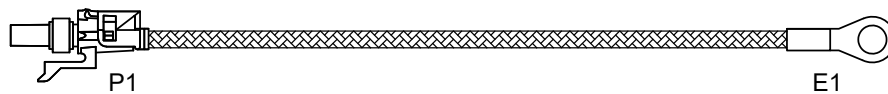

Tail Light Harness

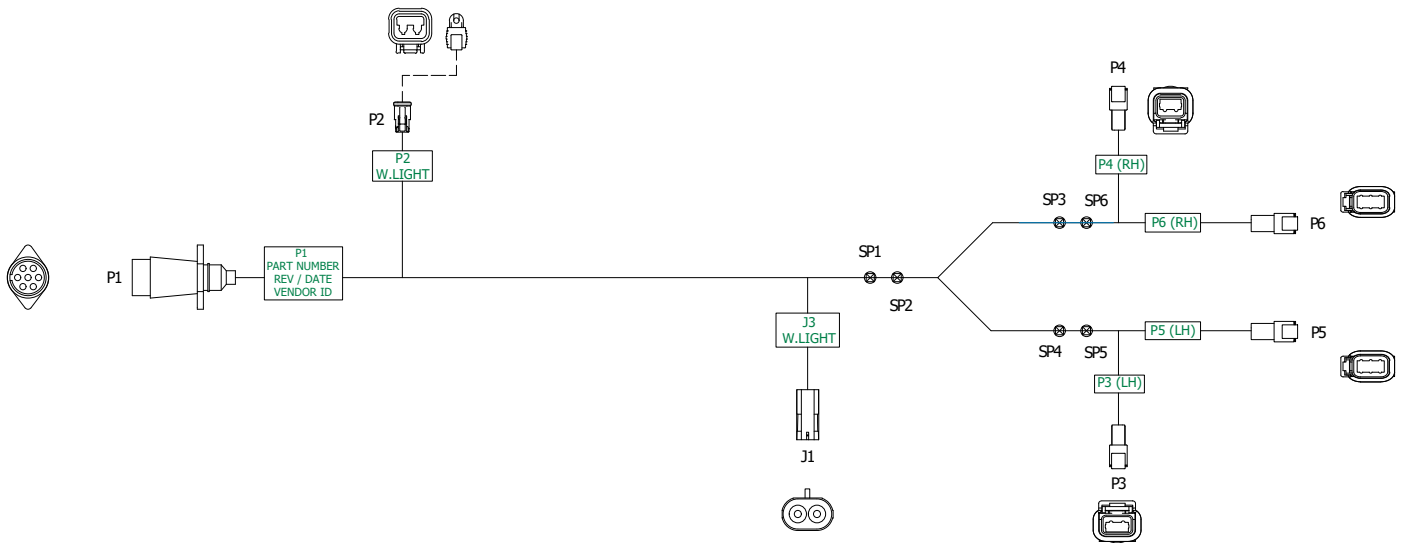

Wire Hookup Chart, P/N 10174301

Reference Designator	From	To	Gauge	Color	Function
W1	P2-1	J3-B	14	White	Worklight 12V+
W2	P2-2	J3-A	14	Black	Worklight Ground
W3	P1-1	P5-4	16	Yellow	L.H. Flash
W4	P1-4	P6-4	16	Green	R.H. Flash
W5	P1-2	P5-5	16	Blue	Fog
W6	P1-3	SP1	16	White	Ground
W7	P1-6	SP2	16	Red	Stop Lights
W8	P1-5	SP3	16	Brown	R.H. Tail Light Power
W9	P1-7	SP4	16	Black	L.H. Tail Light Power
W10	SP1	SP5	16	White	Ground (L.H.)
W11	SP1	SP6	16	White	Ground (R.H.)
W12	SP2	P5-2	16	Red	Stop Lights (L.H.)
W13	SP2	P6-2	16	Red	Stop Lights (R.H.)
W14	SP3	P4-2	16	Brown	R.H. White Tail Light (Power)
W15	SP3	P6-3	16	Brown	R.H. Tail Light (Power)
W16	SP4	P3-2	16	Black	L. White Tail Light (Power)
W17	SP4	P5-3	16	Black	L.H. Tail Light (Power)
W18	SP5	P3-1	16	White	L.H. White Tail Light (Ground)
W19	SP5	P5-6	16	White	L.H. Tail Light (Ground)
W20	SP6	P4-1	16	White	R.H. White Tail Light (Ground)
W21	SP6	P6-6	16	White	R.H. Tail Light (Ground)

**Tractor Power Harness Extension, 10"/16"**



**Wire Hookup Chart, P/N 10060901 (10") / 10060902 (16")**

Reference Designator	From	To	Gauge	Color	Function
W1	P1-3	SP1	6	Red	12V Power
W2	SP1	SP3	4	Red	12V Power
W3	SP3	P2-3	6	Red	12V Power
W4	P1-4	SP2	6	Black	12V Ground
W5	SP2	SP4	4	Black	12V Ground
W6	SP4	P2-4	6	Black	12V Ground

**3605 BDBV Raise Harness Adapter**

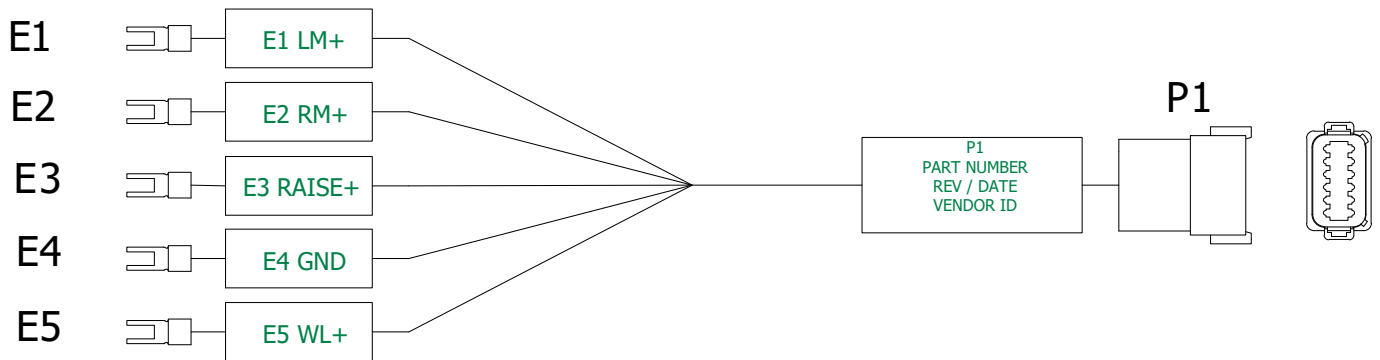

**Wire Hookup Chart, P/N 10172501**

Reference Designator	From	To	Gauge	Color	Function
W1	P1-1	E1	14	Blue	L.H. Marker Solenoid (+)
W2	P1-2	E2	14	Red	R.H. Marker Solenoid (+)
W3	P1-3	E3	14	Blue/Black	Raise Solenoid (+)
W4	P1-4	E4	14	Black	Ground
W5	P1-5	E5	14	Yellow/Red	Wing Lock Solenoid (+)

Tractor Power Harness

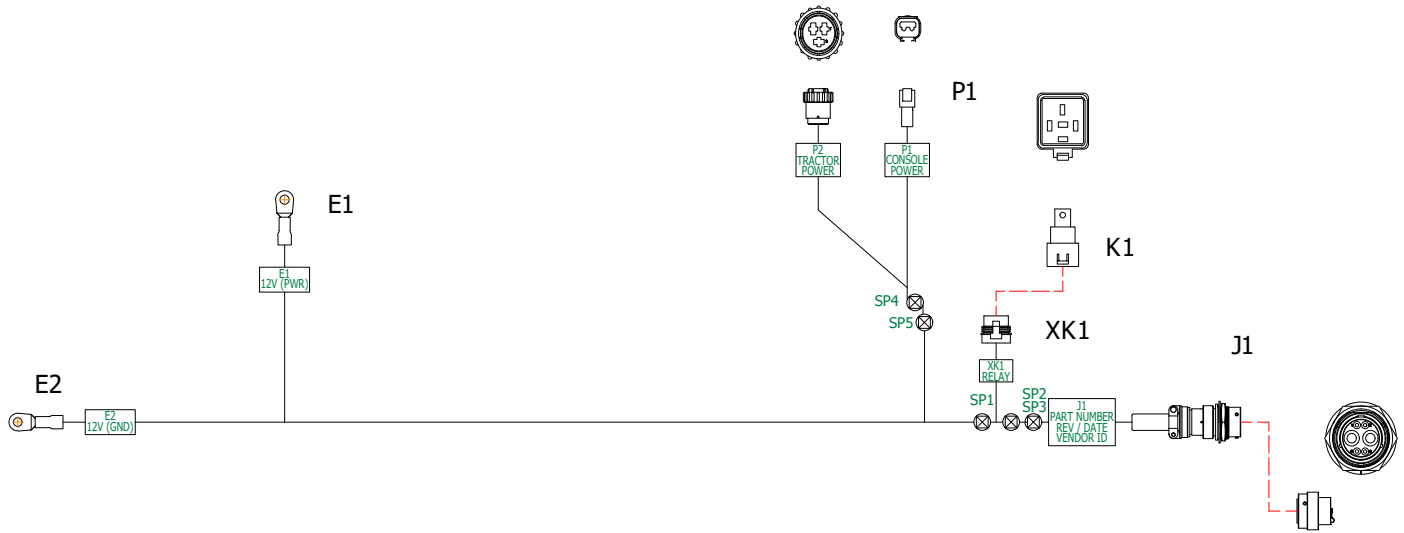

Wire Hookup Chart, P/N 10132601

Reference Designator	From	To	Gauge	Color	Function
W1	E1	SP1	2	Red	12V Power
W2	SP1	XK1-30	12	Red	12V Power
W3	XK1-87	SP2	12	Red	12V Power
W4	SP2	J1-3	4	Red	12V Power
W5	E2	SP3	2	Black	12V Ground
W6	SP3	J1-4	4	Black	12V Ground
W7	XK1-86	SP4	16	Blue	Switched Power (Coil)
W8	SP4	P2-1	16	Blue	Switched Power (Tractor)
W9	SP4	P1-1	18	Blue	Switched Power (Console)
W10	XK1-85	SP5	16	Black	Switched Ground (Coil)
W11	SP5	P2-3	16	Black	Switched Ground (Tractor)
W12	SP5	P1-2	18	Black	Switched Ground (Console)

Tractor Console Harness



Wire Hookup Chart, P/N 10132701

Reference Designator	From	To	Gauge	Color	Function
W6	P1-1	XF1-1	18	Red	12V Switched (Power)
W6	XF1-2	P3-1	18	Red	12V Switched (Power)
W10	P1-2	P3-2	18	Black	12V Switched (Ground)



3605 Rotation Plug-In Harness

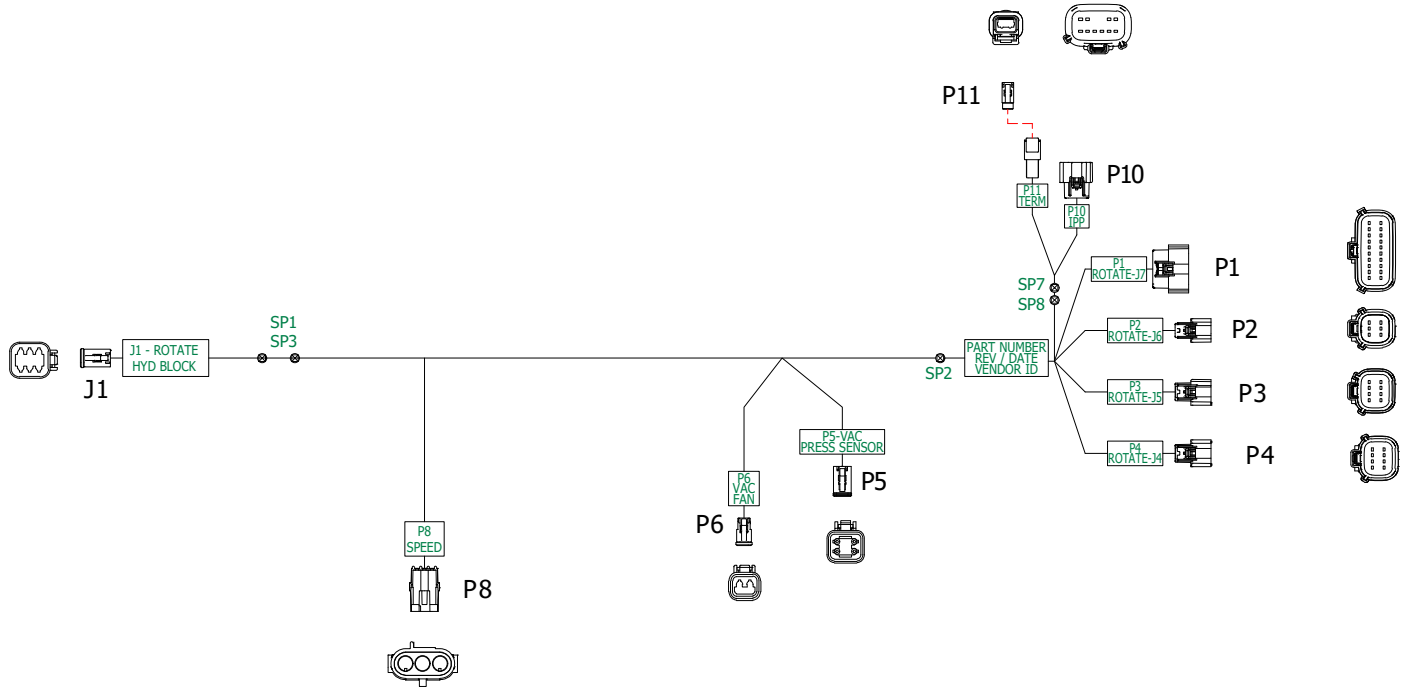

Wire Hookup Chart, P/N 10166701

Reference Designator	From	To	Gauge	Color	Function
W1	P1-1	P10-1	18	Orange	IPP RS232 RX
W2	P1-2	P10-2	-	Brown	IPP RS232 TX
W3	P1-3	P6-1	16	Red	Vacuum Solenoid (+)
W4	P1-4	P6-2	16	Black	Vacuum Solenoid (-)
W5	P1-7	SP1	14	Orange/Red	Tongue Solenoid (+)
W6	P1-8	SP2	14	Black/Red	Tongue Solenoid (-)
W7	P1-14	P5-4	18	Yellow	Vacuum Pressure Sensor (Signal)
W8	P2-1	SP7	18	Yellow	IPP CAN HI
W9	P2-2	SP8		Green	IPP CAN LO
W10	P2-3	P10-12	16	Red	IPP Power (+)
W11	P2-4	P10-6	16	Black	IPP Power (-)
W12	P2-5	P10-11	18	Blue	IPP Boot
W13	P3-5	P5-2	18	White	Vacuum Pressure Sensor (Power)
W14	P3-6	P5-1	18	Black	Vacuum Pressure Sensor (Ground)
W15	P3-7	P8-C	18	White	Wheel Speed (Frequency)
W16	P4-1	SP3	14	Blue/Red	Rotation Solenoid (+)
W17	P4-2	SP2	14	Black/Red	Rotation Solenoid (-)
W18	SP1	J1-4	14	Orange/Red	Tongue Solenoid (+)
W19	SP1	J1-5	14	Orange/Red	Tongue Solenoid (+)
W20	SP1	J1-6	14	Orange/Red	Tongue Solenoid (+)
W21	SP2	J1-1	14	Black/Red	Terminal Block (Ground)
W22	SP3	J1-2	14	Blue/Red	Rotation Solenoid (+)
W23	SP3	J1-3	14	Blue/Red	Rotation Solenoid (+)
W24	P4-6	P8-B	18	Black	Wheel Speed (Ground)
W25	P4-5	P8-A	18	Red	Wheel Speed (Power)
W26	SP7	P10-5	18	Yellow	IPP CAN HI
W27	SP8	P10-4	-	Green	IPP CAN LO
W28	SP7	P11-1	18	Yellow	CAN HI Terminator
W29	SP8	P11-2	-	Green	CAN LO Terminator

3605 Raise Plug-In Harness

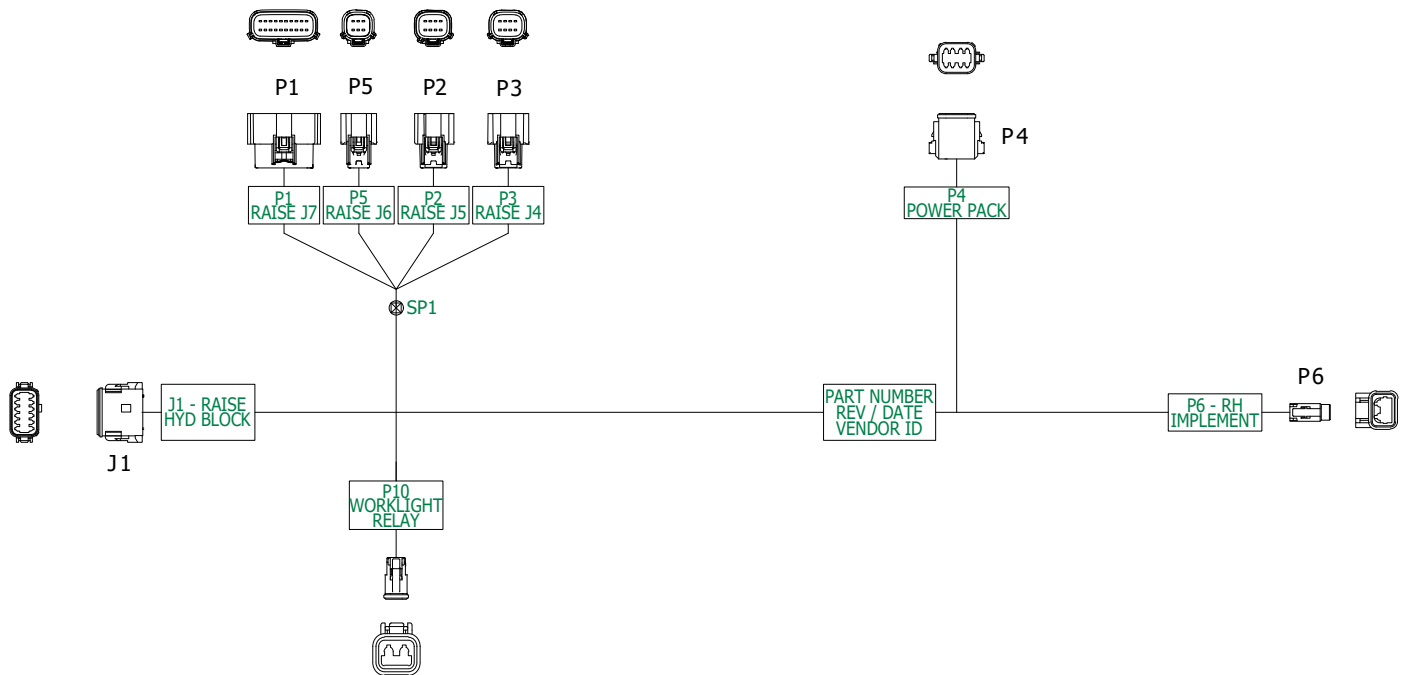

Wire Hookup Chart, P/N 10166801

Reference Designator	From	To	Gauge	Color	Function
W1	P1-3	J1-5	16	Yellow/Red	Wing Lock Solenoid (+)
W2	P1-4	SP1	16	Black	Wing Lock Solenoid (-)
W3	P1-7	J1-1	16	Blue	L.H. Marker Solenoid (+)
W4	P1-8	SP1	16	Black	L.H. Marker Solenoid (-)
W5	P1-13	P4-4	20	Yellow	RU Power Feedback
W6	P1-14	P4-7	14	Orange	Battery #1 Voltage
W7	P1-16	P4-8	14	Blue	Battery #2 Voltage
W8	P1-17	P4-2	16	Black	RU Power Relay (Ground)
W9	P1-18	P4-1	16	Red	RU Power Relay (Power)
W10	P1-19	P10-1	16	Black	Worklight Relay (-)
W11	P1-20	P10-2	16	Red	Worklight Relay (+)
W12	P2-1	J1-2	16	Red	R.H. Marker Solenoid (+)
W13	P2-2	SP1	16	Black	R.H. Marker Solenoid (-)
W14	P2-5	P6-1	18	Brown	R.H. Implement Switch (Power)
W15	P2-7	P6-2	18	Green	R.H. Implement Switch (Signal)
W16	P3-1	J1-3	16	Blue/Black	Raise Solenoid (+)
W17	P3-2	SP1	16	Black	Raise Solenoid (-)
W18	P3-8	P4-3	16	Brown	Alternator Sensor (Frequency)
W19	SP1	J1-4	16	Black	Terminal Block (Ground)
W20	P5-5	P4-5	16	White	Battery Pack Relay (Power)
W21	P5-6	P4-6	16	Green	Battery Pack Relay (Ground)

12V Power Harness

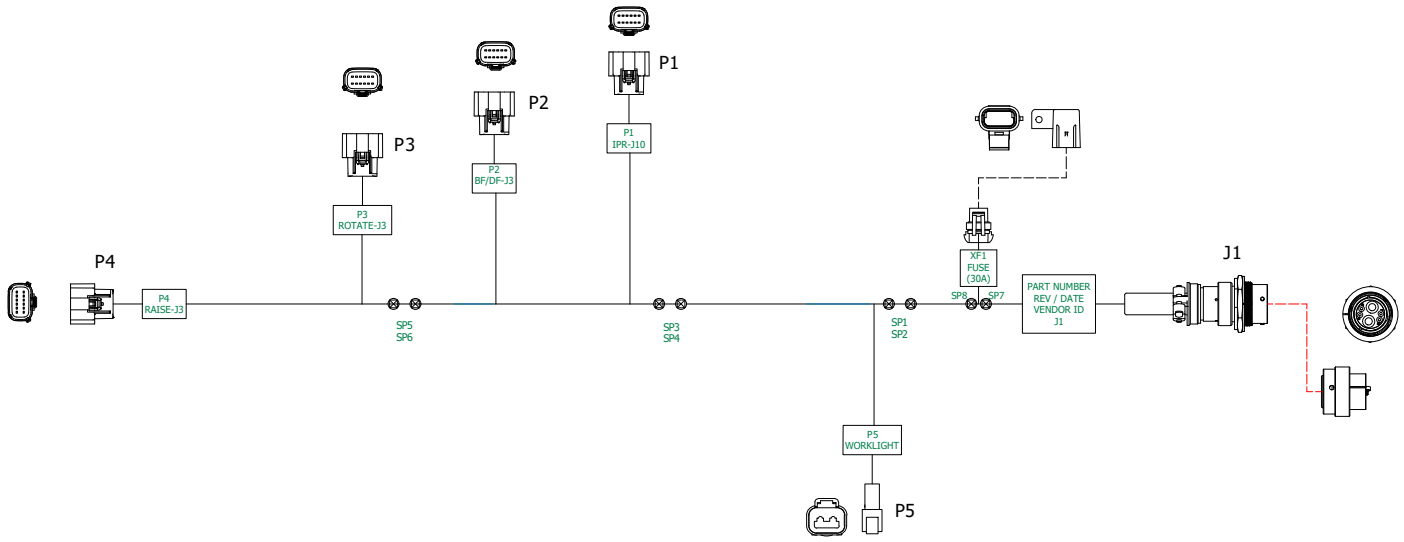

Wire Hookup Chart, P/N 10158001

Reference Designator	From	To	Gauge	Color	Function
W1	J1-3	SP7	6	Red	12V DC (Unprotected Power)
W2	SP7	XF1-1	12	Red	12V DC (Unprotected Power)
W3	XF1-2	SP8	12	Red	12V DC (Power)
W4	SP8	SP1	6	Red	12V DC (Power)
W5	J1-4	SP2	6	Black	12V DC (Ground)
W6	SP1	P5-2	16	Red	Worklight (Power)
W7	SP1	SP3	8	Red	12V DC (Power)
W8	SP2	P5-1	16	Black	Worklight (Ground)
W9	SP2	SP4	8	Black	12V DC (Ground)
W10	SP3	P1-1	18	Red	IPR (Power)
W11	SP3	P2-1	16	Red	BF Dry Fertilizer IPN (Power)
W12	SP3	P2-3	16	Red	BF Dry Fertilizer IPN (Power)
W13	SP3	SP5	12	Red	AUX IPN (Power)
W14	SP4	P1-2	18	Black	IPR (Ground)
W15	SP4	P2-2	16	Black	BF Dry Fertilizer IPN (Ground)
W16	SP4	P2-4	16	Black	BF Dry Fertilizer IPN (Ground)
W17	SP4	SP6	12	Black	AUX IPN (Ground)
W18	SP5	P3-1	16	Red	Rotation IPN (Power)
W19	SP5	P3-3	16	Red	Rotation IPN (Power)
W20	SP5	P4-1	16	Red	Raise IPN (Power)
W21	SP5	P4-3	16	Red	Raise IPN (Power)
W22	SP6	P3-2	16	Black	Rotation IPN (Ground)
W23	SP6	P3-4	16	Black	Rotation IPN (Ground)
W24	SP6	P4-2	16	Black	Raise IPN (Ground)
W25	SP6	P4-4	16	Black	Raise IPN (Ground)

LED Worklight Harness

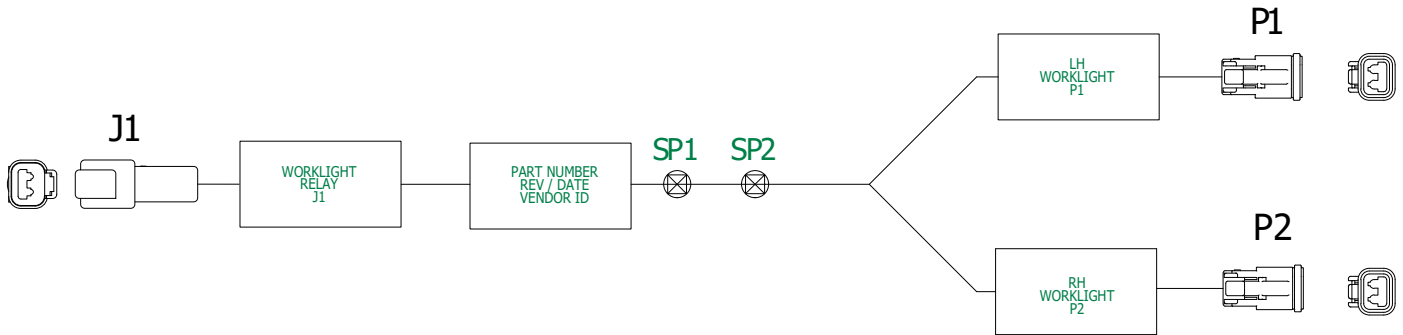

Wire Hookup Chart, P/N 10171901

Reference Designator	From	To	Gauge	Color	Function
W1	J1-1	SP1	16	Black	12V DC (-)
W2	J1-2	SP2	16	Red	12V DC (+)
W3	SP1	P1-1	16	Black	Worklight (-)
W4	SP1	P2-1	16	Black	Worklight (-)
W5	SP2	P1-2	16	Red	Worklight (+)
W6	SP2	P2-2	16	Red	Worklight (+)

Bulk Fill Scale Harness

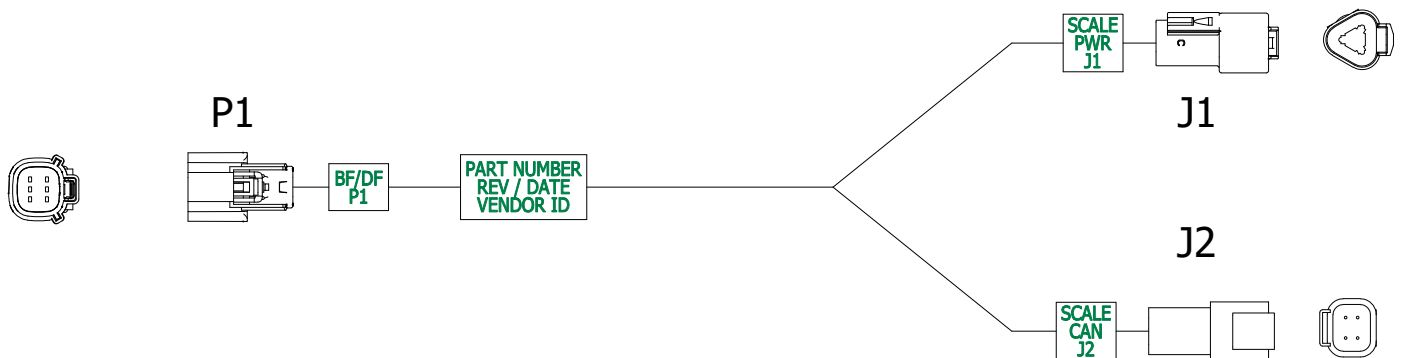

Wire Hookup Chart, P/N A24485

Reference Designator	From	To	Gauge	Color	Function
W1	P1-1	J2-1	18	Yellow	BF Scale (CAN H)
W2	P1-2	J2-2	18	Green	BF Scale (CAN L)
W3	P1-3	J1-A	18	Red	BF Scale Head (Power)
W4	P1-4	J1-B	18	Black	BF Scale Head (Ground)

**Bulk Fill Scale CAN Cable**

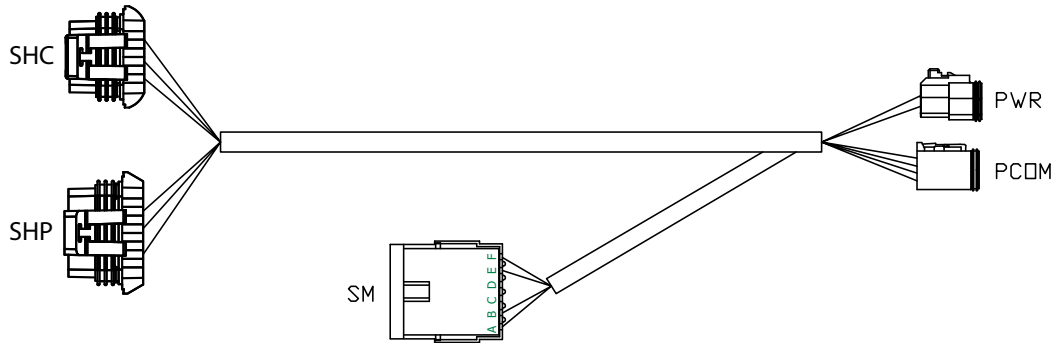

**Wire Hookup Chart, P/N A19388**

Signal	Gauge	Color	PWR	PCOM	SHC	SHP	SM
12V DC Power	16	Red	1			C, E	A
Ground	16	Black	2			F	B
CAN H	18	Yellow		1	A		E
CAN L	18	Green		2	H		F

**3605 Rotation Harness Adapter**

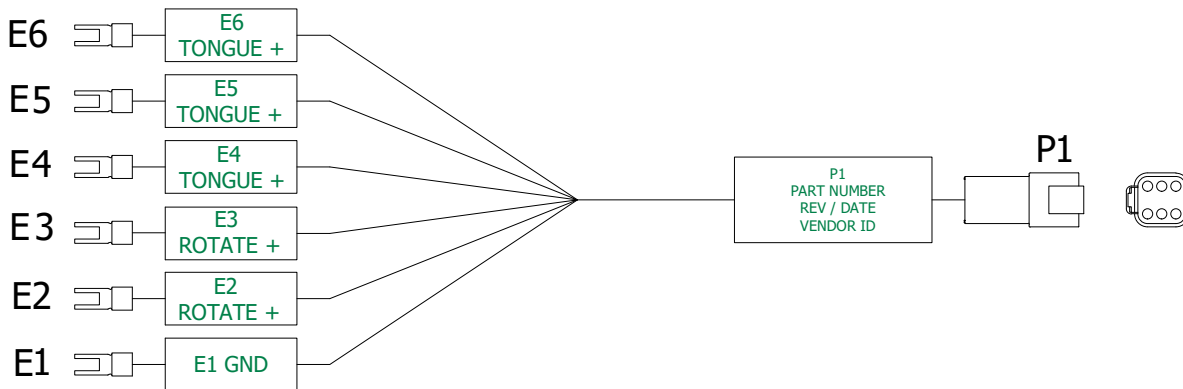

**Wire Hookup Chart, P/N 10150201**

Reference Designator	From	To	Gauge	Color	Function
W1	P1-1	E1	14	Black/Red	Terminal Block (Ground)
W2	P1-2	E2	14	Blue/Red	Rotation Solenoid (+)
W3	P1-3	E3	14	Blue/Red	Rotation Solenoid (+)
W4	P1-4	E4	14	Orange/Red	Tongue Solenoid (+)
W5	P1-5	E5	14	Orange/Red	Tongue Solenoid (+)
W6	P1-6	E6	14	Orange/Red	Tongue Solenoid (+)

Integrated True Depth Harness

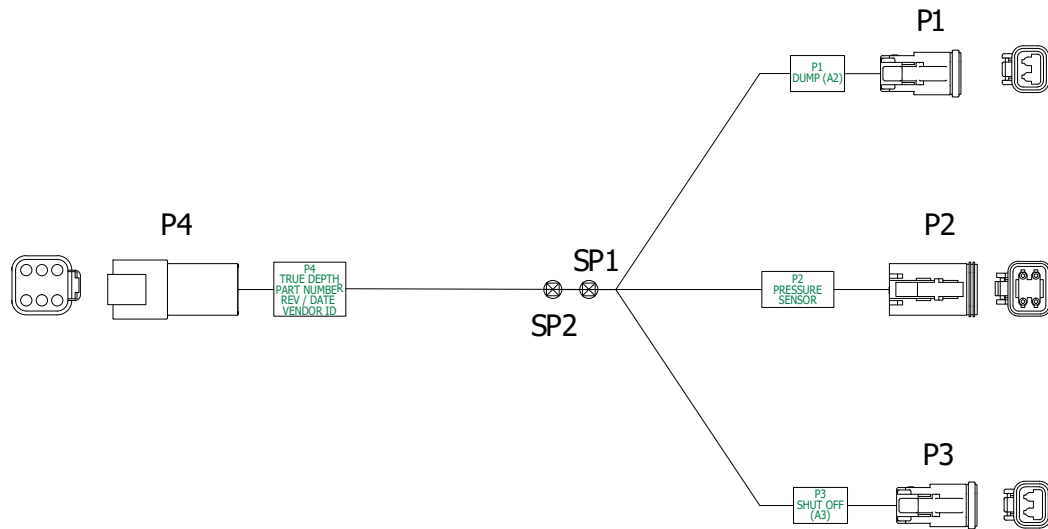

Wire Hookup Chart, P/N A26713

Reference Designator	From	To	Gauge	Color	Function
W1	P4-1	P2-1	18	White	HDP Sensor (Signal)
W2	P4-2	P2-2	18	Orange	HDP Sensor (Power)
W3	P4-3	P2-3	18	Black	HDP Sensor (Ground)
W4	P4-4	SP1	18	Violet	HDP PWM (+)
W5	SP1	P1-1	18	Violet	HDP PWM Dump Valve (+)
W6	SP1	P3-1	18	Violet	HDP PWM Shut Off (+)
W15	P4-5	SP2	18	Brown	HDP PWM (-)
W16	SP2	P1-2	18	Brown	HDP PWM Dump Valve (-)
W17	SP2	P3-2	18	Brown	HDP PWM Shut Off (-)

**Bulk Fill PDP Harness**

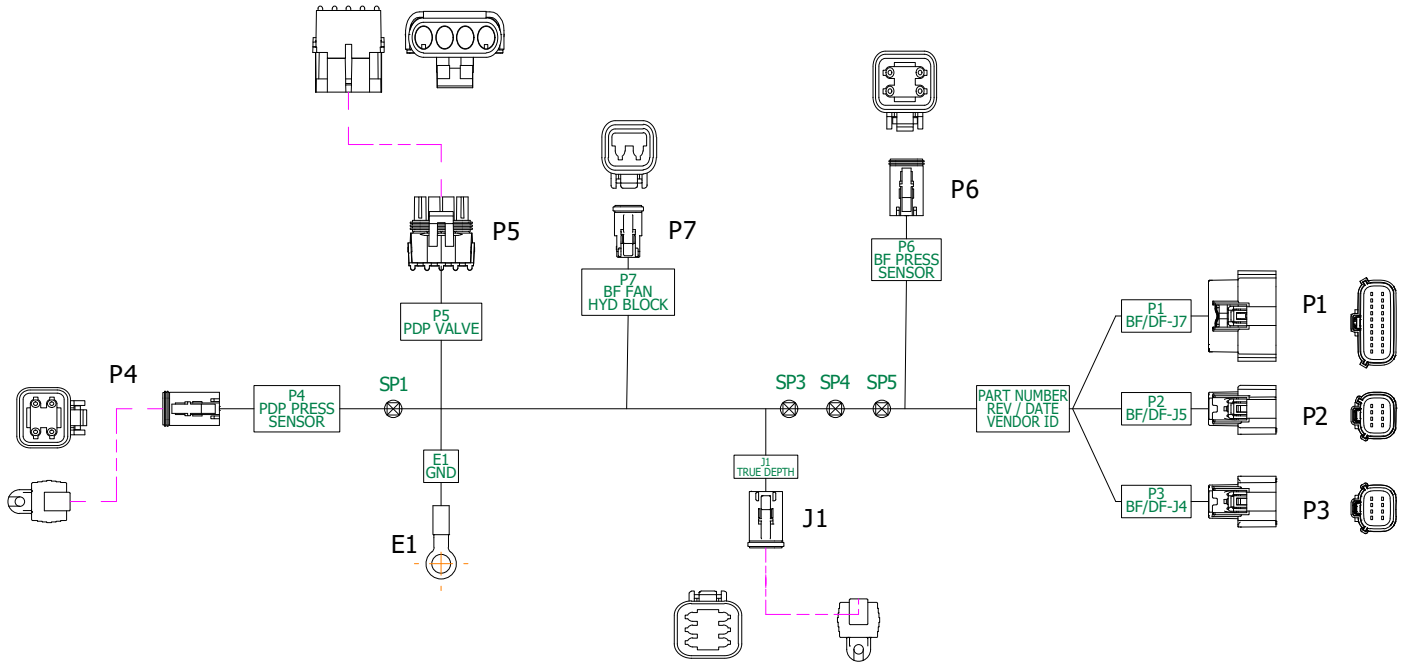

**Wire Hookup Chart, P/N 10260101**

Reference Designator	From	To	Gauge	Color	Function
W1	P1-3	SP3	16	Violet	PDP Decrease Solenoid (+)
W2	SP3	P5-C	16	Violet	PDP Decrease (+)
W3	SP3	J1-4	18	Violet	HDP PWM (+)
W4	P1-4	SP4	16	Brown	PDP Decrease Solenoid (-)
W5	SP4	P5-D	16	Brown	PDP Decrease (-)
W6	SP4	J1-5	18	Brown	HDP PWM (-)
W7	P1-16	SP5	18	White	PDP Sensor (Analog Signal)
W8	SP5	P4-4	18	White	PDP Sensor (Signal)
W9	SP5	J1-1	18	White	HDP Sensor (Signal)
W10	P1-19	SP1	18	Black	PDP Sensor (Ground)
W11	SP1	P4-1	18	Black	PDP Sensor (Ground)
W12	SP1	J1-3	18	Black	HDP Sensor (Ground)
W13	SP1	E1	18	Black	Ground
W14	P1-20	P4-2	18	Orange	PDP Sensor (Power)
W15	P1-18	J1-2	18	Orange	PDP Sensor (Power)
W16	P2-1	P5-A	16	Red	PDP Increase Solenoid (+)
W17	P2-2	P5-B	16	Yellow	PDP Increase Solenoid (-)
W18	P2-5	P6-2	18	White	BF Pressure Sensor (Power)
W19	P2-6	P6-1	18	Black	BF Pressure Sensor (Ground)
W20	P2-7	P6-4	18	Yellow	BF Pressure Sensor (Analog Signal)
W21	P3-1	P7-1	16	Red	BF Fan Solenoid (+)
W22	P3-2	P7-2	16	Black	BF Fan Solenoid (-)



12V Power Harness

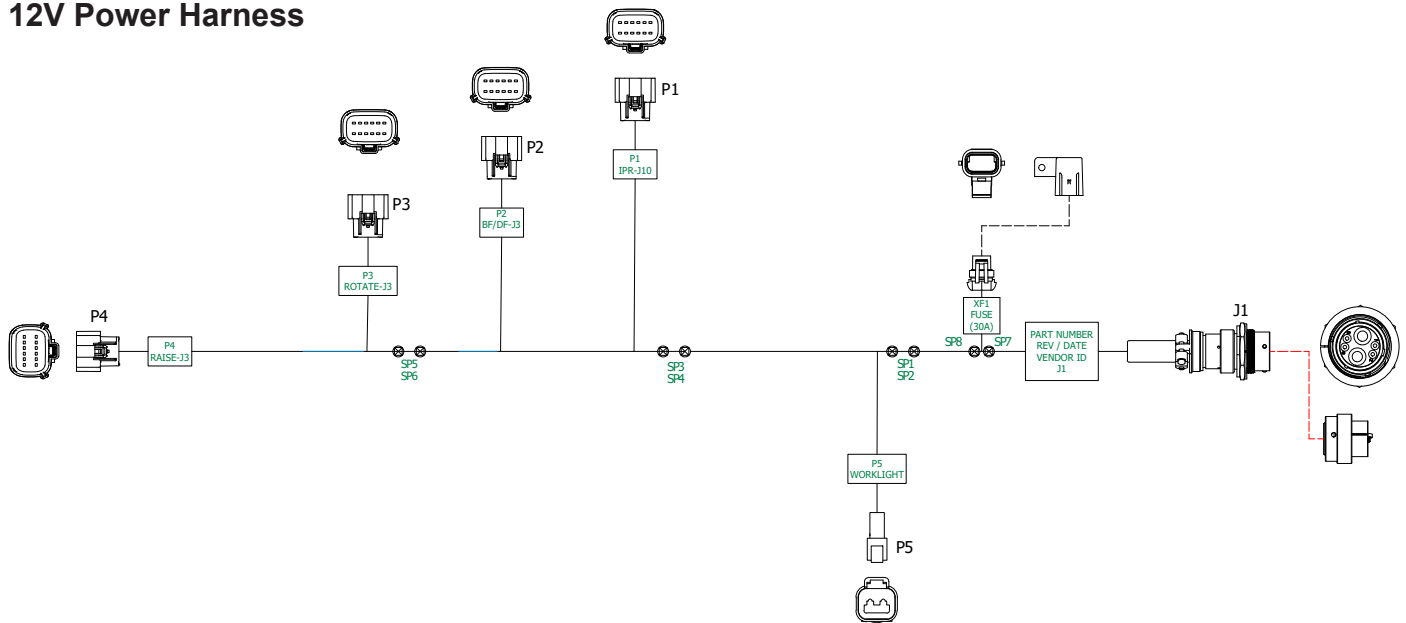

Wire Hookup Chart, P/N 10152701

Reference Designator	From	To	Gauge	Color	Function
W1	J1-3	SP7	6	Red	12V DC (Unprotected Power)
W2	SP7	XF1-1	12	Red	12V DC (Unprotected Power)
W3	XF1-2	SP8	12	Red	12V DC (Power)
W4	SP8	SP1	6	Red	12V DC (Power)
W5	J1-4	SP2	6	Black	12V DC (Ground)
W6	SP1	P5-2	16	Red	Worklight (Power)
W7	SP1	SP3	8	Red	12V DC (Power)
W8	SP2	P5-1	16	Black	Worklight (Ground)
W9	SP2	SP4	8	Black	12V DC (Ground)
W10	SP3	P1-1	18	Red	IPR (Power)
W11	SP3	P2-1	16	Red	BF Dry Fertilizer IPN (Power)
W12	SP3	P2-3	16	Red	BF Dry Fertilizer IPN (Power)
W13	SP3	SP5	12	Red	AUX IPN (Power)
W14	SP4	P1-2	18	Black	IPR (Ground)
W15	SP4	P2-2	16	Black	BF Dry Fertilizer IPN (Ground)
W16	SP4	P2-4	16	Black	BF Dry Fertilizer IPN (Ground)
W17	SP4	SP6	12	Black	AUX IPN (Ground)
W18	SP5	P3-1	16	Red	Rotate IPN (Power)
W19	SP5	P3-3	16	Red	Rotate IPN (Power)
W20	SP5	P4-1	16	Red	Raise IPN (Power)
W21	SP5	P4-3	16	Red	Raise IPN (Power)
W22	SP6	P3-2	16	Black	Rotate IPN (Ground)
W23	SP6	P3-4	16	Black	Rotate IPN (Ground)
W24	SP6	P4-2	16	Black	Raise IPN (Ground)
W25	SP6	P4-4	16	Black	Raise IPN (Ground)

**This page left blank intentionally.**

**BULK FILL**

<b>PROBLEM</b>	<b>POSSIBLE CAUSE</b>	<b>SOLUTION</b>
Seed does not travel through delivery tubes.	System pressure set too low.	Increase system pressure.
Seed stops flowing to row unit during planting.	Seed surging.	Shut down bulk fill system and restart system from idle; seed should start flowing.
	Debris in system.	Insert shutoff door, open cleanout door. remove plug.
Seed does not move from entrainer at startup after exposure to water.	Seed swelled in entrainer.	Insert shutoff door, open cleanout door. remove swelled seed.

**CLOSING WHEEL**

<b>PROBLEM</b>	<b>POSSIBLE CAUSE</b>	<b>SOLUTION</b>
Closing wheel(s) leave severe imprint in soil.	Too much closing wheel down pressure.	Adjust closing wheel pressure.
Closing wheel(s) not firming soil around seed.	Not enough closing wheel down pressure.	Adjust closing wheel pressure. Severe no till conditions may require use of cast iron closing wheels.
"V" closing wheel running on top of seed furrow.	Improper centering.	Align. See "V Closing Wheel Adjustment".
Single closing wheel not directly over seed.	Improper centering.	Align. See "Covering Discs/Single Press Wheel Adjustment".

**LIFT CIRCUIT**

<b>PROBLEM</b>	<b>POSSIBLE CAUSE</b>	<b>SOLUTION</b>
Right wing raises faster than left wing. Right wing may even raise completely before the center frame and left wing start to raise. If planter is loaded, the center frame and left wing may not be able to raise at all.	Master cylinder, located on front side of center post, leaking internally. NOTE: Make sure lift system is completely rephased.	Repair master cylinder.
Left wing raises faster than right wing. Left wing may even raise completely before the center frame and right wing start to raise. If the planter is loaded, the center frame and right wing may not be able to raise at all.	Master cylinder, located on rear side of center post, leaking internally. NOTE: Make sure the lift system is completely rephased.	Repair master cylinder.
Center frame raises, but wings do not.	Planter hydraulic circuit out of phase. Usually occurs when the planter is lowered from transport position.  Solenoid valve in port V16 leaking.	Hold hydraulic control in lowering position to give the hydraulic circuit more time to rephase.  Replace solenoid valve cartridge.
Center frame continues to raise after wing cylinders have reached full stroke when going to raised field position.	Solenoid valve in port V16 leaking.	Replace solenoid valve cartridge.
Planter raises to raised field position, but does not raise to transport position.	Solenoid valve coil in port V16 is not energized.	Be sure control console switch is in "raise" position to energize solenoid coil in port V16. Check control console fuse by moving auxiliary switch to ON position. If red light comes on the fuse is OK. Return auxiliary to OFF position. Check for poor wire connection or damaged wire and repair. Solenoid valve coil is defective. All solenoid valves used on the planter are the same. Switch the solenoid coil with one you know is working. If this cures the problem, replace defective coil.
	Solenoid valve cartridge in port V16 is stuck closed.	All solenoid valves used on the planter are the same. Switch the solenoid cartridge with one you know is working. If this cures the problem, replace defective cartridge.
Left wing lowering slower than center frame and right wing. If hydraulic lever is held in lowering position, left wing cylinder attempts to extend.	Check valve in port V17 leaking internally.	Remove check valve in port V17 and inspect for foreign material in valve and remove if possible. Replace check valve. If above fails, switch check valve in port V17 with check valve in port V15. If problem moves or switches to right wing, replace defective check valve.
Right wing lowering slower than center frame and left wing. If hydraulic control is held in lowering position, right wing cylinder attempts to extend.	Check valve in port V15 leaking internally.	Remove check valve in port V15 and inspect for foreign material in valve and remove if possible. Replace check valve. If above fails, switch check valve in port V15 with check valve in port V17. If problem moves or switches to right wing, replace defective check valve.
Planter does not raise or raises slowly.	Tractor may have hydraulic problem.	Switch remote outlets being used. Repair tractor hydraulics.
	Planter may be overloaded with hopper extensions and/or extra fertilizer tanks, coulters or other non-Kinze attachments.	Remove weight.
	Center pivot wear pads may be adjusted too tight and are binding on the post.	Adjust pads.

### PTO PUMP DRIVE AND OIL COOLER OPTION

PROBLEM	POSSIBLE CAUSE	SOLUTION
Pump is squealing.	Lack of oil to pump.	Check for plugged suction strainer. Check oil level.
Oil temperature is high.	Low oil level.	Check oil level and add as required.
Desired fan speed cannot be achieved.	Low oil level.	Check oil level and add as required.
	Plugged filter.	Check and change as required.

### POINT ROW CLUTCH

PROBLEM	POSSIBLE CAUSE	SOLUTION
No clutches disengage.	Main fuse blown in control console.	Replace defective fuse.
	Poor terminal connection in wiring harness.	Repair or replace.
	Wiring damage in wiring harness.	Repair or replace.
	Low voltage at coil. (12 volts required)	Check battery connections.
One section of planter will not re-engage.	Shear pin at seed drive transmission(s) sheared.	Replace pin with one of equal size and grade.
One clutch will not engage.	Fuses blown.	Replace defective fuses.
	Actuator arm and plunger stuck in disengaged position.	Remove, free up, and reinstall.
	Actuator arm out of adjustment.	Adjust actuator arm mounting pin in slot so that actuator arm clears stop on stop collar by approximately 1/8" when clutch is rotated.
	Wrap spring broken or stretched.	Disassemble clutch and replace spring.
	Something touching the stop collar.	Check to ensure collar is free to turn with clutch.
	Clutch assembled incorrectly.	Check clutch and diagram for correct assembly.
Clutch slipping.	Wrap spring stretched.	"Lock" clutch output shaft from turning. Place torque wrench on input shaft and rotate in direction of drive. After input shaft has rotated a short distance the wrap spring should tighten onto the input hub. If slippage occurs at less than 100 ft. lbs. replace spring. If spring still slips after installing new spring, replace input hub.
Planter section does not re-engage while planter is moving forward.	Spring in actuator arm not strong enough to push arm operational switch is turned to the ON position.	Remove spring from inside solenoid and stretch spring slightly or replace. Reinstall spring. If that fails, file the away from stop collar when stop on the stop collar slightly so that the stop is not as aggressive.
Frequent solenoid burnout.	Fuses too large.	Replace fuses on front panel with 10 amp slow blow fuses.
Frequent fuse burnout.	Low voltage (12 volts required).	Check power source voltage for partially discharged battery, etc.
	Damage to wiring harness.	Repair or replace harness.

**ROTATION CIRCUIT**

<b>PROBLEM</b>	<b>POSSIBLE CAUSE</b>	<b>SOLUTION</b>
Cylinder does not extend, but will retract.	Solenoid valve coil in port V12 defective.	Switch coil from port V12 with coil in port V9. If cylinder extends but will not retract, replace defective coil from port V12.
	Solenoid valve cartridge in port V12 stuck closed.	Switch cartridge from port V12 with cartridge in port V9. If cylinder extends but will not retract, replace defective cartridge from port V12.
Cylinder does not retract, but will extend.	Solenoid valve coil in port V9 defective.	Switch coil from port V9 with coil in port V12. If cylinder extends but will not retract, replace defective coil from port V9.
	Solenoid valve cartridge in port V9 stuck closed.	Switch cartridge from port V9 with cartridge in port V12. If cylinder extends but will not retract, replace defective cartridge from port V9.

**ROW MARKER OPERATION**

<b>PROBLEM</b>	<b>POSSIBLE CAUSE</b>	<b>SOLUTION</b>
Right marker lowering slower than left marker.	Solenoid valve cartridge in port V1 not opening completely.	Switch with cartridge in port V2. If problem repeats, replace cartridge.
	Hose pinched or collapsed.	Inspect hose routing. Replace or repair hoses as required.
Left marker lowering slower than right marker.	Solenoid valve cartridge in port V2 not opening completely.	Switch with cartridge in port V1. If problem repeats, replace cartridge.
	Hose pinched or collapsed.	Inspect hose routing. Replace or repair hoses as required.
Both markers lowering.	Solenoid valve cartridge stuck open. If left marker switch is selected, right cartridge (V1) is defective. If right marker switch is selected, left cartridge (V2) is defective.	Replace solenoid valve cartridge.
Neither marker lowers.	Blown fuse.	Check red light on control console. It should be on if switch is on. If light is not on, switch to opposite marker position. If light comes on, switch may be defective. Replace switch. Otherwise replace fuse.
	Coils at V1 and V2 not energized.	Poor ground on wire, bad wire connection or damaged wire. Repair as required.
	Marker flow control valve closed too far.	See Operation Section for adjustment.
Neither marker will raise.	Marker flow control valve closed too far.	See Operation Section for adjustment.
Right marker will not lower.	Solenoid coil in port V1 not energized.	Check switch on control console. Replace if defective. Check coil ground wire. Check for poor connection or damaged wire.
	Solenoid cartridge in port V1 stuck closed.	Switch cartridge with one on the planter you know is operating properly. If right marker lowers, replace defective cartridge.
Left marker will not lower.	Solenoid coil in port V2 not energized.	Check switch on control console. Replace if defective. Check coil ground wire. Check for poor connection or damaged wire.
	Solenoid cartridge in port V2 stuck closed.	Switch cartridge with one on the planter you know is operating properly. If left marker lowers, replace defective cartridge.
Markers traveling too fast and damaging rubber stop on transport stands and/or damaging pivot at rod end of marker cylinders.	Marker transport stand not adjusted correctly to allow marker cushion cylinders to operate as designed.	See "Row Marker Transport Stand Adjustment".
	Marker flow control valve needs adjustment.	See Operation Section for adjustment.

**SOLENOID VALVE**

<b>PROBLEM</b>	<b>POSSIBLE CAUSE</b>	<b>SOLUTION</b>
No solenoids operate.	Low voltage.	Must be connected to 12 volt DC only. Negative ground.
	Blown fuse.	Replace control console fuse with AGC-15 amp.
	Battery connection.	Clean and tighten.
	Wiring harness damaged.	Repair or replace.
One solenoid valve will not operate.	Bad switch.	Replace on control panel.
	Cut wire in harness.	Locate and repair.
	Bad coil.	Replace.
	Poor connection at coil.	Check.
Valve operating when not energized.	Valve stem stuck open.	Replace cartridge.
	O-ring leaking.	Install new O-ring kit.
	Foreign material under poppet.	Remove and clean cartridge.

**WING LOCK CYLINDER CIRCUIT**

<b>PROBLEM</b>	<b>POSSIBLE CAUSE</b>	<b>SOLUTION</b>
Cylinders will not extend or retract.	No power to the solenoid valve coils.	Auxiliary switch may be in the ON position. Must be in OFF position. Check fuse at control console. Replace fuse with 15 amp type AGC if blown. Check for poor wire connection or damaged wire. Repair as required.
Cylinders will not extend.	Solenoid valve coil in port V3 not energized.	Check for power to coil. Check coil ground wire. If OK, switch coil from port V3 with coil from port V4. If cylinders extend but will not retract, replace defective coil.
	Solenoid valve cartridge in port V3 stuck closed.	Switch cartridge in port V3 with cartridge in port V4. If cylinders extend but will not retract, replace defective cartridge.
Cylinders will not retract.	Solenoid valve coil in port V4 not energized.	Check for power to coil. Check coil ground wire. If OK, switch coil from port V4 with coil from port V3. If cylinders retract but will not extend, replace defective coil.
	Solenoid valve cartridge in port V4 stuck closed.	Switch cartridge in port V4 with cartridge in port V3. If cylinders retract but will not extend, replace defective cartridge.
Cylinders retract with the switch off.	Solenoid valve cartridge in port V4 stuck open.	Replace solenoid valve cartridge.
Cylinders extend with the switch off.	Solenoid valve cartridge in port V3 stuck open.	Replace solenoid valve cartridge.

**SEED METER (VACUUM)**

<b>PROBLEM</b>	<b>POSSIBLE CAUSE</b>	<b>SOLUTION</b>
Low seed count.	Meter RPM too high.	Reduce planting rate or planting speed.
	Singulator brush setting too aggressive.	Adjust singulator brush.
	Vacuum level too low.	Increase fan speed.
	Seed sensor not picking up all seeds dropped.	Clean seed tube. Move meter to different row.
	Seeds sticking to seed disc.	Use graphite or talc to aid release.
	Seed treatment buildup in seed disc recesses.	Reduce amount of treatment used and or mix thoroughly. Add talc.
	Seed size too large for disc used.	Use appropriate disc for seed size.
	Wrong transmission setting.	Change transmission to desired rate.
	Wrong seed disc.	Use appropriate disc for seed type and size.
	Drive wheel slippage.	Compensate by adjusting transmission sprockets.
	Low tire pressure.	Adjust tire pressure to correct level.
	Failed/worn drive components.	Inspect and replace parts as required.
	Plugged orifices in seed disc.	Inspect and clean disc. Check cleanout brush. (If Applicable)
	Loss of vacuum at meter.	Check for foreign material between vacuum cover and disc. Inspect parts for wear/damage. Clean or replace as required.
	Seed bridging in hopper.	Add graphite to improve seed flow.
	Faulty vacuum gauge reading.	Repair/replace gauge.
	Dirt in vacuum manifold.	Check vacuum manifold for dirt and clean.
	Seed baffle (If Applicable) not allowing seed flow due to bridging of seed.	Thoroughly mix talc to coat all seeds. Remove seed baffle. See "Seed Meter" in Operation/Maintenance section.
	60 cell soybean disc not filling properly due to excessive RPM.	Replace with 120 cell soybean disc.
	Seed disc worn.	Replace.
Vacuum cover worn.	Replace.	
Not planting seed.	Seed hoppers empty.	Fill seed hopper.
	Seed tube plugged/damaged.	Clean or replace tube.
	Meter drive damaged.	Repair/replace drive components.
	Low/no vacuum.	Inspect vacuum system and repair as necessary.
	Singulator brush setting too aggressive.	Adjust singulator brush.
	Faulty vacuum gauge.	Repair/replace vacuum gauge.
	Seed bridging in hopper.	Add graphite to improve seed flow.
	Loss of vacuum at meter.	Check for foreign material between vacuum cover and disc. Inspect parts for wear/ damage. Clean and/or replace as required.
	Wrong seed disc.	Use appropriate disc for seed type and size.
	Meter drive clutch not engaged.	Engage drive clutch.
	Fan not running.	Start fan.
	Dirt in vacuum manifold.	Check vacuum manifold for dirt and clean.

Continued on next page.



**SEED METER (VACUUM) - Continued**

<b>PROBLEM</b>	<b>POSSIBLE CAUSE</b>	<b>SOLUTION</b>
Not planting seed. (Continued)	Seed baffle (If Applicable) not allowing seed flow due to bridging of seed.	Thoroughly mix talc to coat all seeds. Remove seed baffle. See "Seed Meter" in Seed Meter Operation/Maintenance section.
	60 cell soybean disc not filling properly due to excessive RPM.	Replace with 120 cell soybean disc.
High seed count.	Wrong transmission setting.	Change transmission to desired rate.
	High vacuum.	Adjust vacuum level to appropriate level.
	Wrong seed disc.	Replace seed disc.
	Singulator brush setting not aggressive enough.	Adjust singulator brush.
	Worn singulator brush.	Inspect brush and replace as required.
	Seed leaking past wall brush.	Inspect wall brush condition and installation. Replace as necessary.
	Faulty vacuum gauge.	Check gauge line for dirt/obstruction. Repair/replace vacuum gauge.
Poor seed spacing.	Obstruction in seed tube.	Clean seed tube.
	Dirty/damaged seed disc.	Inspect seed disc for damage, foreign material in orifices or seed treatment buildup in recesses. Clean or replace.
	Wrong vacuum setting.	Adjust vacuum to appropriate level.
	Excess foreign material in seed.	Inspect and clean meter and seed discs. Use clean, undamaged seed.
	Incorrect singulator brush setting.	Adjust singulator brush to appropriate setting.
	Inconsistent driveline.	Inspect drive components for rust, misalignment, worn or damaged parts. Replace/repair as required.
	Toolbar not level or wrong height.	Adjust hitch to level toolbar and row units.
	Planting too fast for conditions.	Reduce speed.
	Rough field conditions.	Reduce speed.
Irregular seed population.	Driving too fast.	Reduce speed.
	Drive wheels slipping.	Reduce speed. Decrease row unit down pressure spring settings.
Unable to achieve desired vacuum level.	Tractor hydraulic flow set too low.	Increase flow to fan motor.
	Incorrect hydraulic connections.	Check all hydraulic connections and hose routings.
	Damaged fan components.	Inspect motor and impeller for wear/damage and repair/replace as necessary.
	Vacuum hose pinched/kinked/blocked.	Inspect air lines for any damage or obstruction. Clean air lines and manifold by removing end cap from manifold and running fan at high speed.
	Vacuum hose loose/disconnected.	Inspect and reattach all air hoses.
	Tractor not producing required hydraulic flow/pressure.	Have tractor serviced by qualified technician.
	Dirt in vacuum gauge line.	Check gauge line for dirt/obstruction and clean.

**TONGUE CYLINDER CIRCUIT**

<b>PROBLEM</b>	<b>POSSIBLE CAUSE</b>	<b>SOLUTION</b>
Tongue cylinder will not extend, but will retract.	No power to solenoid valve coil in port V10 and/or V14. Both must be energized.	Check wiring between control console and solenoid coils looking for damaged wires and poor connections.
	Solenoid valve coil defective.	Switch coil from port V13 with V10. If tongue still will not extend, switch coil from V14 with V13. It will not be necessary to remove any of the wire connections to the solenoid. All three of these solenoids are normally energized when the tongue switch is energized. Replace defective coil.
	Solenoid valve cartridges in port V10 and/or V14 stuck closed.	Switch cartridge from port V10 with cartridge in port V13. If tongue cylinder retracts, replace defective cartridge from port V10. If problem continues, switch cartridge from port V14 with cartridge in port V13. Replace defective cartridge.
Tongue cylinder will not extend but tongue lock cylinder extends.	Pressure relief valve in port V11 stuck closed or pressure setting too high. (Valve is factory set to open at 1000 PSI.)	Replace or adjust pressure relief valve. To adjust, loosen lock nut and turn counter clockwise to decrease pressure.
Tongue hook does not release before the tongue starts to extend.	Solenoid valve cartridge in port V11 stuck open or pressure setting too low. (Valve is factory set to open at 1000 PSI.)	Replace or adjust pressure relief valve. To adjust, loosen lock nut and turn clockwise to increase pressure.
Tongue cylinder will not retract, but will extend.	Solenoid valve coil in port V13 defective.	Switch coil from port V13 with coil from port V14. If coil from port V13 is bad, the tongue will extend but not retract. Replace defective coil.
	Solenoid valve cartridge in port V13 stuck closed.	Switch cartridge from port V13 with cartridge from port V14. If cartridge is bad, the tongue will extend but not retract. Replace defective cartridge.
Tongue extends with switch off.	Solenoid valve cartridge in port V10 and V14 stuck open.	Replace solenoid valve cartridge.
Tongue retracts with switch off.	Solenoid valve cartridge in port V13 stuck open.	Replace solenoid valve cartridge.

### DIAPHRAGM FERTILIZER PUMP

PROBLEM	POSSIBLE CAUSE	SOLUTION
The pump does not prime properly.	Intake circuit not airtight.	Tighten, repair or replace hoses and fittings as necessary.
	Control unit switching lever on "Pressure" setting.	Move control switching lever to "By-pass" setting.
The pump does not reach the required pressure.	Seat and plate of intake and delivery valves worn.	Replace the worn valves.(1)
	Nozzles worn or too large in diameter.	Replace the worn nozzles. Use nozzles of suitable diameter.
	Restriction in intake circuit.	Remove the restriction from the circuit.
	Intake filter fouled.	Clean the filter cartridge
Pressure gauge needle wobbles, pressure pulsating.	Intake circuit not airtight.	Clean or replace the intake and delivery valves. (1)
	Residual air left inside pump.	Discharge the air by opening a ball valve/central unit connected to the delivery side with the pump in operation.
	Valve plate stuck to its seat.	Tighten, repair or replace hoses and fittings as necessary.
	Pressure accumulator deflated.	Inflate accumulator to the correct pressure.
Uneven flow of liquid to nozzles.	Pressure accumulator deflated.	Inflate accumulator to the correct pressure.
Increase in noise and simultaneous drop in oil level (pump cavitation).	Restriction in intake circuit.	Remove the restriction from the circuit.
	Intake filter fouled.	Clean the filter cartridge
	Pump drawing in liquid from too low a level.	See "Pump Intake Conditions" section.
Oil on pump body or base.	Oil seal on pump shaft worn	Replace the worn oil seal
	Oil pressure inside pump too high.	Restore correct oil level in tank.
Pump using too much oil (oil flowing from delivery port) or oil whitish in color (water/oil emulsion in tank).	One or more diaphragms ruptured.	Stop the pump at once. Replace the diaphragms (1)

**This page left blank intentionally.**