

# MODEL 851/1051 GRAIN CARTS OPERATOR MANUAL

**M0276-01**

**Rev. 3/26**

This manual is applicable to: 2017 Production and on

Record model number and serial number of your grain cart along with date purchased:

Model Number \_\_\_\_\_

Serial Number \_\_\_\_\_

Date Purchased \_\_\_\_\_

## SERIAL NUMBER

Record your serial number and purchase date above for quick reference.

The serial number provides important information about your grain cart and is required to obtain correct replacement parts. Always provide model and serial number to your Kinze Dealer when ordering parts or anytime correspondence is made with Kinze Manufacturing, Inc.



**Serial Number Plate Location**

*Kinze® and the Kinze® logo are registered trademarks of Kinze Manufacturing, Inc.*

*Shur-Co® , LLC is a registered trademark of Shur-Co.*

*Digi-Star® , LLC is a registered trademark of Digi-Star.*

*Camoplast® is a registered trademark of Camoplast Solideal Inc.*

*All other trademarks are the property of their respective owners.*

**Page intentionally blank.**

# 851-1051 Grain Cart

## TO THE DEALER

Predelivery service includes assembly, lubrication, adjustment and test. This service ensures cart is delivered to retail customer/end user ready for field use.

## PREDELIVERY CHECKLIST

Use this checklist to inspect cart after it is completely assembled. Check off each item as it is found satisfactory or after proper adjustment is made.

- Wheel nuts tightened to correct torque. Refer to ["Mounting Bolts and Hardware" on page 3-38.](#)
- Tires inflated to specified air pressure. Refer to ["Tire Servicing" on page 3-41.](#) (If Applicable)
- All grease fittings lubricated and gearbox oil level checked. Refer to ["Grease Fittings" on page 3-3.](#)
- All safety decals and SMV sign are correctly located and legible. Replace if damaged.
- SMV decal is in place and shipping cover removed.
- Safety/warning lights working properly.
- Test run augers. Do not operate tractor PTO above 750 PTO RPM with augers empty.
- Check driveline. See "Driveline Inspection" in Operation section.
- Check track alignment. See "Track Alignment" in Maintenance section. (If Applicable)
- Safety screens over auger are in place and properly secured.
- Auxiliary safety chains are properly installed and hardware torqued to specification.
- Paint all parts scratched in shipment.

*This wagon has been thoroughly checked and to the best of my knowledge is ready for delivery to the customer.*

(Signature Of Set-Up Person/Dealer Name/Date)

\_\_\_\_\_

## OWNER REGISTER

Name \_\_\_\_\_ Delivery Date \_\_\_\_\_

Street Address \_\_\_\_\_ Model No. \_\_\_\_\_ Serial No. \_\_\_\_\_

City, State/Province \_\_\_\_\_ Dealer Name \_\_\_\_\_

ZIP/Postal Code \_\_\_\_\_ Dealer No. \_\_\_\_\_

---

## DELIVERY CHECKLIST

Check off each item as it is fully explained to retail customer/end user when grain cart is delivered.

- Durability and longevity is dependent on regular maintenance as directed in Operator Manual.
- Tell retail customer/end user about all safety precautions that must be observed while using this cart.
- Advise retail customer/end user of specified tractor requirement for use with this cart.
- Along with retail customer/end user check reflective decals and SMV sign are clearly visible with cart attached to tractor. Check safety/warning lights are in working condition. Tell retail customer/end user to check and follow federal, state/provincial, and local regulations before towing on a road or highway.
- Along retail customer/end user check hitch height when attached to tractor is sufficient to prevent severe bends in PTO U-joint angles. Check PTO is correct length for making turns and operating on uneven terrain.
- Give Operator and Parts Manuals to retail customer/end user and explain all operating adjustments.
- Complete Warranty And Delivery Report form.

(Signature Of Delivery Person/Dealer Name/Date)

---

## AFTER DELIVERY CHECKLIST

Suggested items to check during first season of use:

- Check cart performance with retail customer/end user.
- Review with retail customer/end user importance of proper maintenance and adherence with all safety precautions.
- Check for parts that may need to be adjusted or replaced.
- Retighten all wheel nuts to specified torque.
- Safety shields and screens are in place.
- Safety and reflective decals, and SMV sign are correctly located and decals are legible. Replace if damaged or missing.
- Check safety/warning lights are properly installed and working properly.
- Check recommended lubrication procedures are being followed.

(Signature Of Follow-Up Person/Dealer Name/Date)

---

**All registrations must be submitted online at ["business.kinze.com"](http://business.kinze.com) within 5 business days of delivery.**

**Retain a copy of this form for auditing purposes.**

**OVERVIEW**

To the Owner ..... 1-1  
 Warranty ..... 1-3  
 General Information ..... 1-3  
 Introduction ..... 1-3  
 Specifications ..... 1-4  
 General Safety Rules ..... 1-5  
 Safety Instructions, Signs, and Decals ..... 1-6

**OPERATION**

Shipping Tie Downs ..... 2-1  
 Shipping Location ..... 2-1  
 Machine Preparation ..... 2-2  
 Tractor Requirements ..... 2-2  
 Tractor Preparation and Hookup ..... 2-2  
 Cart Operation ..... 2-5  
 Auger Fold Enable/Disable ..... 2-7  
 Unload Grain Cart ..... 2-8  
 PTO Torque Limiting/Overrunning Clutch Protection ..... 2-9  
 Auger Cleanout Door ..... 2-10  
 Vertical Auger Work Light ..... 2-12  
 Cameras ..... 2-12  
 Manual and Electric Roll Tarp ..... 2-13  
 Roll Tarp Remote Control Troubleshooting ..... 2-15  
 Track System Components ..... 2-16  
 Track System Operational Guidelines ..... 2-19  
 Electronic Scale - GT 400 ..... 2-20  
 Grain Moisture Sensor ..... 2-24  
 Grain Moisture Sensor Testing ..... 2-25  
 Grain Moisture Sensor Calibration ..... 2-26  
 Electronic Scale Printing Options ..... 2-27  
 Electronic Scale - GT 560 AutoLog ..... 2-28  
 Electronic Scale Troubleshooting ..... 2-31  
 Electronic Scale Troubleshooting ..... 2-32  
 Data Downloader Troubleshooting ..... 2-36  
 Track System Troubleshooting ..... 2-37

**LUBRICATION AND MAINTENANCE**

Wheel Bearings ..... 3-1  
 Gearbox Oil Level ..... 3-2  
 PTO Shaft Coupling ..... 3-2  
 Grease Fittings ..... 3-3  
 Lubrication Points ..... 3-4  
 Track System Maintenance - CAMSO ..... 3-6  
 Track System Maintenance - TDS ..... 3-8  
 Check Track Alignment ..... 3-11  
 Track System Torque Values - TDS ..... 3-12

Track Alignment Procedure - Camso ..... 3-14  
 Track Alignment Procedure - TDS ..... 3-15  
 Track System Inspection ..... 3-16  
 Off Season Storage for Tracks ..... 3-17  
 Track Removal ..... 3-18  
 Track Installation ..... 3-21  
 Idler Wheel Seal and Bearing  
     Removal and Installation - Camso ..... 3-22  
 Mid-Roller Wheel Seal and Bearing Installation - Camso ..... 3-24  
 Metal Face Seal Preparation and Installation - Camso ..... 3-26  
 Mid-Roller Wheel Seal and Bearing  
     Removal and Installation - TDS ..... 3-30  
 Idler Wheel Seal and Bearing  
     Removal and Installation - TDS ..... 3-33  
 Top Roller Wheel and Seal Removal - Camso ..... 3-34  
 Top Roller Wheel and Seal Removal - TDS ..... 3-37  
 Mounting Bolts and Hardware ..... 3-38  
 Torque Values Chart - Plated Hardware ..... 3-38  
 Special Torque Values ..... 3-38  
 Vertical Auger Counter Balance Valves ..... 3-40  
 Wheel Servicing ..... 3-40  
 Tire Servicing ..... 3-41  
 Driveline Inspection ..... 3-42  
 Upper Vertical Auger Replacement ..... 3-43  
 Lower Vertical Auger Replacement ..... 3-44  
 Wheel Bearing Replacement ..... 3-45  
 Preparation for Storage ..... 3-46  
 Hydraulic Control Schematic - Manual ..... 3-49  
 Wiring Diagram ..... 3-50  
 Electronic Schematic ..... 3-51  
 Moisture Sensor Harness Routing ..... 3-52  
 Autolog Sensor Harness Routing ..... 3-53  
 Electronic Scale ..... 3-54





**This page intentionally blank.**

Kinze Manufacturing, Inc. thanks you for your patronage. We appreciate your confidence in Kinze farm machinery. Your Kinze grain cart has been carefully designed to provide dependable operation in return for your investment.

**This manual has been prepared to aid you in the operation and maintenance of the grain cart. It should be considered a permanent part of the machine and remain with the machine when you sell it.**

It is the responsibility of the user to read and understand the Operator Manual in regards to safety, operation, lubrication and maintenance before operation of this equipment. It is the user's responsibility to inspect and service the machine routinely as directed in the Operator Manual. We have attempted to cover all areas of safety, operation, lubrication and maintenance; however, there may be times when special care must be taken to fit your conditions.

Throughout this manual the symbol  and the words **DANGER**, **WARNING**, and **CAUTION** are used to call attention to safety information that if not followed, will or could result in death or injury. **NOTICE** and **NOTE** are used to call your attention to important information. The definition of each of these terms follows:

	<p>Indicates an imminently hazardous situation that, if not avoided, will result in death or serious injury. This signal word is to be limited to the most extreme situations, typically for machine components which, for functional purposes, cannot be guarded.</p>
	<p>Indicates a potentially hazardous situation that, if not avoided, could result in death or serious injury, and includes hazards that are exposed when guards are removed. It may also be used to alert against unsafe practices.</p>
	<p>Indicates a potentially hazardous situation that, if not avoided, may result in minor or moderate injury. It may also be used to alert against unsafe practices.</p>
	<p>Used to address safety practices not related to personal injury.</p>

**NOTE:** Special point of information or machine adjustment instructions.



Improperly operating or working on this equipment could result in death or serious injury. Read and follow all instructions in Operator Manual before operating or working on this equipment.



Some photos in this manual may show safety covers, shields, or lockup devices removed for visual clarity. **NEVER OPERATE OR WORK ON** machine without all safety covers, shields, and lockup device in place as required.

**NOTE:** Photos in this manual may be of prototype machines. Production machines may vary in appearance.

**NOTE:** Some photos and illustrations in this manual show optional attachments installed. Contact your Kinze Dealer for purchase of optional attachments.

## Warranty

The Kinze Limited Warranty for your new machine is stated on the retail purchaser's copy of the Warranty And Delivery Receipt form. Additional copies of the Limited Warranty can be obtained through your Kinze Dealer.

Warranty, within the warranty period, is provided as part of Kinze's support program for registered Kinze products which have been operated and maintained as described in this manual. Evidence of equipment abuse or modification beyond original factory specifications will void the warranty. Normal maintenance, service and repair is not covered by Kinze warranty.

To register your Kinze product for warranty, a Warranty And Delivery Receipt form must be completed by the Kinze Dealer and signed by the retail purchaser, with copies to the Dealer, and to the retail purchaser. Registration must be completed and submitted to Kinze Manufacturing, Inc. within 5 business days of delivery of the Kinze product to the retail purchaser. Kinze Manufacturing, Inc. reserves the right to refuse warranty on serial numbered products which have not been properly registered.

If service or replacement of failed parts which are covered by the Limited Warranty are required, it is the user's responsibility to deliver the machine along with the retail purchaser's copy of the Warranty And Delivery Receipt to the Kinze Dealer for service. Kinze warranty does not include cost of travel time, mileage, hauling or labor. Any prior arrangement made between the Dealer and the retail purchaser in which the Dealer agrees to absorb all or part of this expense should be considered a courtesy to the retail purchaser.

*Kinze warranty does not include cost of travel time, mileage, hauling, or labor.*

## General Information



**Model 1051 Corner Auger Grain Cart**

Information used in these instructions was current at time of printing. However, due to Kinze's ongoing product improvement, production changes may cause your machine to appear slightly different in detail. Kinze Manufacturing, Inc. reserves the right to change specifications or design without notice and without incurring obligation to install the same on machines previously manufactured.

Right hand (R.H.) and left hand (L.H.), as used throughout this manual, are determined by facing direction machine travels in use unless otherwise stated.



Feature	Specification		
	851	1051	
Total Capacity*	850 Bushels (29.9 m <sup>3</sup> )	1050 Bushels (36.9 m <sup>3</sup> )	
Bushels/Minute - Average*	450 Bushels/minute	475 Bushels/minute	
Vertical Auger	20" Dia flighting in 21" Dia. tube	20" Dia flighting in 21" Dia. tube	
Bearings - Vertical Auger	2"	2"	
Gearbox	Bevel and spur gear with 2:1 ratio	Bevel and spur gear with 2:1 ratio	
PTO - 1000 RPM	PTO auger drive with overrunning and torque limiting clutch	PTO auger drive with overrunning and torque limiting clutch	
PTO Yoke	1¾"-20 spline	1¾"-20 spline	
Spindle	Two 4½" high alloy	Two 4½" high alloy	
Hub	20 bolt 13.189 bolt center (2) cast ductile iron	20 bolt 13.189 bolt center (2) cast ductile iron	
Safety Chains	Two ½" grade 70 transport chains	Two ½" grade 70 transport chains	
Adjustable Discharge Spout	Remotely adjustable spout with in/out motion and fitted with flexible discharge nozzle	Remotely adjustable spout with in/out motion and fitted with flexible discharge nozzle	
Tire Size/Pressure	IF900/65R 32 CFO/191 B (R3) IF900/60R 32 CFO/188B (R1)	Choice of low ground pressure radial flotation diamond tread 900/60 R32 or flotation lug tread VF 1050/50 R32 tires	
Hydraulic Requirements	Minimum 250 HP; 3 SCVs with standard 2320 psi (15996 kPa) system minimum	Minimum 250 HP; 3 SCVs with standard 2320 psi (15996 kPa) system minimum	
Tracks	Kinze Tracks by Camso 36" W; 100" ground contact length; 7,214 Total Footprint (sq.in.); (1) 31½" end wheels per track; (4) 13.77" mid wheels per track.		
Weight - Empty	14,640 lb (6640.5 kg)	Tires 15,100 lb (6849.2 kg)	Tracks 23,000 lb (10432.6 kg)
Hitch Weight - Empty	2500 lb (1134 kg)	2500 lb (1134 kg)	
Hitch Weight - Loaded	5000 lb (2268 kg)	5000 lb (2268 kg)	
Transport Width	13'-5" (4.08 M)	13'-5" (4.08 M)	
Width - Grain Tank	---	12'-4" (3.75 M)	
Length - Grain Tank	---	19'-3" (5.86 M)	
Height - Short Side	---	11'-7" (3.5 M)	
Height - High Side	---	12' 7" (3.8 M)	
Length - Overall	28'-4" (8.63 M)	30'-4" (9.24 M)	

\* Approximate with 15% moisture corn. Capacity and bushels/minute will vary with moisture content of grain and/or PTO RPM.

1. Read and understand instructions provided in this manual and warning labels. Review these instructions frequently!
  2. This machine is designed and built with your safety in mind. Do not make any alterations or changes to this machine. Any alteration to design or construction may create safety hazards.
  3. A large portion of farm accidents happen from fatigue or carelessness. Safe and careful operation of tractor and grain cart will help prevent accidents.
  4. Never allow cart to be operated by anyone unfamiliar with operation of all functions of the unit. Operators must read and thoroughly understand all instructions given in this manual before operating or working on equipment.
  5. Be aware of bystanders, particularly children! Always look around to make sure it is safe to start tow vehicle engine or move grain cart. This is particularly important with higher noise levels and quiet cabs, as you may not hear people shouting.
  6. Make sure cart weight does not exceed towing capacity of tractor, or bridge and road limits. This is critical to maintain safe control and prevent death or injury, or property and equipment damage.
  7. Never ride or allow others to ride on cart.
  8. Store cart in an area away from human activity. DO NOT permit children to play on or around stored unit.
  9. Keep hands, feet, and clothing away from moving parts. Do not wear loose-fitting clothing which may catch in moving parts.
  10. Always wear protective clothing, shoes, gloves, and hearing and eye protection applicable for the situation.
  11. Do not allow anyone to stand between tongue or hitch and towing vehicle when backing up to cart.
  13. Prevent electrocution, other injuries, or property and equipment damage. Watch for obstructions such as wires, tree limbs, etc. when operating machine. Be aware of clearances during turns and when folding/unfolding grain chute.
  14. Pick levellest possible route when transporting across fields.
  15. Never operate grain cart without PTO driveline guards, tractor master shield and implement shields in place. Make certain PTO driveline guards turn freely and are properly attached.
  16. Make sure parked machine is on a hard, level surface. Wheel chocks may be needed to prevent unit from rolling.
  17. Follow all federal, state/provincial and local regulations when towing farm equipment on a public highway. Use safety chain (not an elastic or nylon/plastic tow strap) to retain connection between towing and towed machines in the event of primary attaching system separation.
  18. Make sure all safety/warning lights, SMV sign, and reflective decals are in place and working properly before transporting machine on public roads.
  19. Maintain field drive speeds that are appropriate to the load condition and field condition.
  20. Reduce speed prior to turns to avoid the risk of overturning. Avoid sudden uphill turns on steep slopes. Always drive at a safe speed relative to local conditions and ensure your speed is slow enough for a safe emergency stop.
  21. Always keep the tractor in gear to provide engine braking when going downhill. Do not coast.
  22. Always disengage PTO, shutoff tractor engine and remove the ignition key before leaving tractor seat, lubricating or working on grain cart, or when cleaning out debris.
  23. Always make sure PTO connecting yokes are securely locked on tractor and implement shaft before operating cart.
  24. Be especially observant of the operating area and terrain. Watch for holes, rocks or other hidden hazards. Always inspect area before operation. DO NOT operate near edge of drop-offs or banks, or on steep slopes as overturn may result. Operate up and down (not across) intermediate slopes. Avoid sudden starts and stops. Be extra careful when working on inclines.
  25. Never step across any driveline. Do not attach drivelines with bolts or pins longer than recommended. Never operate cart with damaged PTO driveline guards.
  26. Disposing of waste improperly can threaten the enviroment. To dispose of your equipment properly contact your local environmental or recycling center.
- Never pour waste onto the ground, down a drain, or into any water source.
- When disposing of waste such as oil, use leakproof containers. Be sure to use containers that do not resemble food or beverage which may mislead someone into consuming them. Dispose of oil per your local, regional requirements.
- When disposing of any fertilizer chemicals used, contact the supplier of the chemicals.
- 851/1051 cart consists of 85% recyclable materias, 10% recyclable plastic and rubber, and 5% waste.

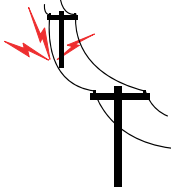

Following are some common hazard warnings associated with this equipment. Pay close attention to all safety, operating, and maintenance information in this manual and decals applied to your equipment.

	<p>Contacting or coming close to power lines or other high energy sources will cause death or serious injury.</p>
	<p>Keep away from power lines or high energy sources at all times.</p>

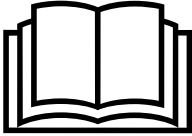
	<p>Loss of control can cause death or serious injury, or damage to property and equipment. Tow only with farm tractor weight rated and configured for this equipment. Use safety chains and transport as specified in the Operator and Parts Manual.</p>
	

	<p>Improperly operating or working on this equipment could result in death or serious injury. Read and follow all instructions in Operator Manual before operating or working on this equipment.</p>
	

	<p>Contact with rotating driveline will cause death or serious injury. Keep away at all times when operating.</p>
	<p>Never operate without all guards and equipment shields properly installed.</p>

	<p>Explosive separation of rim and tire parts can cause death or serious injury. Overinflation, rim and tire servicing, improper use of rims and tires, or worn or improperly maintained tires could result in a tire explosion.</p>
	

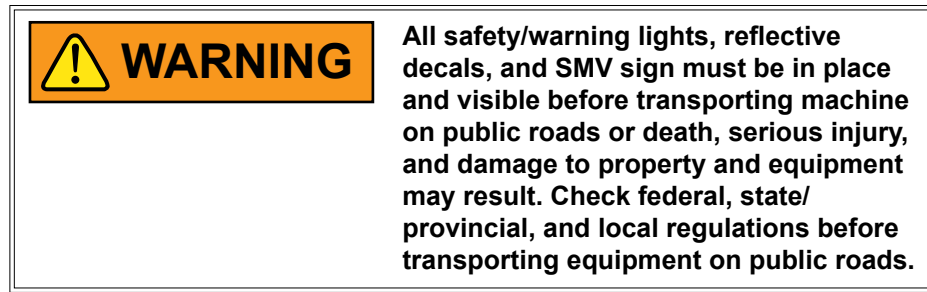

Safety signs and decals are placed on the machine to warn of hazards and provide important operating and maintenance instructions. Information on these signs are for your personal safety and the safety of those around you. FOLLOW ALL SAFETY INSTRUCTIONS!

- **Keep signs clean so they can be easily seen. Wash with soap and water or cleaning solution as required.**
- **Replace safety signs if damaged, painted over, or missing.**
- **Check reflective decals and SMV sign periodically. Replace if they show any loss of reflective properties.**
- **When replacing decals, clean machine surface thoroughly with soap and water or cleaning solution to remove all dirt and grease.**

**NOTE: Safety sign and decal locations are shown in the Parts Manual for this machine.**

**NOTE: Style and locations of SMV sign, reflective decals, and safety/warning lights conform to ANSI/ASABE S279.14 JUL 2008 and ANSI/ASABE S276.6 JAN 2005.**

**This page intentionally blank.**

**SHIPPING TIE DOWNS**

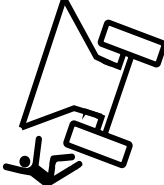
 <b>WARNING</b>	<b>SHIPPING TIE DOWN ONLY.</b>
	Pulling from this point can cause rollover or loss of control and result in death, serious injury, and damage to property and equipment.



**Frame Tie Downs**

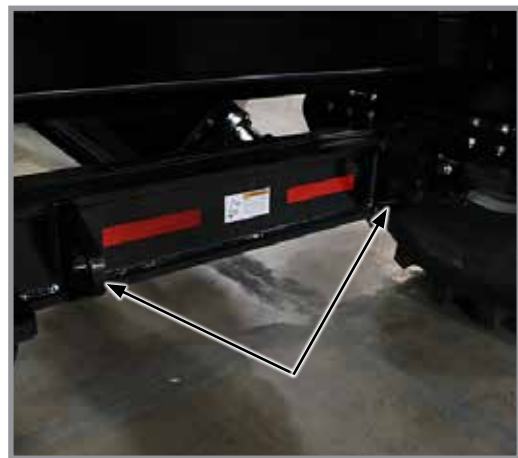

**Axle Tie Downs**

Tie downs are located on the frame and axle to aid in securing the grain cart to a shipping trailer.

**SHIPPING LOCATION**

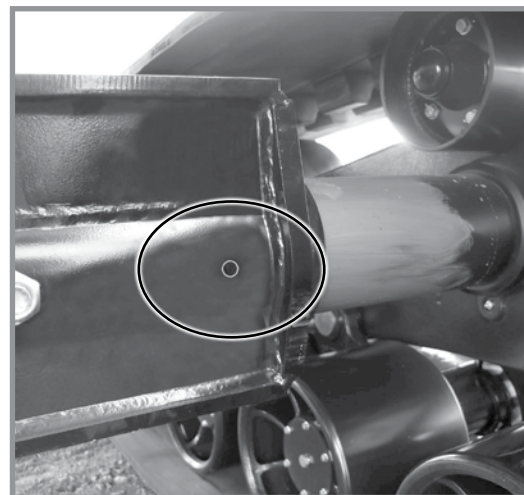
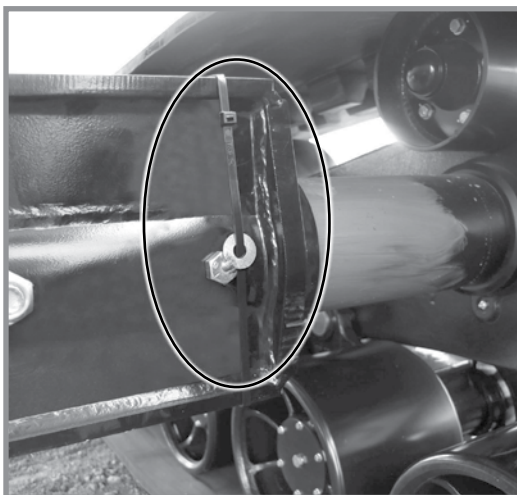

This location is used to extend track width for truck transport only. Do not operate cart with extended track width. Temporary pin is used to hold spindle in place. Discard pin after track is placed in operation position.

## MACHINE PREPARATION

Lubricate grain cart per lubrication information in this manual prior to initial operation and at prescribed intervals. Make sure all tires are properly inflated or track tension is properly adjusted before each use. Torque all wheel lug nuts to specified torque.

## TRACTOR REQUIREMENTS

Consult your dealer for information on horsepower requirements and tractor compatibility. Three SCV's are required for standard cab operation. A 12 volt DC electrical system is required on all sizes to operate safety/warning lights, work lights, optional electronic scale system, or optional electronic roll tarp.

## TRACTOR PREPARATION AND HOOKUP

1. Slide tractor drawbar in as far as possible, but still allows PTO shaft to have sufficient clearance to prevent damage to driveline components when making sharp turns and operating over uneven ground.

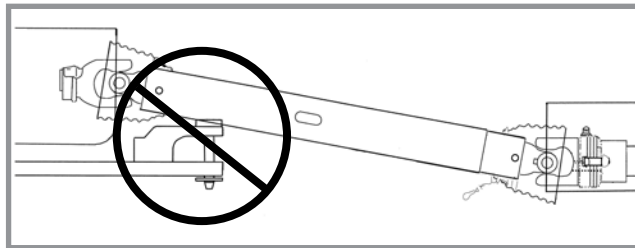

Avoid clevis hitch interference

### NOTICE

Clevis hitch (hammer strap style) drawbars may need to be removed to prevent damage to PTO assembly.

2. Position PTO as far right of hitch as possible until parking jack is stowed.



PTO shaft positioned for tractor hookup

### NOTICE

Adjust tractor drawbar to prevent severe bends in PTO U-joint angles and to allow sufficient clearance between tractor drawbar/hitch pin and PTO shaft.

3. Connect cart to tractor hitch. Use a high quality hitch pin of sufficient length and strength and secure pin with a locking device. Torque attaching hardware to 840 ft-lb (1138 Nm).



Jack stowed



Jack installed

**WARNING**

Parking on uneven or soft surfaces could cause death, serious injury and damage to property and equipment.

Park equipment on a hard, level surface. Wheel chocks may be needed to prevent unit from rolling.

**NOTICE**

Do not unhook cart while loaded.

4. Raise jack. Move jack to storage location.

**NOTICE**



Clean and grease PTO shaft coupling each time PTO is installed. Apply coating of high-speed industrial coupling grease, such as Chevron® Coupling Grease, that meets AGMA CG-1 and CG-2 standards to extend shaft spline life.

5. Attach cart PTO connecting yoke to tractor PTO shaft. Spring loaded yoke pin must engage groove in tractor PTO shaft. Slip tube grease fitting must be visible through hole of outer tube.



Safety chains

6. Transport safety chain must be used to ensure connection is retained between cart and tractor in the event of a hitch pin/drawbar failure.

 <b>WARNING</b>	<p>Pressurized hydraulic fluid can penetrate body tissue and result in death, serious infection, or other injuries. Fluid injected under skin must be <b>IMMEDIATELY</b> removed by a surgeon familiar with this type of injury. Make sure connections are tight and hoses and fittings are not damaged before applying system pressure. Leaks can be invisible. Keep away from suspected leaks. Relieve pressure before searching for leaks or performing any system maintenance.</p>
	

<b>NOTICE</b>	<p>Wipe hose ends to remove any dirt before connecting couplers to tractor parts or contamination may cause equipment failure.</p>
---------------	--

7. Connect hydraulic hoses to tractor. Kinze grain carts require 3 SCV's for operation.

Hydraulic Control Settings		
Control	Hose color	Function
SCV1	Red	Auger fold
SCV2	Yellow	Spout tilt
SCV3	White	Flow gate

8. Connect seven terminal breakaway connector for the lighting system on cart to seven pin connector on tractor. If your tractor is not equipped with SAE Standard 7 terminal connector, obtain through your local tractor supply dealer. Check clearance lights, signal lights, and auxiliary work lights for proper operation.
9. Connect optional electric roll tarp and camera harnesses. Check for proper operation.

## CART OPERATION

 **WARNING**

Contact with rotating driveline will cause death or serious injury. Keep away at all times when operating.

Never operate without all guards and equipment shields properly installed.

 **WARNING**

Towing loaded grain carts on public roads and bridges can result in death, serious injury, and damage to property and equipment.

Never tow a loaded grain cart on public roads and bridges.

 **WARNING**

Limited visibility can conceal people, animals, or objects and result in death, injury, and damage to property or equipment.

Check completely around cart before moving!

 **WARNING**

Wide loads or loads with a high center of gravity may cause instability or rollover when operating on hillsides or in rough terrain.

 **WARNING**

Do not transport cart with vertical auger extended. This can cause loss of control and could result in death, serious injury, or damage to property or equipment.

 **WARNING**

Falling from equipment can cause death or serious injury.

Use three points of contact when working on equipment.

Never ride on equipment!

 **WARNING**



Contact with hydraulic folding auger can cause death, serious injury, and damage to property and equipment. Stay away from folding auger at all times. Make sure auger is clear of people and objects before folding or unfolding.

 **WARNING**



Contacting rotating auger will cause death or serious injury. Never open or close cleanout door with auger operating.

Remove power source before working on equipment.

 **WARNING**



Moving auger can cause death or serious injury. Disable auger fold before climbing ladder.

 **DANGER**

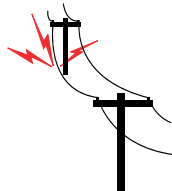

Contacting or coming close to power lines or other high energy sources will cause death or serious injury.

Keep away from power lines or high energy sources at all times.

 **DANGER**

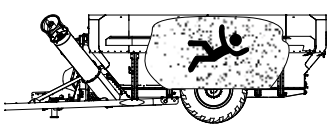

Entering the grain cart can result in death or serious injury.

- Never enter grain cart when there is an energy source attached to the cart.
- Flowing grain can trap and suffocate.



## UNLOAD GRAIN CART

### NOTICE



Operating tractor PTO above 750 RPM with augers empty will damage equipment.

Make sure grain is flowing properly before increasing to higher RPM's. Read Operator's Manual for instructions.

### NOTICE

Roll tarp must be completely open during loading and unloading operations or suction will damage equipment.



### DANGER

Never work around PTO or gearbox drive system or allow anyone else to do so while PTO is running.

1. Open roll tarp completely. Refer to [“Manual and Electric Roll Tarp” on page 2-13.](#)
2. Unfold vertical auger.
3. Engage PTO at low tractor RPM.
4. Start to open flow gate and increase tractor RPM. An indicator on front panel shows position of flow gate.
5. Set grain flow gate and tractor RPM to desired level.
6. Adjust tip spout. Slow tractor RPM as cart reaches empty.
7. Close flow gate.
8. Allow vertical auger to clean out and disengage PTO.
9. Fold auger to storage position.



Flow Gate Position Indicator



### WARNING

Do not transport cart with vertical auger extended. This can cause loss of control and could result in death, serious injury, or damage to property or equipment.

---

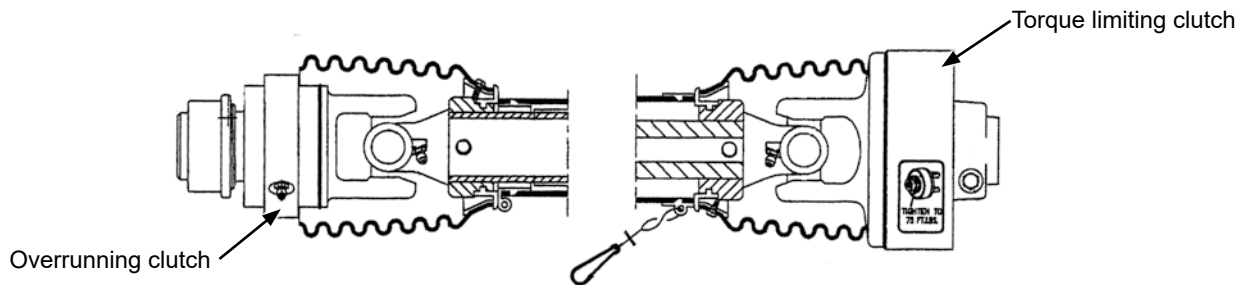
**PTO TORQUE LIMITING/OVERRUNNING CLUTCH PROTECTION**

The torque limiting clutch disengages if auger becomes obstructed to prevent driveline and gearbox damage. The torque limiting clutch resets automatically when PTO RPM is reduced.

The overrunning clutch allows auger system to freewheel and protects tractor and cart from shock damage with PTO brake-equipped tractors.

**AUGER CLEANOUT DOOR**



**DANGER**

Never open inspection cover while PTO and/or augers are running.



**WARNING**

Contacting rotating auger will cause death or serious injury. Never open or close cleanout door with auger operating.



Remove power source before working on equipment.

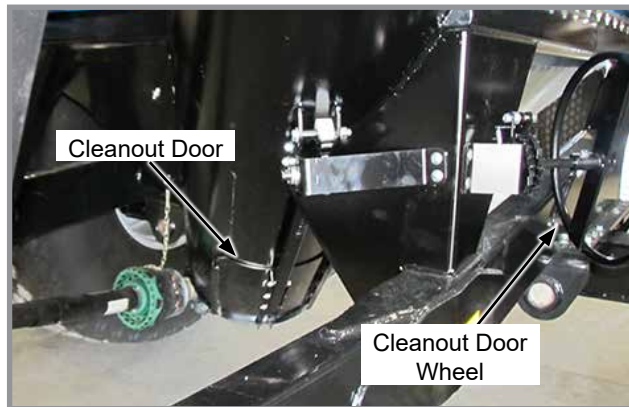

Grain Carts are equipped with a cleanout door at the bottom of the vertical auger.

The cleanout door may be opened when total cleanout of the wagon is required, such as when changing crops, to preserve grain identity, or in preparation for storage.

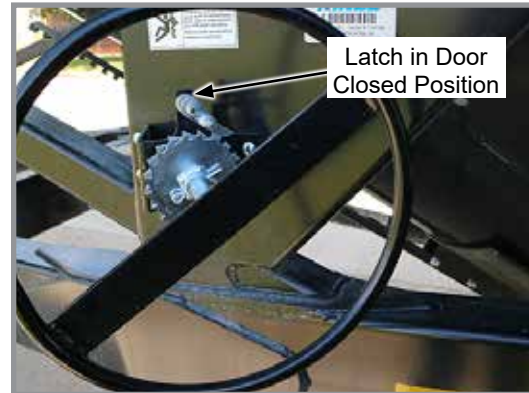

**To open cleanout door:**

1. Push latch on cleanout door wheel towards tractor.
2. Rotate wheel counterclockwise to open door.

**To close cleanout door:**

1. Push latch on cleanout door wheel away from tractor.
2. Rotate wheel clockwise to close door.

At the end of each season or after extended use, the cleanout door should be opened and the auger chamber cleaned of all debris and accumulated grain to prevent rust and mold.

Fully close cleanout door after cleanout is complete.

## VERTICAL AUGER WORK LIGHT

Work lights are mounted in a fixed location on the vertical auger and inside the grain cart, and cannot be moved. Limited adjustments can be made by swiveling light on its base.

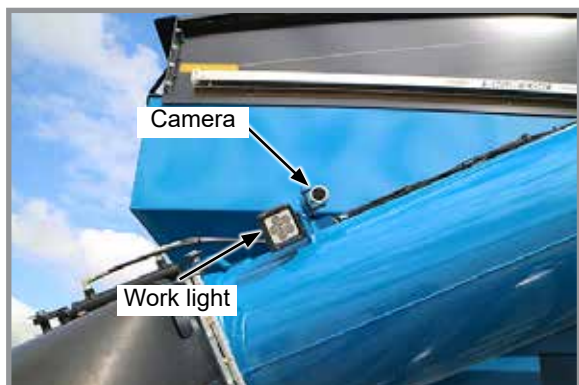

Vertical Auger

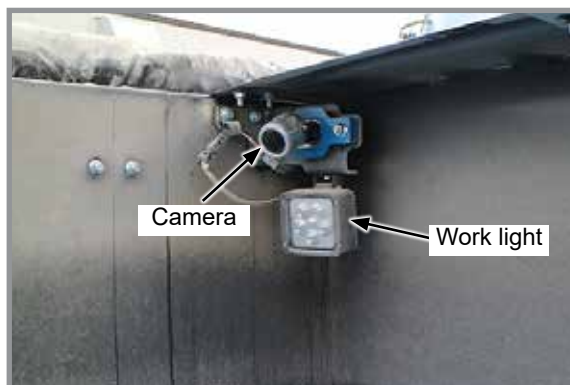

Inside Cart



Rear of Cart

## CAMERAS



**WARNING**

Contact with moving grain cart can cause death, serious injury, and damage to property or equipment. Camera coverage areas are limited. **DO NOT** rely on cameras to determine if the area around the cart is clear. Cameras are an aid to unloading and maneuvering only.

For the optional camera kit, cameras are mounted on the vertical auger below the work light and on the rear of the cart as shown above. The additional 2-camera kit is also available with one camera mounted inside the grain tub in the corner and the second installed in a location chosen by the operator.

**NOTE:** Refer to the operator's manual provided with camera.

## MANUAL AND ELECTRIC ROLL TARP

### NOTICE

Roll tarp must be completely open during loading and unloading operations or suction will damage equipment.

### NOTICE

To prevent excess wear or damage: Keep tarp at 40-60 lb (18-27 kg) tension. Do not walk or stand on end caps. Open tarp system and secure roll tube to wagon for speeds of 30 mph (48 kph) or higher.

### For Manual Tarp:

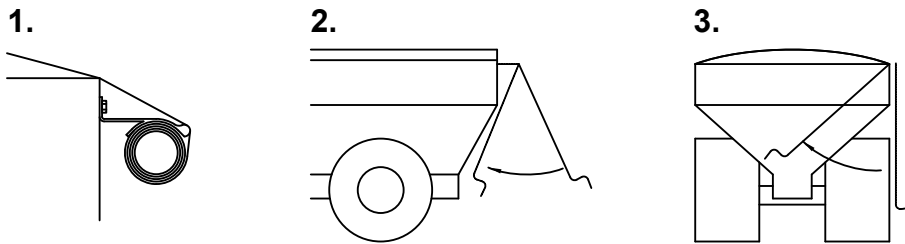

#### To Open:

1. Lift crank out of retainer.
2. Rotate crank counterclockwise until tub is open and tarp is rolled up against the stops.
3. Lift crank back into retainer.

#### To Close:

1. Lift crank out of retainer.
2. Rotate crank clockwise over the tub and up under the rest plate.
3. Bring crank down toward the rear of the cart.
4. Lift crank back into retainer, making sure not to overtension the tarp.

#### To Adjust Tension:

1. Roll tarp down from latch plate.
2. Remove crank from shaft.
3. Rotate crank one or two teeth and reassemble.

**For Electric Tarp:**

**NOTE: Mount the circuit breaker as close to the power source as possible. Direct connection to the battery or a primary battery-direct power buss is advised. Run 6ga minimum wire size to the tarp system connector plug.**

Electric Roll Tarp can be operated with remote or manual switches.

Close Tarp: Push switch to **CLOSE** and hold. Observe tarp and release switch when tarp has fully closed and rolled tightly under rest plate.

Open Tarp: Push switch to **OPEN** and hold. Observe tarp and release switch when tarp has fully opened and rests against the tarp rests.

**Power-up/down:**

The transmitter will power up when the lid is opened. The transmitter will power down when the lid is closed or when the lid is left open three minutes after the last button is pushed.

**Standard operation:**

After power-up, the first channel will be immediately active and the LED indicator for this channel will be flashing. The *Open/On* and *Close/Off* buttons are operational for the indicated active channel. While pressed, the LED indicator will flash faster, indicating channel operation.

The *Select* button will cycle between enabled channels. If only one channel is enabled, there will be no apparent change when the Select button is pressed.

**ROLL TARP REMOTE CONTROL TROUBLESHOOTING**

<b>PROBLEM</b>	<b>SOLUTION</b>
No lights on remote when lid is open.	Close lid for three seconds, then reopen lid.
	Make sure there are no magnets close to the transmitter.
	Open transmitter case and make sure battery is placed correctly in the remote.
	Remove battery and bend contacts closer together. Put battery back in and try again.
	The battery may be dead and must be replaced. Replacement quantity is 2 "AAA" batteries.
	SMART1+ is damaged and must be replaced.
System not operable with remote.	Make sure remote is set to the right channel. If you cannot set remote to the desired channel, it must be reprogrammed (see transmitter programming instructions).
	Make sure no other transmitters are being used near your system.
	Determine if the transmitter is the problem by testing it with a different receiver or by using a second remote. If receiver was the problem, reprogram receiver (see the receiver programming instructions). If this doesn't work, receiver should be replaced.
	Make sure you are within a couple feet of the receiver and try again. If transmitter works at short range but not at greater distances, you have a range problem, so a new battery may be needed. If the remote battery is not the cause, call the Help Line.
The SMART1+ channel light is blinking, but when I press the Open/On or Close/Off button, the light goes out or just continues to blink at the same speed.	Remove battery and bend contacts closer together. Put battery back in and try again.
	The battery may be dead and must be replaced. Replacement quantity is 2 "AAA" batteries.
	SMART1+ is damaged and must be replaced.

## TRACK SYSTEM COMPONENTS

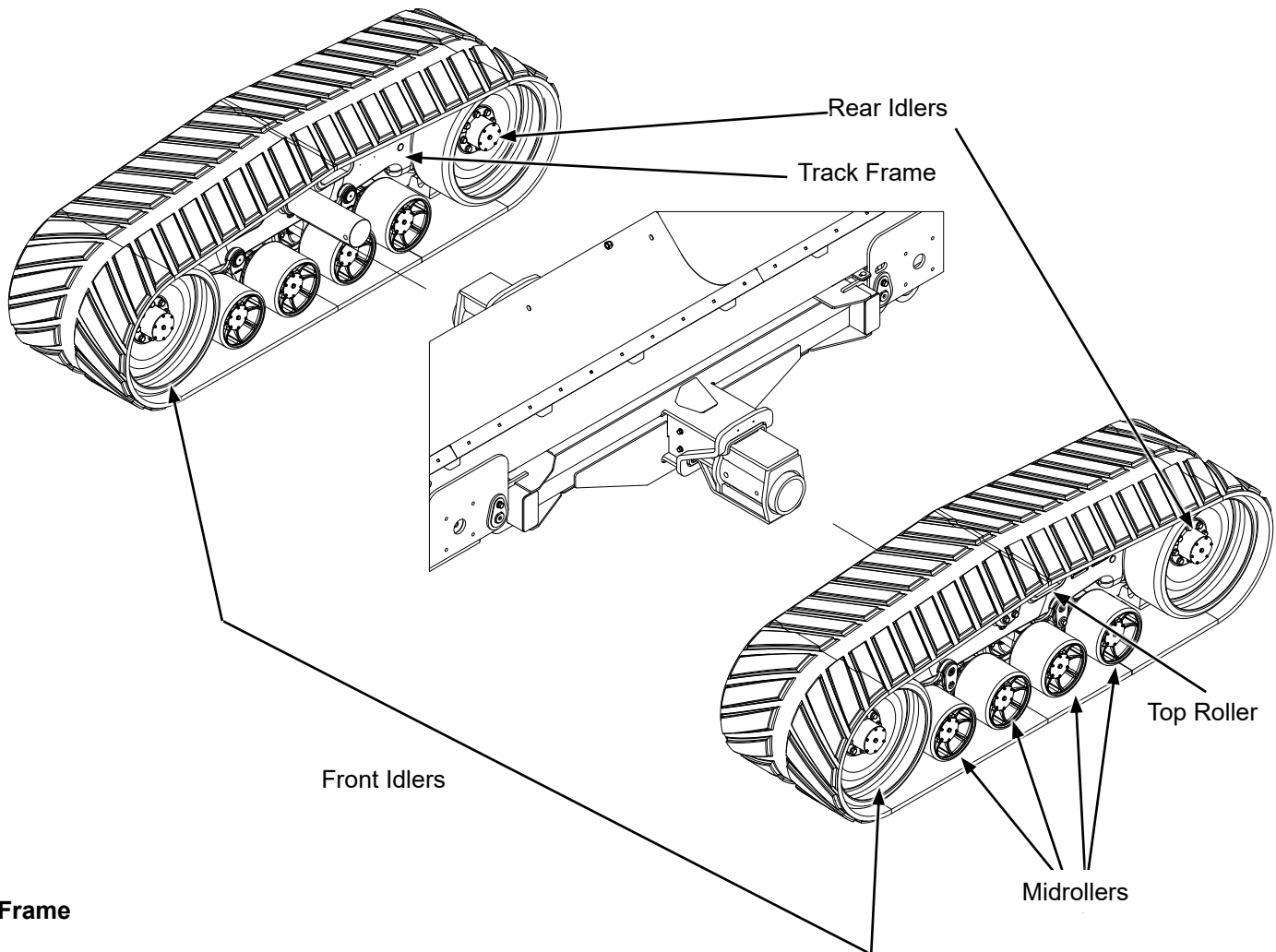

### Frame

#### Camso

The main frame consists of a casting, and the front alignment yoke and rear tension link are cast members.

#### TDS

The main frame consists of a weldment. The front alignment housing and rear tension pivot arm are weldments.

### Axles

#### Camso

Front and rear axles are machined from the yoke castings, allowing for dimensional stability and few moving parts. They feature oil bath hubs mounted on tapered bearings and mechanical seals for extreme working conditions. Each hub has its own oil reservoir with access port for maintenance and checking oil levels. Refer to Lubrication and Maintenance section for oil fill and greasing information.

#### TDS

Front and rear axles are welded into the tension pivot arm and alignment housing, allowing for dimensional stability and few moving parts. They feature oil bath hubs mounted on tapered bearings with mechanical seals for extreme working conditions. Each hub has its own oil reservoir with access port for maintenance and a sight glass for checking oil levels. Refer to Lubrication and Maintenance section for oil fill and greasing information.

### Idlers and Midrollers

The idlers have the function of guiding the rubber track by acting on the lateral surfaces of the guide lugs. Rotation of belts is recommended to extend life.

## Tensioning System

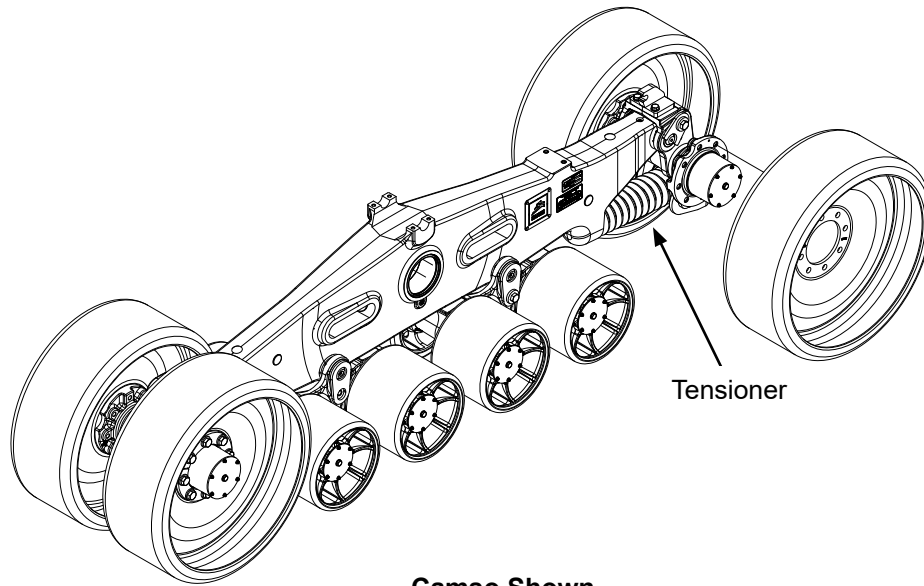

**Camso Shown**

The tensioning system is located between the 2 rear idlers. The tension force is provided by a mechanical spring mechanism. Track tension is provided by the spring and does not need adjustment during operating and changing field conditions. Provisions are made to compress the spring allowing for removal of idlers and track assemblies during maintenance and servicing. Special tools are available from Kinze to compress the spring and detension the tracks.

## Rubber Tracks

Rubber tracks are manufactured with high quality rubber and high strength steel cabling inside. The tread layout ensures good flotation, excellent life, and self-cleaning characteristics.

## TRACK TRANSPORT SPEEDS

Model	Operating Condition	Transport Speed (Maximum)	Transport Duration (Maximum)
1121	Empty	25 mph (40 kph)	30 minutes

**NOTE: Track carts should be limited to road use only when empty.**

If additional distances are required, a 30 minute cool down period is recommended before transport is resumed. Absolute speed and duration levels may vary, depending on system type and ambient conditions. Recommended speed and duration information help avoid system heat buildup that could cause reduction in track life.

## TRACK SYSTEM MINIMUM TURNING RADIUS LIMITATIONS

On either field or road, the minimum turning radius is 3 times the overall length of the tractor plus the implement.

Track systems operate best when running straight or in gentle turns. If a track system is pivot or spot-turned, the opportunity exists for soil and dirt to be ingested into the system. Even though the track system has a tension recoil system, if that tension recoil is exceeded, high loads in the frame and track can be generated which may cause track or system damage.

### **NOTICE**

**Minimum turning radius limits should be strictly observed to avoid damage to track system.**

## TRACK SYSTEM BREAK-IN PROCEDURES

Guide lug wear is reduced when correct break-in procedures are followed. During the break-in period, rolling components undergo a polishing-in process to achieve a smooth steel to rubber interface with the guide lug. Rubber uses dust and dirt as a dry lubricant during break-in and operation to minimize heat and reduce rubber stickiness. New tracks should be exposed to dry and dusty soil conditions as soon as possible. Operation without dust or soil in the system, especially during high speed roading, generates high levels of damaging heat. If roading must be done, a dry lubricant such as soil, talc, graphite, oil dry should be applied to the guide lugs periodically during roading until field operation resumes.

---

## TRACK SYSTEM OPERATIONAL GUIDELINES

- Any application differing from the ones prescribed in this manual is to be considered improper and potentially dangerous.
- Correct track tension is required for best performance and track life.
- Track system can work in extreme conditions: for operator and machine safety, be sure to know your surroundings.
- Track system is free to pivot around the main axle following ground conformation.
- During transition over uneven ground terrain, check for interferences and move slowly to avoid over-oscillating the undercarriage.
- Overall width and height of machine/equipment with track system could differ from the original width and height with tires. Be sure to know actual machine height and width as well as width restrictions prior to operation.
- Cross large ground irregularities with suitable speed reduction and/or proper incidence angle. In particular, when high, sharp bumps are crossed move forward slowly to avoid shocks on the machine.
- The track system does not damage standard road-bed constructions. Operators must know and respect road traffic laws.

Rubber tracks have not been designed for extended use on the road. Kinze is not responsible for track and system damage resulting for extended road use. Long road periods and/or roading at higher than recommended maximum speeds may cause premature wear or failure of the track or wheels. To reduce damage during roading, decrease overall machine weight and decrease machine speed, refer to [“Track Transport Speeds” on page 2-17](#) for further information.

- Long runs on side slopes increase the wear on the side of guide lugs and idlers.
- Keep material out of the undercarriage. Inspect undercarriage daily and remove any material as necessary. In some conditions inspect more frequently.
- If a machine becomes stuck, clear away as much material from the undercarriage as possible prior to pulling the machine out.
- Avoid short turning radius turns and operation(s) especially when loaded. Spot turning creates debris ingestion and can also induce high torque loading in the system.
- Configure drawbar and hitch correctly during field operation(s).
- Use caution when operating track systems in loose, flowing material. Loose material can become trapped between track and idlers, resulting in track damage.
- Keep material out of the undercarriage. This may require scraping material out of tight places and in some conditions require frequent inspection and cleaning.

## ELECTRONIC SCALE - GT 400

Electronic scale option includes four axle weigh beams, one hitch weigh beam, a tractor-mounted scale indicator console and cables, brackets, and mounting hardware.

To measure what is unloaded, press “START/STOP UNLOAD” before starting to unload. When finished, press STOP.

To measure what is loaded (For example when doing a field yield check.), press “ZERO” to zero cart weight before loading.

**NOTE: Scale is most accurate when cart is sitting still on level ground when weighing.**



GT 400 Indicator

### Suggested Operating Procedures

**NOTE: Movement of cart causes scale indicator reading to fluctuate.**

**Step 1** Press  to turn on scale.

**NOTE: Allow one (1) minute for scale to warm up (allow 5-10 minutes in cold weather).**

**Step 2** Press and hold  to zero balance.

**NOTE: Zero balance indicator when empty at least once a day or more as required. If zero balance is not correct it only affects gross weight reading, not accuracy of displayed net weight.**

**Step 3** Load cart.

**Step 4** Press  to begin unloading.

Display reads zero. Arrows point to Net and Unload.

**Step 5** Unload cart. Negative reading on scale indicator is pounds unloaded.

**Step 6** Press  when unloading is complete.

Indicator displays remaining weight left on scale. Data is automatically added to accumulator and saved to Printer or DDL (data downloader kit).

**Repeat Steps 4 - 6 each time cart is unloaded.**

### Entering Field ID

A user-entered, 6 character identification number is used for referencing fields, trucks, owners or other information.

**Step 1** Press .

FIELD displays and a flashing cursor or character displays in the first position.

**Step 2** Press  to scroll available characters.

Hold for 4 seconds to increase scroll rate.

**Step 3** Press  to scroll back.

Press  to move to next character.

**Step 4** Press  to accept and save.

Refer to GT 400 manual provided and Troubleshooting Section of this manual for additional information.

### Scale Setup and Calibration Numbers

Setup Number: 127070  
Calibration Number: 41250

## GT 560 Operation

**NOTE:** Indicator must be on active screen before loading or unloading.

### Suggested Operating Procedures - With AutoLog

**NOTE:** Movement of cart causes scale indicator reading to fluctuate.

**Step 1** Press .

**Step 2** Press and hold  for two seconds to zero balance the GT 560 indicator if the container is empty. Active screen is displayed.

**NOTE:** To operate GT 560 with AutoLog, the GT 560 must be connected to a PTO or switch sensor and AutoLog must be turned ON.

**Step 3** Press .

**Step 4** Press  and  to select field name.

**Step 5** Press  to select required field name.

**Step 6** Press  to select required ID.

**NOTE:** Make sure active screen displays.

**Step 7** If AutoLog is enabled, start the PTO or open the discharge door. The GT 560 will display zero and enter the net mode.

**Step 8** Unload grain. Upper Display shows amount unloaded. Gross value (total amount left on cart) displays on second line of Lower Display.

**Step 9** If AutoLog is enabled, stop the PTO or close the door. The data record will be stored in memory of indicator. The data record screen will display the last data record for 10 seconds, then return to active screen.

**Refer to GT 560 manual for additional information.**

### Scale Setup and Calibration Numbers

Setup Number: 127070

Calibration Number: 41250

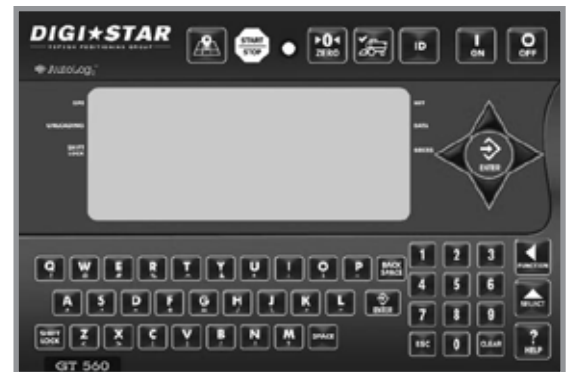

GT 560 Indicator

### Suggested Operating Procedures - Without AutoLog

**NOTE:** Movement of cart causes scale indicator reading to fluctuate.

**Step 1** Press .

**Step 2** Press and hold  for two seconds to zero balance the GT 560 indicator if the container is empty. Active screen is displayed.

**NOTE:** To operate GT 560 without AutoLog, the AutoLog feature must be turned OFF.

**Step 3** Press .

**Step 4** Press  and  to select field name.

**Step 5** Press  to select required field name.

**Step 6** Press  to select required ID.

**NOTE:** Make sure active screen displays.

**Step 7** Press  before unloading grain from container. The GT 560 will display zero and enter the net mode.

**Step 8** Unload grain. Upper Display shows amount unloaded. Gross value (total amount left on cart) displays on second line of Lower Display.

**Step 9** When unloading is complete, the data record will be stored in memory of indicator. The data record screen will display the last data record for 10 seconds, then return to active screen.

**Step 10** Press  when finished unloading grain. Refer to GT 560 manual for additional information.

**This page intentionally blank.**

## SCALE-TEC POINT

Electronic scale option includes two load cells, one hitch weigh beam, a tractor-mounted scale indicator console and cables, brackets, and mounting hardware.

To measure what is unloaded, press “START/PAUSE” before starting to unload. Weight being unloaded displays as a negative value. Record this information and press “STOP” to return to gross weight.

To measure what is loaded (For example when doing a field yield check.), press “ZERO” to zero cart weight before loading.

**NOTE: Scale is most accurate when cart is sitting still on level ground when weighing.**

**NOTE: POINT Mobile app and internet connectivity to Android or iOS device is required for initial set up. However, internet service (cellular data/WiFi) is not needed to function in the field.**



### Scale-Tec POINT Mobile App

1. Download and install the Scale-Tec Mobile app.

2. Create an account.

Android: See [“Getting Started: Creating a POINT Account \(Android\)”](#)

iOS: See [“Getting Started: Creating a POINT Account \(iOS\)”](#)

3. Register and Setup your device.

Android: See [“Getting Started: Registering and Setup of Your POINT Device \(Android\)”](#).

iOS: See [“Getting Started: Registering and Setup of Your POINT Device \(iOS\)”](#).



## Operating Procedures

**Step 1.** Press On/Off button to turn on monitor.

**Step 2. Zero Scale**

Display: Press and hold Zero button three seconds.

App: Press Zero.

**NOTE: To operate POINT with PTO sensing/ISOBUS, it must be connected to a PTO or switch sensor.**

**Step 3.** Load cart.

**Step 4. Begin unloading.**

If operating without PTO sensor or ISOBUS cable, press “START/PAUSE” before unloading and “STOP” after unloading is complete.

**Step 5. Unload cart.**

Negative reading on scale indicator is pounds unloaded.

**Step 6. Unloading complete.**

Press Stop button when unloading is complete.

**NOTE: Indicator displays remaining weight left on scale.**

Repeat Steps 4-6 each time cart is unloaded.

Refer to Scale-Tec’s knowledge base at [www.scale-tec.com](http://www.scale-tec.com) for user guides, FAQs, and online support.

See troubleshooting section of this manual for additional information:

[“POINT ISOBUS Troubleshooting” on page 2-33](#)

[“Enable ISOBUS PTO and GPS Detection For Use With REAP” on page 2-35](#)

## GRAIN MOISTURE SENSOR

Refer to the Digi-Star manual provided with your machine for complete information on optional features.





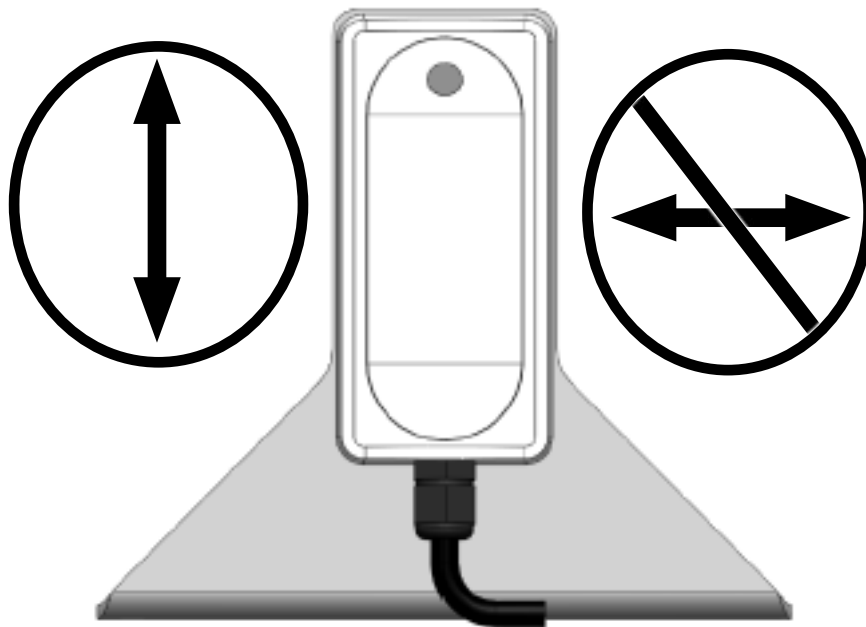



### General Guidelines

- Make sure sensor is mounted in a location where grain flow is consistent while unloading, such as above the unload door.
- Grain must flow across the sensor in the first few seconds during unloading, and grain flow must continue for at least 50% of the unloading period.
- If grain flow stops flowing over sensor during unloading, the scale will automatically stop recording moisture.
- Sensor only reads grain flow along the vertical length of the sensor, as shown below, and not across the sensor.



---

## GRAIN MOISTURE SENSOR TESTING







1. Verify all cables are connected and GT 560 is turned ON.
2. GT 560 GRAIN type should be set to CORN.
3. Test Moisture Sensor operation:
  - a. If Wi-Fi and smartphone Harvest Tracker App are installed:
    - i. Verify App is displaying weight on phone or tablet.
    - ii. Go to Moisture Sensor, so that sensor face is within reach.
    - iii. On App, access keypad function and type "6802" and press . This displays a rough moisture value, usually around 11%. This does NOT read actual grain moisture, and is only for system diagnostics.
    - iv. Place palm of bare hand on sensor face. Value will increase to approximately 25-35%.
    - v. Press  key on App to exit.
    - vi. Type in "6803" and press . This displays the temperature of the sensor in degrees F, which should be within 10 degrees of air temperature.
    - vii. Press  to exit.
    - viii. Sensor and cabling is operational if these tests are passed.
  - b. If Wi-Fi is not installed:
    - i. Find a second person to help you.
    - ii. Have one person in tractor cab, and the other within reach of the sensor.
    - iii. On GT 560, type "6802" and press . This displays a rough moisture value, usually around 11%. This does NOT read actual grain moisture, and is only for system diagnostics.
    - iv. Place palm of bare hand on sensor face. Value will increase to approximately 25-35%.
    - v. Press  on GT 560 to exit.
    - vi. Type in "6803" and press . This displays the temperature of the sensor in F, which should be within 10 degrees of air temperature.
    - vii. Press  to exit.
    - viii. Sensor and cabling are operational if these tests pass.
4. Run a couple of loads to calibrate sensor; refer to Moisture Sensor Calibration on next page

## GRAIN MOISTURE SENSOR CALIBRATION

The GT 560 Indicator and Moisture Sensor can be calibrated to a reference moisture, such as an elevator, hand held tester, or the combine. There are two ways to adjust the moisture percentage calibration as outlined on the following pages.

### ON-THE-FLY QUICK CALIBRATION

This is the quick method for calibrating the moisture percentage when setting up each GRAIN type, based on the combine's moisture reading. Grain must be flowing over the sensor while unloading the cart in AutoLog mode to perform this calibration. For the most accurate results and fine tuning, see Elevator Calibration section on the next page. Each GRAIN type should be calibrated when that grain is harvested, such as when changing from CORN to SOY.

1. Harvest grain as normal and transfer grain from combine into the grain cart until the cart is at least half full.
2. Keep track of the combine's average moisture percentage for the harvested load.
3. Select GRAIN type on GT 560 (press  then  use  &  arrows, and press  x4).
4. Begin unloading grain at normal speed. AutoLog will start on GT 560.
5. On main screen in center, observe the moisture percentage. See diagram below.
6. Press  or  arrow keys to adjust moisture up or down. Grain must be unloading from the cart and passing by the Sensor for this step to work.
7. Finish load as normal.

**NOTE: Moisture reading will likely stop before end of load. This is normal.**

8. Run a second load and verify moisture percentage is close. Perform Elevator Calibration steps on next page to achieve greater accuracy.

**NOTE: If moisture percentage is very inconsistent or does not appear to stay calibrated, the sensor may need to be repositioned. Readings that change unexpectedly or by large amounts while unloading is a symptom of poor grain flow past the sensor.**

9. Repeat calibration steps for other GRAIN types.

## ELECTRONIC SCALE PRINTING OPTIONS

Three printing options are available for use with the electronic scale with print-ready indicator console:

1. Printer connected directly to the indicator console.
2. (GT 560 ONLY) USB Flash Drive to transfer data between indicator and PC with Windows Operating System.
3. Data Downloader Kit which stores information in a downloader module for remote printing using any computer and printer with Windows 98/2000/XP/Vista operating systems. Module stores up to 1600 lines (64K bytes) of load data.

These printing options allow recording of load ID number, time, date, and weight.

### PRINTER OPTION

A power and data cable is included with printer.

See User's Manual supplied with printer for additional information.



### DATA DOWNLOADER (DDL) OPTION

The Data Downloader Kit option includes:

1. Module cable to connect indicator to downloader module.
2. Interface cable to connect downloader module to computer serial "com" port.
3. Downloader module which plugs into memory converter cable to store information and into interface cable to print information.
4. Program CD.

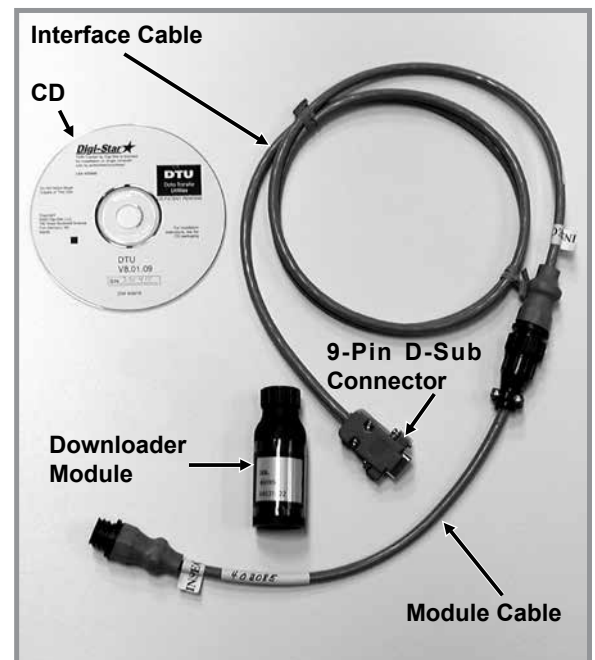

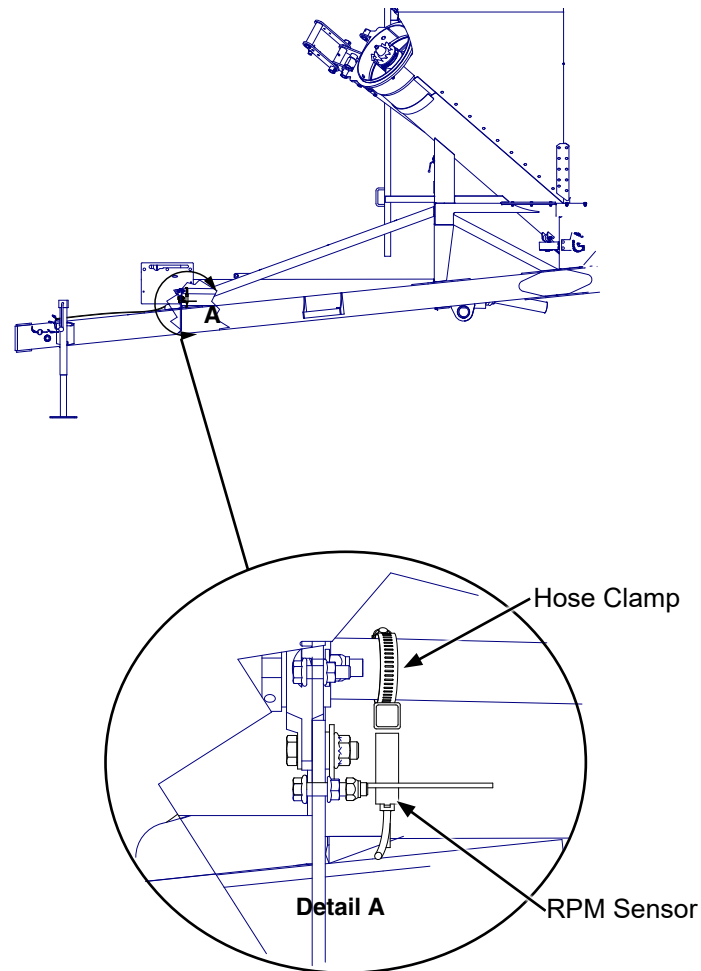
**ELECTRONIC SCALE - GT 560 AUTOLOG**

The GT 560 indicator has many features but it also boasts simple handsoff operation using a RPM sensor on the PTO shaft to trigger the start of the unloading process and the end of the unloading process. AutoLog prevents operator mistakes that could cause you to lose data on loads because the operator “Forgot” to push the “Start/Stop” key. You can still use “Start/Stop” key before unloading and again after unloading in case the sensor is damaged or not functioning for any reason. Weight, date, time, and additional information is stored automatically after each load is completed.

See GT 560 AutoLog Operators Manual provided and Troubleshooting Section of this manual for additional information.

The Data Downloader (DDL) stores and transfers data between indicator and a computer.

System requirements:

- Windows 98/2000/XP/Vista Operating System
- Serial Port
- 32 Mb of RAM
- Pentium 100 PC Or Higher
- 100 Mb Of Free Disk
- CD-Rom Drive

**Step 1.** Insert Data Transfer Utilities software (DTU) into CD-Rom.

**Step 2.** Connect interface and module cables.

**Step 3.** Connect interface cable (9-pin D-sub connector) to serial port on your computer.

**NOTE: Cable must be securely connected to a COM port to function.**

**Step 4.** Connect module cable to “Serial/J904” port on indicator. Press “PRINT” key. When printing is complete remove module cable only.

**Step 5.** Fasten downloader module to interface cable.

**NOTE: To lock downloader module to interface cable, twist fastener on downloader module.**

**Step 6.** Follow DTU software instructions to transfer data files to a Microsoft Excel spreadsheet (or comparable program):

**Step 7.** Save scale output to a text file (instructions included with DTU software).

**Step 8.** With Microsoft Excel open (a) Select “Data” file menu, select “Import External Data”, then “Import Data”. (b) Select text file to be transferred. (c) Text import wizard displays. (d) In original data type section select “delimited” and click NEXT button. (e) In delimiters section select SPACE check box and click NEXT button. (f) Click FINISH.

**Step 9.** Import to “Existing Worksheet” or “New Worksheet” and click OK.

**Step 10.** Text file now appears in separate cells and columns.

## PRINT ACCUMULATOR

This option stores an accumulated value in a memory location called "PRTACC". Each time a "PRINT" command is executed, the weight value on the display is added to the "PRTACC" value.

Three print formats are available:

"PRTAC1" and "PRTAC2" print formats include:

- Scale ID
- Weight
- Weight Tag (Net, Gross, Load/Unload)
- Accumulated Weight
- Print Accumulator Tag
- Date and Time

**NOTE: "PRTAC1" displays data on one line and "PRTAC2" displays data on two lines.**

"PRTAC3" includes Unit of Measure and Lock-On Status in addition to features listed above and displays data on one line.

### Suggested Operation Procedures

**Step 1.** Press and hold "NET/GROSS" for 3 seconds.

**NOTE: "SCALID" is displayed followed by current ID.**

**Step 2.** Use left arrow (PRINT/TARE) and up arrow (NET/GROSS) keys to enter a new Scale ID.

**Step 3.** Press "ON" to view accumulated data.

**NOTE: Press "ZERO" to clear total when accumulated weight is displayed.**

**Step 4.** Press "ON" to resume weighing.

**Step 5.** Press and hold "PRINT/TARE" for 3 seconds to send data from serial port and store accumulated data.

**ELECTRONIC SCALE TROUBLESHOOTING**

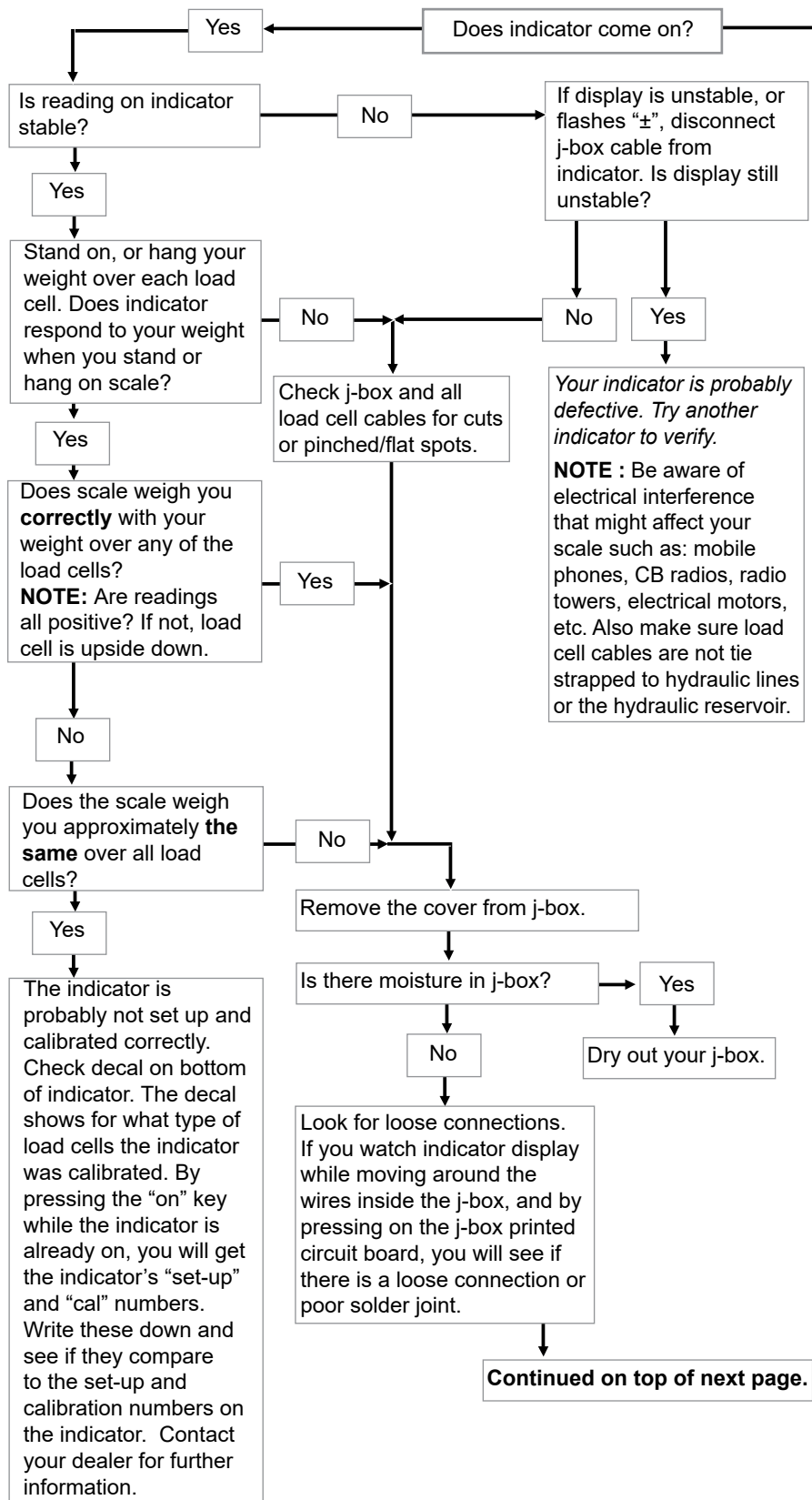

**Defective Indicator:** If you suspect a bad indicator, the easiest way to check is to try another indicator. Even if indicator is a different model, or is set-up for a different scale, it at least should come on.

**Poor Connection:** Poor connections can be tricky. If in doubt, don't just tighten connection, take them apart and clean them first. Any connection with rust or paint should be sanded or wire brushed.

**Weak Battery:** If you suspect battery, try replacing it with another one. Don't be fooled if using a voltmeter to test your battery. A weak battery may test good if checked when there is no load on the battery.

**Defective Power Cord:** Make sure the power cord's red wire is connected to the plus (+) positive side of battery, and the black (-) negative wire is connected to the negative side of battery. If using a multimeter to check for voltage, measure between pin 1 (pos) and pin 2 (neg). The meter should read between 10.5 and 14.5 volts DC. If using a tractor power cord, the black wire on the tractor power cord is positive and the white wire is negative.

### ELECTRONIC SCALE TROUBLESHOOTING

Continued from bottom of previous page.

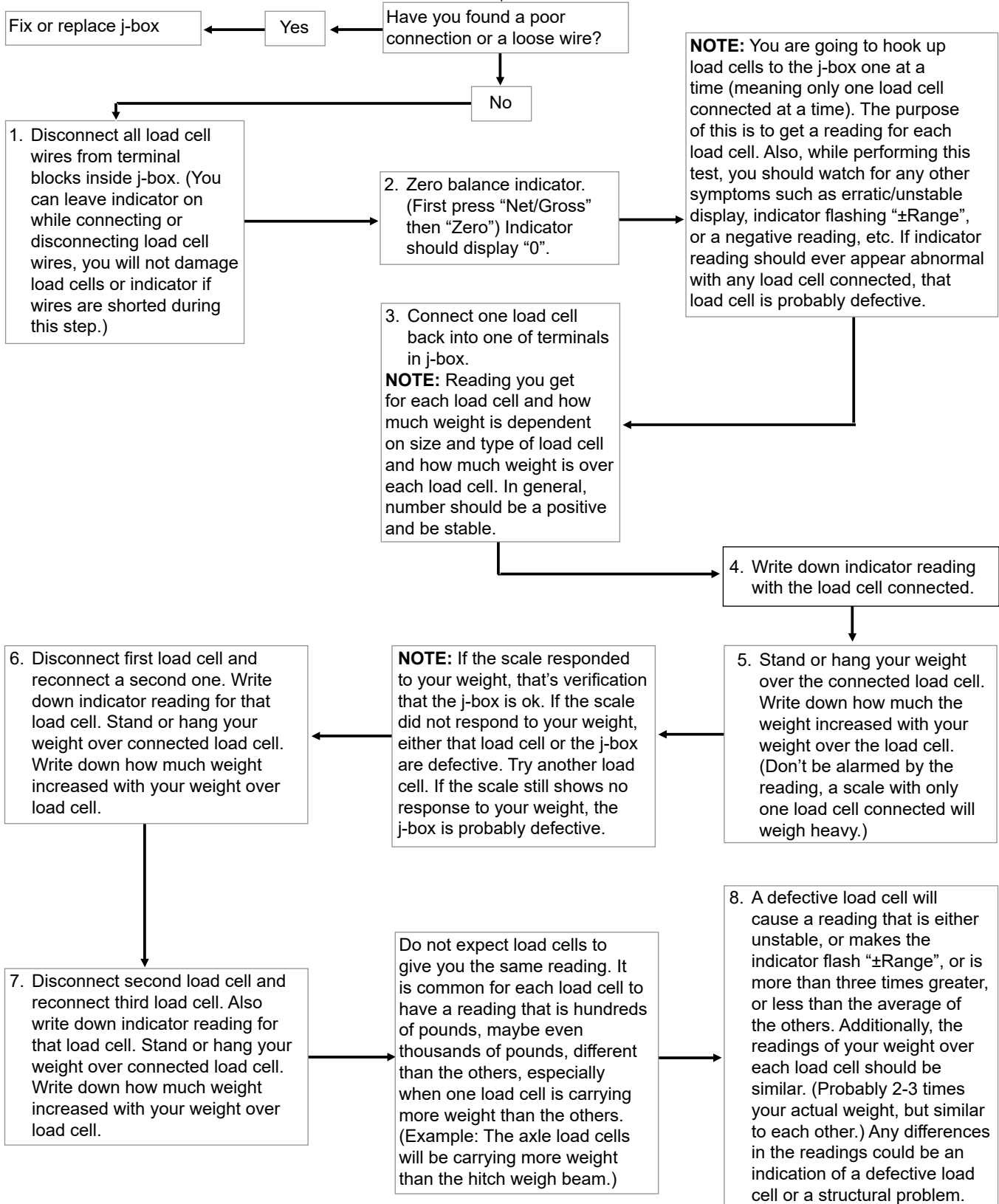

**POINT ISOBUS TROUBLESHOOTING**

<p>1. Check to make certain that the cables are connected correctly.</p>	<p>When connecting POINT to ISOBUS the power port on the far left should be empty.</p> <p>The ISOBUS harness that provides power and connects POINT to the tractor must be plugged into the DT8 port on the far right of POINT.</p>  <p>Check the other end of the Scale-Tec ISO harness. The 9-pin port on the back of tractors is often dirty and the connector may not have a good retaining mechanism.</p>
<p>2. Make sure the POINT firmware is on an appropriate version. Newest is typically best but must be 1.8.15 or later for VT and 2.1.4 or later for PowerUp.</p>	<p></p>
<p>3. Make sure the correct settings are applied. This can be done using "Choose Mode" or by changing individual settings.</p>	<p>ISOBUS - ON: this mode enables the POINT to display on the VT and send basic weight information over ISO. This mode changes the CAN Mode parameter to ISOBUS.</p> <p>PowerUp: this mode enables all of the features in ISOBUS - ON in addition to allowing POINT to receive the PTO status messages from the tractor. This mode changes the CAN Mode parameter to ISOBUS and the ISOBUS Message Filter Bitmask parameter to PTO Filter Active.</p>
<p>4. Power cycle the tractor.</p>	<p>When the tractor key is turned off, the POINT and the tractor display should also shutdown.</p> <p>When the tractor is restarted, allow for the tractor display to fully restart. It can take several minutes after the tractor is running.</p> <p>Does the POINT show up on the VT after the tractor has been power cycled?          Yes - Step 5          No - Step 7</p>
<p>5. POINT appears on the VT. Is this customer utilizing PowerUP?</p>	<p>No - The system is working correctly</p> <p>Yes - Step 6</p>
<p>6. Turn on the PTO and watch the POINT indicator to see if it changes from GROSS to LOADING/UNLOADING.</p>	<p>If POINT reacts to the PTO being turned on and off, the system is working correctly.</p> <p>If POINT does not react to the PTO, the tractor is not sending the correct PTO status messages. This can be true for several reasons:</p> <ol style="list-style-type: none"> <li>The tractor software is out of date. This is common on 2008-2012 models. Have a dealer update the tractor.</li> <li>The tractor did not come from the factory with integrated ISOBUS. This is common on tractors made prior to 2010.</li> <li>The tractor did not come from the factory with an integrated PTO. High horsepower tracked equipment marketed for tillage are often sold without a PTO or the PTO may be a dealer add-on.</li> <li>The tractor does not conform to ISOBUS messaging standards. CAT Challenger C,D, and E series tractors do not transmit PTO status.</li> </ol>

**POINT ISOBUS TROUBLESHOOTING**

<p>7. Test for CAN HI and CAN LO at the DT8 end of the ISO Harness</p>	
	<p>Place black probe on Pin 1 for ground</p>
	<p>Pin 4 is CAN LO and should show -2.5V</p>
	<p>Pin 5 is CAN HI and should show +2.5V</p>
<p>8. If any part of step 7 testing fails or if the problem is intermittent in nature, replace the Scale-Tec ISO Harness.</p>	
<p>9. If all tests in step 7 pass, perform a factory reset on the POINT, reapply the profile/cal number, and repeat steps 3-5.</p>	
<p><i>POINT ISOBUS Troubleshooting. Retrieved March 27, 2025 from <a href="https://support.scale-tec.com/portal/en/kb/articles/point-isobus-troubleshooting">https://support.scale-tec.com/portal/en/kb/articles/point-isobus-troubleshooting</a></i></p>	

## ENABLE ISOBUS PTO AND GPS DETECTION FOR USE WITH REAP

POINT now allows both the detection of PTO status and GPS coordinates over ISOBUS. If a StarFire receiver is connected, POINT will use its position data to add Lat./Lon. coordinates to each load ticket that is recorded. To enable these features, follow the steps below. The POINT must be connected to ISOBUS using a HarvestMate cable (7609060).

1. Update Firmware (must be 2.2.6 or newer)

### FIRMWARE UPDATE

1. Make sure the POINT app on your mobile device is updated to the most current version. Most users already have automatic updates enabled on their mobile devices. This is the easiest way to keep all of your mobile apps updated to their current versions. If you have automatic updates enabled on your mobile device, continue to step 2. If you do not have automatic updates enabled, or you do not know, please see this help article to ensure you have automatic updates enabled on your iOS app.
2. Turn on your POINT scale display.
3. Watch the video available online for visual instructions, or continue reading the step-by-step instructions.
4. Open the POINT app on your iPhone or iPad.
5. In the app, select your POINT device.
6. Tap the device name above the weight (ex: Device:POINT-1-XX:YY).
7. Select "Firmware" from the menu.
8. On the next screen, press "Update Firmware."
9. On the next screen, press "Start" - make sure you have a good internet connection.
10. During the process, your POINT device may power off and on several times. There is no need to turn it back on during the update process.
11. When the screen says "Firmware is up to date," you have completed the process. In the app, if you want to return to the scale screen, press the arrow in the upper left corner of the screen.

2. Choose Mode and select "PowerUp"

### FIRMWARE UPDATE

POINT has several modes that it can operate in.

1. To select a different mode, touch the "Choose Mode" button at the bottom of the live scale screen.
2. Once the Modes screen opens, select which mode you would like to use.
3. POINT will return to the Live Scale screen once the mode has been changed successfully.

3. Power-cycle the tractor. Turning the key off should power off both the tractor and the scale. When the tractor is restarted, the scale should connect to the ISOBUS and the features should be active.

*POINT ISOBUS Troubleshooting. Retrieved March 27, 2025 from <https://support.scale-tec.com/portal/en/kb/articles/enable-isobus-pto-and-gps-detection-for-use-with-reap>*

**DATA DOWNLOADER TROUBLESHOOTING**

<b>PROBLEM</b>	<b>POSSIBLE CAUSE</b>	<b>SOLUTION</b>
Warning no device match was found.	Poor connection to cable.	Check for proper connection to cable.
	Poor connection of cable to serial port of computer.	Check for proper connection of cable to serial port of computer.
	Not connected to correct serial port.	Check port setting in the DTU program to be sure DDL is on the correct serial port.
	Faulty DDL.	Try another DDL.
	Other software installed that uses same serial port.	If any other installed software that requires a serial port is trying to run and there is only one serial port, the second software will not be able to run. If the DTU software had been loaded first and then the (eg. Palm Pilot) software, the Palm software could have a problem. This is a hardware allocation problem. For sites that need to run both, a second serial port must be added or you have to turn off all other software packages that may be using the 1 serial port.
No such file or directory.	File was not saved.	Resave file.
	File saved as incorrect format.	Save file as a text file (.txt).
	Data was not saved in a valid Windows file folder and/or directory.	Resave file in valid Windows file folder and/or directory.
Data will not transfer to PC.	Poor connection to cable.	Check for proper connection to cable.
	Poor connection of cable to serial port of computer.	Check for proper connection of cable to serial port of computer.
	Not connected to correct serial port.	Check port setting in the DTU program to be sure DDL is on the correct serial port.
Some information is not listed.	64K capacity of the DDL is filled.	Check capacity.
	Information may of been overwritten.	Resave file.
Dialog box and program locks up (not responding).	Computer error.	CRTL-ALT-DEL and end task, then restart computer.

### TRACK SYSTEM TROUBLESHOOTING

PROBLEM	POSSIBLE CAUSE	SOLUTION
Uneven tread wear	High amount of roading	Swap tracks side to side
Splits/opening on the side or top of tread	High amount of roading or overheat of tread	Swap tracks side to side. Replace tracks if necessary.
Chunking on guide lug sides	Track not aligned properly	Align track
	Side slope operation	Contact dealer
Breakaway of track guide lugs	Debris/material ingestion into track system	Contact dealer
Correct tensioning not possible	Verify position of track detensioning bolt at rear idler assembly.	Bolt fully retracted with no preload on spring applied
High temperature of idler or roller axle hub.	Bearing failure	Replace damaged bearing.
	Lack of lubricant	Check oil level in reservoir.
Mud/dirt buildup on idlers/midrollers	Operation in muddy, wet or sticky soil types	Clean mud/dirt regularly to prevent track damage.

**This page intentionally blank.**

Proper lubrication of all moving parts will help ensure efficient operation of your Kinze Grain Cart and prolong the life of friction producing parts.

## WHEEL BEARINGS

Wheel bearings should be checked and lubricated annually.

Raise wheel off the ground and support with axle. Remove the dust cap. Check for endplay in bearings by moving tire in and out. Rotate tire to check for roughness in bearings. If bearings sound rough, the hub should be removed and bearings inspected and replaced if necessary. Refer to [“Wheel Bearing Replacement” on page 3-45](#).

If bearing replacement is not necessary, while wheel is raised and dust cap removed, pump grease into hub until grease comes out through bearing rollers. Replace dust cap.



**20 Bolt Hub Shown**

## GEARBOX OIL LEVEL

Gearbox Oil Capacity . . . . . 1 $\frac{3}{4}$  Gallons . . . SAE 90 weight oil.

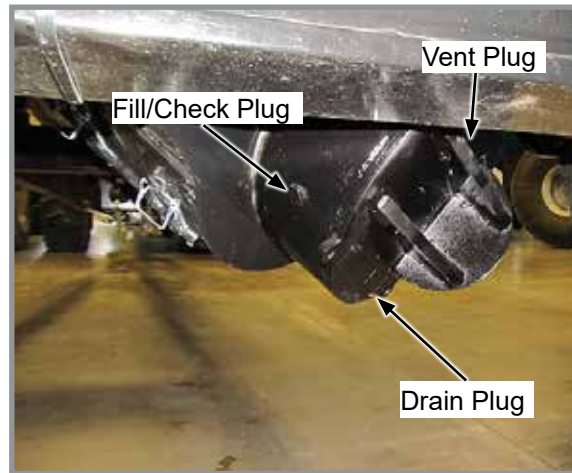

Remove plug from fill/check plug hole on the gearbox. Oil level should be even with fill/check plug hole. Inspect oil at end of each annual season of use for moisture and contaminants, if found, change oil before storage. A drain plug is located on the bottom of the gearbox.

## PTO SHAFT COUPLING

Clean and grease PTO shaft coupling each time PTO is installed.

Apply a coating of high-speed industrial coupling grease, such as Chevron® Coupling Grease meeting AGMA CG-1 and CG-2 Standards to extend life of shaft splines.

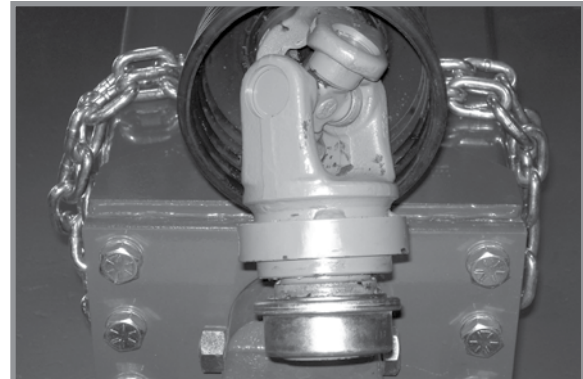

### GREASE FITTINGS

Those parts equipped with grease fittings should be lubricated at the frequency indicated with an SAE multipurpose grease. Be sure to clean the fitting thoroughly before using grease gun. The frequency of lubrication recommended on the following pages is based on normal operating conditions. Severe or unusual conditions may require more frequent attention.

<b>NOTICE</b>	<b>Extreme operating conditions such as dirt, temperature or speed may require more frequent lubrication.</b>
---------------	---

**NOTE: Disconnect PTO from tractor. Retract PTO assembly and rotate shield to expose grease fitting on PTO slide.**

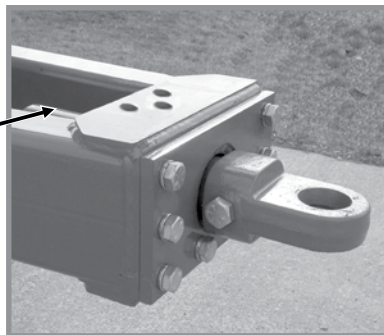

Swivel Hitch (Qty. 1)  
2022 - 2023 Production



Swivel Hitch (Qty. 1)  
2024 Production and On

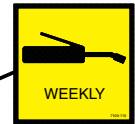

20 Bolt Hub Wheel Bearings  
(Qty. 1 Per Wheel Hub)

**NOTE: Loosen dust cap prior to pumping grease. Tighten after greasing.**

LUBRICATION POINTS

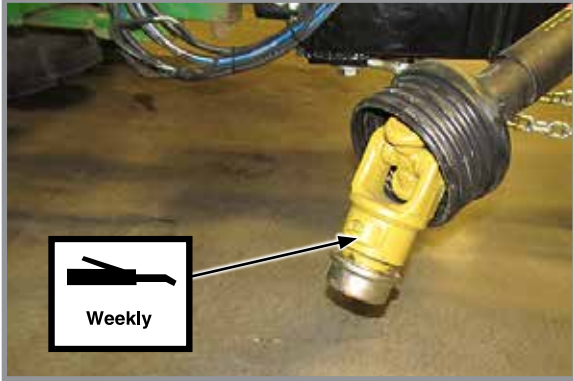

Overrunning Clutch - 1 fitting

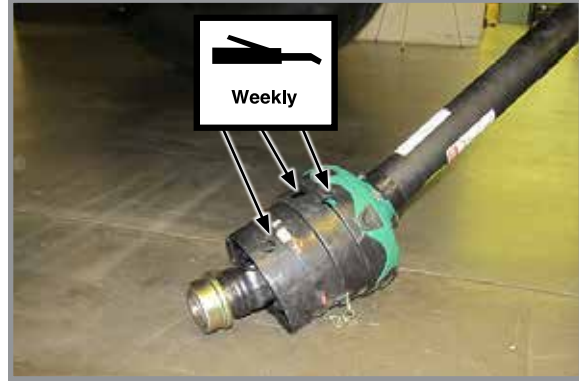

Continuous Velocity (CV) Joint - 3 fittings



Intermediate Drive Line, Rear - 1 fitting



Intermediate Drive Line, Center - 1 fitting



Intermediate Drive Line, Front - 1 fitting

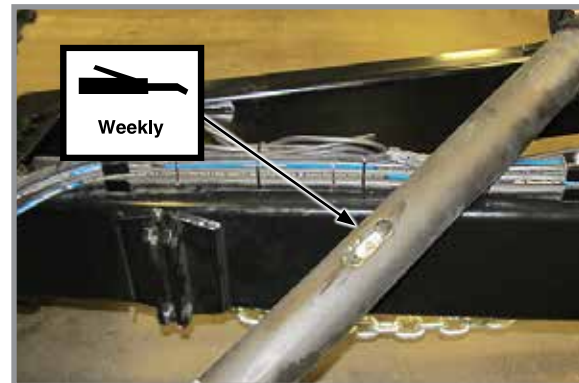

PTO Shaft - 1 fitting



Vertical Auger Center Bearing - 1 fitting

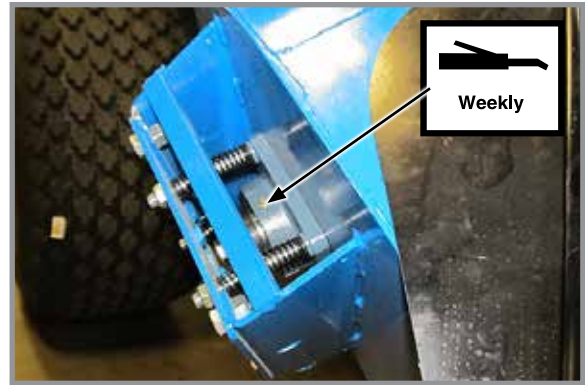

Vertical Auger Upper Bearing - 1 fitting

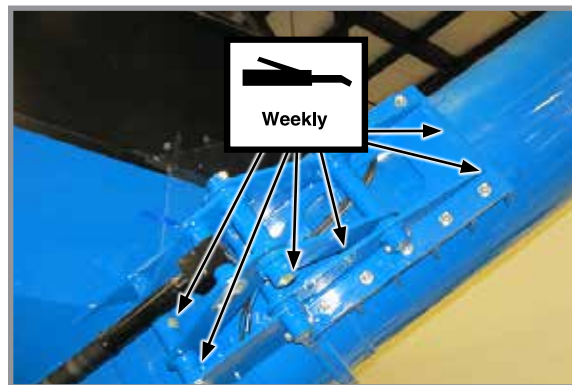

Fold Linkage and Hinge - 6 fittings

**TRACK SYSTEM MAINTENANCE - CAMSO**

**Every 50 Hours or Weekly**

GREASE UNDERCARRIAGE AND TRACK SYSTEM PIVOT POINTS

Visually check oil in mid rollers through clear covers.

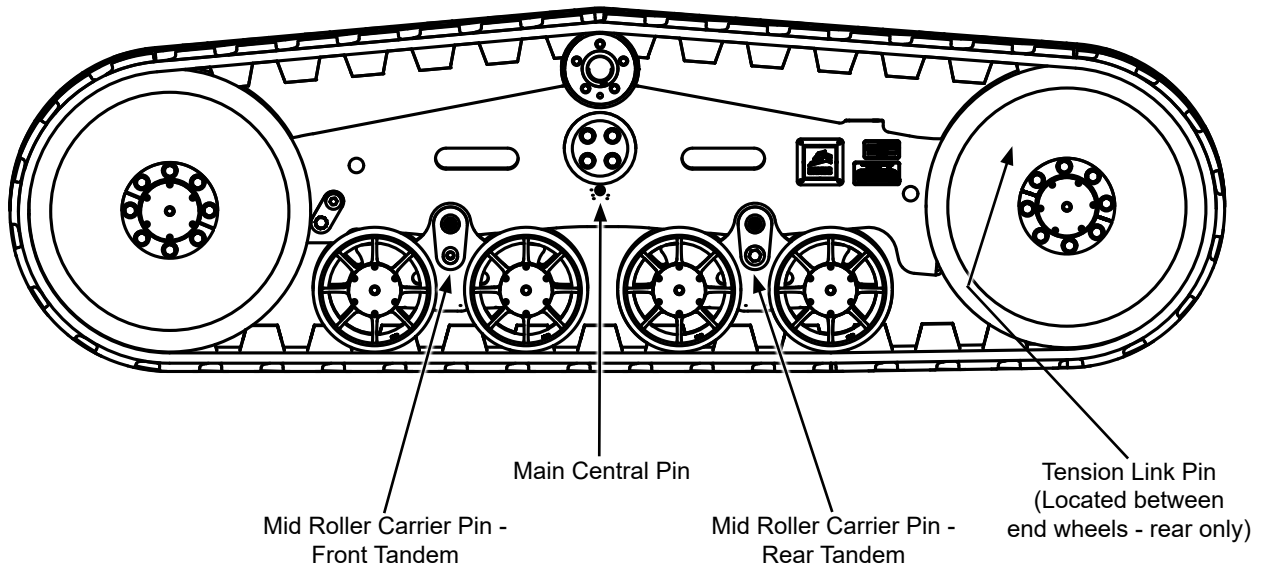

**Every 100 Hours or Monthly**

CHECK TRACK TENSION

System is self-tensioned via spring. Visually check track tension.

CHECK WHEEL BOLT TORQUE

**NOTE:** Always torque after wheel removal regardless of hours.



Wheel Bolt Torque Chart		
Size	Torque (N-m)	Torque (ft-lb)
M20	620 +/- 124	457 +/- 91

**Every 500 Hours or Yearly**

REPACK CARRIER ROLLER WHEEL BEARINGS

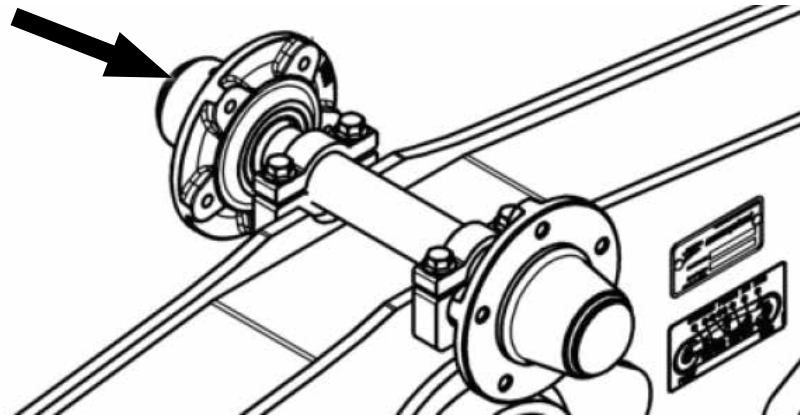

Bearing Lock Nut Torque Chart		
Size	Torque (N-m)	Torque (ft-lb)
N-06	10 +/- 2	7.4 +/- 1.5

**NOTE:** Torque lock nut while rotating or oscillating hub. If any lock nut slot and lock washer tang are aligned, bend the aligned tang into the slot to lock in place. If no slot or tang aligns, tighten the locknut until the most nearly aligned slot and tang line up. Bend the aligned tang into the slot to lock in place.

**Every 2000 Hours or Every 5 Years**

DRAIN AND REPLACE IDLER AND MIDROLLER RESERVOIRS

Use 10W30 Universal Transmission/Hydraulic Oil

	Torque		Oil Qty.	
	N-m	in-lb	ML	OZ
Mid Roller Clear Cover	4.5 ± 1	40 ± 9	290 ± 15	9.8 ± 0.5
Mid Roller Plastic Fill Plug	3 ± 1	27 ± 9		
Idler Metal Cover	15 ± 3	132 ± 27	500 ± 25	17 ± 1
Idler Metal Fill Plug	34 ± 7	300 ± 62		



**TRACK SYSTEM MAINTENANCE - TDS****Every 50 Hours or Weekly****GREASE UNDERCARRIAGE AND TRACK SYSTEM PIVOT POINTS**

Visually check oil in mid rollers through clear covers.

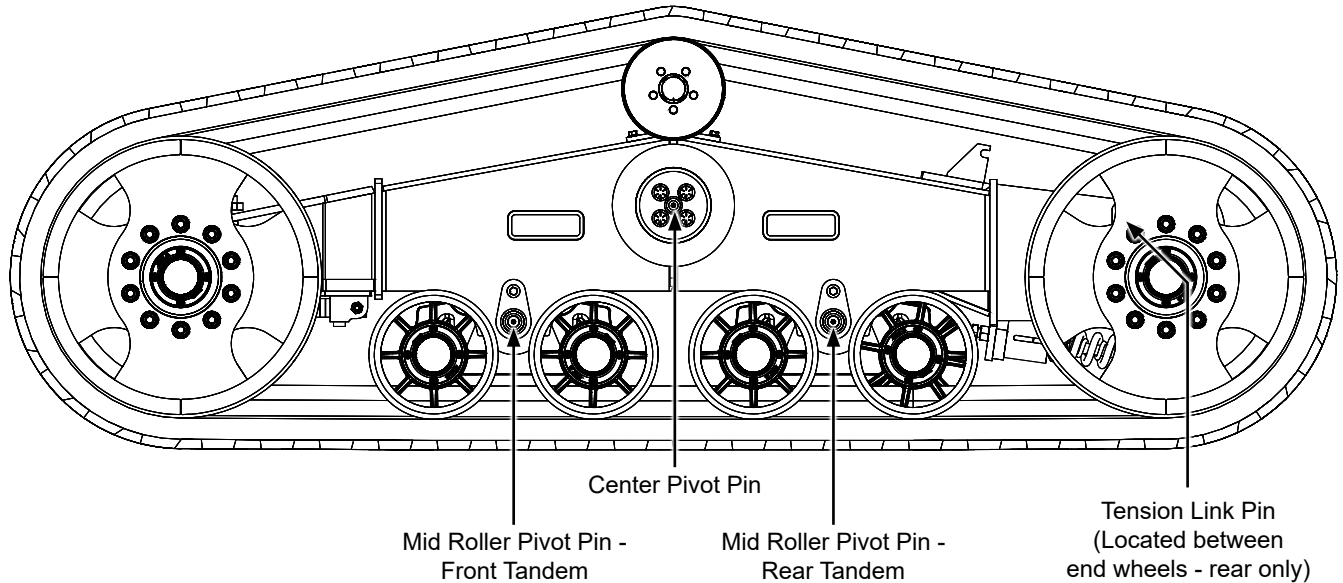
**Every 100 Hours or Monthly****CHECK WHEEL BOLT TORQUE**

Torque to 420-500 ft-lbs (*Tighten in Star Pattern*) **NOTE: Always torque after wheel removal regardless of hours.**

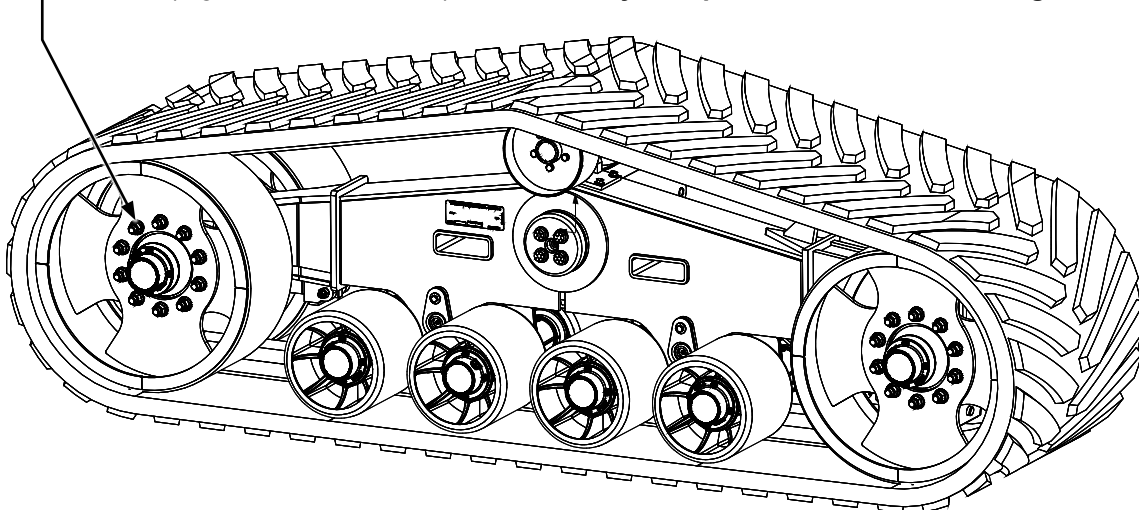

**Every 500 Hours or Yearly**

REPACK TOP ROLLER WHEEL BEARINGS

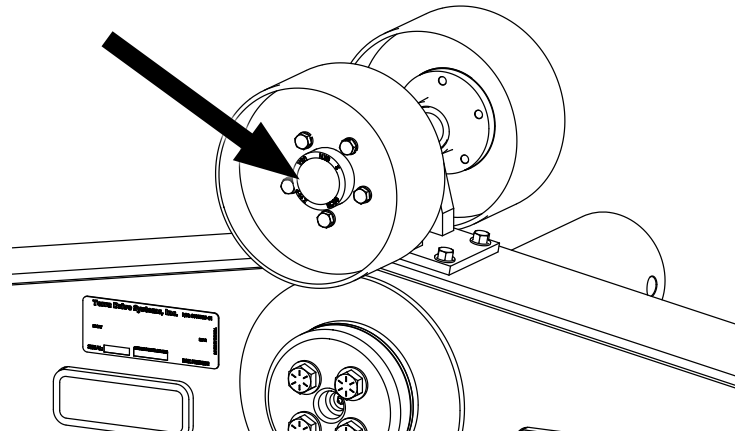

**Every 2000 Hours or Every 5 Years**

DRAIN AND REPLACE IDLER AND MIDROLLER RESERVOIRS

Use 80W90 Universal Transmission/Hydraulic Oil

	Measurements From Top of Sight Glass		Oil Qty.
	Min	Max	OZ
Idler	2"	.0625"	28 ± 0.5
Mid Roller	2"	.0625"	40 ± 1

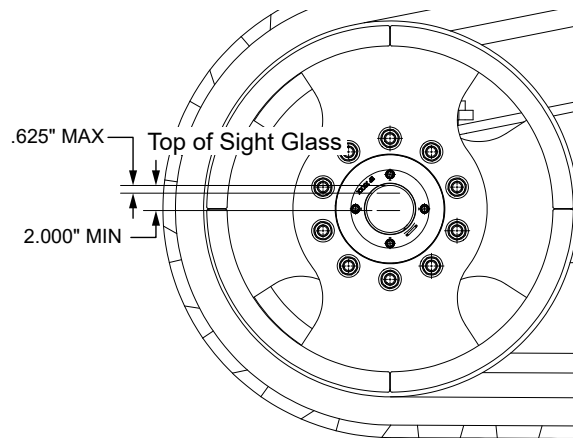

**This page intentionally blank.**

## CHECK TRACK ALIGNMENT

1. Prior to checking track alignment the implement should be empty.

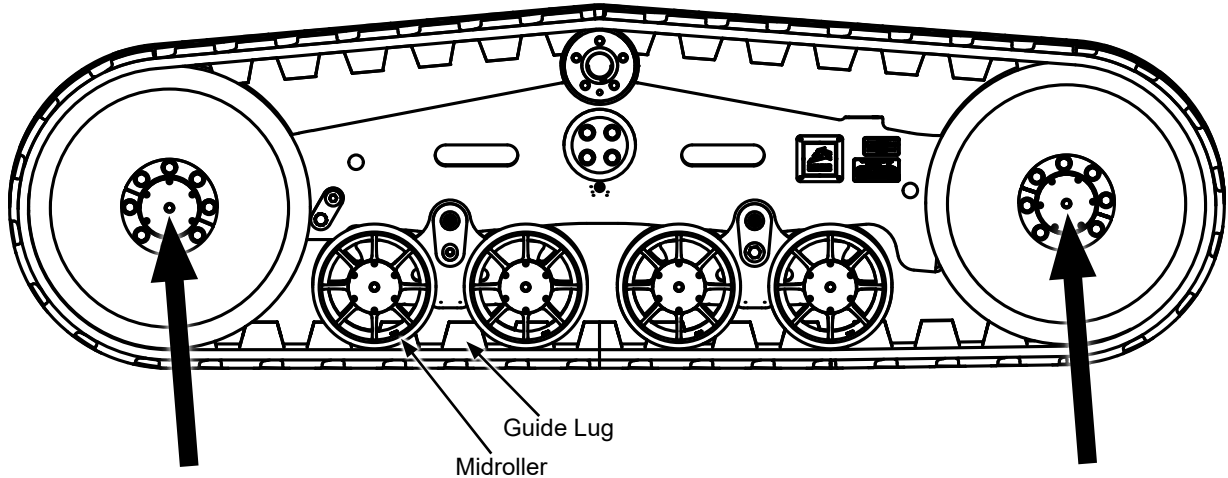

2. Measure the inside distance left to right. Undercarriage toe must be parallel to within  $\frac{1}{4}$ " (6mm). A suitable location for measurement is noted by arrows, shown on the diagram above, between the idler hub covers.
3. Pull the implement on a flat surface for a suitable time frame, allowing the belts to relax and move freely on the undercarriage rollers.
4. Drive in a straight line for roughly 200 feet and coast the tractor to a stop. Place the tractor in PARK and apply the emergency brake. Do not apply braking action during this process as sudden stops can affect track position during the alignment process.
5. Using a  $\frac{1}{4}$ " x 4" x 8" shim slide between the front midroller and guide lugs. Bridge guide lugs with the shim maintaining pressure on 2 lugs minimum.
6. If the shim fits freely between the lugs and midroller on both sides of the undercarriage the alignment is correct. If the shim binds and does not fit between the midrollers/guide lugs track adjustment is necessary.

**TRACK SYSTEM TORQUE VALUES - TDS**

**UNDERCARRIAGE AND TRACK SYSTEM PIVOT POINTS**

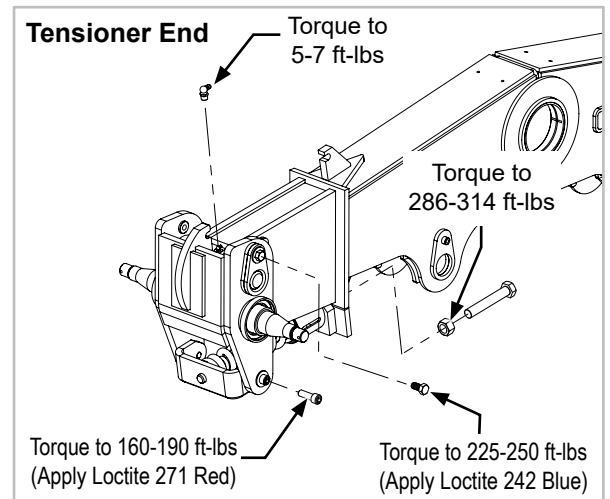
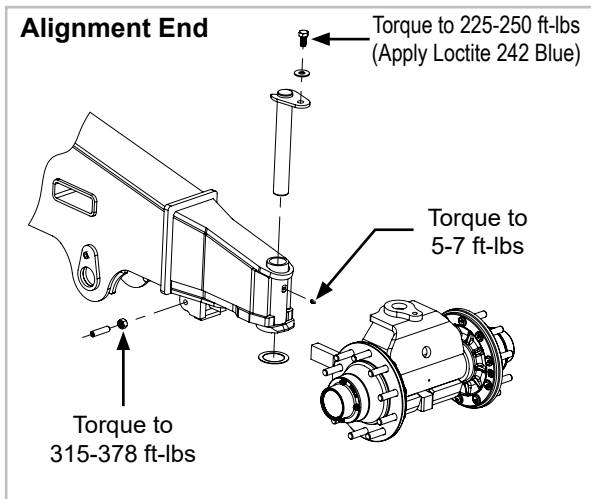
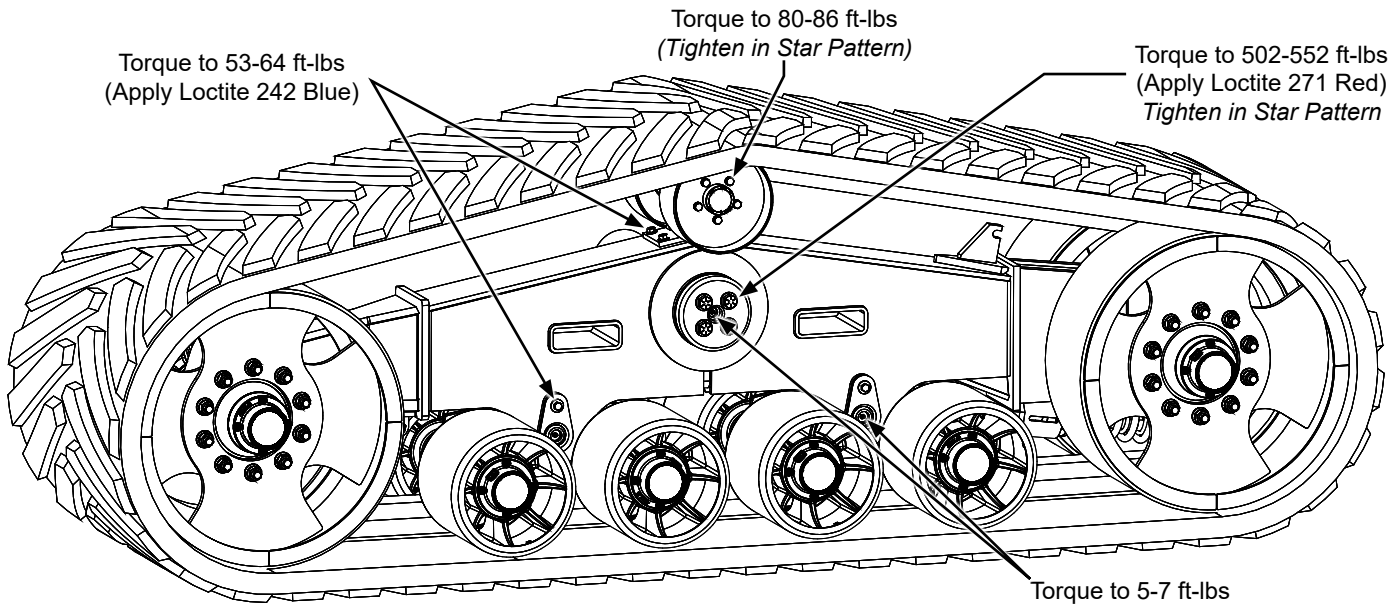

**CHECK TRACK TENSION**

System is self-tensioned via spring. Visually check track tension.

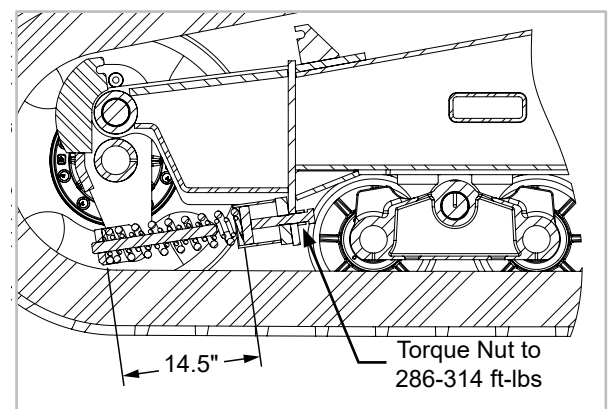

Torque to 420-500 ft-lbs (*Tighten in Star Pattern*) **NOTE: Always torque after wheel removal regardless of hours.**

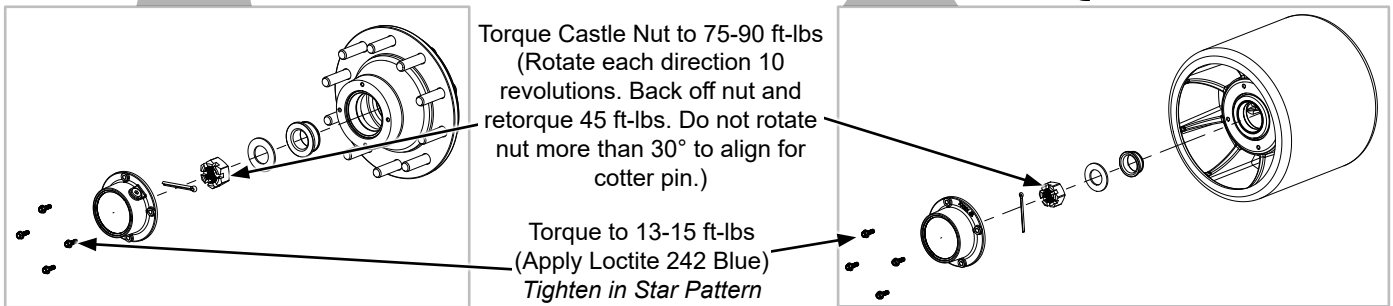
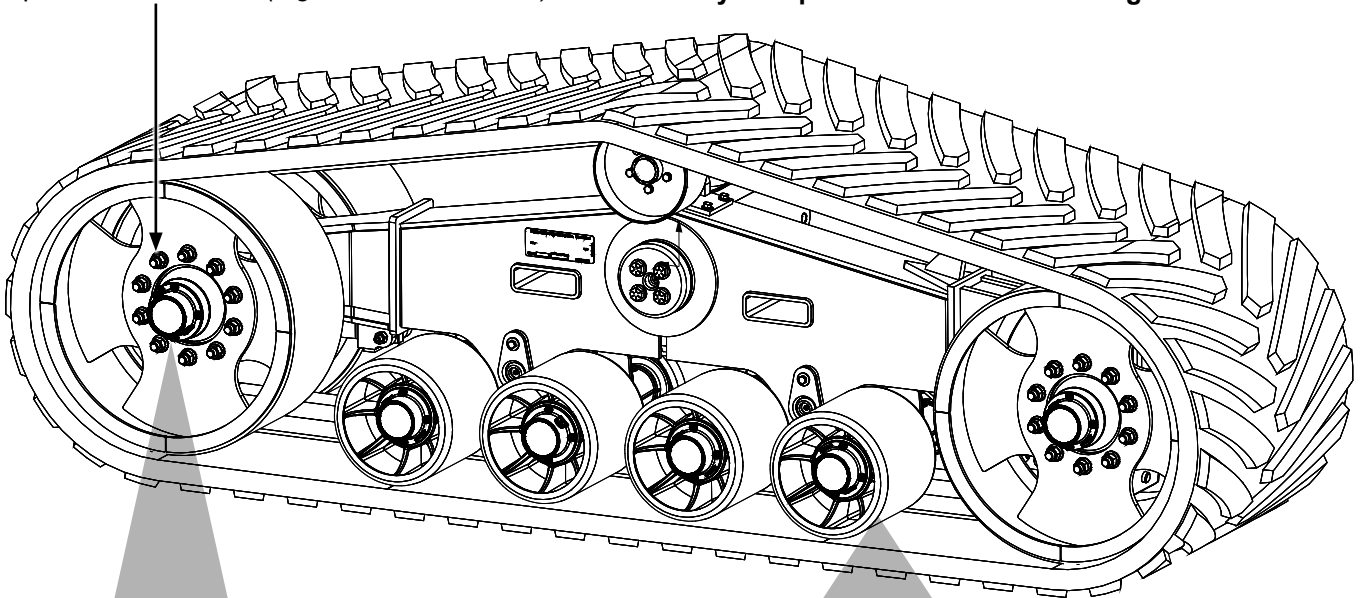

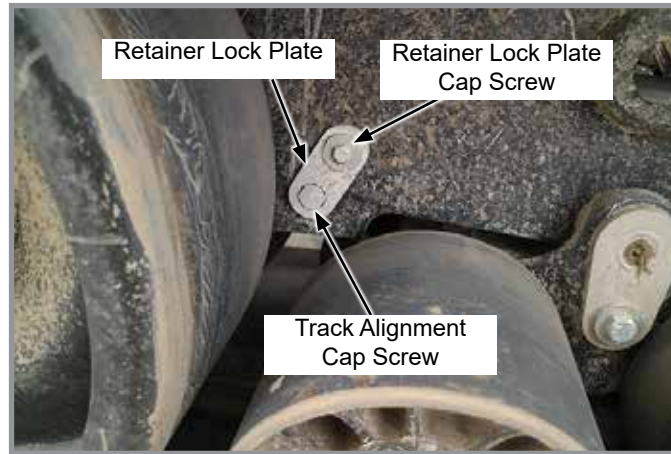
**TRACK ALIGNMENT PROCEDURE - CAMSO****Camso**

1. Remove the retainer lock plate cap screw and lock plate from the inboard and outboard sides of the track needing adjustment.
2. Loosen track alignment cap screw counterclockwise 1 - 1½ turns on the side of the undercarriage you want the track to move towards.
3. Tighten the track alignment cap screw on the opposite side to specification. (Cap screw torque is (221 ft-lb) 300 N-m. Tighten cap screw loosened in step 2 to the same specification.

**NOTE: A single full turn is the standard increment during adjustment. Lessen this amount as final adjustment is approached.**

4. Recheck track alignment and adjust until suitable clearance is obtained on both sides of the guide lugs.

**NOTE: Lock plates are reversible for double the index increments. If needed, increase torque on the special cap screw slightly allowing advancement to a suitable lock plate position.**

5. When alignment is complete, reinstall the lock plates and tighten cap screws to their required torque specification of (95 ft-lb) 130 N-m).

## TRACK ALIGNMENT PROCEDURE - **TDS**

To properly align the track system, perform the procedure on a smooth, flat, and level surface with sufficient straight travel distance. First, pull the track system in a straight line for approximately 500' to determine if alignment is needed. Check between both sets of large idler wheels at each end of the track system. There should be  $\frac{1}{4}$ " gap between the guide lugs and each idler wheel edge. If the gap is present on both sides of the guide lugs, no adjustment is required. If the guide lugs are tight to one of the idler wheel sides, the belt alignment should be adjusted to move the guide lugs away from the wheel.

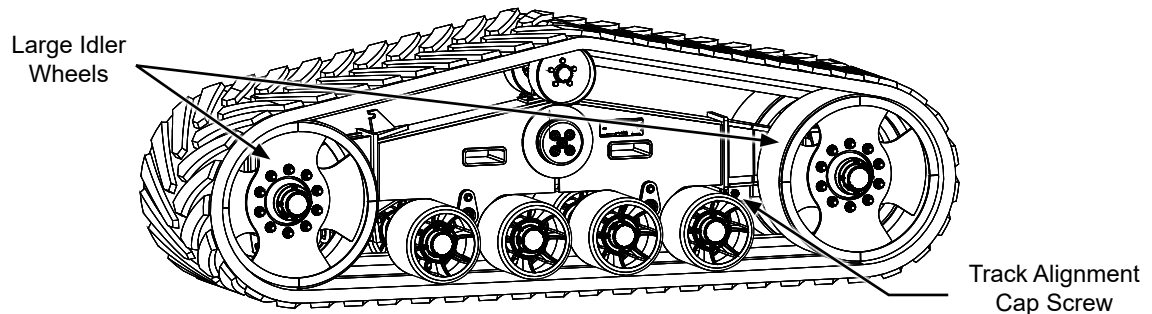

1. To adjust alignment, loosen the jam nut using a  $1\frac{1}{8}$ " socket on the side of track that guide lugs are rubbing.
2. Using a  $\frac{3}{8}$ " hex bit, turn adjustment screw counterclockwise  $1\frac{1}{2}$  - 2 turns on the side that is rubbing.
3. Loosen jam nut on opposite side of the track and tighten adjustment screw.
4. Torque both jam nuts to 315 ft-lb.
5. Drive in a straight line for 500' and then recheck clearance. Repeat this process until track belt is in proper alignment. For fine adjustment lessen the adjustment screw rotation.

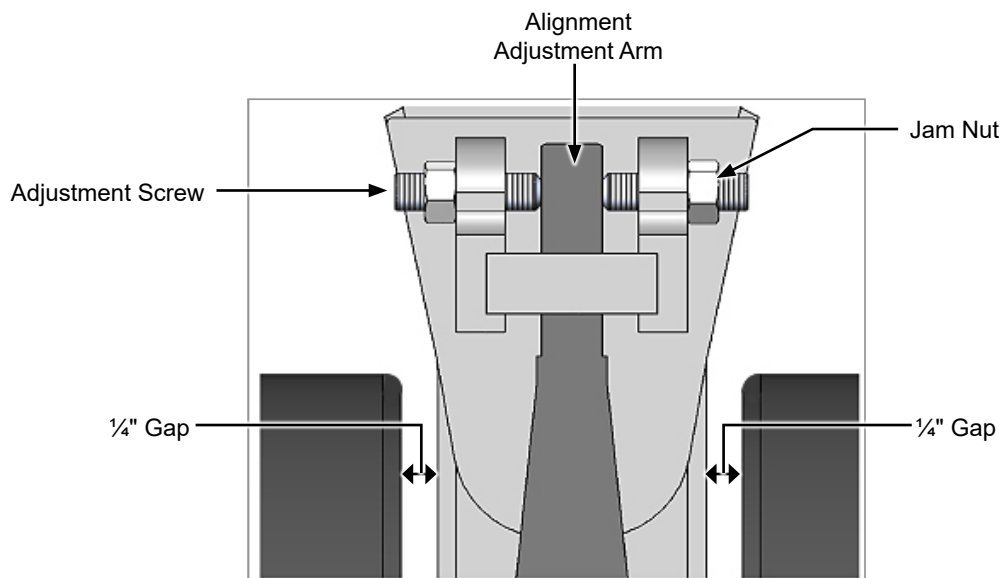

## TRACK SYSTEM INSPECTION

### Track System

Inspect track system for material build-up on frames and wheels. Clean material from undercarriage.

### Idlers and Midrollers

Check the general condition of the idlers and midrollers, making sure material buildup is not occurring. If any material buildup is found, it must be removed or track damage may result.

### Rubber Track Guide Lugs

Guide lugs keep the track on the track system. Proper alignment of the track is essential to improving overall life and decreasing operating costs. If track is misaligned or operating on side slope, guide lug wear or damage may occur. Also guide lug damage may occur if proper break-in procedures are not followed or system is operated outside the maximum speed recommendations listed in this manual. Monitoring guide lugs condition will alert the operator to an issue and generally if corrected early prior to loss of performance or durability.

### Track Carcass

Inspect track surface to remove imbedded stones or debris. This contamination can work its way into the track and damage the steel cable.

Steel wire may come out from the track carcass without affecting the performance of the track. Remove loose wires by cutting them at the rubber surface.

### Track Tread

Muddy soils usually cause limited wear, while roading long distances can bring about accelerated tread wear. Due to the crown of the road, and deflection in the system, the tread closest to the machine will tend to wear faster than the tread on the outer portion of the track. Adhere to speed and weight limitations. Refer to [“Track Transport Speeds” on page 2-17](#)

### Adjusting Track Tension

Tension is pre-set at the factory and requires no adjustment during operation. Provision is made to detension the track system allowing for removal of the rubber track.

**OFF SEASON STORAGE FOR TRACKS**

For optimum life, tracks should be stored indoors, in dry environment with a temperature between 40° - 77° (5° - 25° C). The tracks should not be exposed to direct sunlight or heat. No petrochemicals and related vapors, no electrical devices producing ozone should be placed in the same area.

Should it be necessary to disassemble the tracks from the undercarriage, lay them on the ground on one edge avoiding bending radius less than 30" (750 mm). Do not lay the rubber components on dirty surfaces contaminated by oil, grease or other chemical products

Do not paint rubber components.

## TRACK REMOVAL

**WARNING**

Pinch point could result in serious injury. Install safety lock on cylinder before removing track.



**IMPORTANT:** A detensioning kit (PN A24944) is required for track removal and available from Kinze. Contact your Kinze dealer.

**NOTE:** A Porta Power is also required for track removal. Kinze recommends Blackhawk 10 Ton Porta Power Model B65115.



1. (Camso Only) Remove plugs on rear track frame.



2. Attach a cylinder end cap to each end of the Porta Power.

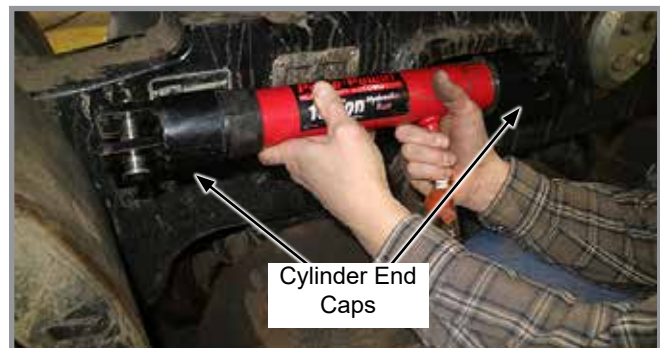

**TRACK REMOVAL (CONTINUED)**

3. Install one end of Porta Power on existing hook located between rear idlers.



4. (Camso Only) Place detensioning mount where plugs were removed in step 1. Install other end of Porta Power on mount and secure with two M16 bolts.



**NOTE: Ensure Porta Power hose is positioned as shown to avoid interference when removing idler wheel.**

5. Pump the Porta Power until the tensioning spring is fully compressed.



**TRACK REMOVAL (CONTINUED)**

6. Camso  
Remove the rear M20 idler wheel bolts and torque plate castings. Remove idler wheel.

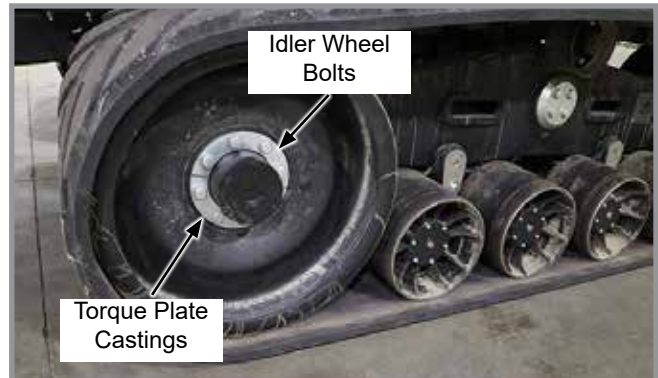

TDS  
Remove M22 nuts and then remove idler wheel.

7. Install cylinder lock plate on Porta Power cylinder. Install locking pin in cylinder lock plate.



 <b>WARNING</b>	<p>Idler wheels weigh 200 lbs (90 kg) and will roll easily on a firm surface. Place a block under removed wheels to prevent rolling and potential injury.</p>
--	---

8. Utilizing existing fork lift pockets or properly rated jack and safety stands, raise the undercarriage until there is sufficient clearance between the midwheels and track guide lugs.

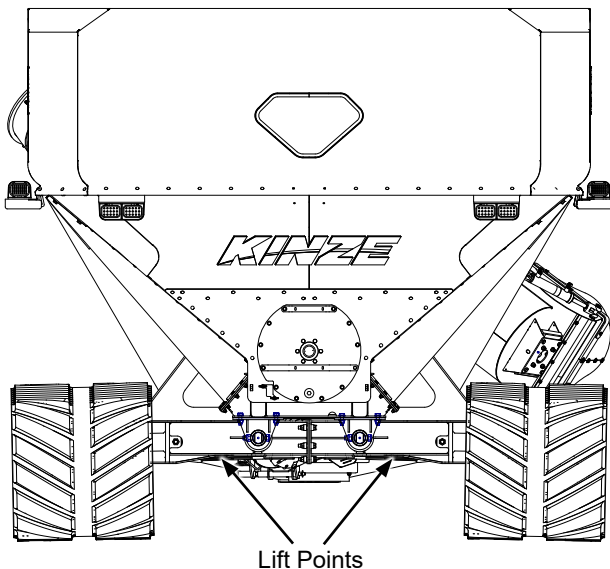

## TRACK REMOVAL (CONTINUED)

9. Using a suitable lifting device, lift the track belt slightly to provide clearance between the carrier and track guide lugs.

**NOTE: If using a forklift or other steel lifting device, ensure the tines or lifting surface does not have sharp edges or track damage may occur.**

10. Lift the track up and away from the undercarriage, placing in a suitable location. Place track on its side.

## TRACK INSTALLATION

1. Raise the undercarriage to allow for the lower surface of the belt to slide underneath.
2. Lift the track and install on the top carrier rollers. Push the bottom of the track under the midrollers aligning with the front and rear idlers.
3. Install the idler wheels removed previously, ensuring the guide lugs are positioned properly between the midrollers and idlers.

### Camso

Torque M20 bolts on idler wheels to 457 ft-lb (620 N-m).

### TDS

Torque M22 nuts on idler wheels to 420-500 ft-lb (569-678 N-m), tighten in a star pattern.

4. Lower the undercarriage assembly to the ground.
5. Remove lock from Porta Power cylinder.
6. Release pressure from Porta Power and remove.

**IDLER WHEEL SEAL AND BEARING REMOVAL AND INSTALLATION - CAMSO**

1. Remove locking washer and thrust washer.

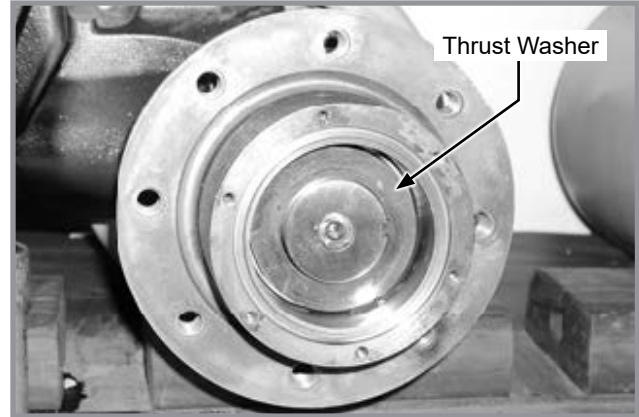
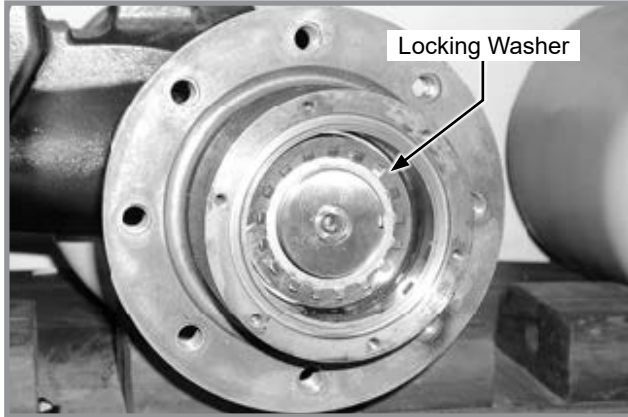

2. Remove hub to dislodge outer bearing cone and remove bearing from axle, then remove inner bearing cone.

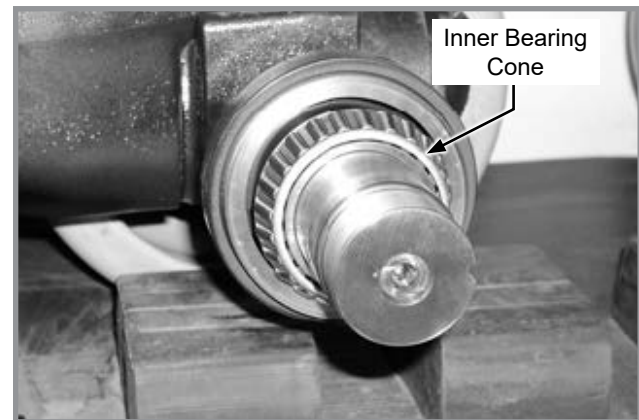
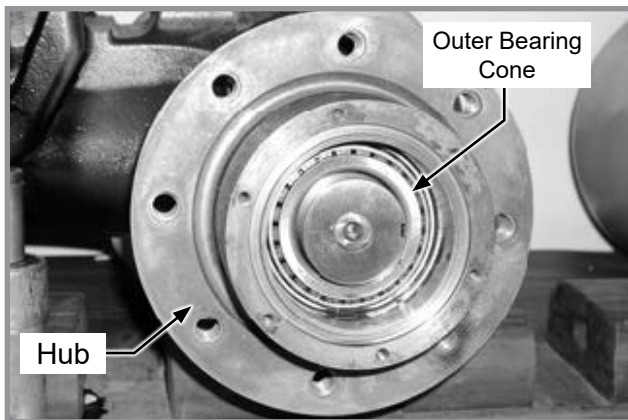

3. Remove inner half of mid-roller face seal and load ring from collar ring.

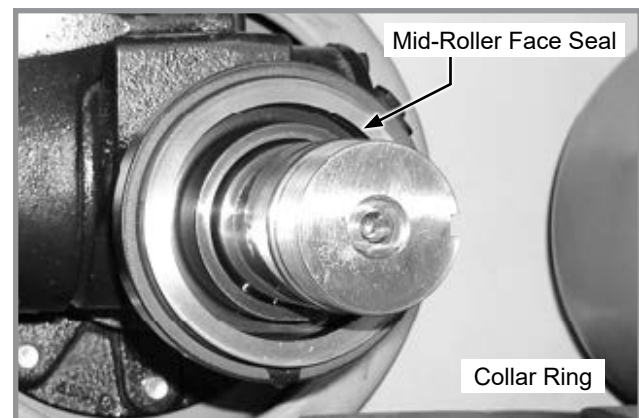

4. Remove outer face seal and load ring from hub.

**NOTE:** If replacing face seals only proceed to Step 2 in [“Mid-Roller Wheel Seal and Bearing Installation - Camso”](#) on page 3-24 Section. If there was a bearing failure proceed to next step.

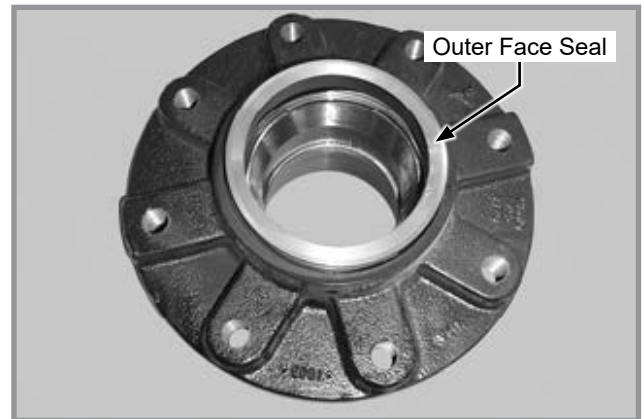

5. If replacing bearings use a bearing driver from the opposite side to remove inner and outer bearing cups. Clean and inspect all parts for wear or damage.
6. If collar ring is damaged or leaking go to the Roller Axle Removal and Installation section for collar ring removal.

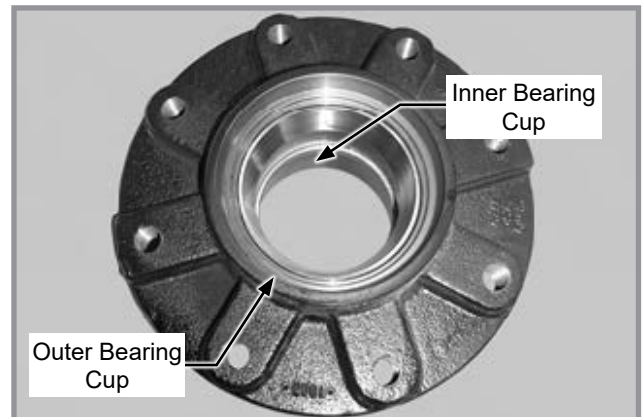

**MID-ROLLER WHEEL SEAL AND BEARING INSTALLATION - CAMSO**

1. Use a bearing driver to install both bearing cups in hub until they are seated firmly against inner shoulder of hub.

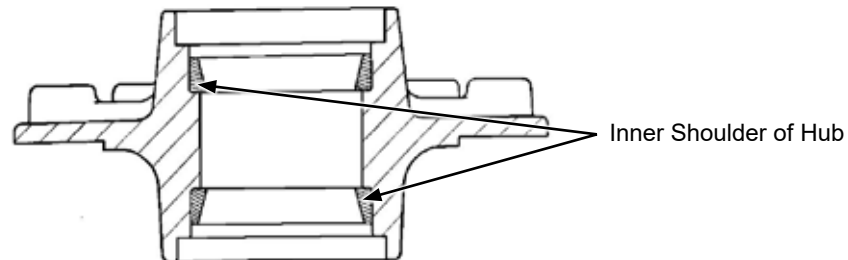

2. Use denatured alcohol to clean inner bearing cup and seal contact area. Wipe seal contact area with a clean lint free cloth.

**NOTE: Be sure no alcohol is puddled in seal contact area.**

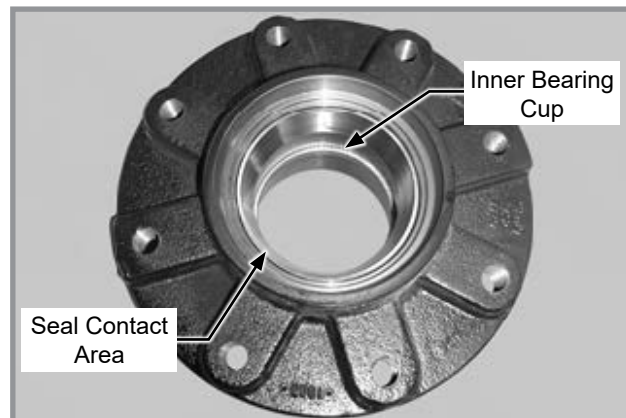

3. Install load rings on face seals.

**NOTE: Be sure load rings are correctly installed on face seals as shown below.**

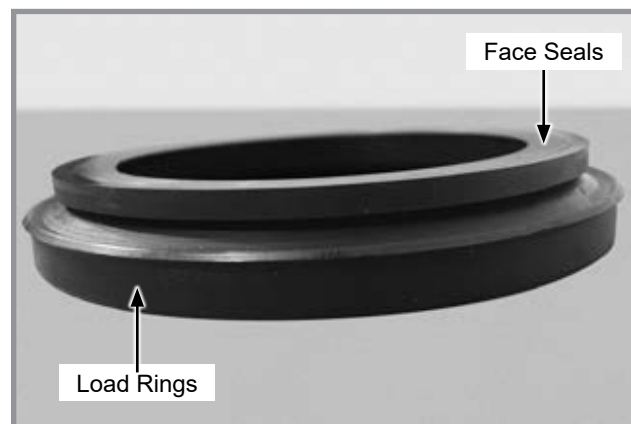



**METAL FACE SEAL PREPARATION AND INSTALLATION - CAMSO**

Metal face seals are made of a hard and brittle metal alloy with a highly polished contact surface. Never place seal rings face down on a hard or rough surface.

Before seal installation the undercarriage must be completely cleaned and dried. The hubs, bearings, and axles must be thoroughly cleaned and dried. Flood wash bearing cups and seal mounting areas with denatured alcohol or a fast evaporating electrical contact cleaner (use a pump type spray bottle to apply denatured alcohol). Wipe parts with a clean LINT FREE cloth. All parts **MUST** be free of dirt, debris, and grease. Replace any damaged parts.

**Metal Face Seal Installation**

Apply even pressure to outer edge of tool to install O-Ring and seal evenly in hub or axle.

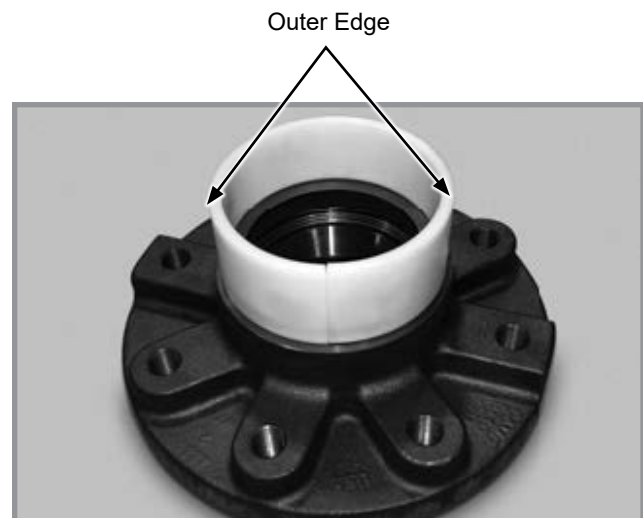
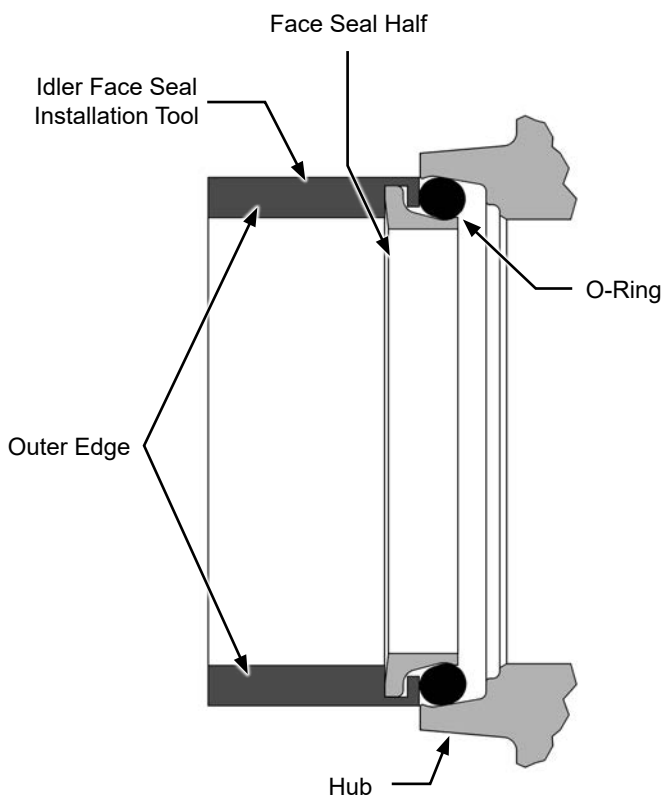

1. Lubricate seal load ring with denatured alcohol use the service installation tool to install seal and load ring in hub.

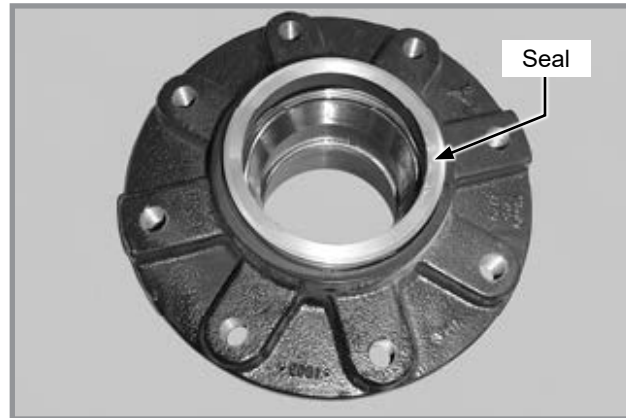

2. Flood collar ring with denatured alcohol to remove any dust or lint from seal cup. Use installation tool to install face seal assembly on collar ring. Install inner bearing cone on axle.

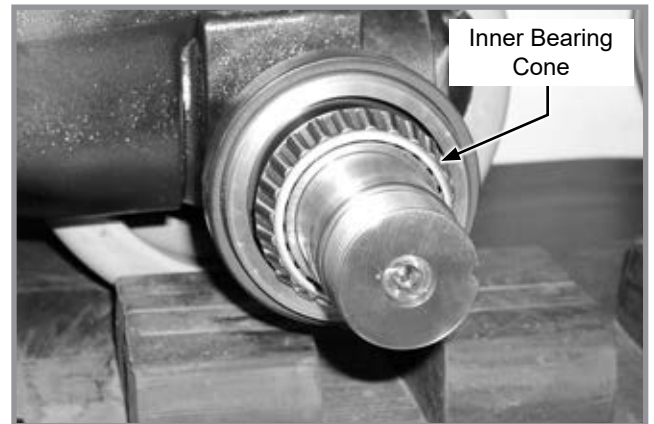
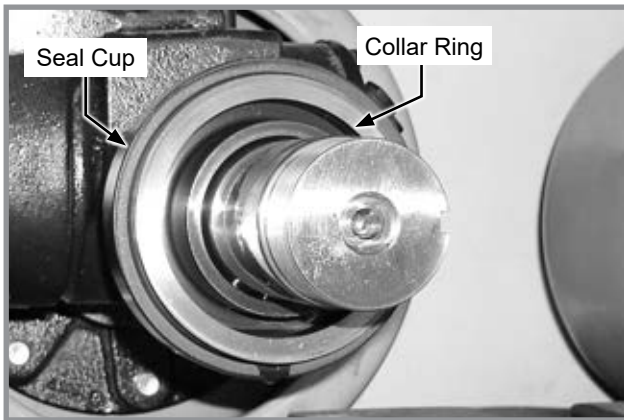

3. Carefully install hub assembly on axle without dislodging inner bearing and face seal until face seals make contact. Hold hub assembly in Steps 4 and 5.

Install outer bearing cone.

**NOTE: The hub MUST be held in place with slight pressure against face seals until lock nut is installed in Step 5.**

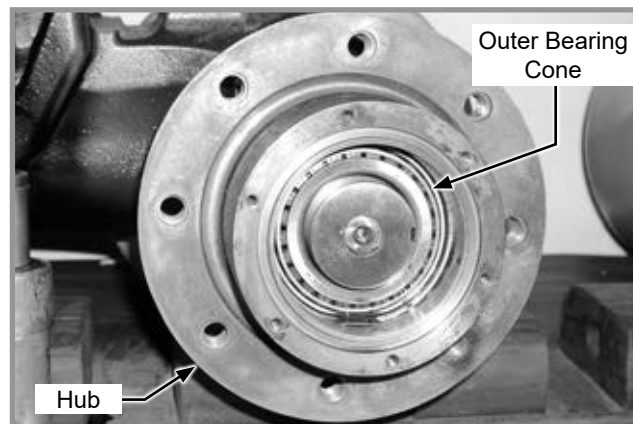

1. Install thrust washer on axle, then install locking washer.

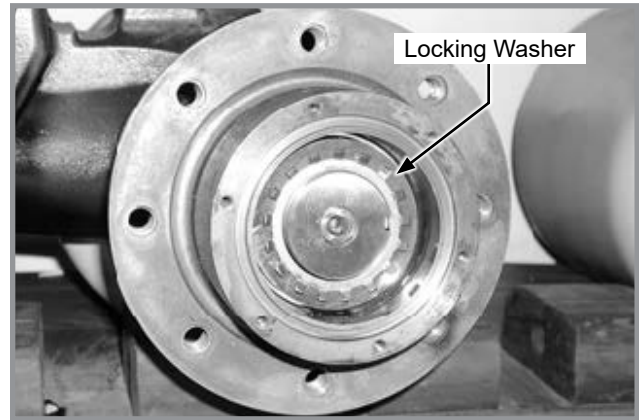
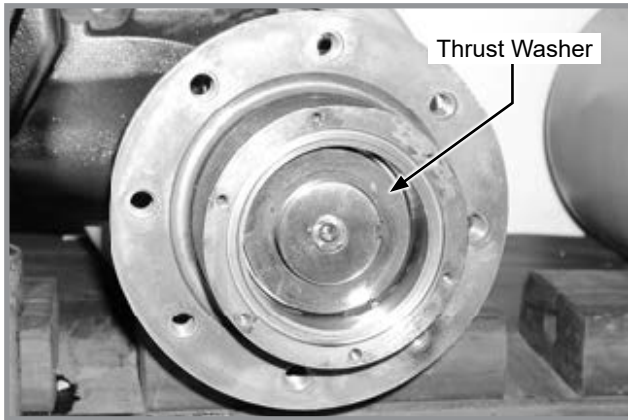

2. Install locknut and tighten to 32 ft-lb (43 N-m). Rotate hub five revolutions and check nut for correct torque.

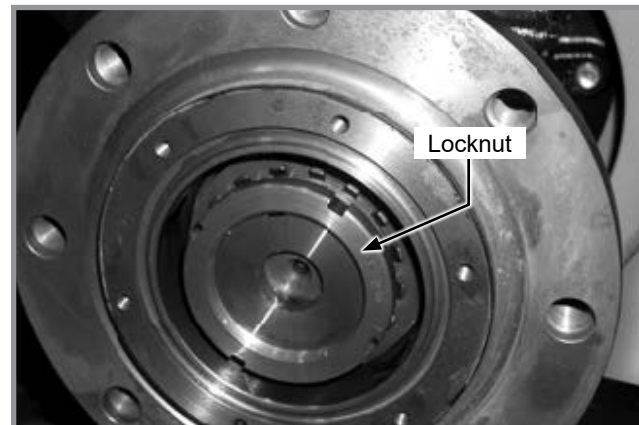

3. Align one of four lock nut slots in the lock nut with nearest tab on locking washer. Bend lock washer tab into slot.

**NOTE: If slot and tab does not align rotate locknut clockwise to align with nearest tab.**

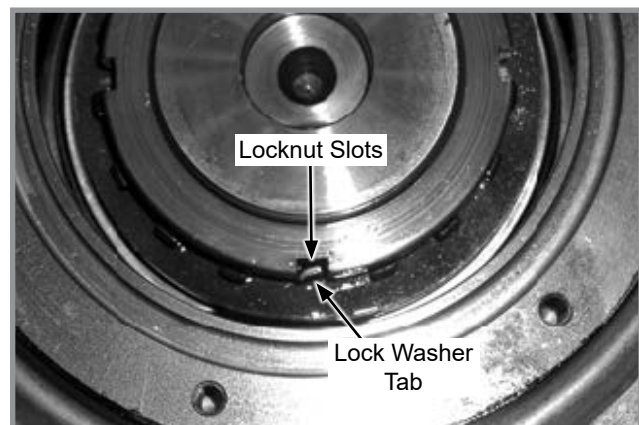

4. Install a new hub cover O-Ring.

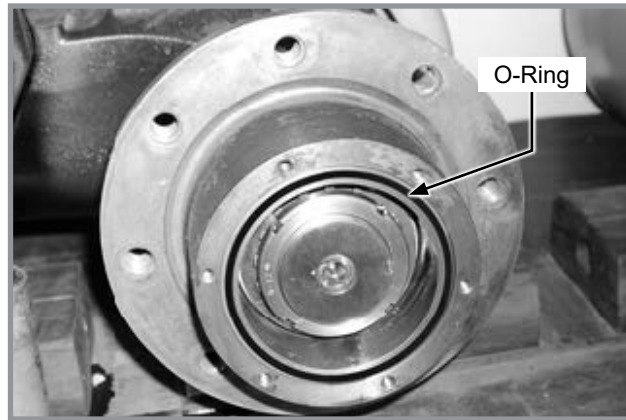

5. Install hub cover and six retaining bolts. Tighten bolts in a cross pattern evenly to 132 in-lb (11 ft-lb) (15 Nm).

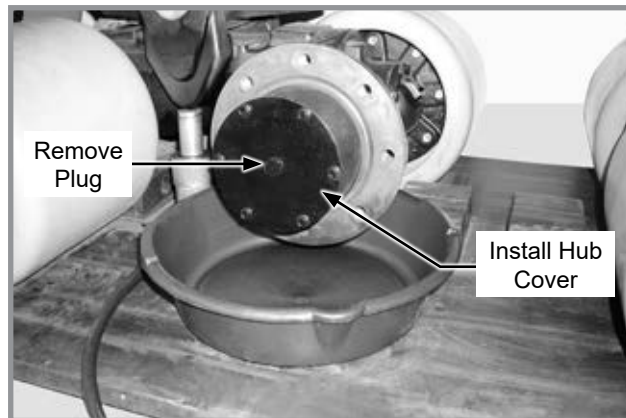

6. Remove plug.

#### Camso

Fill hub with 7.3 fl oz (215 ml) of Northland Transdraulic Fluid or equivalent. Oil level must be at bottom of fill plug hole. Tighten plug to 25 ft-lb (34 Nm).

#### TDS

Fill hub with oil refer to [“Drain and Replace Idler and Midroller Reservoirs” on page 3-9](#). Oil level must be at bottom of fill plug hole. Tighten plug to 25 ft-lb (34 Nm).

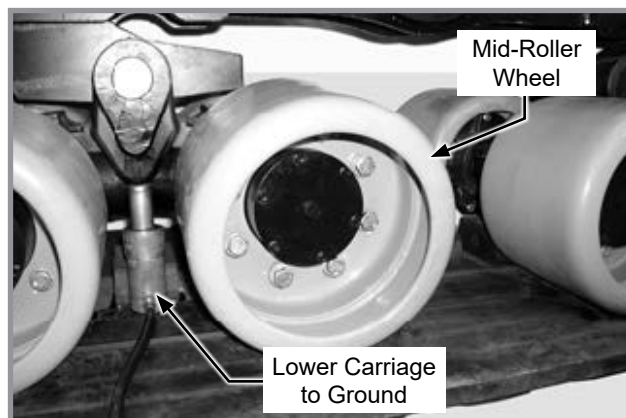

MID-ROLLER WHEEL SEAL AND BEARING REMOVAL AND INSTALLATION - **TDS**

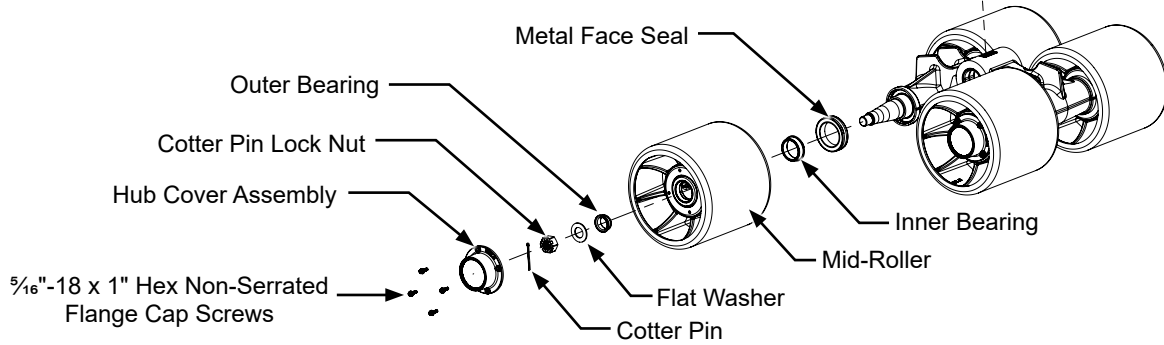

1. Remove hub cover assembly.
2. Remove cotter pin and hex nut to dislodge flat washer and outer bearing.
3. Remove mid-roller, inner bearing, and metal face seal. Discard metal face seal.
4. Remove the other metal face seal from mid-roller. Clean inner part of mid-roller wheel, using brake cleaner or equivalent. **NOTE: If inner part of roller is rough with rust, use fine sand paper or emery cloth to smooth out. Be careful not to sand down too much of the "lip" that holds seal in place.**

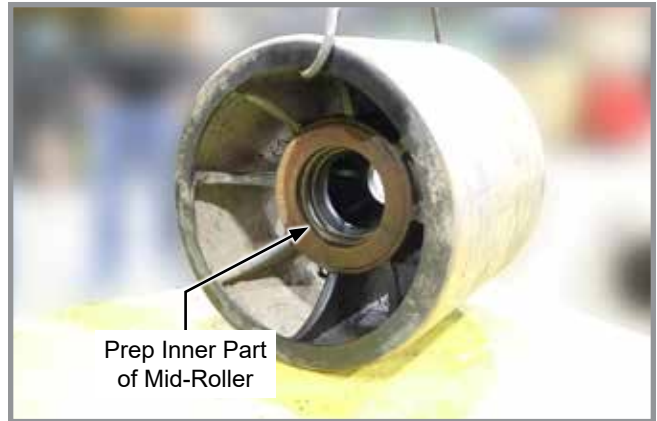

5. Refer to ["Hydraulic Hose Life" on page 3-48](#), then install inner bearing and seal into mid-roller.

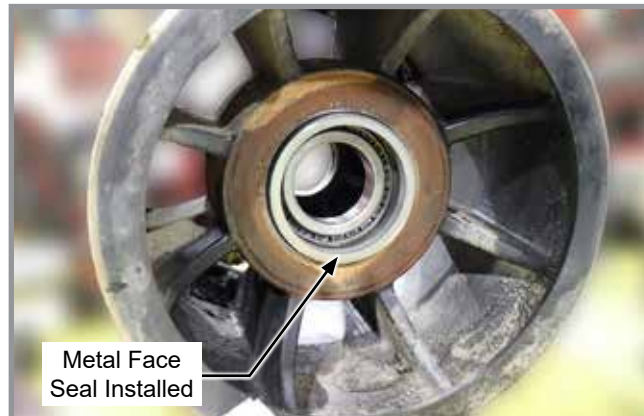

6. Clean spindle making sure there is not oil or debris in the area that the O-Ring seats.
7. Refer to [“Hydraulic Hose Life” on page 3-48](#) and then install seal onto spindle.



8. Reinstall mid-roller onto spindle. **NOTE: Be sure seals are correctly installed without dislodging inner/outer bearings and metal face seals until seals make contact.**
9. Install outer bearing and flat washer. Then install lock nut and torque to 75-90 ft-lbs. Rotate each direction 10 revolutions. Back off nut and retorque to 45 ft-lbs. Do not rotate nut more than 30° to align for cotter pin. **NOTE: The hub MUST be held in place with slight pressure against face seal until lock nut is installed.**
10. Install cotter pin through nut and bend around nut.
11. Reinstall hub cover. Apply loctite 242 (blue) to hardware, tighten in star pattern. Torque hardware to 13-15 ft-lbs.

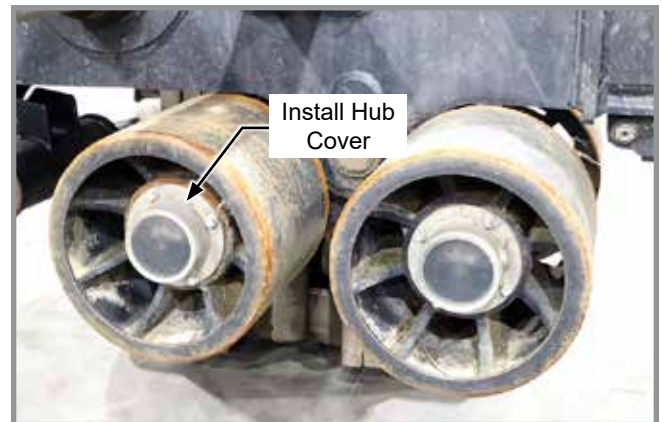

12. Refill oil. Refer to [“Drain and Replace Idler and Midroller Reservoirs” on page 3-9](#)

#### PREPARE METAL FACE SEALS FOR INSTALLATION

1. Place seal on service installation tool, making sure it is properly sleeved and seal is not twisted or skewed.
2. Lubricate seal with denatured alcohol.
3. Using the service installation tool install seal.
4. Use denatured alcohol and a lint free wipe to clean seal face. Ensuring seal face is thoroughly cleaned and no fine particles of dust are on seal.



**This page intentionally blank.**

## IDLER WHEEL SEAL AND BEARING REMOVAL AND INSTALLATION - TDS

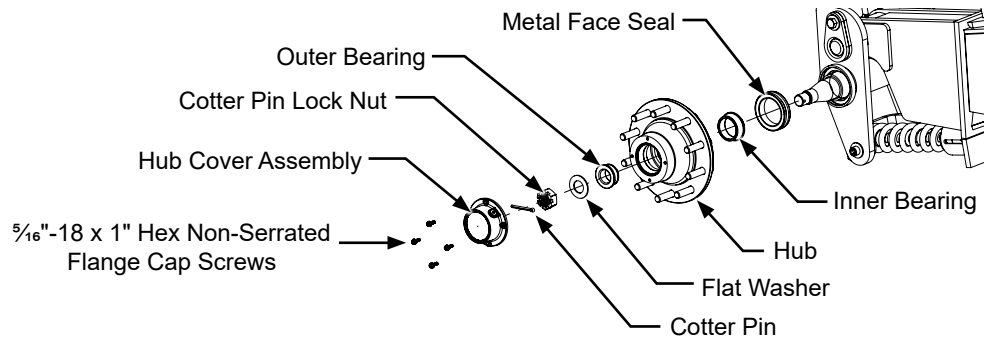

1. Remove hub cover assembly.
2. Remove cotter pin and hex nut to dislodge flat washer and outer bearing.
3. Remove hub, inner bearing, and metal face seal. Discard metal face seals.
4. Remove the other metal face seal from hub. Clean all housing components, using brake cleaner or equivalent. **NOTE: If inner part of hub is rough with rust, use fine sand paper or emery cloth to smooth out. Be careful not to sand down to much of the "lip" that holds seal in place.**
5. Clean spindle making sure there is not oil or debris in the area that the O-Ring seats.
6. Wipe down each seal with non-petroleum-based solvent and clean with a lint-free cloth prior to installation. Install inner bearing, then carefully push each seal half (Belleville washer and metal sealing ring) into the housing until it is fully seated. Check that the seal is not cocked and that the washers are seated evenly at the bottom of the housing bore. **NOTE: Improper seal installation can result in uneven face loads around the circumference of the seal faces, causing scoring or the sealing rings to separate and allow oil to leak.**
7. Use denatured alcohol and a lint-free wipe to clean seal faces. Ensuring seal faces are thoroughly cleaned and no fine particles of dust are on seal.
8. Reinstall hub onto spindle. **NOTE: Be sure seals are correctly installed without dislodging inner/outer bearings and metal face seals until seals make contact.**
9. Install outer bearing and flat washer. Then install lock nut and torque to 75-90 ft-lbs. Rotate each direction 10 revolutions. Back off nut and retorque to 45 ft-lbs. Do not rotate nut more than 30° to align for cotter pin. **NOTE: The hub MUST be held in place with slight pressure against face seal until lock nut is installed.**
10. Install cotter pin through nut and bend around nut.
11. Reinstall hub cover. Apply loctite 242 (blue) to hardware, tighten in star pattern. Torque hardware to 13-15 ft-lbs.
12. Refill oil. Refer to ["Drain and Replace Idler and Midroller Reservoirs" on page 3-9](#)

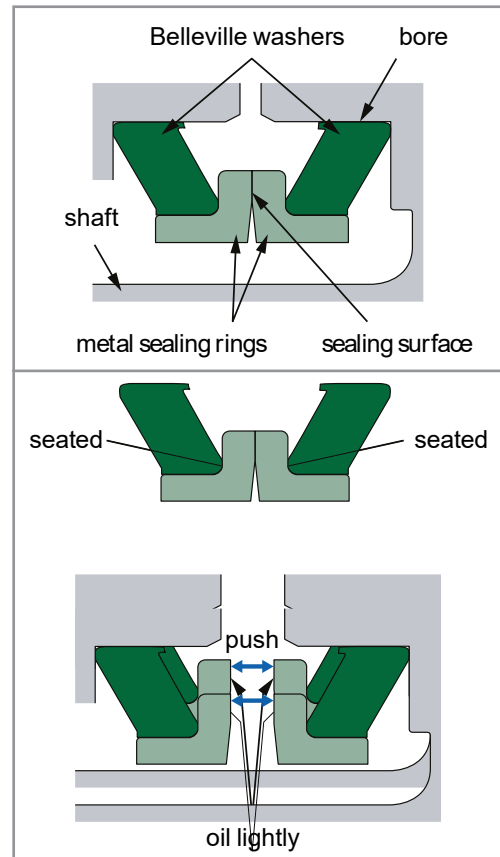

**TOP ROLLER WHEEL AND SEAL REMOVAL - CAMSO**

1. Remove track see "[Track Removal](#)" on page 3-18.



2. Remove five mounting bolts, remove top roller wheel, and then remove hub cover.

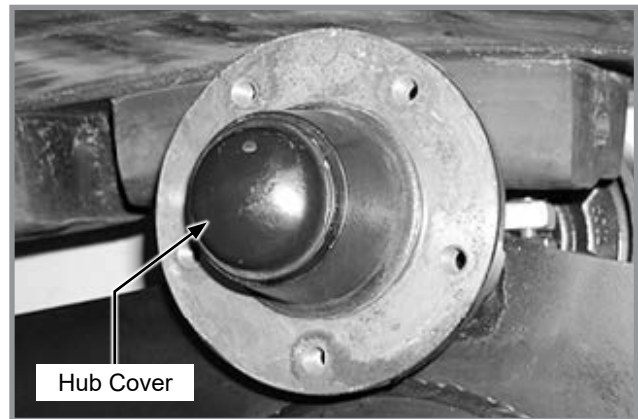
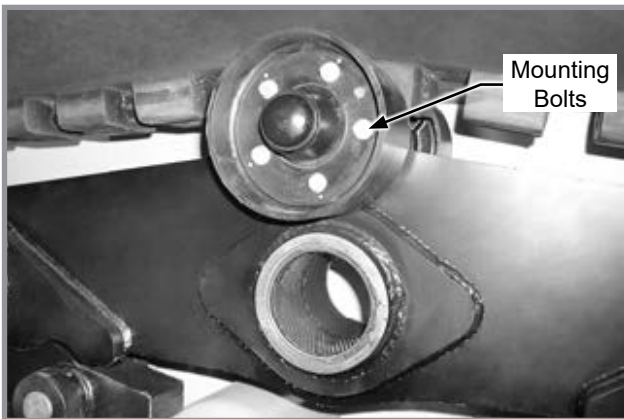

3. Bend lock washer tab out of lock nut, remove lock nut and lock washer.

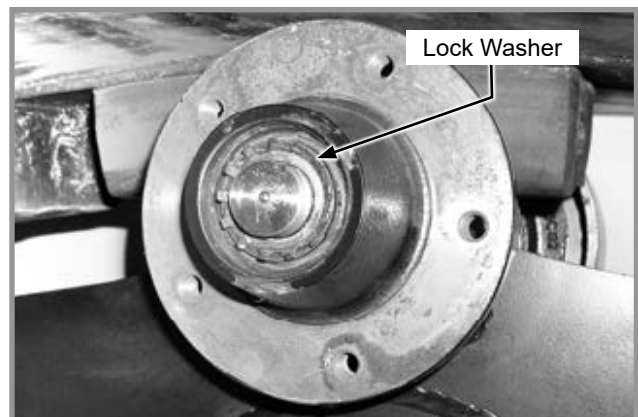
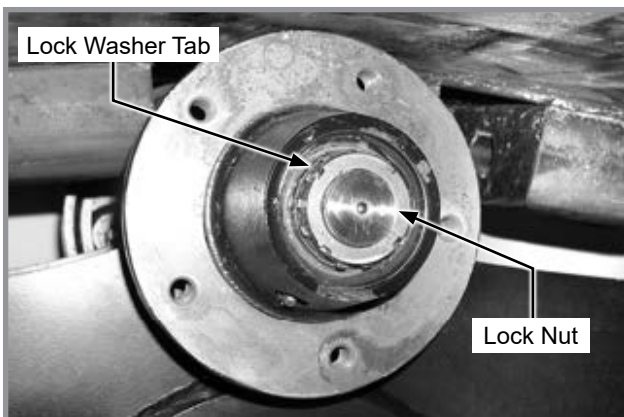

4. Remove thrust washer, remove outer bearing, and remove hub.

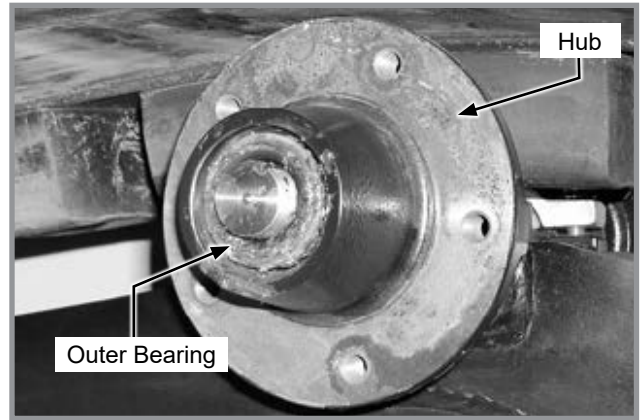
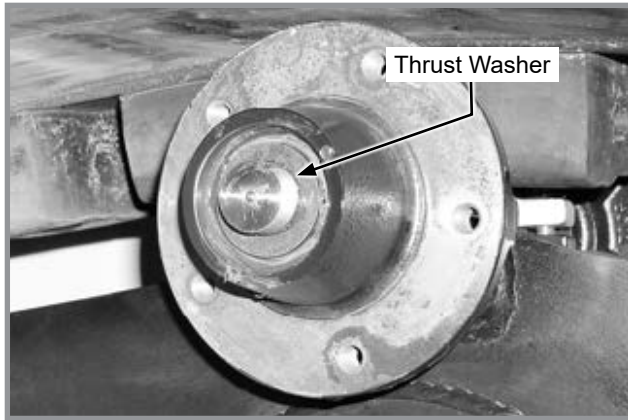

**This page intentionally blank.**

**TOP ROLLER WHEEL AND SEAL REMOVAL - TDS**

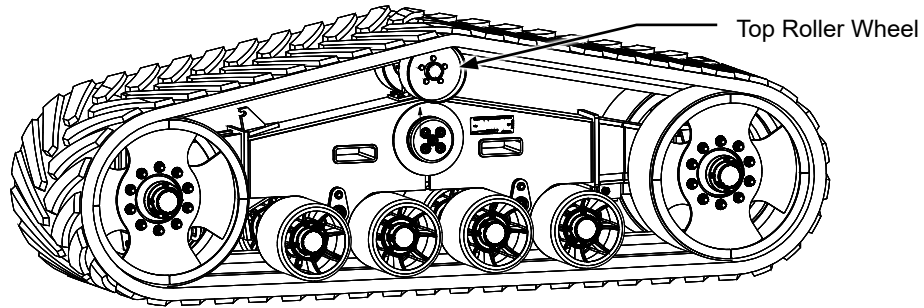

1. Detension belt. Then using a forklift, lift top of belt so it is not resting on top of roller.
2. Remove five mounting bolts, remove top roller wheel, and then remove hub cover.

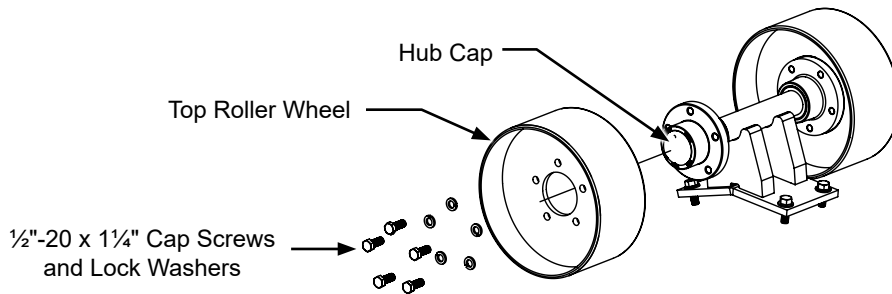

3. Bend lock washer tab out of lock nut, remove lock nut and lock washer.
4. Remove 1" washer, remove outer bearing, and remove hub.

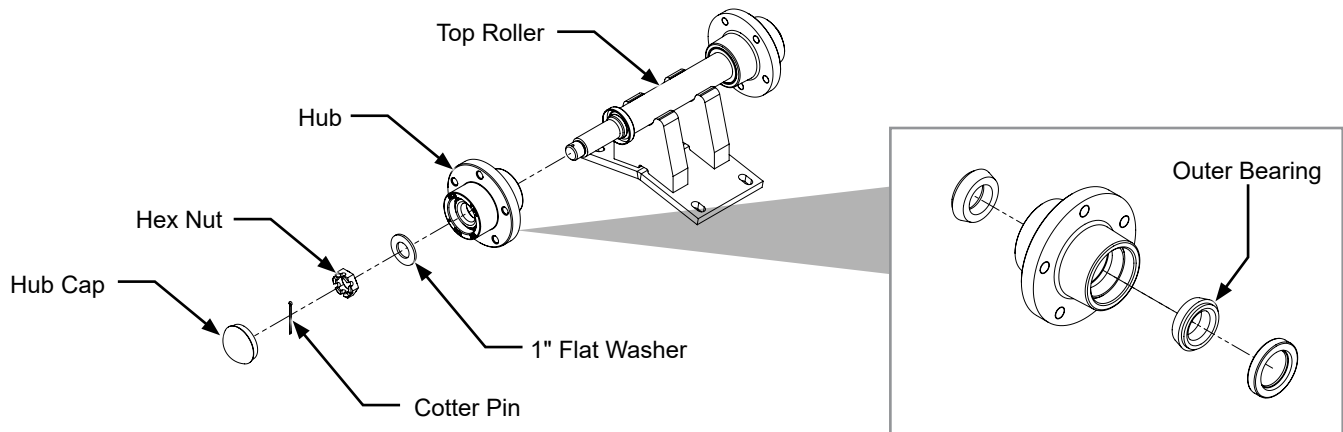

**MOUNTING BOLTS AND HARDWARE**



**WARNING**

Parts separation can result in death, serious injury, and damage to property and equipment. Check all hardware is tight before operating the grain cart the first time. Check all hardware again after first 50 hours of operation and beginning of each season. Check wheel nuts daily during first use and weekly afterward.





**NOTICE**

Over-tightening hardware can reduce its shock load capacity and cause equipment failure.

Hardware used on Kinze grain carts are Grade 5 (high strength) unless otherwise noted. Grade 5 cap screws are marked with three radial lines on the head. Hardware must be replaced with equal size, strength, and thread type.

**TORQUE VALUES CHART - PLATED HARDWARE**

Diameter	Grade 2 (No marks) 				Grade 5 (3 marks) 				Grade 8 (6 marks) 			
	Coarse		Fine		Coarse		Fine		Coarse		Fine	
	ft-lb	N-m	ft-lb	N-m	ft-lb	N-m	ft-lb	N-m	ft-lb	N-m	ft-lb	N-m
1/4"	50 in-lb	5	56 in-lb	6	76 in-lb	8	87 in-lb	9	9	12	10	13
5/16"	8	10	9	12	13	17	14	19	18	24	20	27
3/8"	15	20	17	23	23	31	26	35	33	44	37	50
7/16"	25	33	27	36	37	50	41	55	52	70	58	78
1/2"	35	47	40	54	57	77	64	86	80	108	90	122
9/16"	50	67	60	81	80	108	90	122	115	156	130	176
5/8"	70	95	80	108	110	149	125	169	160	217	180	244
3/4"	130	176	145	196	200	271	220	298	280	379	315	427
7/8"	125	169	140	189	320	433	350	474	450	610	500	678
1"	190	257	205	278	480	650	530	718	675	915	750	1016
1 1/8"	265	359	300	406	600	813	670	908	960	1301	1075	1457
1 1/4"	375	508	415	562	840	1138	930	1261	1360	1844	1500	2033
1 3/8"	490	664	560	759	1100	1491	1250	1694	1780	2413	2030	2752
1 1/2"	650	881	730	989	1450	1966	1650	2237	2307	3127	2670	3620

**NOTE:** Tighten pre-lubricated bolts and those with anti-seize to 70% of chart value.

**NOTE:** Prevailing torque hardware (i.e. top lock nuts, nylock nuts) come waxed and are thus treated as pre-lubricated.

**SPECIAL TORQUE VALUES**

Wheel nuts	350 ft-lb (474 N-m)
------------	---------------------

**Cylinder Rod Piston Retaining Nut Torque Chart**

	Non-Nylock Nut	Nylock Nut
1/2"-20	55-70 ft-lb (75-95 N-m)	45-55 ft-lb (61-75 N-m)
3/4"-16	115-125 ft-lb (156-169 N-m)	100-115 ft-lb (136-156 N-m)
7/8"-14	150-180 ft-lb (203-244 N-m)	130-150 ft-lb (176-203 N-m)
1"-14	275-330 ft-lb (373-447 N-m)	250-275 ft-lb (339-373 ft-lb)
1 1/8"-12	300-375 ft-lb (407-508 N-m)	275-300 ft-lb (373-407 N-m)
1 1/4"-12	300-375 ft-lb (407-508 N-m)	275-300 ft-lb (373-407 N-m)

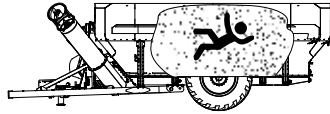
**DANGER**

Grain entrapment will result in death or serious injury. Never enter grain cart unless completely empty. Always use safety lines and have another person present when working on grain carts.

**DANGER**

Falling grain auger cart can crush and will cause death or serious injury. Never work around or under cart when raised without installing blocks to support cart. Use care when removing and installing components to prevent pulling or pushing cart off axles.

**WARNING**

Contacting rotating auger will cause death or serious injury. Never open or close cleanout door with auger operating.

Remove power source before working on equipment.

**WARNING**

Pressurized hydraulic fluid can penetrate body tissue and result in death, serious infection, or other injuries. Fluid injected under skin must be **IMMEDIATELY** removed by a surgeon familiar with this type of injury. Make sure connections are tight and hoses and fittings are not damaged before applying system pressure. Leaks can be invisible. Keep away from suspected leaks. Relieve pressure before searching for leaks or performing any system maintenance.

## VERTICAL AUGER COUNTER BALANCE VALVES



Counter balance valves prevent auger fold cylinder from extending or retracting without applied hydraulic pressure. If valve(s) fail to lock auger in position or fail to function properly, remove valve(s) from valve block and check for foreign material. Replace valve if defective.

## WHEEL SERVICING





**20 Bolt Hub Shown**

Clean threads with a wire brush and oil lightly to retard corrosion when removing and installing wheels.

Torque wheel nuts as specified in [“Mounting Bolts and Hardware” on page 3-38](#) and **retorque daily during first 3 days** of use and weekly thereafter.

**NOTE: Retorque all track system idler and midroller bolts daily during first 3 days of use and monthly thereafter. Torque bolts to 457 ft-lbs (620 N-m).**



**TIRE SERVICING**

 <b>WARNING</b>	<p><b>Explosive separation of rim and tire parts can cause death or serious injury. Over-inflation, rim and tire servicing, improper use of rims and tires, or worn or improperly maintained tires could result in a tire explosion.</b></p>
	

To prevent tire explosions:

- Maintain proper tire pressure. Inflating a tire above or below the recommended pressure can cause tire damage.
- Mount tires only by properly trained personnel using proper equipment.
- Replace tires with cuts or bubbles. Replace damaged rims. Replace missing lug bolts and nuts.
- Do not weld or heat wheel assembly. Heating increases tire pressure.

**INFLATION SPECIFICATIONS**

 <b>WARNING</b>	<p><b>Over-inflation of tires can result in explosive separation of rim and tire and cause death or serious injury. Different size rims are designed for different tire pressures. Inflate to correct pressure for specific rim size.</b></p>
	

Check tire pressure before each use.	Pressure
IF900/65 R32 CFO 191B (Diamond Tread) . . . . .	46 PSI (317 kPa)
IF900/60 R32 CFO 188B (Lug Tread) . . . . .	46 PSI (317 kPa)
VF1050/50R32 R1 (Lug Tread) . . . . .	46 PSI (317 kPa)

**DRIVELINE INSPECTION**

Inspect driveline **after first 20 loads, at beginning of each season, and after every 150 loads or annually thereafter.**

- Make a general inspection of driveline looking for loose hardware.
- Inspect all grease points for damage.
- Lubricate all grease fittings. See Lubrication section of this manual.
- Check gearbox oil level.
- Inspect bearings and seals in gearbox.
- Inspect PTO attaching hardware and safety shields.
- Repair or replace worn or damaged parts.

## UPPER VERTICAL AUGER REPLACEMENT

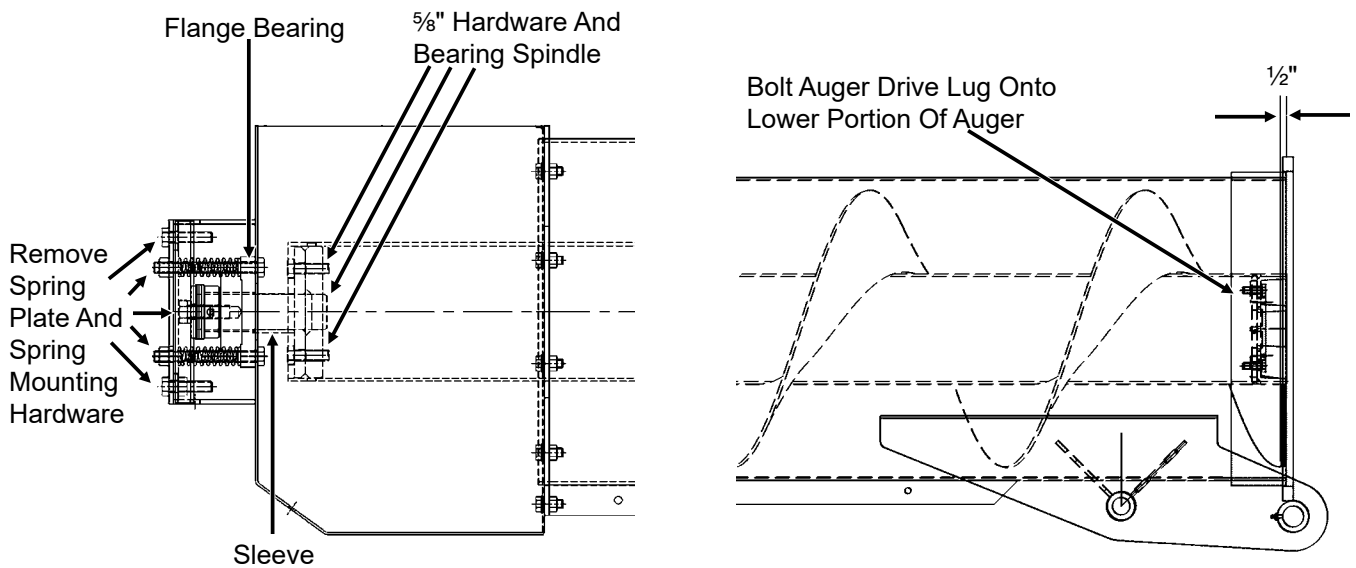

1. Position the vertical auger in a horizontal position as illustrated.
2. Remove  $\frac{3}{4}$ " hardware from center of bearing,  $\frac{5}{8}$ " spring plate hardware and  $\frac{5}{8}$ " spring mounting hardware.
3. Remove spring plate, flange bearing and sleeve.
4. Pull auger out of the bottom of the auger housing.
5. Remove  $\frac{5}{8}$ " hardware securing bearing spindle and remove bearing spindle.
6. Install bearing spindle onto replacement auger. Install replacement auger inside auger housing. Locate auger with  $\frac{1}{2}$ " (See Illustration) between bottom of hinge plate and end of auger assembly.
7. Reinstall sleeve, flange bearing and spring plate.

## LOWER VERTICAL AUGER REPLACEMENT



1. Position vertical auger in the storage/transport folded position.
2. Remove five  $\frac{1}{2}$ " x  $1\frac{1}{2}$ " hanger bearing bracket carriage bolts at upper end of lower vertical auger (two bolts visible in photo above). Carefully work hanger bearing bracket loose from auger housing.
3. Position strap around auger as shown above. Be sure strap is tight against auger center tube. Pull auger and hanger bearing assembly out of auger housing.
4. Remove  $\frac{3}{4}$ " x 5" cap screw at top of lower vertical auger and remove hanger bearing bracket components from auger.
5. Remove four  $\frac{5}{8}$ " x 2" cap screws that attach bullet spindle to top of lower vertical auger.
6. Install bullet spindle onto top of replacement auger aligning  $\frac{3}{8}$ " hole in auger with  $\frac{3}{8}$ " hole in bullet spindle.
7. Position hanger bearing bracket components onto top of replacement auger. Torque  $\frac{3}{4}$ " x 5" cap screw at top of lower auger to 200 ft. lbs.
8. Lower replacement auger into lower auger housing and onto lower drive lugs.
9. Position hanger bearing bracket with the split in the bracket in "up" position. Install four hanger bearing carriage bolts and nuts and tighten.

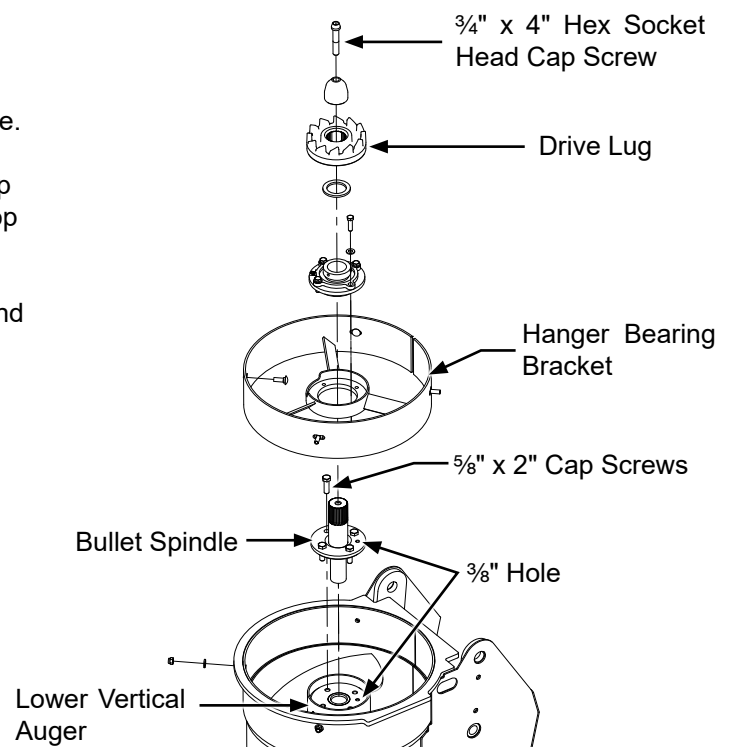

## WHEEL BEARING REPLACEMENT

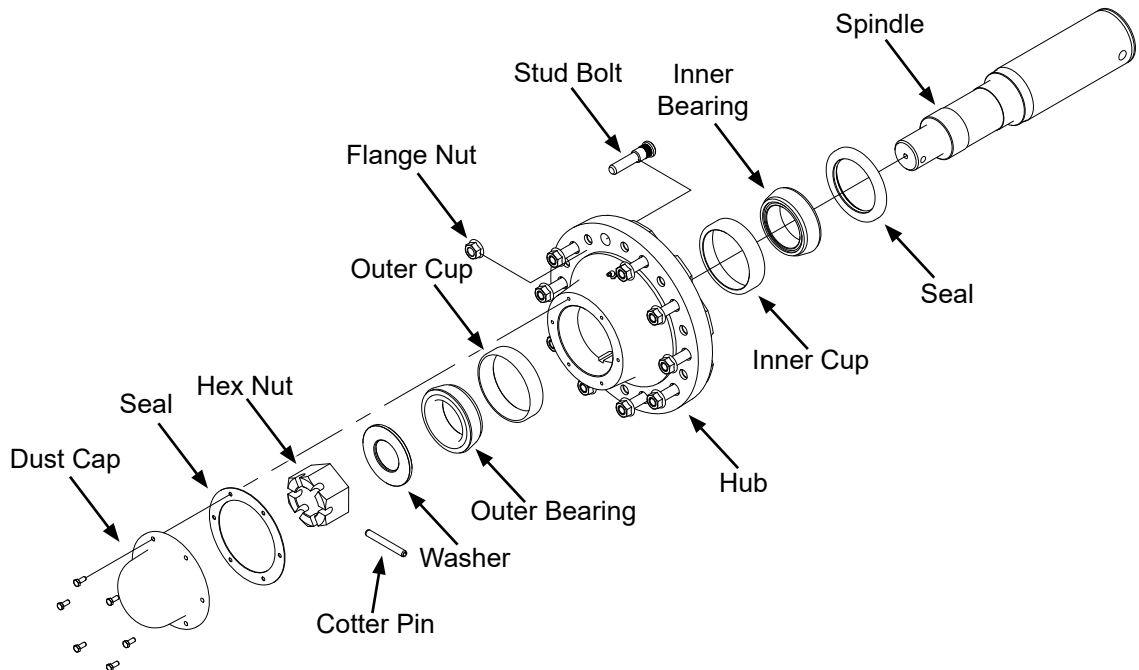

1. Raise tire clear of ground and remove wheel.
2. Remove dust cap attachment hardware and remove cap from wheel hub.
3. Remove cotter pin, axle nut and 2" washer.
4. Slide hub from axle spindle, using a hub puller if necessary.
5. Remove bearings and cups from hub and discard. Thoroughly clean and dry wheel hub.
6. Press in new bearing cups with thickest edges facing in.
7. Pack bearing with heavy duty wheel bearing grease, thoroughly forcing grease between roller cone and bearing cage. Also fill the space between the bearing cups in the hub with grease.
8. Place inner bearing in hub and press in new grease seal with lip pointing towards bearing.
9. Clean axle spindle and install hub.
10. Install outer bearing, 2" washer and slotted hex nut. Tighten slotted hex nut while rotating the hub until there is some drag. This ensures that all bearing surfaces are in contact. Back off slotted nut to nearest locking slot and install cotter pin. Check for endplay in bearings.
11. Fill dust cap half full of wheel bearing grease and install on hub with attachment bolts.
12. Install wheel. Refer to ["Wheel Servicing" on page 3-40](#) for procedure.

**NOTE: Wheel hubs on Kinze grain carts contain high strength ductile iron material. Replace hub with proper part.**

**PREPARATION FOR STORAGE****Hydraulic Hose Storage****7-pin Electrical Connector Storage**

Store machine in a dry sheltered area.

Store hydraulic hoses in slot on PTO cover.

Store 7-pin electrical connector in holder.

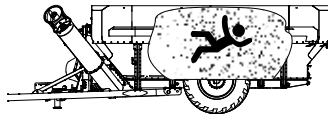

Entering the grain cart can result in death or serious injury.

- Never enter grain cart when there is an energy source attached to the cart.
- Flowing grain can trap and suffocate.

**PREPARATION FOR STORAGE (CONTINUED)**

	<p>Entering the grain cart can result in death or serious injury.</p> <ul style="list-style-type: none"> <li>• Never enter grain cart when there is an energy source attached to the cart.</li> <li>• Flowing grain can trap and suffocate.</li> </ul>
	
	<p>Contacting rotating auger will cause death or serious injury. Never open or close cleanout door with auger operating.</p> <p>Remove power source before working on equipment.</p>
	
	<p>Contact with rotating driveline will cause death or serious injury. Keep away at all times when operating.</p> <p>Never operate without all guards and equipment shields properly installed.</p>
	

Remove all trash that may be wrapped on shafts and remove dirt that can draw moisture.

Open auger cleanout door and clean out all accumulated grain and debris from auger chamber.

Wash machine inside and out.

After washing machine, leave cleanout door open ½" to allow for drainage.

Lubricate machine at all lubrication points.



If possible, remove weight from all tires, particularly if unit is stored outdoors.

Repaint any areas where paint has been removed. This is particularly important in the inside of grain tank. Rust in this area will shorten cart life and prevent grain from smoothly sliding to bottom of tank.

Inspect machine for parts in need of replacement and order during "off" season.

Coat exposed surface of all cylinder piston rods with grease or rust preventative spray.

**HYDRAULIC HOSE LIFE**

 <b>WARNING</b>	<b>Pressurized hydraulic fluid can penetrate body tissue and result in death, serious infection, or other injuries. Fluid injected under skin must be IMMEDIATELY removed by a surgeon familiar with this type of injury. Make sure connections are tight and hoses and fittings are not damaged before applying system pressure. Leaks can be invisible. Keep away from suspected leaks. Relieve pressure before searching for leaks or performing any system maintenance.</b>
	

Proper storage of hydraulic hoses can significantly increase the life of the hoses, for a period of three to five years. After this period, service life of hoses may decrease, depending on variables such as variances in rubber materials and storage environment. Refer to the guidelines below for best practices when storing.

- Store in a clean, cool and dry area
- Avoid direct sunlight or moisture
- Do not store near high power electrical equipment
- Avoid contact with corrosive chemicals
- Avoid ultraviolet light
- Avoid areas with obvious signs of insects or rodents

Unusually long periods of storage or poor storage environment may lead to performance issues or premature failure. Always inspect all hoses prior to use for extensive wear, cuts, or holes. If such flaws are identified, replace immediately to avoid potential failure, property damage or bodily injury.

HYDRAULIC CONTROL SCHEMATIC - MANUAL

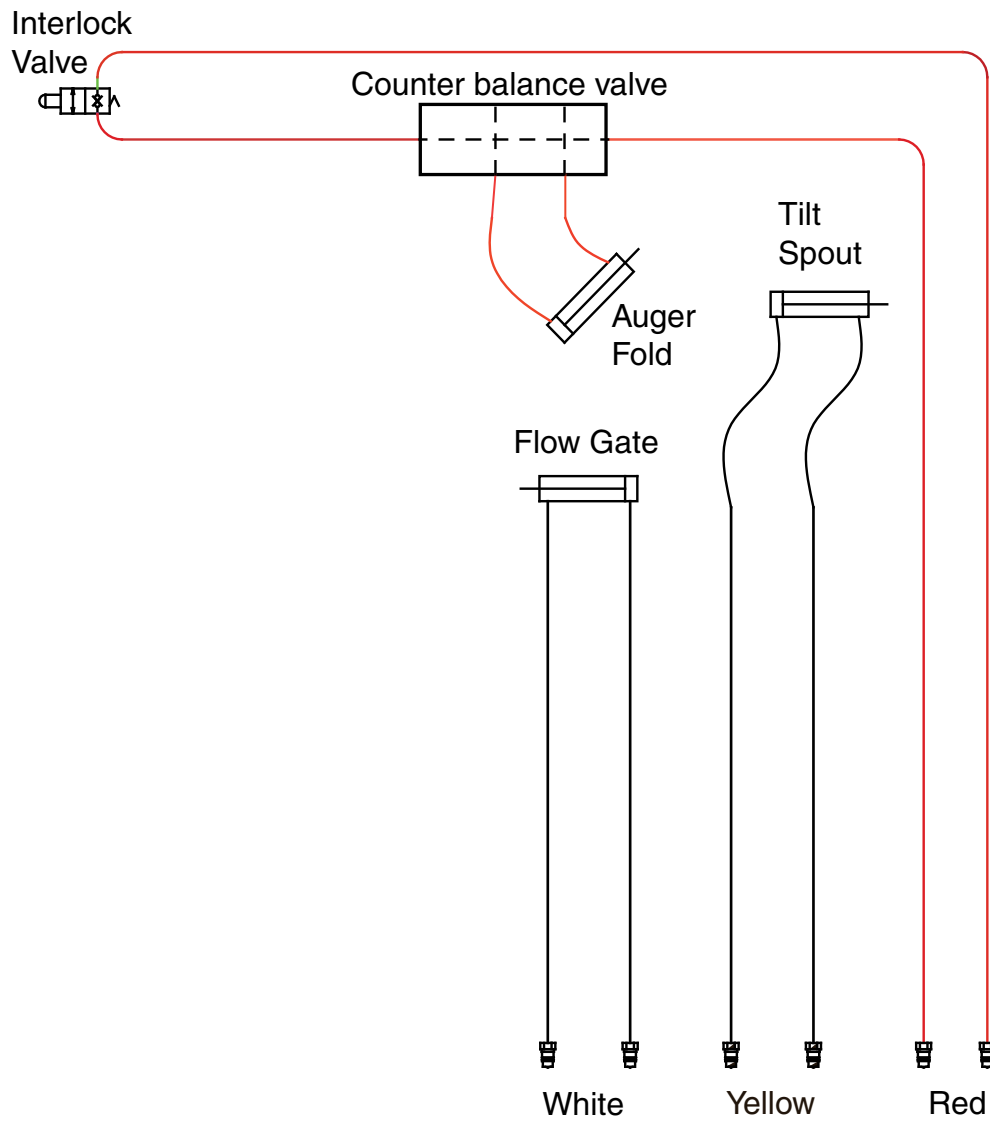

**WIRING DIAGRAM**



Additional auxiliary work lights are available from Kinze Repair Parts which may be wired into existing auxiliary light wires in the harness. The vertical auger work light and tub light is wired into the black terminal connector.

Grain cart safety/warning lights are the LED type and meet ASAE standards. Check with tractor manufacturer for correct wiring harness to be wired into lights on your tractor.

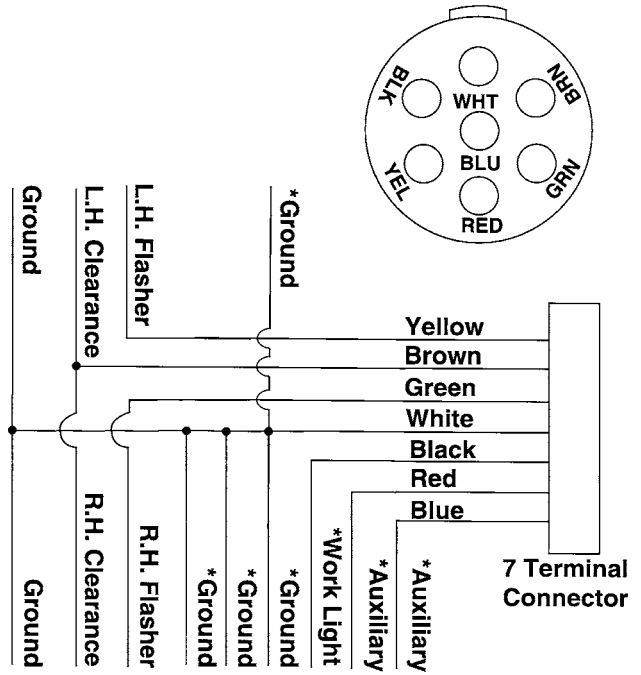

ELECTRONIC SCHEMATIC

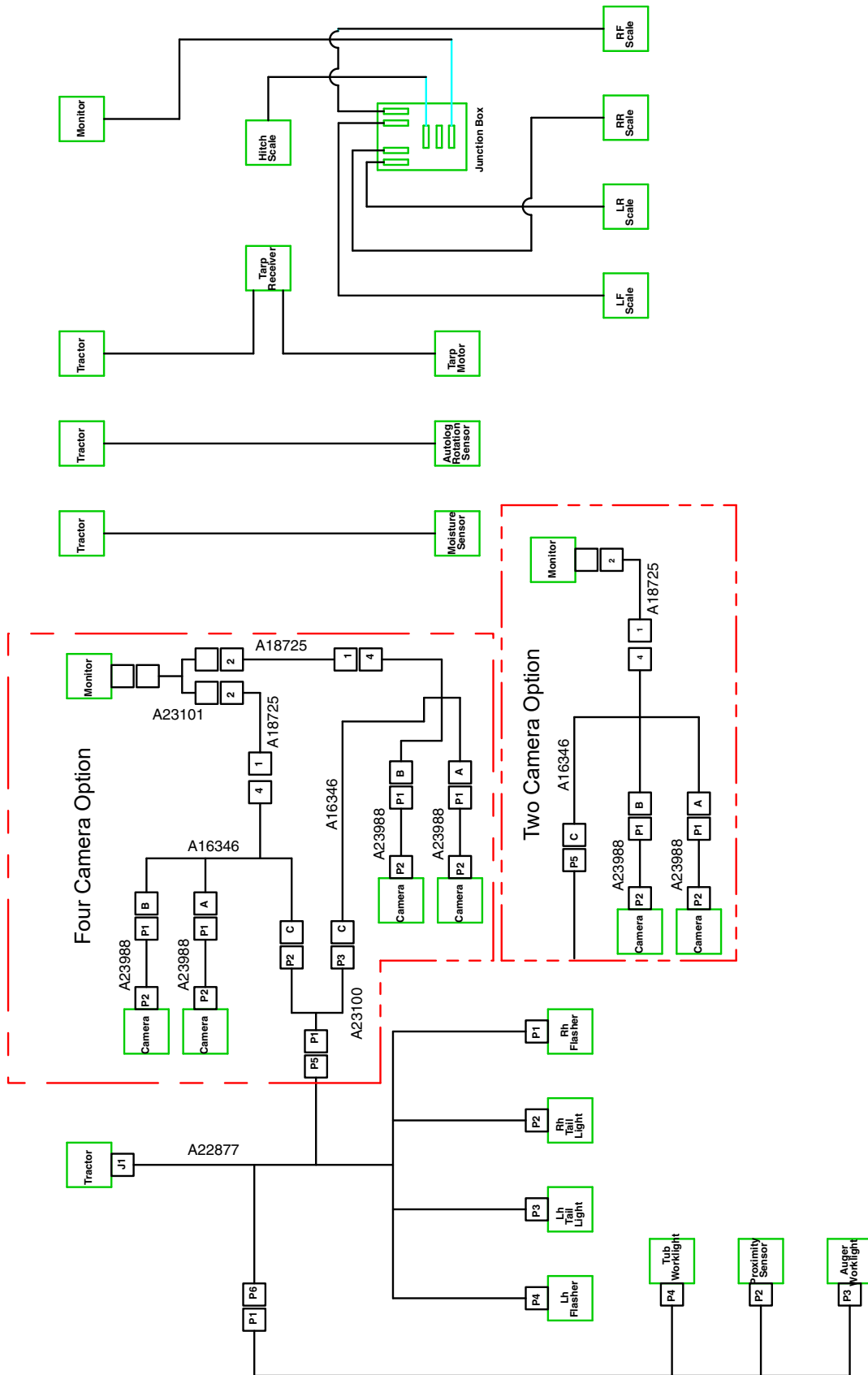

MOISTURE SENSOR HARNESS ROUTING

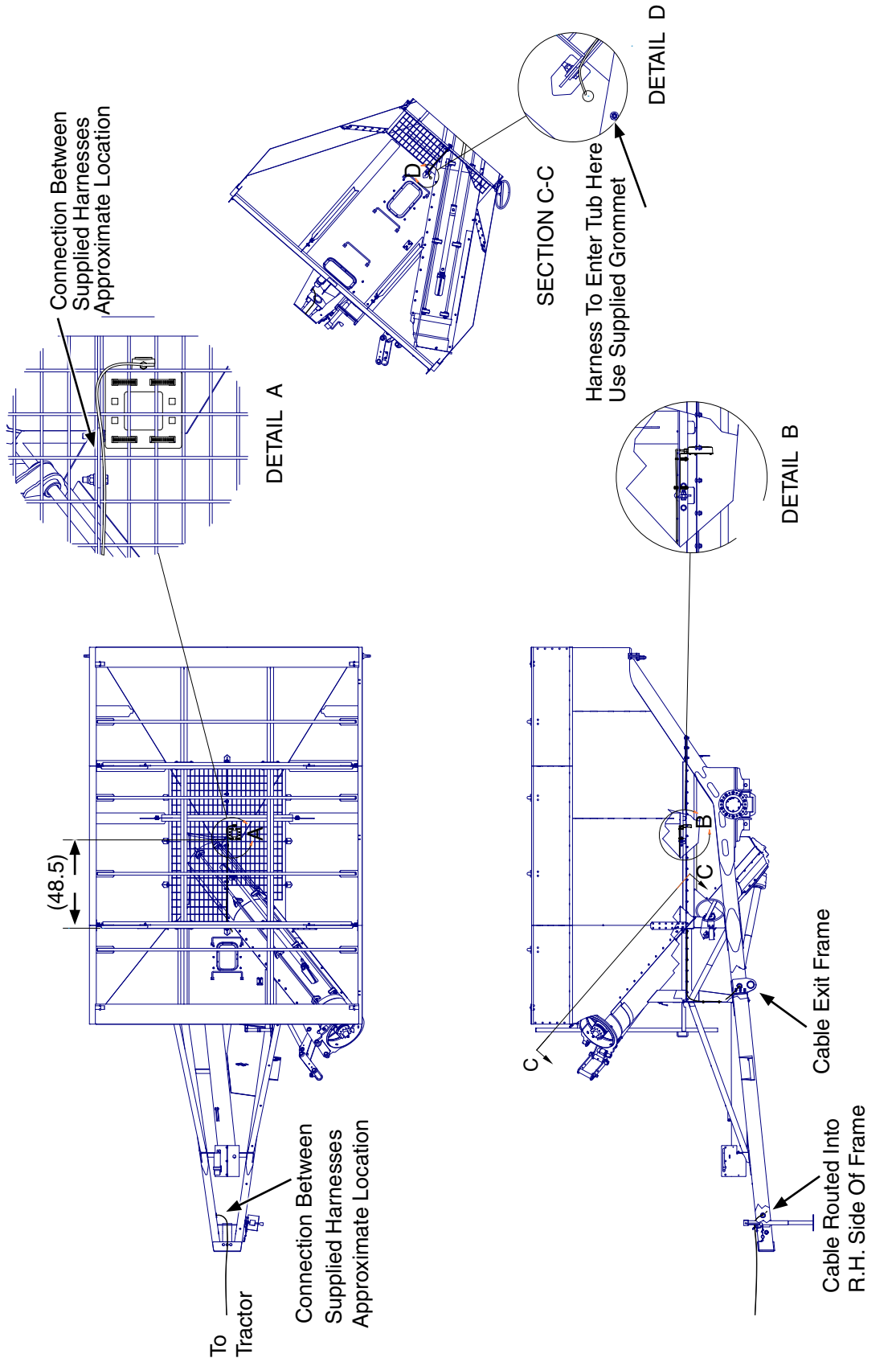

**AUTOLOG SENSOR HARNESS ROUTING**

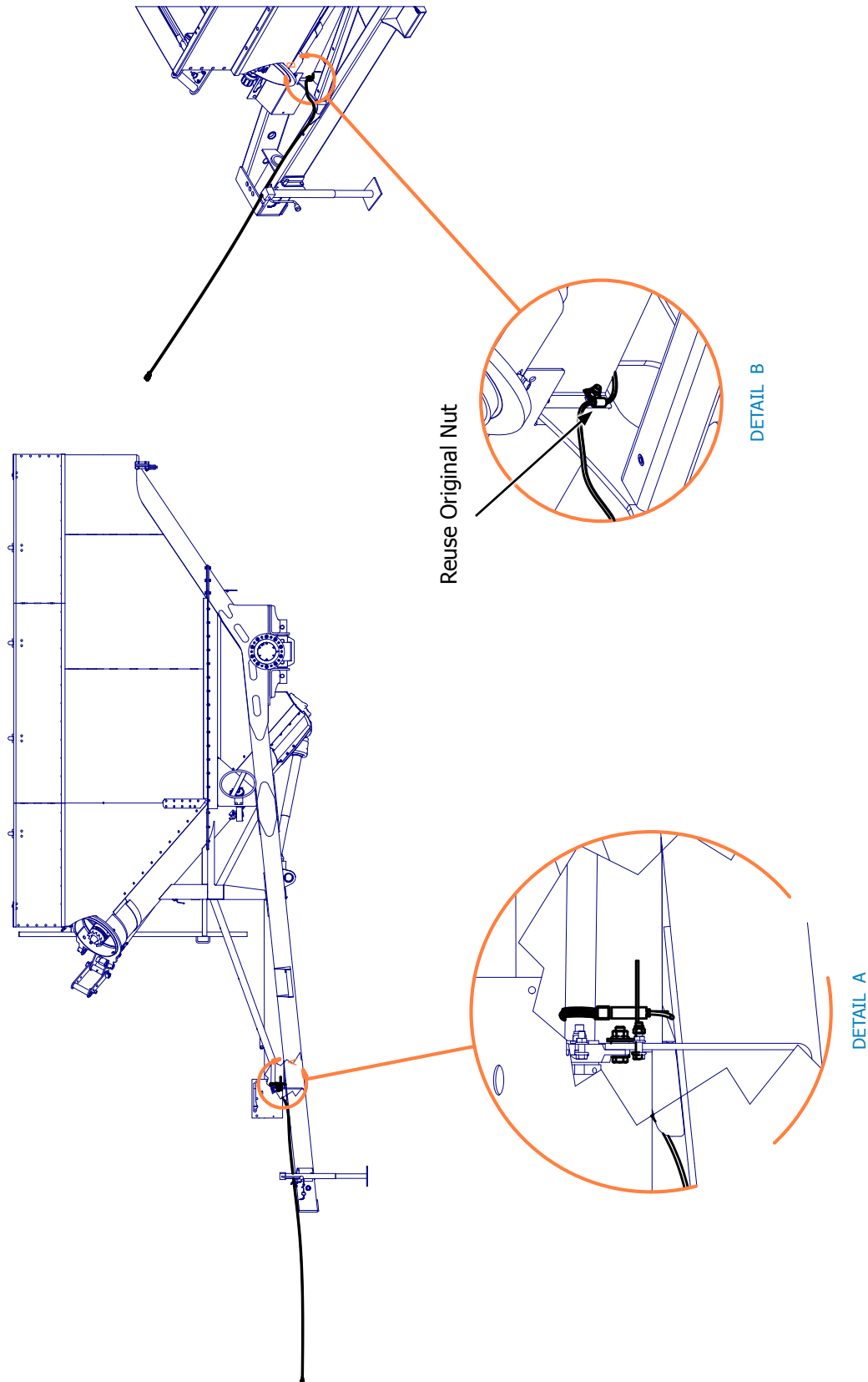

## ELECTRONIC SCALE

The major elements of the electronic scale are the indicator, four 30,000 lb (13607 kg) rated weigh beams at the axle assembly (applicable to track and flotation type carts) and 3<sup>3</sup>/<sub>4</sub>" hitch weigh beam, the junction box (j-box) and the battery power cable.

For additional information see "Electronic Scale Troubleshooting" for step-by-step procedures for troubleshooting failures that may be encountered with the electronic scale.

